

# Pimp My EV Rivian Running Boards

## User Manual



*Pimp My EV* 

**PIMPMYEV.COM**

# Important Information

1. **WARNING:** Read this document before using the EVBASE Rivian Running Boards.
2. This adapter is intended only to be used with R1T vehicles. Do not use it for any other purpose.
3. The installation instructions may be slightly different from the actual operation. If there is any difference, please contact us or according to the actual situation.
4. Please make sure the brackets are installed correctly in each direction.  
Contact EVBASE Customer Support for any repairs at [service@evbase.com](mailto:service@evbase.com)
5. Do not clean with detergent or cleaning solvents.
6. Do not use if it is damaged or corroded in any way.  
Inspect before each use.
7. Please tighten the screws of each part to make the installation firm.

# Product parameter

|               |                              |
|---------------|------------------------------|
| Load-bearing  | 550lb(250Kg)                 |
| Size          | 82.67*6.69 inch              |
| Packing List  | 2 pedals 6 brackets          |
| Installation  | Non-destructive installation |
| Material      | High-quality Carbon Steel    |
| Design style  | Original Car Style           |
| Certification | CE, FCC                      |

## PARTS LIST:

| No. | Name                                    | Qty | No.  | Name                                  | Qty |
|-----|---|-----|------|---------------------------------------|-----|
| (1) | Driver/Left Sidebar                     | 1   | (8)  | Passenger/Right Rear Mounting Bracket | 1   |
| (2) | Passenger/Right Sidebar                 | 1   | (9)  | M8 x 30mm Hex Head Bolts              | 12  |
| (3) | Driver/Left Front Mounting Bracket      | 1   | (10) | 8mm Flat Washers                      | 12  |
| (4) | Passenger/Right Front Mounting Bracket  | 1   | (11) | 8mm Lock Washers                      | 12  |
| (5) | Driver/Left Middle Mounting Bracket     | 1   |      |                                       |     |
| (6) | Passenger/Right Middle Mounting Bracket | 1   |      |                                       |     |
| (7) | Driver/Left Rear Mounting Bracket       | 1   |      |                                       |     |

# Installation Steps

1. Take out all parts from the box and verify that all parts are complete.

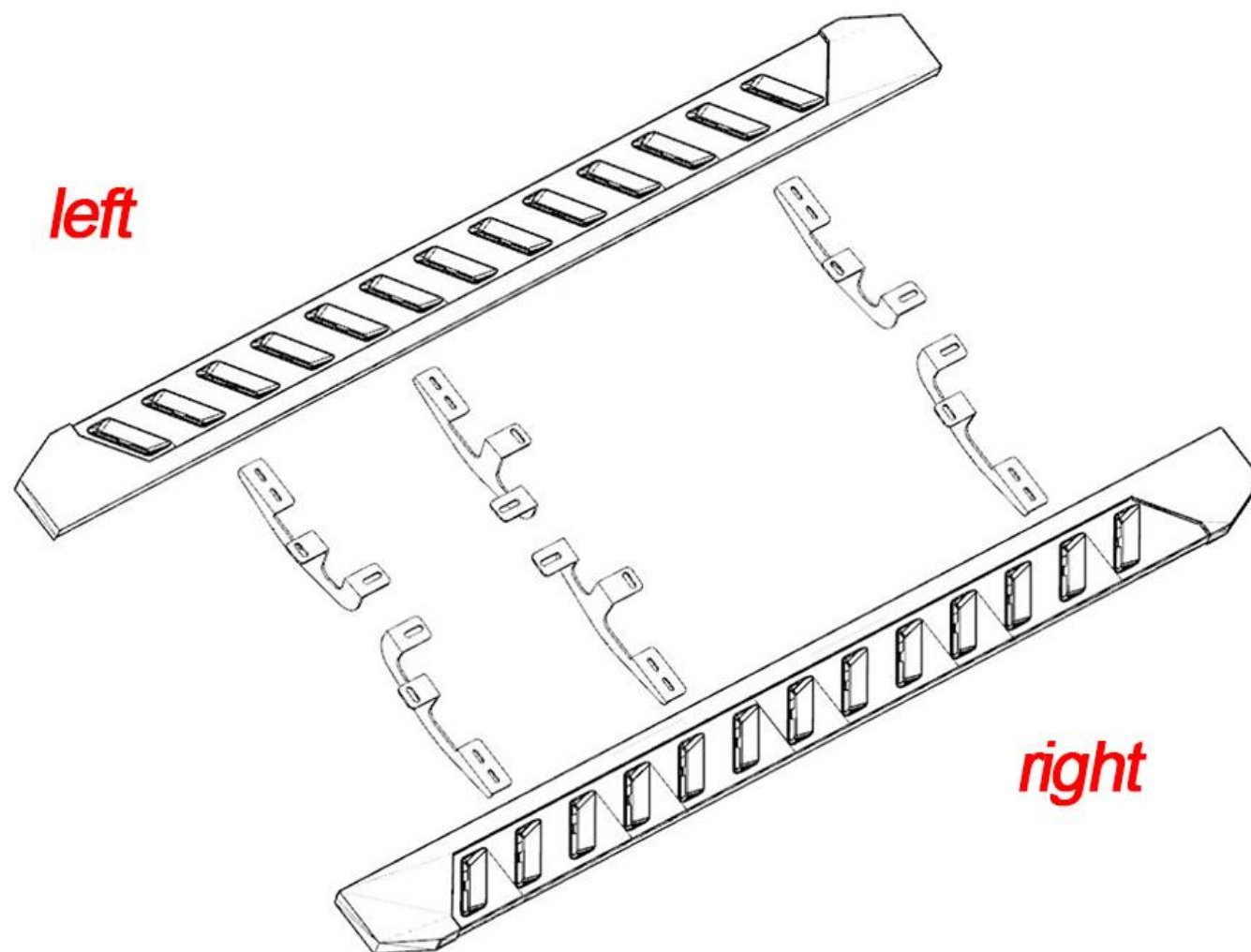

2. Use a flat screw to remove the plastic panels on the R1T bottom and and then remove the nuts and screws on the bottom of the side skir.

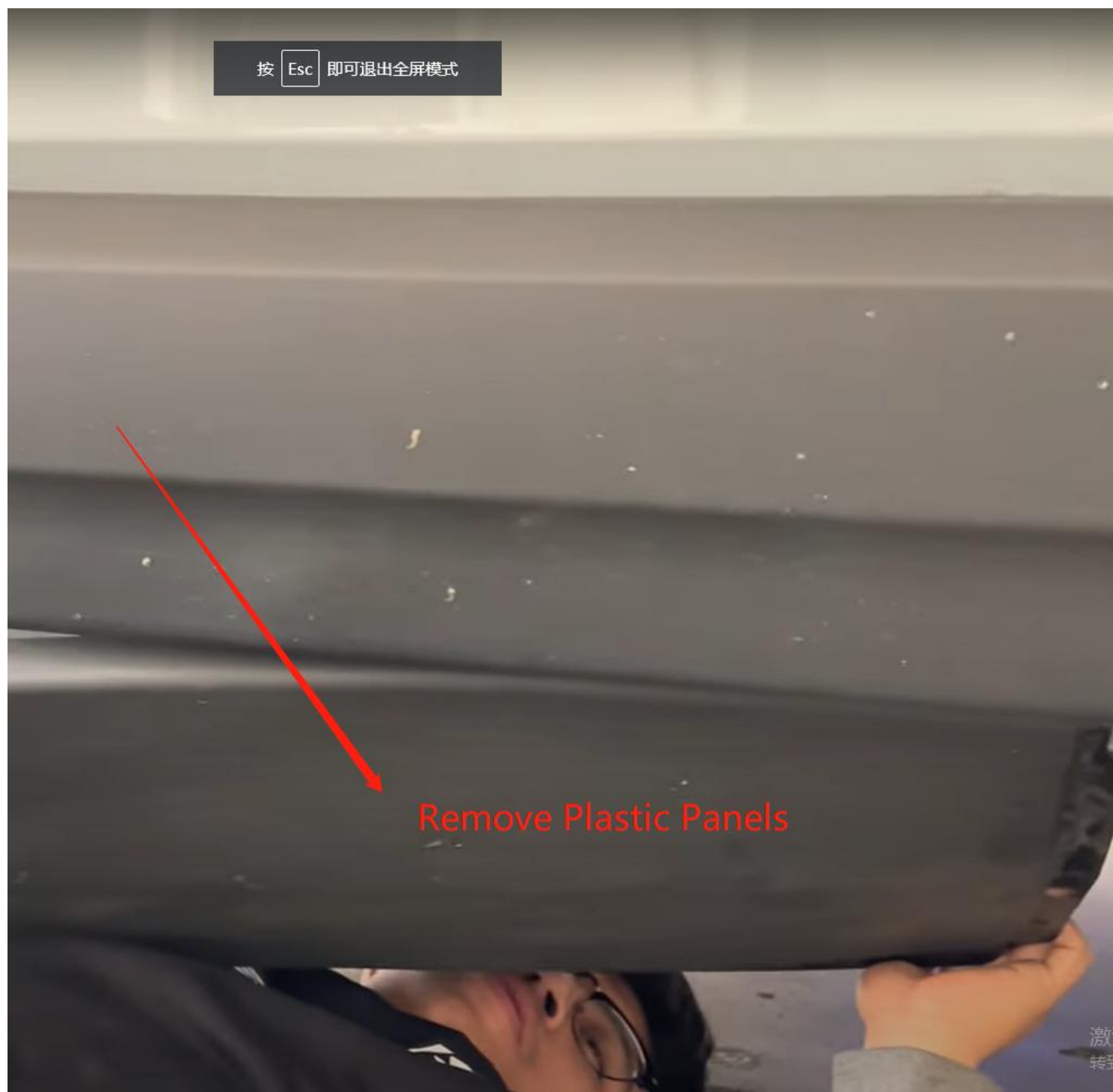

# Installation Steps

3. Starting on the driver side front of the vehicle, Partially attach driver/front Mounting Bracket to vehicle using our M10 screw, And reinstall the original car screws and nuts.

## Driver Side Installation Pictured

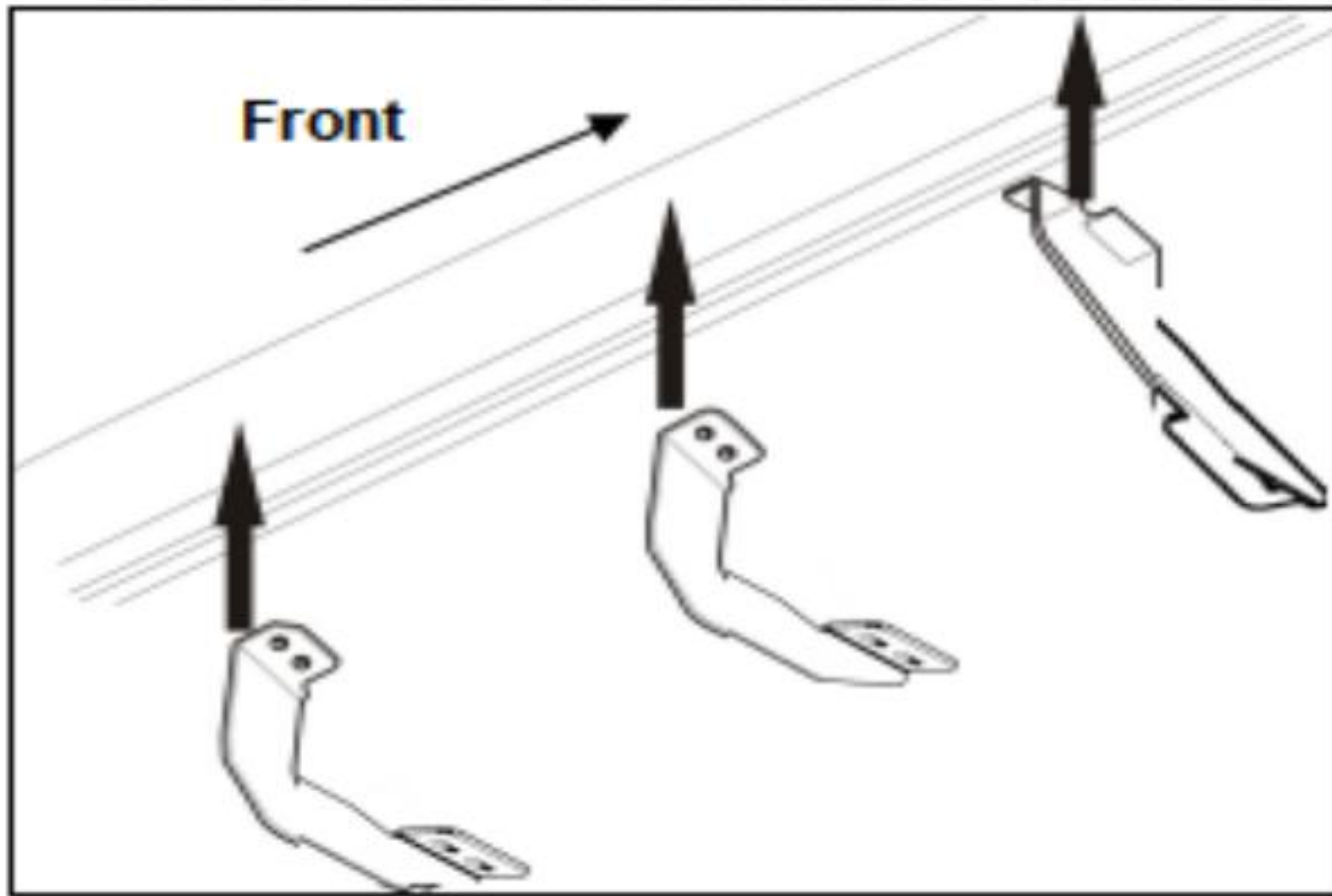

## Driver Side Front Bracket

### Center & Rear Bracket

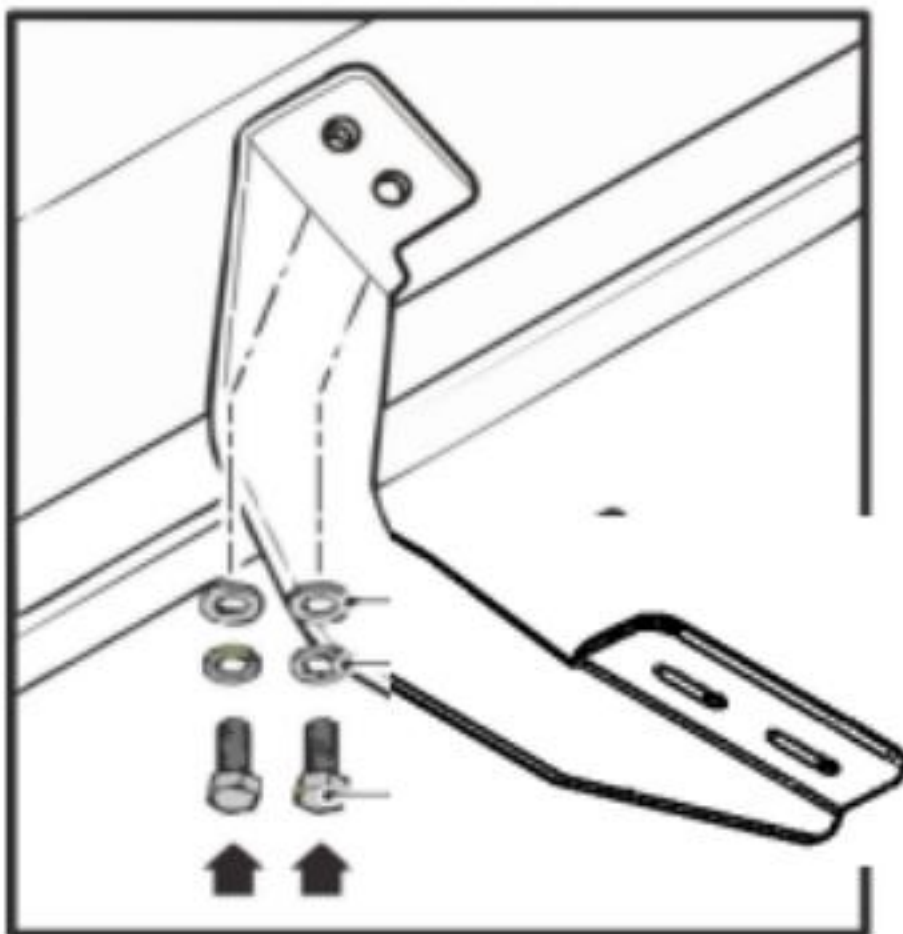

### Front Bracket

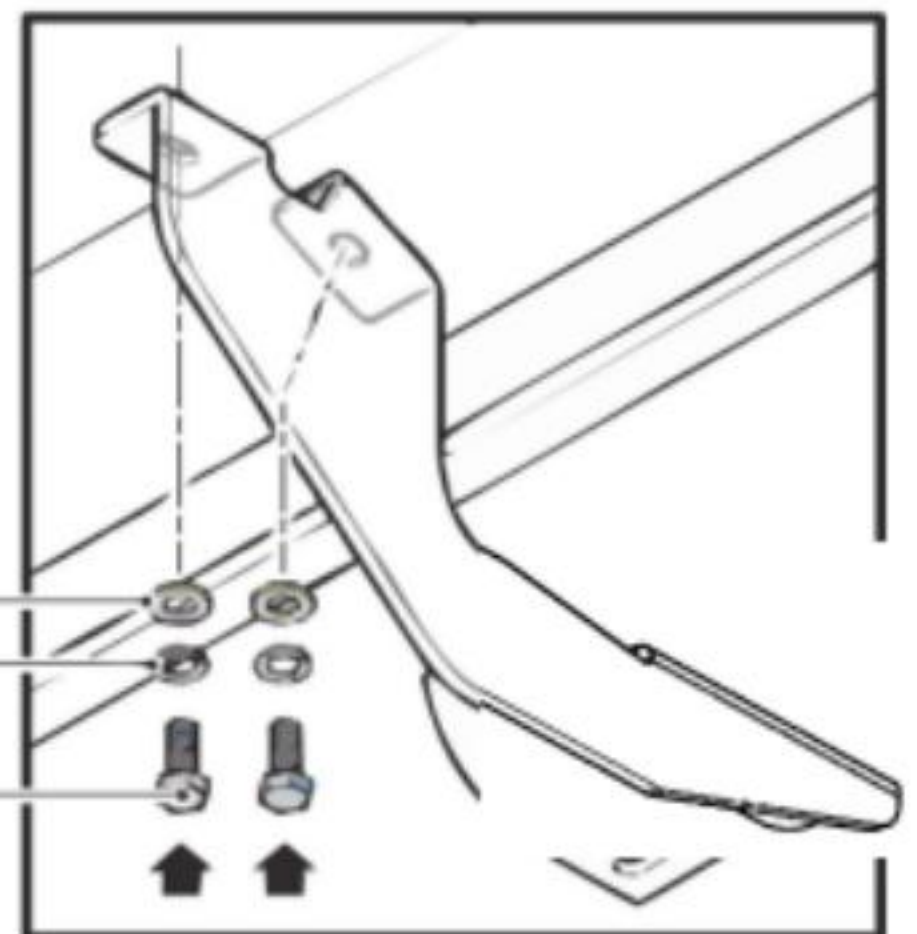

- M8 FLAT WASHER
- M8 LOCK WASHER
- M8\*30MM
- HEX HEAD BOLT

# Installation Steps

Installation diagram for Reinstall the original car screws and our screws.

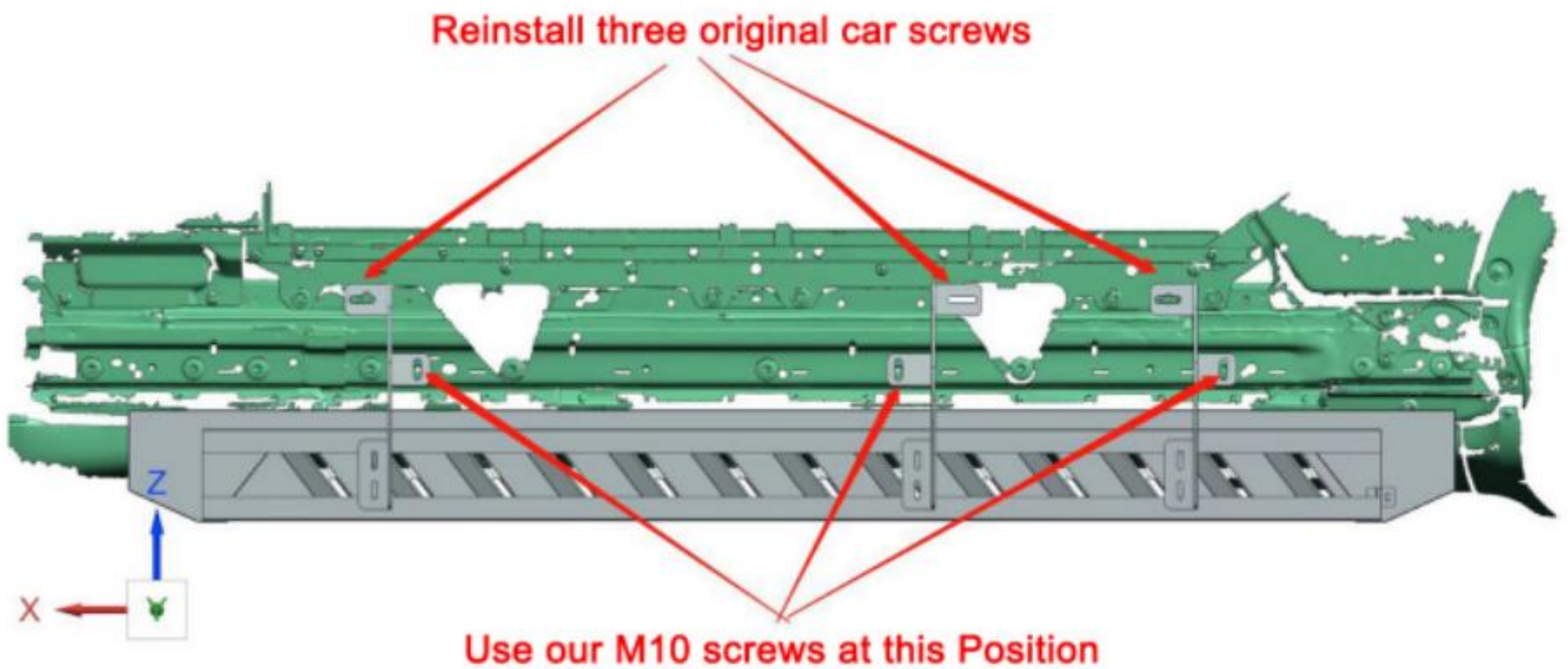

## Driver Side Front Bracket

### Center & Rear Bracket

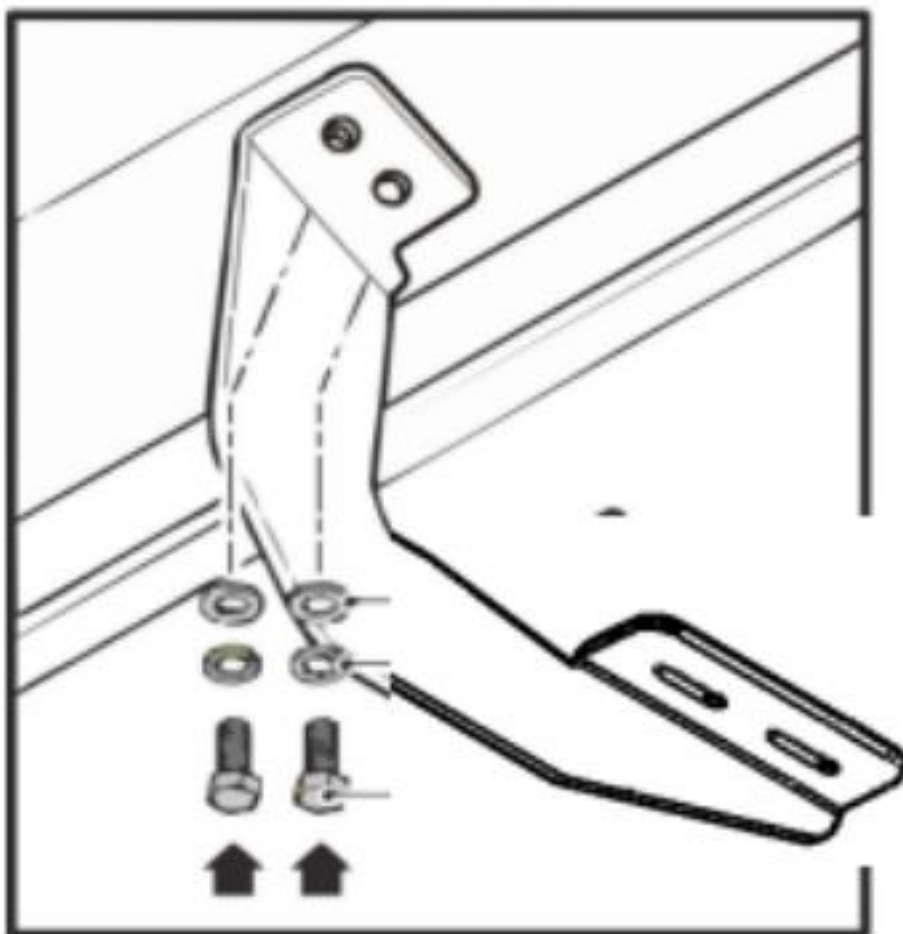

### Front Bracket

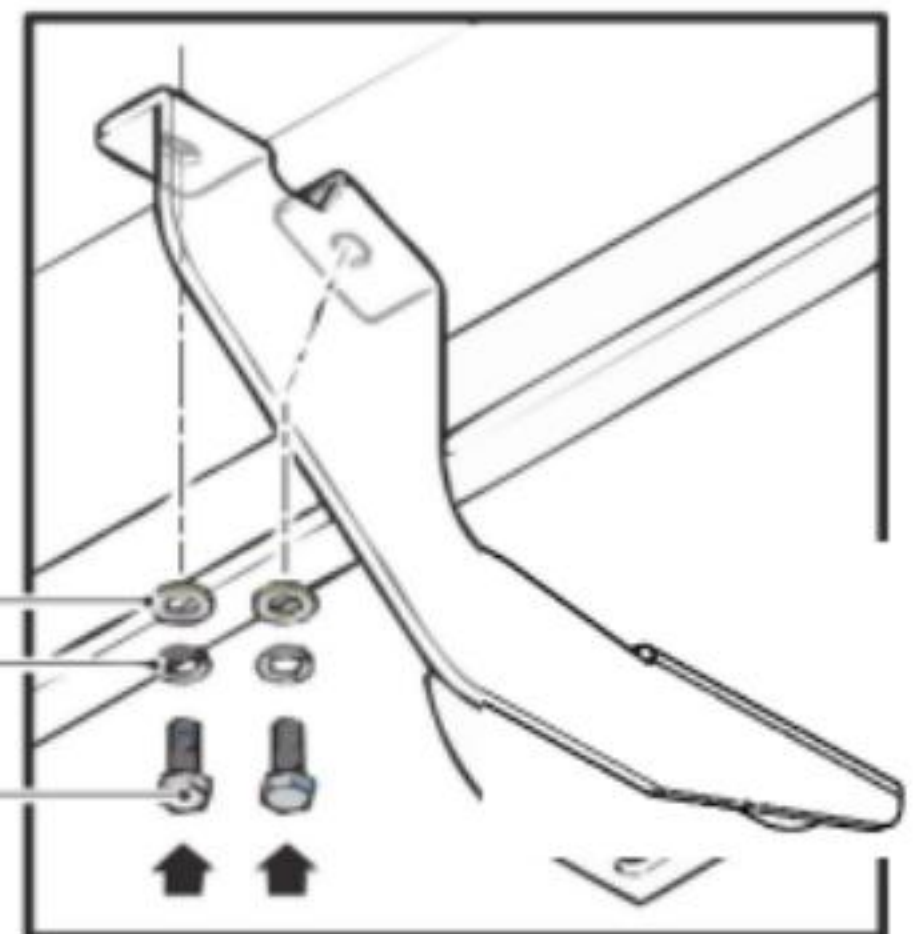

- M8 FLAT WASHER
- M8 LOCK WASHER
- M8\*30MM
- HEX HEAD BOLT

# Installation Steps

4. Repeat the above step for middle and Rear Mounting Brackets. Install three brackets on each side of the car. Install the corresponding bracket according to the serial number in the packing list.

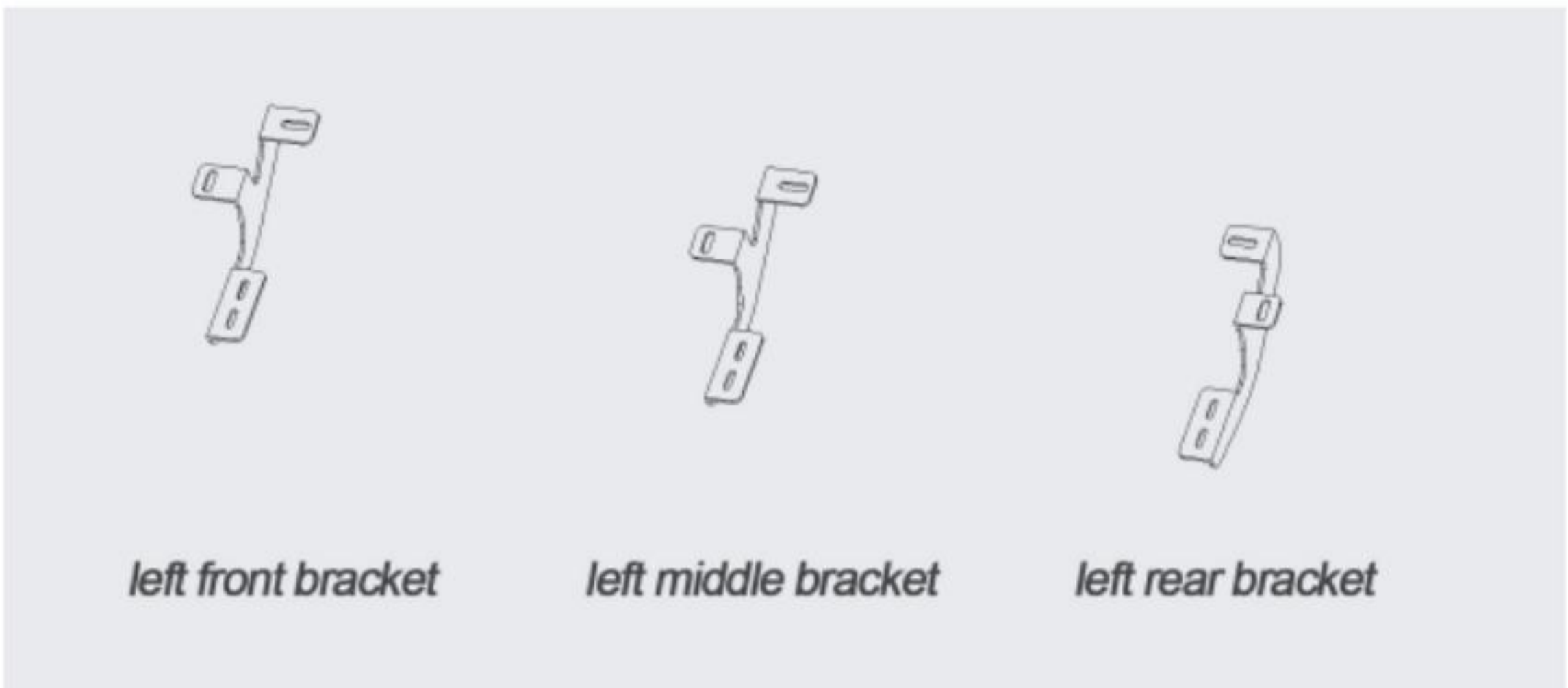
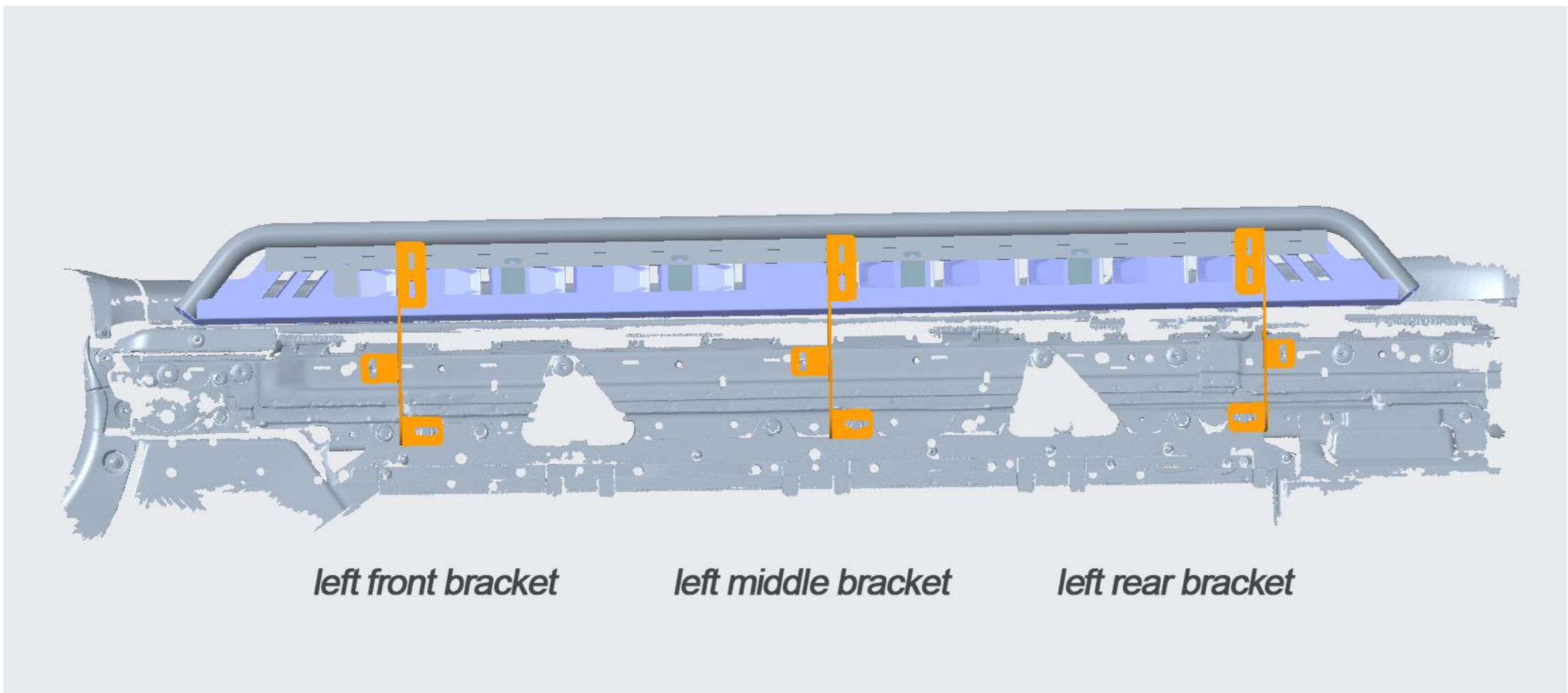

# Installation Steps

5. Cut off the extra plastic panels according to the following diagram.

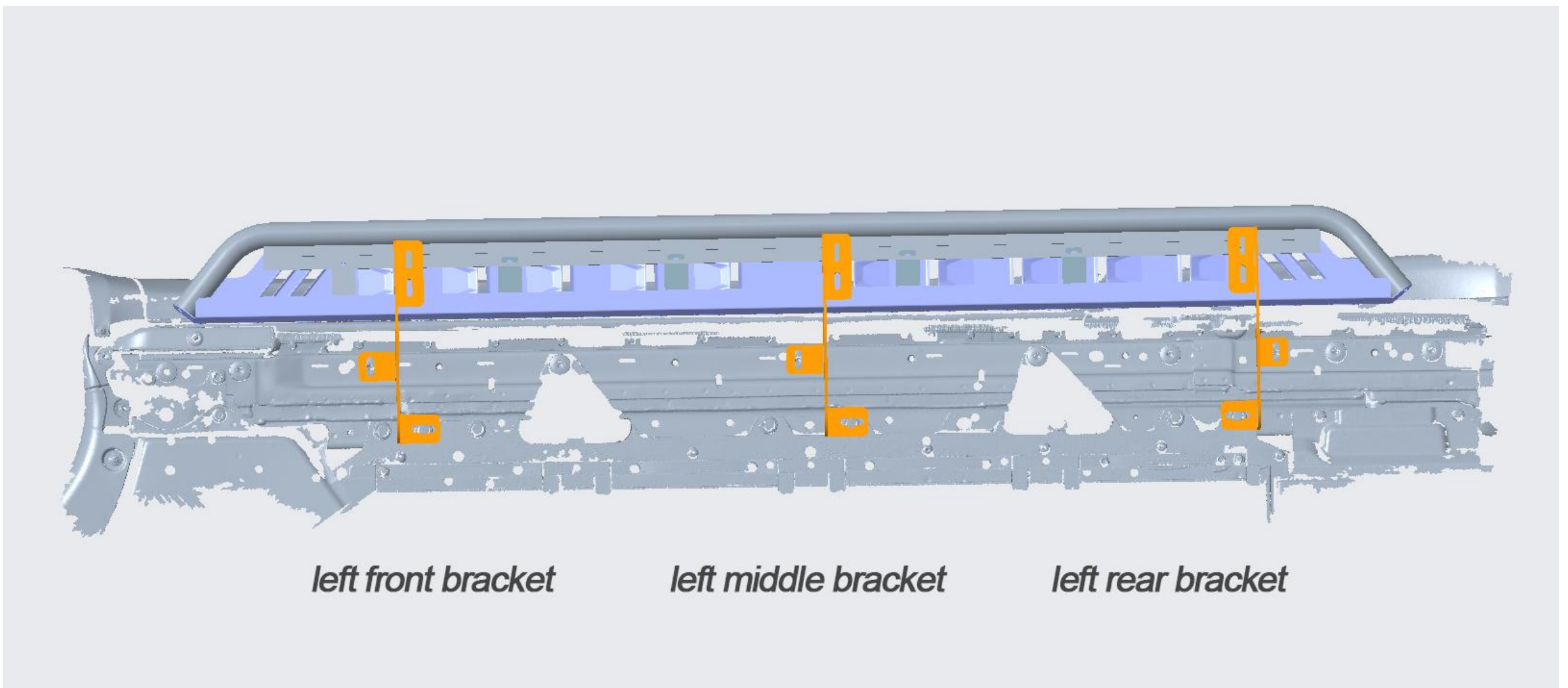
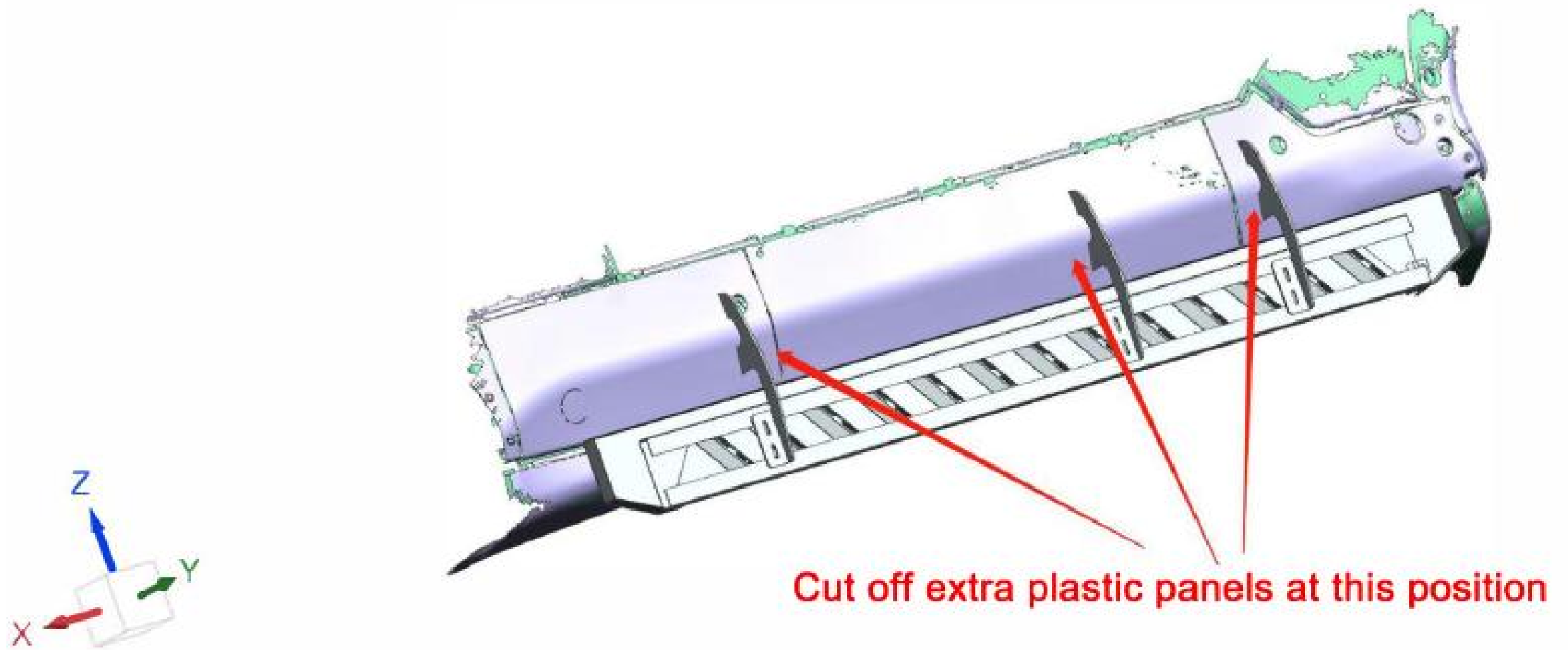



# Installation Steps

6. Install the left and right Running Boards with our M8 screws and nuts to fix them. Tighten the screws of each part, Reinstall plastic plate on the bottom complete the installation



## Installation Steps

1. Remove the left and right side bottom guards at the pedal installation position.
2. Find the corresponding bracket installation position and install the bracket on the car.
3. Cut off the part where the bottom guard plate interferes with the bracket and install the bottom guard plate.
4. Install the pedal to the bracket just installed, and the whole pedal is installed.

## IMPORTANT NOTE(Maintainance)

**To protect your investment,** Do not use any type of polish or wax that may contain abrasives that could damage the finish.

**For R1T Running board:** Aluminum polish may be used to polish small scratches and scuffs on the finish. Mild soap may be used also to clean the Sidebar.

**For finishes:** Mild soap may be used to clean the Sidebar.

# **WARRANTY and SUPPORT**

**One year manufacturers warranty on this product**

## **GET MORE SUPPORT**

**For all support queries, please email us on [orders@pimpmyev.com](mailto:orders@pimpmyev.com)**