

# Mastering Your **BERNINA®/bernette®** Sewing Machine

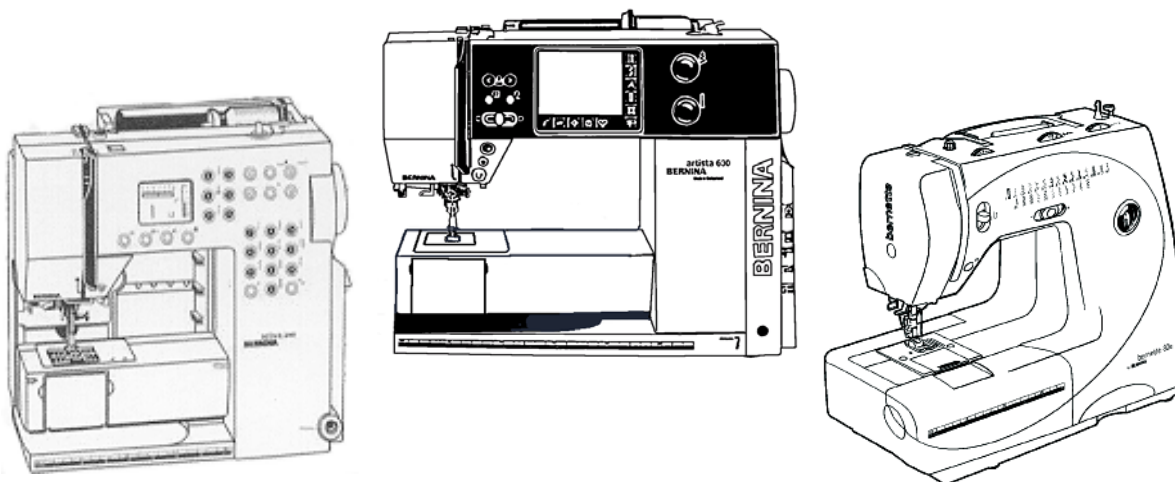

## *Owner's Workbook*

# Table of Contents

<b>Class 1 - General Information .....</b>	<b>3</b>
Introduction .....	4
Meet Your Feet .....	5
Sewing Machine Needles .....	6
Thread .....	8
Stabilizers & Interfacings .....	10
Samples .....	12
Product Reference List .....	30
<b>Class 2 - Practical Stitching .....</b>	<b>31</b>
Seam Samples .....	32
Hem and Edging Samples .....	40
Product Reference List .....	52
<b>Class 3 - More Practical Stitching .....</b>	<b>53</b>
Elastic Samples .....	54
Buttonhole & Eyelet Types & Uses .....	58
Buttonhole Feet .....	59
Button & Buttonhole Samples .....	60
Zipper Samples .....	70
Darning Sample .....	74
Product Reference List .....	76
<b>Class 4 - Decorative Techniques .....</b>	<b>77</b>
Gathering Samples .....	78
Specialty Needle Samples .....	86
Product Reference List .....	94
<b>Class 5 - More Decorative Techniques .....</b>	<b>95</b>
Decorative Technique Samples .....	96
Patchwork/Quilting/BSR/Applique Samplers .....	108
Surface Embellishment Sampler .....	124
Product Reference List .....	128
<b>Class 6 - Stitch Manipulations .....</b>	<b>129</b>
Memory - Basic Information .....	130
Function Sampler .....	132
Memory Samples .....	144
Setup Program .....	162
Tutorial .....	165
Creative Consultant .....	166
Product Reference List .....	168
<b>Class 7 - Directional Stitching .....</b>	<b>169</b>
Directional Stitching Samples .....	170
Product Reference List .....	188

# Class 1

## General Information

### Class Overview

#### Machine Overview

Parts of the machine  
Setting up the machine  
Getting ready to sew  
    Winding a bobbin  
    Threading the upper thread  
    Using the needle threader

#### Presser Feet & Accessories

BERNINA's philosophy - use correct tools  
Specific feet for each machine  
Attaching the presser feet  
Overview of additional feet  
Stitch Plates  
Feed Dog

#### Stitch Access

How to find the stitches on your machine  
Making the settings for each stitch

#### Tension

Adjusting tension  
Stitch formation

#### Needle Stop Adjustment

Foot control  
Needle Stop Up/Down function  
Correct use of handwheel

#### Sewing Machine Needles

Types of needles  
Sizes of needles  
Parts of needle  
Matching needle and thread

#### Sewing Thread

Good quality vs. poor quality  
Fibers and weight  
Thread storage ideas

#### Stabilizers & Interfacing

Difference between the two  
Different types and applications  
Sewing sprays

#### Samples

- 1 Straight Stitch/Seaming
- 2 Needle Positions
- 3 Securing Stitches
- 4 Stitching Corners
- 5 Zigzag/Oversewing Edges
- 6 Satin Stitch
- 7 Topstitch/Edgestitch
- 8 Basting
- 9 Temporary Altered Stitch Memory

#### Care and Cleaning of the Machine

Cleaning the feed dog and needle areas  
Cleaning and lubricating the hook  
Cleaning the outside of the machine

This class is formatted for owners of the following **BERNINA®** sewing machine models:

- **classic** 1008
- **activa** 220
- **activa** 230PE
- **activa** 240
- **aurora** 430
- **aurora** 440QE
- **artista** 630
- **artista** 640
- **artista** 200

This class is also formatted for owners of the following **bernette®** sewing machine models:

- 55
- 65
- 80e
- 90e



## Introduction

Congratulations on your purchase of a BERNINA® or bernette® for BERNINA® sewing machine!

This workbook is designed to be used in conjunction with the Owners Classes you will take at your BERNINA® dealership, and contains a series of exercises intended to familiarize you with the features of your new BERNINA® or bernette® sewing machine. In addition, you will learn about needles, threads, stabilizers, interfacing, presser feet and accessories, all of which will increase your knowledge of sewing and assist you in achieving success in all of your sewing endeavors.

Once you have completed the exercises designated for your BERNINA® or bernette® machine, attach the sewn samples to the indicated pages and insert the pages into plastic page protectors and store them in a 3-ring binder. They can then be used as a reference tool in the future as you use your machine and explore the creative possibilities it affords you.

BERNINA® of America, Inc. strives to provide its customers not just with quality sewing machines, but with informative publications and classes. Along with providing Owners Classes, your local BERNINA® dealer stocks BERNINA® books and magazines, such as *Features* and *Through the Needle*. Plus, BERNINA® of America, Inc. has a website – [www.berninausa.com](http://www.berninausa.com) – offering free projects, basic sewing information, a glossary of sewing terms, inspirational stories, interviews with creative stitchers, and a variety of articles and postings that appeal to all types of stitchers, no matter which machines are their favorites.

Learn to use your BERNINA® or bernette® machine to its full extent and enjoy being creative with fabric and thread!

My **BERNINA®** or **bernette®** sewing machine model is: \_\_\_\_\_

Serial Number: \_\_\_\_\_

I purchased it on: \_\_\_\_\_

at \_\_\_\_\_

\_\_\_\_\_

\_\_\_\_\_

## Meet Your Feet

### BERNINA® Presser Feet:

- are precision engineered for specific functions
- are Swiss-made for the highest quality
- are one-piece metal feet, making them sturdy and durable
- are easy to change with one hand, requiring no special tools
- have a white shank, making it easier to see the eye of the needle, resulting in easier threading
- are, in some cases, modeled after commercial feet used in factories to increase speed and production with professional looking results
- do the job intended in relation to all types of sewing (ex. garment-making, quilting, home dec, etc.)
- are supported by the best and most complete educational materials in the industry, such as *Feetures* and the BERNINA® website at [www.berninausa.com](http://www.berninausa.com)

### BERNINA®

#### Top Ten Accessory Feet

- 1** Walking Foot #50
- 2** Patchwork Foot #37
- 3** Edgestitch Foot #10/10C
- 4** Freemotion Quilting Foot #29/29C
- 5** Clear Foot #34/34C
- 6** Bulky Overlock Foot #12/12C
- 7** Button Sew-On Foot #18
- 8** Open Embroidery Foot #20/20C
- 9** Clear Applique Foot #23
- 10** Invisible Zipper Foot #35

### bernette® Presser Feet:

- have a white shank, making it easier to see the eye of the needle, resulting in easier threading
- are available for some of the most common sewing tasks such as piping, quilting, couching, etc.

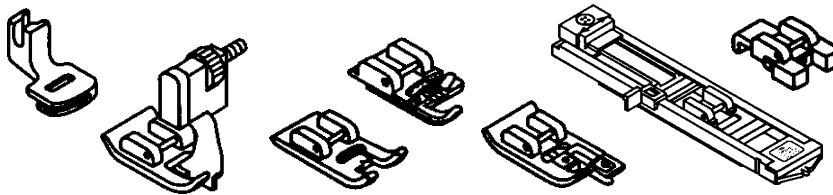

- Walking Foot
- Quilting Foot
- Blindhem Foot
- Satin Stitch Foot
- Darning/Embroidery Foot
- Gathering Foot
- Cording Foot
- Overcasting Foot
- Hemmer Foot

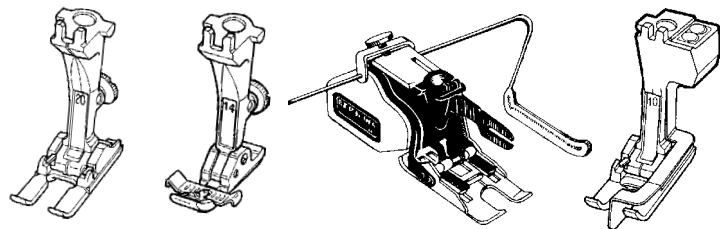

## Sewing Machine Needles

Along with thread, needles are very important to stitch formation. Many “mechanical” problems and damage to fabrics can be traced to a bent, damaged, or incorrect size or type needle. Approximately 60% of all needles are discarded at some stage of production. When selecting the correct needle for any sewing project, consider the following:

*Needle system* – 130/705H

*Needle point* – to assure proper stitch formation and avoid fabric damage

*Needle size* – smaller for lightweight fabrics; larger for heavier fabrics

If the needle is:

*Too small* – the thread can't stay in the groove to form a loop to be picked up by the hook point

*Bent* – thread loop forms too far away from hook point; hook can't enter the loop to form stitch

*Blunt* – needle won't pierce fabric so no thread loop forms to make a stitch

### Need To Know

- Needle should be changed every 4-6 hours of sewing. The needle is the most inexpensive part in your sewing machine but is one of the most crucial for getting good results and keeping your machine running well. Don't let false economy keep you from doing what is best for your sewing projects and your machine.
- European needles are chrome-plated to glide in and out of fabric easily.
- The selected thread should fit in the groove on the front of the needle. If it isn't protected by the groove, a needle with a larger groove should be used.
- Always make sure needles are fully inserted as high as possible, with the flat side to the back.

### Needle Size Conversion

European vs. Domestic

60 = 8	90 = 14	Regardless of the system, the greater the number, the larger the diameter of the needle.
70 = 10	100 = 16	
75 = 11	110 = 18	
80 = 12	120 = 19	

## Notes

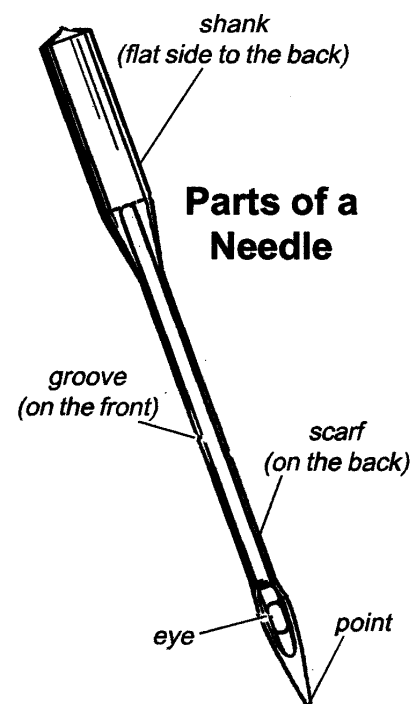



## Sewing Machine Needles

<b>Ball Point</b>	70-90	Has a rounded point. 70 for lingerie, nylon, jersey; 80 for T-shirt; 90 for sweatshirt fleece.	<b>Microtex Sharp (Schmetz)</b>	60-90	A sharp point with a thin shaft. 60-90 corresponds to the weight of the fabric; as the fabric gets heavier or denser, the number is higher. Specially designed for microfiber fabrics.
<b>Stretch</b>	70-90	A stretch needle has a more rounded point and a blue anti-cling coating which helps to prevent skipped stitches in knits and elastic. Sometimes used on Ultrasuede®, vinyl, and plastic.	<b>Microfiber (Lammertz)</b>		
<b>Stretch Double</b>	2.5/75 4.0/75	Two ballpoint needles on one shank; each needle has a large scarf. Used for hemming and for stitching on knit fabric.	<b>Quilting</b>	assorted (75 & 90)	The thin, tapered point of this needle causes less damage to fabric when seaming and cross seaming.
<b>Universal</b>	60-110	A compromise between a sharp and a ballpoint needle; can be used on both wovens and knits. 60 – very fine batiste 70 – broadcloth 80 – trigger and gabardine 90 – denim and twill 100 & 110 – canvas	<b>Topstitch</b>	80-100	A sharp point with a large eye and deep groove. For use with heavier fabrics – the large groove cradles heavier threads.
<b>Double Universal</b>	1.6/70- 8.0/100	Two needles attached to one shank. Used for pintucks, hems, and decorative work.	<b>Embroidery (Schmetz)</b>	75-90	Sharp needle with a large eye and groove; also has a coating and a larger scarf. For use with embroidery thread – prevents shredding of rayon or metallic threads. Two threads may be used through the eye of an 80 or 90 needle.
<b>Triple (Drilling)</b>	3.0/90	Three needles attached to one shank. Used to create mock smocking and other decorative effects.	<b>Metafil (Lammertz)</b>		
<b>Jeans</b>	70-90	Has a sharp point and a shaft that is less prone to flex. The sharpness of the needles makes it better for use on denim and woven fabrics where a clean stitch is desired.	<b>Metafil Double</b>	3.0/75	Two Metafil needles attached to one shaft; for double needle work with embroidery threads.
<b>Jeans Double</b>	4.0/100	Two Jeans needles attached to one shank. For topstitching on denim with heavy thread; can also be used for decorative stitching with metallic thread.	<b>Wing</b>	100- 120	Sharp pointed needle with a non-cutting wedge of metal on each side. Needle makes a hole in the fabric without cutting the threads of the fabric. Used for decorative and heirloom work, such as hemstitching. Works best on natural fibers or on the bias.
			<b>Double Wing</b>	100	One regular needle and one wing needle attached to a single shaft. Use the same as a Wing; makes one large and one regular hole.
			<b>Leather</b>	80-90	Point is a sharp cutting wedge. Used for leather only. Not for vinyl or simulated leathers.



## Thread

Poor quality or the wrong type of thread can cause poor stitches on any machine. Thread passes through the eye of the needle approximately 37 times in a “seesaw” action before it forms a single stitch. Poor quality thread results in crooked and looped stitches, puckered seams, frayed thread, and/or needle breakage. To achieve quality stitches, a sewing machine needs three things: correct thread, correct size needle, and properly adjusted thread tensions.

Several factors such as the fiber, twist, ply, finish, and size of thread must be considered for use with today’s fabrics for fine stitches.

**Staple** – refers to the length of fibers used to twist together to form a single ply. Domestic thread fiber lengths are usually 1½” to 2½” long while European threads use 5½” to 6½” lengths.

**Ply** – number of strands twisted together to make a single thread.

**Roll** – the tendency of thread to roll to the right or left during stitching, causing the stitch to appear slightly crooked. Poor quality threads are more likely to roll.

**Twist** – the crimping of fibers which causes them to interlock firmly into a single ply. Thread should not untwist during stitching. This will cause skipped stitches, thread breakage, crooked stitches, and weak spots in seams.

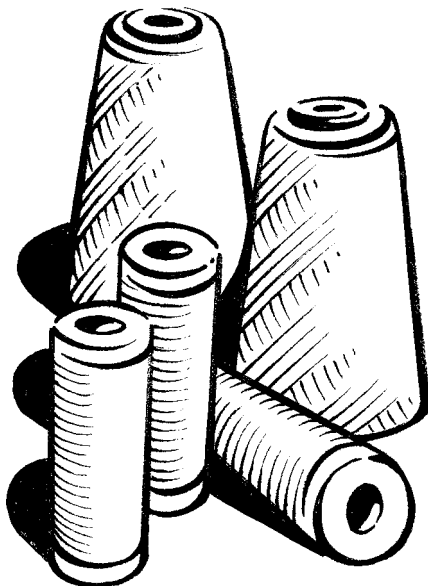

*Right twist* – most American threads are twisted to the right, causing some rolling. This gives average stitch quality.

*Left twist* – Most commercial and imported threads are twisted to the left, giving better than average stitch quality. Left twist resists rolling and makes a larger loop for the hook point to enter, reducing skipped stitches.

## Notes



## Thread

Wearable art embellishment has necessitated the creation and marketing of many new thread types, such as rayons and metallics. Threads made in West Germany are left twist threads; Mettler and Isacord threads are also left twist. To test the twist of a thread: while holding the spool in the left hand, roll the strand of thread towards you with one thumb. Left twist will tighten, right twist will loosen.

**Fiber** – refers to the type of material used to produce the thread.

Some commonly used threads:

- *Polyester 2 ply* – such as Metrosene 100. Good for clothing construction on man-made, natural or blended fabrics. Will tolerate heat up to 450° Fahrenheit.
- *Polyester 3 ply cordonnet* – topstitching or buttonhole twist – such as Mettler 30/3.
- *Cotton 2 ply* – such as Mettler 60/2 – excellent for French Machine Sewing, delicate machine embroidery, piecing and darning.
- *Cotton 2 ply* – such as Mettler 30/2 – loose twist for a soft, shiny look in machine embroidery, applique, and buttonholes.
- *Cotton 3 ply* – such as Mettler 50/3 – excellent for clothing construction on natural fibers. Tighter twist than embroidery cotton thread and less puckering on problem fabrics. Cotton thread stretches less than polyester.
- *Rayon* – a lustrous embroidery thread. Weaker than cotton, it is used for decorative work only.
- *Polyester 2 ply embroidery thread* – Isacord and Polysheen embroidery thread – excellent for embroidery, very abrasion resistant.

### Storage of Thread

Thread does wear out and should be stored with care to keep it usable as long as possible. Extreme moisture may cause thread to swell while very dry conditions can leave it dry and brittle as it ages. Store thread in a covered container (thread box with a lid, cabinet with doors, or drawers that close) if possible to keep it dust-free.

Be wary of old spools of thread recovered from Grandma's sewing box. The fibers may be so weak and brittle that even if it sews into a seam, it may be so unstable that the garment or project will not hold together and the life of the project may be considerably shortened.

## Notes

## Stabilizers & Interfacings

**Tear-Away Stabilizer:** The most commonly used type of stabilizer, designed to provide temporary support of stitching. Placed on the wrong side of the project and carefully pulled away once stitching is complete. Available in three weights – heavy, medium, and light. Multiple lightweight layers may be preferable to one heavy layer, as they are easier to remove. Many adhesive versions have appeared on the market lately, including Stabil-Stick, which has a peel-away backing which exposes the sticky adhesive, and Hydro-Stick, has a water-activated adhesive on one side which provides a secure bond and a high degree of stabilization for very dense and/or intricate designs. Available in white and black.

**Cut-Away Stabilizer:** The most widely used stabilizer in the commercial market. Does not break down under dense stitching, due to the high fiber – rather than paper – content. Excess stabilizer is trimmed away after stitching (leave approximately ¼” of stabilizer around the edges). Remaining stabilizer continues to support stitches throughout life of garment/project. Stabil-Stick and Hydro-Stick are available as cut-away stabilizers; in addition, PolyMesh, described below, is available in a fusible version. Available in white and black.

**Web/Poly-Mesh Type Stabilizer:** A specially formulated cut-away stabilizer developed for use behind lightweight or light-colored fabrics. Available in fusible and non-fusible versions. Available in white, black, and beige.

**Water-Soluble Stabilizer:** Used for backing and topping, in single or multiple layers. Available in two weights. Excellent for decorative stitching and cutwork as there are no remnants of stabilizer left after removal (it dissolves). As a topping, it keeps stitches from being lost in heavily napped fabrics such as velvet and corduroy. Examples: Aqua Film and Badge Master. Aqua Mesh Plus is an adhesive water-soluble stabilizer.

**Iron-On Stabilizer:** A non-woven product similar to paper. Perfect for knits, this tear-away stabilizer is temporarily bonded to the fabric, inhibiting the tendency of the material to stretch.

**Heat Removable Stabilizer:** Woven from strands of fiber that are burned away at a low temperature, heat removable stabilizers are perfect for heirloom stitchery.

## Notes

## Stabilizers & Interfacings

**Liquid/Spray Stabilizers:** Wonderful for sheer fabrics from which all stabilizer must be removed after stitching, these products are painted or sprayed onto the fabric. Several light applications of spray stabilizer are preferable to one heavy application.

**Knit Fusible Interfacing:** A very lightweight, flexible interfacing sometimes used as a stabilizer, it gives permanent support (as an underlining) to a fabric. Perfect for plackets, garment edges, under buttonholes, and anywhere extra body and stability are needed. Can also be used to stabilize decorative stitch work. Available in white, cream, black, and gray; sometimes available in additional colors.

**Woven Fusible Interfacing:** This interfacing is sometimes used as a stabilizer and is generally cut on the bias to provide better drape. Gives a firmer hand or finish than knit or non-woven inter-facings. Used for lapels, facings, and anywhere a great deal of extra body and stability are needed.

### **Sewing and Craft Sprays**

*HRFive Temporary Adhesive Spray:* It's water-soluble, so it washes out completely. Great for basting or holding two layers of fabric and/or batting together. Can be used as a repositionable spray, allowing items to stay sticky but be repositioned on other surfaces. This water-soluble adhesive washes out completely. Works well for securing "hard-to-hoop" items such as collars and cuffs to hooped stabilizer for embroidering. Also works on paper, and be used as a no-show adhesive on vellum.

*606 Fusible Spray:* 606 is used to make any fabric or stabilizer fusible. Apply to the wrong side of the fabric to be fused, using several light coats rather than one heavy coating. The more coats used, the stronger the bond will be. Fuse as directed on product label.

*Fabric Shield:* Used to protect fabrics from dust, dirt, grease, and oil, this spray is water repellent and can be laundered and dry-cleaned.

*HRZero Adhesive Remover Spray:* For removing adhesives, such as quilt sprays and other spray adhesives, as well as labels and tapes, from various surfaces. Use on work surface areas, hoops, needles, frames, quilting frames, stencils, table tops, etc. For use on plastic, metal, wood, glass, stone, and ceramic surfaces. *Not intended for fabric surfaces.*

## Notes



# Straight Stitch/Seaming

- Fabric ..... two pieces firm, woven fabric, each 4" x 6"
- Needle ..... 90/14 Universal
- Thread ..... 30 wt. cotton embroidery, contrasting color
- Presser Foot ..... **BERNINA®** Reverse Pattern Foot #1/1C  
 ..... **BERNINA®** Quilting/Seam Guide  
 ..... **bernette®** Zigzag/Universal Foot  
 ..... **bernette®** seam guide bar
- Stitch ..... straight
- Needle Position ..... center

## Notes

Find the <sup>5</sup>/<sub>8</sub>" engraved guide line on the stitch plate. [Not available on **bernette®** 55.]

Place fabric pieces right sides together and align them with the engraved guide line.

Sew a <sup>5</sup>/<sub>8</sub>" seam on one 6" edge.

Attach and adjust the seam guide and sew a 2" seam on the opposite edge of the fabric.

# Straight Stitch/Seaming Sample

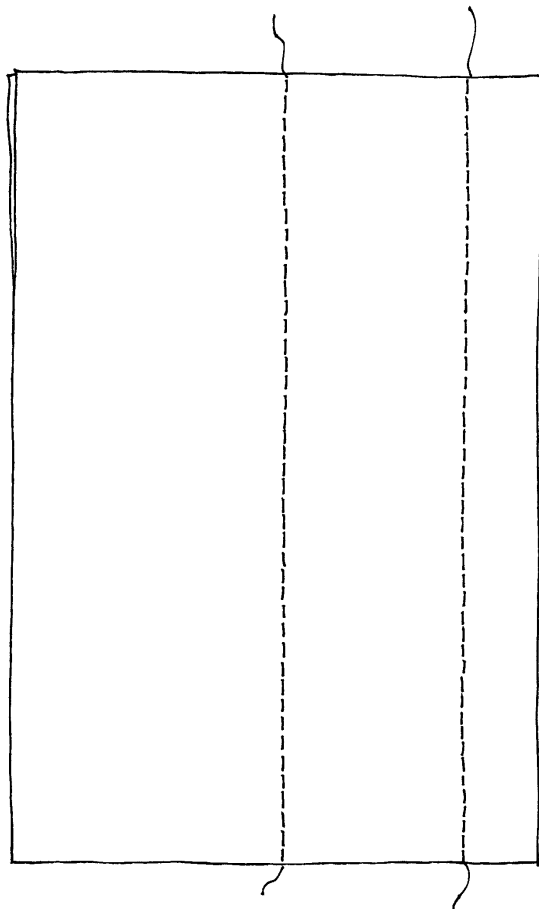

bernette®	55	65	80e	90e
Straight Stitch	2	2	2	2

<b>BERNINA®</b> 1008	220	230PE	240	430	440QE	630	640	200
Straight Stitch	1	1	1	1	1	1	1	1



# Needle Positions Sample

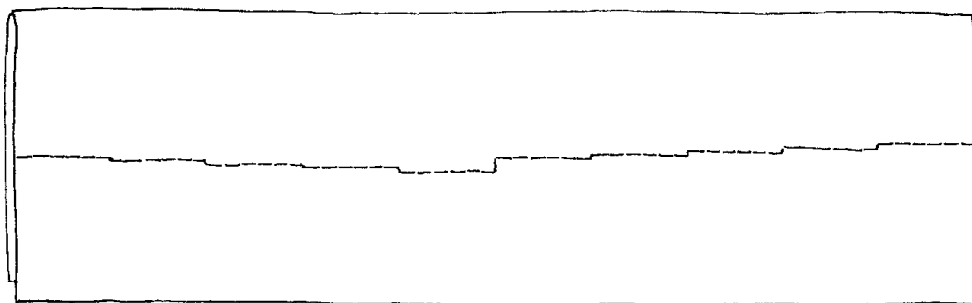

bernette®	55	65	80e	90e
<b>Straight Stitch</b>	2	2	2	2
<b>Needle Position Range</b>	2.5-5mm	3.5-7mm	3.5-7mm	3.5-7mm

<b>BERNINA®</b>	1008	220	230PE	240	430	440QE	630	640	200
<b>Straight Stitch</b>	1	1	1	1	1	1	1	1	1
<b>Needle Positions</b>	5	9	9	9	11	11	11	11	11
<b>Pattern Repeat Function</b>	--	--	--	--	--	--	yes	yes	yes
<b>Needle Down/Up Function</b>	--	yes	yes	yes	yes	yes	yes	yes	yes





# Securing Stitches

Fabric ..... 4 pieces firm, woven fabric, each 4" x 6"  
 Needle ..... 90/14 Universal  
 Thread ..... 30 wt. cotton embroidery, contrasting color  
 Presser Foot ..... **BERNINA®** Reverse Pattern Foot #1 or #1C  
 ..... **bernette®** Zigzag/Universal Foot  
 Additional Accessories ..... Quilting/Seam Guide  
 ..... Seam Guide with Rulers  
 ..... **bernette®** Seam Guide Bar  
 Stitches ..... straight  
 ..... securing stitch and/or quilters securing stitch  
 ..... feather Stitch  
 Needle Position ..... center

*Row 1 - Straight Stitch:*

Find the 5/8" guide line on the stitch plate. [Not available on **bernette®** 55.] Fold one piece of fabric in half lengthwise. Place it under the presser foot; align one 6" edge with the 5/8" guide line.

Select straight stitch. Sew a few stitches forward, then press the **Quick Reverse Button/Lever**; sew a few stitches backward; machine will sew in reverse until the **Quick Reverse Button/Lever** is released. Continue stitching the seam; secure the end in the same way.

**BERNINA® models only:**

*Row 2 - Securing Stitch or Quilter's Securing Stitch:*

Attach the Quilting/Seam Guide or Seam Guide with Rulers to the foot. Set the guide 5/8" from the center needle position. Fold another piece of fabric; align the raw edges with the guide.

Select the Securing Stitch. Begin to sew; machine will automatically secure the stitching, then continue stitching forward. At the end of the seam, press and release the Quick Reverse button. The machine will automatically secure the stitching, then stop.

*Sample 3 - Securing Function:*

Place remaining two fabric pieces wrong sides together. Attach one of the Seam Guides with Rulers to presser foot. Set guide 2" from needle; select a feather stitch. Engage the Securing Function, if available; machine will automatically secure the stitches at beginning and end of every pattern repeat. Turn the Securing function off after the first stitch, then re-engage when approaching the end.

## Notes

**Securing Stitch:**  
 Five straight stitches forward and back at beginning; five stitches backward and forward at end.

**Quilters Securing Stitch:**  
 Several very short stitches at beginning and end of straight stitching.

**Securing Function:**  
 Several very short stitches at beginning and end of stitching; can be applied to decorative as well as straight stitches.

# Securing Stitches Sample

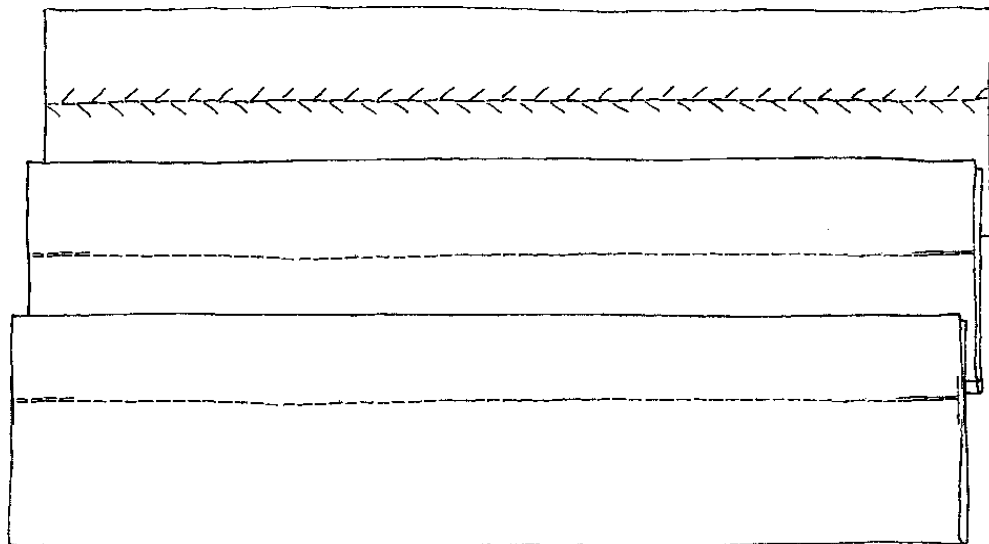

bernette®	55	65	80e	90e
<b>Straight Stitch</b>	2	2	2	2
<b>Securing Stitch</b>	--	--	--	--
<b>Securing Function</b>	--	--	--	--

<b>BERNINA®</b>	1008	220	230PE	240	430	440QE	630	640	200
<b>Securing and/or Quilters Securing Stitch</b>	--/--	5/--	--/5	5/--	5/--	5/--	5/324	5/324	5/324
<b>Feather Stitch</b>	--	45	28	44	53	48	332	332	332
<b>Securing Function</b>	--	--	--	--	yes	yes	yes	yes	yes



## Stitching Corners

Fabric ..... two pieces firm, woven fabric, each 4" x 6"  
Stabilizer ..... lightweight tear-away, 4" x 6"  
Needle ..... 90/14 Universal  
Thread ..... 30 wt. cotton embroidery, contrasting color  
Presser Foot ..... **BERNINA®** Reverse Pattern Foot #1/1C  
..... **bernette®** Zigzag/Universal Foot  
Stitch ..... straight

## Notes

### **BERNINA®**

Select straight stitch.

Place fabric pieces right sides together.

Place the fabric under the foot with the top edge even with the horizontal line behind the foot. The right edge should be even with the  $\frac{5}{8}$ " seam line.

Engage the Needle Down function, if available.

Sew until the bottom edge touches the horizontal line in front of the needle; stop.

Pivot, using FHS (Free Hand System) if available. Continue sewing until you reach the next corner; repeat the pivot.

Stitch 3 sides of this sample.

*Note: For crisply turned corners, take two small stitches diagonally across corner before completing the pivot.*

### **bernette®**

Draw a line  $\frac{5}{8}$ " from each corner of one fabric square.

Select straight stitch.

Place fabric pieces right sides together.

Place fabric under foot, top edge even with 2nd horizontal line behind foot (not available on 55). Right edge should be even with the  $\frac{5}{8}$ " seam line.

**80e & 90e:** Engage Needle Down function; audio signal will beep once. *Note: To take a single stitch, press Needle Up/Down two times.*

Sew until the needle is  $\frac{5}{8}$ " from the end of the fabric.

Pivot. Continue sewing until you come to the next corner; repeat the pivot.

Stitch three sides of this sample.

*Note: For crisply turned corners, take two small stitches diagonally across corner before completing the pivot.*

# Stitching Corners Sample

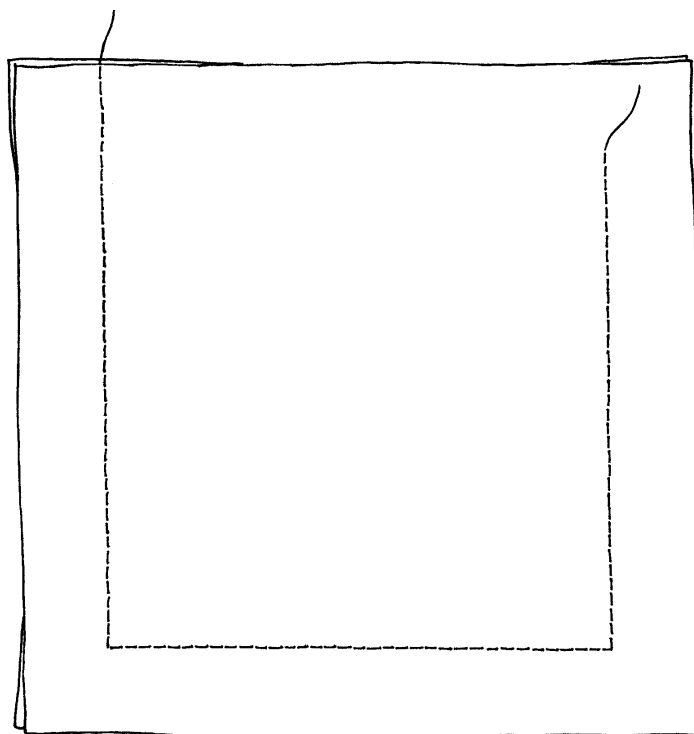

bernette®	55	65	80e	90e
Needle Down/Up	--	--	yes	yes

BERNINA®	1008	220	230PE	240	430	440QE	630	640	200
Needle Down/Up Function	--	yes	yes	yes	yes	yes	yes	yes	yes
Freehand System	--	optional	optional	yes	yes	yes	yes	yes	yes



## Zigzag/Oversewing Edges

Fabric ..... firm, woven fabric, 4" x 6"  
Needle ..... 90/14 Embroidery  
Thread ..... 30 wt. cotton embroidery, contrasting color  
Presser Foot ..... **BERNINA®** Reverse Pattern Foot #1 or #1C  
..... **bernette®** Zigzag/Universal Foot  
Stitch ..... zigzag stitch  
Needle Position ..... center **or** far right

### Notes

Select the Zigzag Stitch (width = 4, length = 2).

Finish one 6" edge using the following steps.

Guide edge of fabric under the middle of the presser foot – **or** –  
Move needle position to far right; sew using the inside edge  
of the right toe as a guide.

The needle should go into the fabric on one stroke of the needle  
and over the edge on the next stroke.

Do not use too long a stitch or too wide a stitch; the edge should  
lie flat, not roll.

Match the weight of the thread to the weight of the fabric.

Trim and mount the sample.



# Zigzag/Oversewing Edges Sample

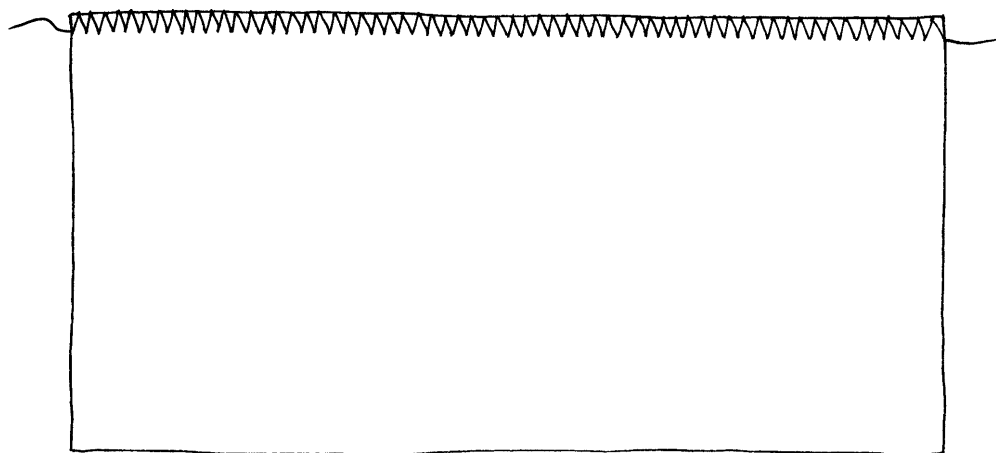

bernette®	55	65	80e	90e
Zigzag Stitch	3	3	3	3

BERNINA®	1008	220	230PE	240	430	440QE	630	640	200
Zigzag Stitch	2	2	2	2	2	2	2	2	2
Needle Positions	5	9	9	9	11	11	11	11	11

# Satin Stitch

Fabric ..... firm, woven fabric, 6" x 8"  
 Stabilizer ..... tear-away, 4" x 6"  
 Needle ..... 90/14 Embroidery  
 Thread ..... 30 wt. cotton embroidery, contrasting color  
 Presser Foot .... **BERNINA®** Open Embroidery Foot #20 or #20C  
   **or BERNINA®** Embroidery Foot #6  
   **or BERNINA®** Clear Embroidery Foot #39  
   bernette® Satin Stitch Foot  
 Extra Accessory. Gold Latch Bobbin Case (*artista* 200/640 only)  
 Stitch ..... zigzag stitch  
 Needle Position ..... as indicated

## Notes

Fold fabric in half to 4" x 6". Use stabilizer as needed.

Select the Zigzag Stitch. Change the stitch length to satin stitch and the stitch width to the widest possible.

Thread the bobbin thread through the eye in the bobbin case finger if using a machine with a CB hook system. For machines with a rotary bobbin system, loosen the needle tension slightly and use the Gold Latch Bobbin Case.

Move the needle position to the center. Sew along the center of the fabric about 1", then, while continuing to sew, decrease the stitch width to taper the stitch to 0mm. Continue sewing, widening the stitch back to maximum. Repeat until stitching reaches end of fabric.

### **BERNINA®** models only:

Move the needle position all the way to the left. Position the raw edge of the fabric on the 3/8" line (on the right side of the stitch plate). Stitch, tapering and widening the satin stitch while sewing.

Move the needle position all the way to the right. Position the fold of the fabric on the 3/8" line (on the left side of the stitch plate). Stitch along the right side of the fabric, tapering and widening the stitching while sewing.

*Note: A preprogrammed satin stitch is available on **artista** models 200/630/640: stitch #354 in the Quilt Stitch menu.*



# Satin Stitch Sample

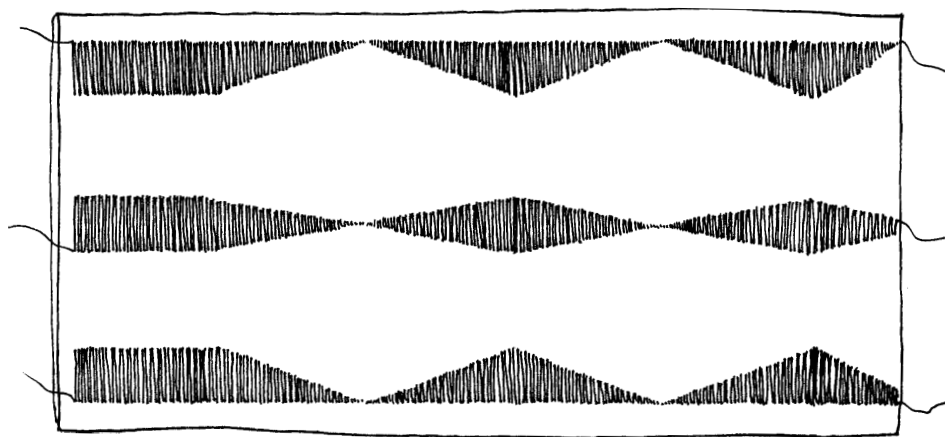

bernette®	55	65	80e	90e
Zigzag Stitch	3	3	3	3
Bobbin Hook System (Oscillating/O or Rotary/R)	O	R	R	R

<b>BERNINA®</b> 1008	220	230PE	240	430	440QE	630	640	200
Zigzag Stitch	2	2	2	2	2	2	2	2
Bobbin Hook System (Oscillating/CB or Rotary/R)	CB	CB	CB	CB	CB	CB	R	R

# Topstitch/Edgestitch

Fabric ..... firm, woven fabric, two pieces, 4" x 6" each  
Needle ..... 90/14 Embroidery  
Thread ..... 30 wt. cotton embroidery, contrasting color  
Presser Foot ..... **BERNINA®** Edgestitch Foot #10 or #10C  
..... **bernette®** Blindhem Foot  
Stitch ..... triple straight stitch  
Needle Position ..... as indicated

## Notes

Place fabrics right sides together. Stitch together with a  $\frac{5}{8}$ " seam along one 6" side. Finger-press the seam open.

Select the triple straight stitch.

### **BERNINA®**

From the right side, position the blade of Foot #10/10C in the ditch of the seam. Move the needle position two places to the left.

Stitch the length of the seam.

If available, select the Long Stitch function. If not available, increase the stitch length to 5mm.

Move the needle all the way to the right, if available.

Starting at the top of the seam again, stitch the length of the seam.

### **bernette®**

Move the white blade  $\frac{1}{8}$ " from the needle. Position the blade in the ditch of the seam.

Stitch the length of the seam.

Increase the stitch length to 5mm.

Move the needle all the way to the left.

Move white blade to line up with right side of the needle opening of the presser foot.

With the guide in the ditch of the seam, and starting at the top of the seam again, stitch the length of the seam.

# Topstitch/Edgestitch Sample

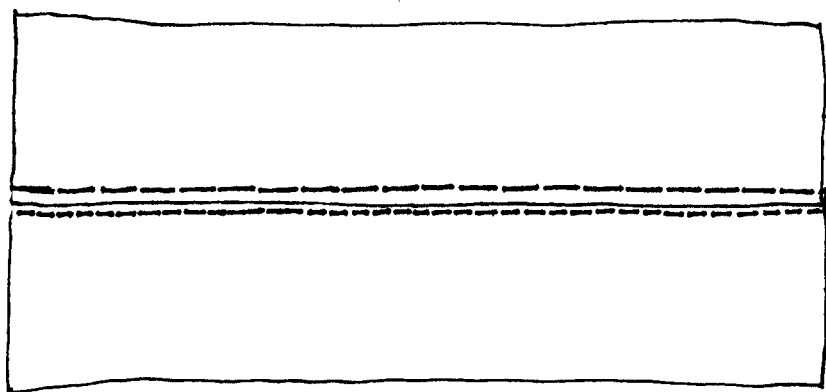

bernette®	55	65	80e	90e
Triple Straight Stitch	7	15	51	51

BERNINA®	1008	220	230PE	240	430	440QE	630	640	200
Triple Straight Stitch	9	6	6	6	6	6	6	6	6
Needle Positions	5	9	9	9	11	11	11	11	11
Long Stitch Function	--	--	--	--	--	--	--	yes	yes



# Basting

Fabric ..... firm, woven fabric, 2 pieces, 4" x 6" each  
 Needle ..... 90/14 Embroidery  
 Thread ..... 30 wt. cotton embroidery, contrasting color  
 Foot **BERNINA®** Reverse Pattern Foot #1/1C (1008, 430/440 & 200) – *or* –  
 ..... **BERNINA®** Darning Foot #9 (220/230/240 & 630/640)  
 ..... *bernette®* Zigzag/Universal Foot  
 Stitches ..... straight  
 ..... basting  
 Needle Position ..... center

## Notes

Place fabric pieces right sides together.

**BERNINA®**  
*aurora* 430/440  
 & *artista* 200  
 Select preprogrammed basting stitch, if available, *or* straight stitch (preprogrammed length). Engage Long Stitch function if available.

Attach Foot #1/1C. Baste a  $\frac{5}{8}$ " seam along one side of fabric.

Adjust stitch length to 5mm; baste another  $\frac{5}{8}$ " seam along opposite side of fabric.

*activa* 220/230/240  
 & *artista* 630/640  
 Select preprogrammed basting stitch. Attach Foot #9 and lower feed dog.

Sew one stitch; pull fabric desired length (2.5mm) of stitch from behind machine. Take one stitch. Repeat as needed.

Repeat for opposite edge, moving fabric 5mm or more between stitches.

*bernette®*  
 & **BERNINA®** 1008  
 Using a straight stitch with a length of 5mm, baste a  $\frac{5}{8}$ " seam along one side of fabric.

# Basting Sample

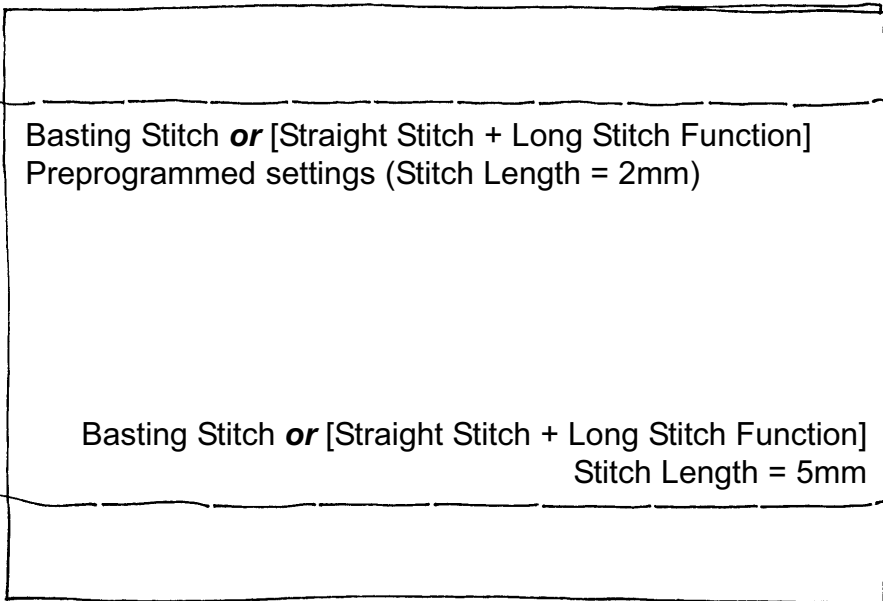

bernette®	55	65	80e	90e
<b>Straight Stitch</b>	2	2	2	2

	<b>BERNINA® 1008</b>	<b>220</b>	<b>230PE</b>	<b>240</b>	<b>430</b>	<b>440QE</b>	<b>630</b>	<b>640</b>	<b>200</b>
<b>Basting Stitch</b>	--	16	19	21	19	21	30	30	21
<b>Long Stitch Function</b>	--	--	--	--	--	--	--	yes	yes



BERNINA® *electronic models only*

## Temporary Altered Stitch Memory

Fabric .....	firm, woven fabric, 6" x 8"
Stabilizer .....	tear-away, 4" x 6"
Needle .....	90/14 Embroidery
Thread .....	30 wt. cotton embroidery, contrasting color
Presser Foot .....	<b>BERNINA®</b> Reverse Pattern Foot #1 or #1C
Stitch .....	heart
Needle Position .....	center

### Notes

Fold fabric to 4" x 6". Insert stabilizer between layers.

Select the heart or other pattern stitch. Stitch two patterns and stop.

*Note: If available, select the Pattern Repeat function 2x. Stitch; machine will automatically stop after two repeats.*

– or –

*Note: If available, touch Pattern End while sewing second pattern; machine will automatically stop at the end of the current pattern.*

Reduce the stitch width to 4mm (6mm for the **artista** 640 and 200).  
Stitch two more repeats.

Select Vertical Mirror Image function if available. Stitch two more repeats.

Select the zigzag stitch from Satin Stitching exercise (pages 22-23).

*Note: The sewing computer remembered all the changes made to the stitch – length, width, and needle position.*

*All models except **artista** 630/640/200: Disengage the Mirror Image function, as it remains active until turned off.*

Select heart stitch again. Sew. *Note: The sewing computer remembered all changes made to heart stitch, as well as to zigzag.*

*Note: In addition to stitch width, length, and needle position, the **artista** 630/640/200 sewing computer remembers changes to the Mirror Image and Pattern Repeat functions. Temporary Altered Memory will be explored further in Class 6, **artista** Extras.*

Return the active stitch to default settings by touching **clr** (clear).

# Temporary Altered Stitch Memory Sample

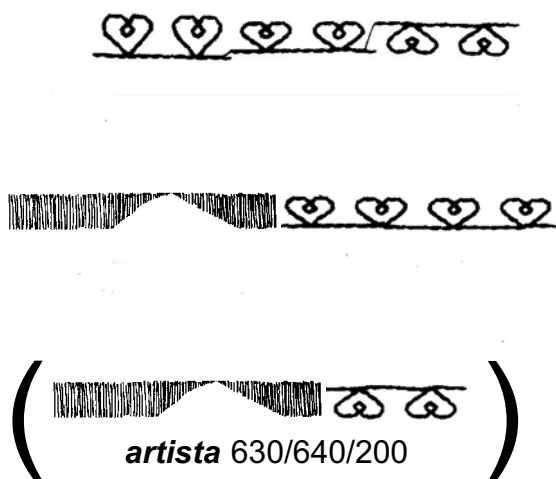

<b>BERNINA®</b>	<b>1008</b>	<b>220</b>	<b>230PE</b>	<b>240</b>	<b>430</b>	<b>440QE</b>	<b>630</b>	<b>640</b>	<b>200</b>
<b>Heart Stitch</b>	--	32	46	85	127	156	712	712	712
<b>Pattern End</b>	--	--	yes	yes	yes	yes	yes	yes	yes
<b>Mirror Image</b>	--	--	--	yes	yes	yes	yes	yes	yes
<b>Pattern Extend</b>	--	--	--	--	--	--	yes	yes	yes
<b>Temporary Stitch Memory</b>	--	yes	yes	yes	yes	yes	yes	yes	yes



# Class 1

## Product Reference List

### General Information

- Feet-ures*, Volumes 1 and 2
  - BERNINA® Edgestitch Foot #10 **or**
  - BERNINA® Edgestitch Foot #10C
  - bernette® Satin Stitch Foot
  - bernette® Blindhem Foot
  - Bobbin holders for accessory cabinets
  - Foot holders for accessory cabinets
  - Deluxe Accessory Box
  - Tapestry Accessory Bag
  - Thread Storage Box
  - Bobbins
  - Spool Bobbin Holders
  - Magnetic Pin Cushion
  - Magnetic Bobbin Holder
  - Straight Stitch Plate
  - Seam Sealant
  - Thread Stand
  - Supplementary Thread Guide
  - Multi-spool thread holder
  - Left guide
  - Seam Guide with Rulers (right and left)
  - Set of Magnifying Lenses
  - Suitcase System
  
  - Quilters' Resource Nifty Notions Scissors
    - Dressmaker's shears
    - Trimming scissors
    - Applique Scissors
- Needles
    - Universal 60/70/80/90/100/110/120
    - Double 2.0/2.5/3.0/4.0/6.0/8.0
    - Wing Single/Double
    - Embroidery 75/90
    - Quilting 80/90
    - Stretch 75/90
    - Ballpoint 60/70/80/90/100/110/120
  
  - OESD Stabilizers
    - Aqua Film
    - Tear-away
    - Cut-away
    - Poly Mesh
    - Fusible Poly Mesh
    - Hydro Stick
    - HRFive Temporary Adhesive Spray
    - 606 Spray and Fix
    - Fabric Shield
  
  - Thread
    - Isacord Polyester
    - YLI (variety)
    - Mettler Cotton Embroidery
    - Mettler Metrosene Polyester
    - Mettler Silk-finish Cotton

## **Class 2 Practical Stitching Class Overview**

### **Stretch Seam Samples**

- 1 Zigzag Seam
- 2 Super Stretch Seam
- 3 Vari-Overlock Seam
- 4 Flat Joining Seam

### **Hem & Edging Samples**

- 5 Blind Hem
- 6 Handpicked Hem
- 7 Double Needle Hem
- 8 Jeans Hem
- 9 Shell Edge
- 10 Rolled and Whipped Edge

This class is formatted for owners of the following models of BERNINA® sewing machines:

- **classic** 1008
- **activa** 220
- **activa** 230PE
- **activa** 240
- **aurora** 430
- **aurora** 440QE
- **artista** 630
- **artista** 640
- **artista** 200

This class is also formatted for owners of the following bernette® sewing machine models:

- 55
- 65
- 80e
- 90e



# Zigzag Seam

Fabric ..... firm knit fabric 4" x 6"  
Needle ..... 80/12 Universal  
Thread ..... all-purpose  
Presser Foot ..... **BERNINA®** Reverse Pattern Foot #1 or #1C  
..... **bernette®** Zigzag/Universal Foot  
Stitch ..... zigzag  
Needle Position ..... center

## Notes

Cut the fabric piece in half lengthwise, creating two pieces, 2" x 6" each.

Select the Zigzag Stitch – stitch width of 1.5mm and stitch length of approximately 1.5mm (generally between 1.4mm and 1.6mm).

Position the fabric to produce a <sup>5</sup>/<sub>8</sub>" seam down one side.

Stitch the seam.

Clip one seam allowance in the middle.

Press one part of the seam open and leave the other half closed so the stitch is visible.

Trim and mount the sample.

# Zigzag Seam Sample

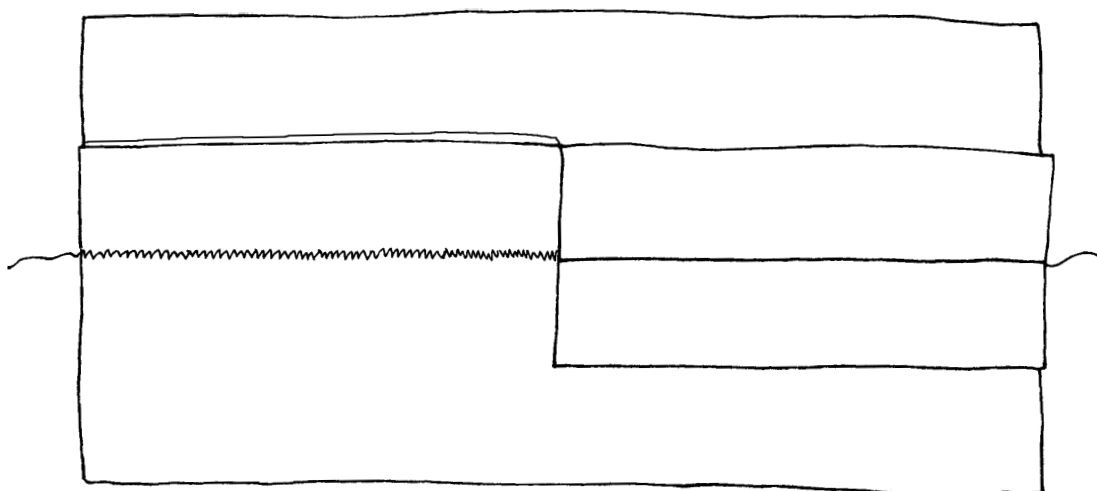

bernette®	<b>55</b>	<b>65</b>	<b>80e</b>	<b>90e</b>
Zigzag Stitch	3	3	3	3

<b>BERNINA® 1008</b>	<b>220</b>	<b>230PE</b>	<b>240</b>	<b>430</b>	<b>440QE</b>	<b>630</b>	<b>640</b>	<b>200</b>
Zigzag Stitch	2	2	2	2	2	2	2	2



**BERNINA®** models only

# Super Stretch Seam

- Fabric ..... heavy double knit, 4" x 6"
- Needle ..... 80/12 Universal
- Thread ..... all-purpose
- Presser Foot ..... **BERNINA®** Reverse Pattern Foot #1/1C
- Stitch ..... stretch
- Needle Position ..... center

## Notes

Cut fabric in half lengthwise creating two pieces, 2" x 6" each.

Select the Stretch Stitch.

Position the fabric to produce a <sup>5</sup>/<sub>8</sub>" seam down one side.

Stitch the seam; if fabric stretches, lighten the presser foot pressure (if available).

Clip one seam allowance in the middle and press one part of the seam open.

Trim and mount the sample.

*Note: This stitch is good for an open seam on all knit fabrics; works well for sportswear.*

# Super Stretch Seam Sample

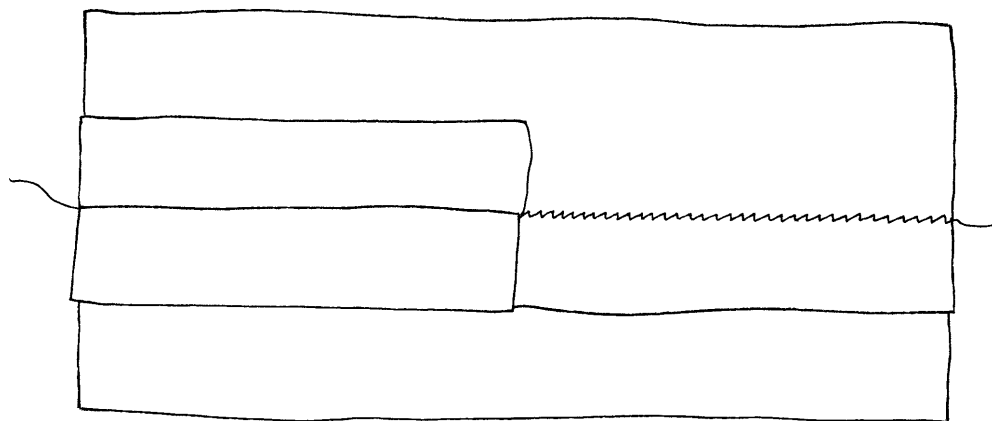

<b>BERNINA® 1008</b>	<b>220</b>	<b>230PE</b>	<b>240</b>	<b>430</b>	<b>440QE</b>	<b>630</b>	<b>640</b>	<b>200</b>
<b>Super Stretch Stitch</b>	--	9	9	9	9	9	11	11
<b>Presser Foot Pressure Control</b>	--	--	--	--	yes	yes	yes	yes



## Vari-Overlock Seam

Fabric ..... cotton interlock 4" x 6"  
ribbing, 2" x 6"  
Needle ..... 80/12 Universal  
Thread ..... all-purpose  
Presser Foot ..... **BERNINA®** Overlock Foot #2 or #2A  
..... **bernette®** Overcasting Foot  
Stitch ..... vari-overlock or overlock  
Needle Position ..... center

### Notes

Cut an inside curve in one corner of fabric to simulate a neckline.

Select the Vari-Overlock Stitch.

If available, engage the Needle Down function.

Place folded ribbing along the curved edge of the fabric (ribbing and fabric, right sides together).

**BERNINA®**: Guide the raw edges of the fabric under the pin of the foot and stitch; **bernette®**: Guide the fabric against the blade of the foot. Adjust stitch length and width if needed. If available, use the FHS (Free Hand System) to maneuver the curve; adjust the fabrics as needed.

Trim the sample and mount as shown.

# Vari-Overlock Seam Sample

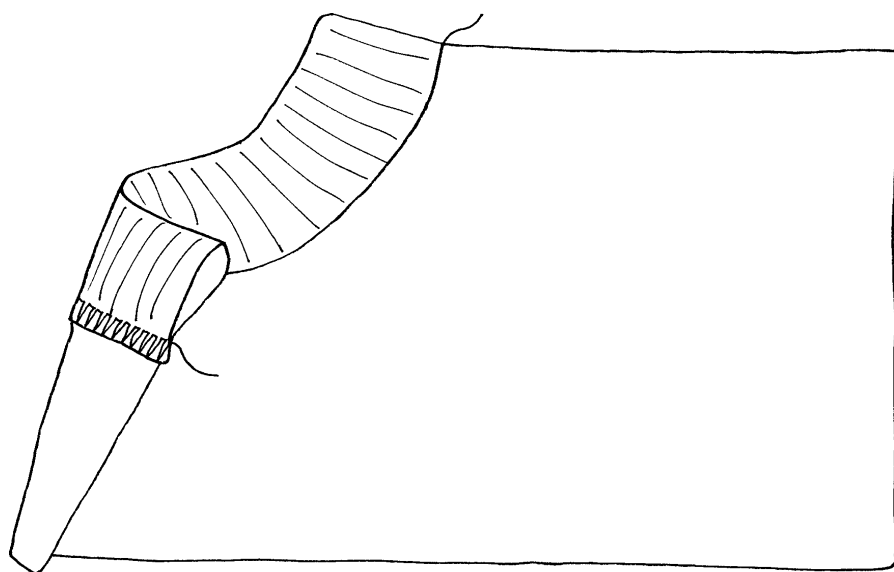

bernette®	55	65	80e	90e
Overlock Stitch	5	6	6	6
Needle Up/Down	--	--	yes	yes

	<b>BERNINA® 1008</b>	<b>220</b>	<b>230PE</b>	<b>240</b>	<b>430</b>	<b>440QE</b>	<b>630</b>	<b>640</b>	<b>200</b>
Vari- Overlock Stitch	3	3	3	3	3	3	3	3	3
Needle Up/Down	--	yes	yes	yes	yes	yes	yes	yes	yes
Freehand System	--	optional	optional	yes	yes	yes	yes	yes	yes





## Flat Joining Seam

Fabric ..... two pieces terry cloth, 4" x 6" each  
Needle ..... 90/14 Universal  
Thread ..... all-purpose  
Presser Foot ..... **BERNINA®** Reverse Pattern Foot #1/1C **or**  
..... **BERNINA®** Clear Foot #34/34C  
..... **bernette®** Zigzag/Universal Foot  
Stitches ..... stretch overlock or towelling stitch  
Needle Position ..... center

### Notes

Select the Stretch Overlock stitch.

Cut a  $\frac{5}{8}$ " seam allowance off one piece of fabric along one long edge.

Mark a line on the other piece of fabric,  $\frac{5}{8}$ " from one long edge. This will be the right-hand piece of fabric.

Overlap the fabric edges left over right, aligning the left raw edge with the drawn line on the right-hand piece.

Stitch along the raw edge. Turn the fabric over and stitch along the remaining raw edge.

*NOTE: This is a great seam technique to use on bulky fabrics such as terry cloth.*

# Flat Joining Seam Sample

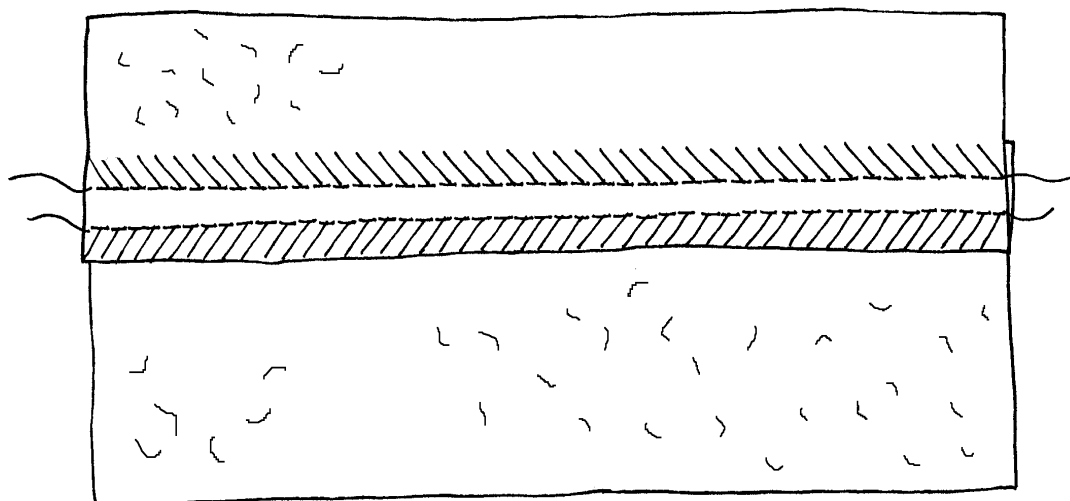

<b>bernette®</b>	<b>55</b>	<b>65</b>	<b>80e</b>	<b>90e</b>
<b>Stretch Overlock Stitch</b>	10	13	S5	S5

<b>BERNINA®</b>	<b>1008</b>	<b>220</b>	<b>230PE</b>	<b>240</b>	<b>430</b>	<b>440QE</b>	<b>630</b>	<b>640</b>	<b>200</b>
<b>Stretch Overlock Stitch</b>	11	15	17	19	--	23	13	13	13



# Blind Hem

Fabric ..... heavy flannel, 6" x 8"  
 Needle ..... 80/12 Universal  
 Thread ..... 60 weight cotton embroidery thread  
 Foot .. **BERNINA®** Reverse Pattern Foot #1/1C (1008, 430/440 & 200) *or*  
 .... **BERNINA®** Darning Foot #9 (220/230/240 & 630/640) *and*  
 ..... **BERNINA®** Blind Hem Foot #5 (all models)  
 ..... **bernette®** Zigzag/Universal Foot *and*  
 ..... **bernette®** Blind Hem Foot  
 Stitch ..... zigzag  
 ..... blindstitch  
 Needle Position ..... as needed

## Notes

Finish one 6" edge of the fabric by oversewing with a zigzag stitch (see pages 20-21).

Fold a 2" hem to the wrong side of the fabric and press.

**BERNINA®**  
 Select a Basting Stitch (see pages 26-27) and baste hem in place, sewing about ¼" from the raw edge.  
  
 Select the Blindstitch and attach Blind Hem Foot #5 to machine.

**bernette®**  
 Select a Basting Stitch (see pages 26-27) and baste the hem in place, sewing about ¼" from the raw edge.  
  
 Select Blindstitch and attach blindhem foot to the machine. Lengthen blindstitch to 5mm.

Fold hem back to the right side over the basting line.

Sew on the extended hem allowance, keeping the folded edge next to the guide on the foot.

Adjust the stitch width (**BERNINA®**) or white guide (**bernette®**) if needed so that the needle barely stitches into the fold.

Mount the sample with the edges folded back as shown.

# Blind Hem Sample

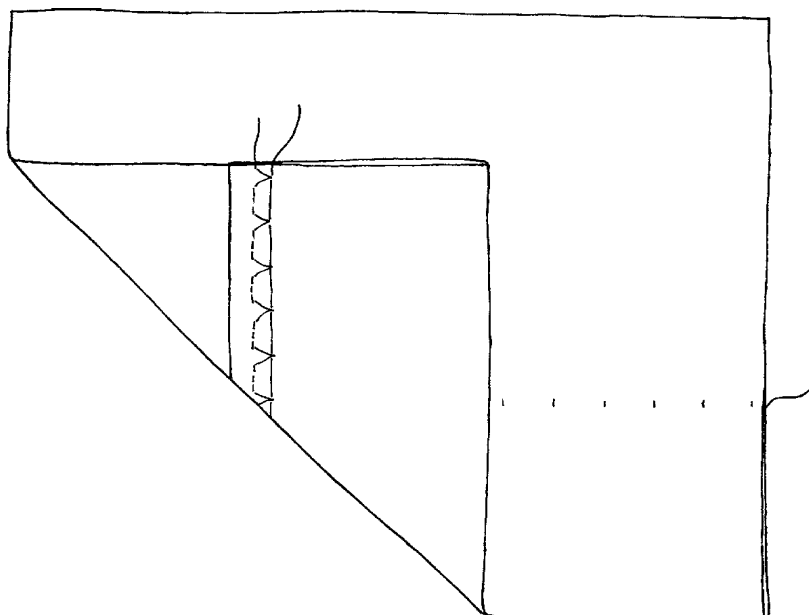

bernette®	55	65	80e	90e
Zigzag Stitch	3	3	3	3
Blindstitch	4	5	12	13

BERNINA®	1008	220	230PE	240	430	440QE	630	640	200
Zigzag Stitch	2	2	2	2	2	2	2	2	2
Basting Stitch	--	16	19	21	19	20	30	30	21
Blindstitch	3	7	7	7	7	7	9	9	9



# Handpicked Hem

Fabric ..... lightweight broadcloth, 6" x 8"  
Needle ..... 80/12 Universal  
Thread ..... 60 weight cotton embroidery thread  
Presser Foot ..... **BERNINA®** Blind Hem Foot #5  
..... **bernette®** Blind Hem Foot  
Stitch ..... blindstitch  
Needle Position ..... as needed

## Notes

Turn up a 1" hem along one of the 6" edges and press.

Turn up the depth of the hem again and press.

Fold the entire hem toward the right side of the garment, so that the garment fold is almost even with the top edge of the hem. A scant  $\frac{1}{8}$ " to  $\frac{1}{16}$ " of hem edge should be visible. This will ensure that both folds are caught by the blind hem stitch.

Place the fabric under the foot just as a traditional blind hem would be placed.

Sew the hem with Blindstitch, making sure that the zigzag catches both folds while the straight stitch falls off the edge and stitches in air forming a chain along the upper hem edge. Adjust stitch width if needed.

Press and mount the sample.

# Handpicked Hem Sample

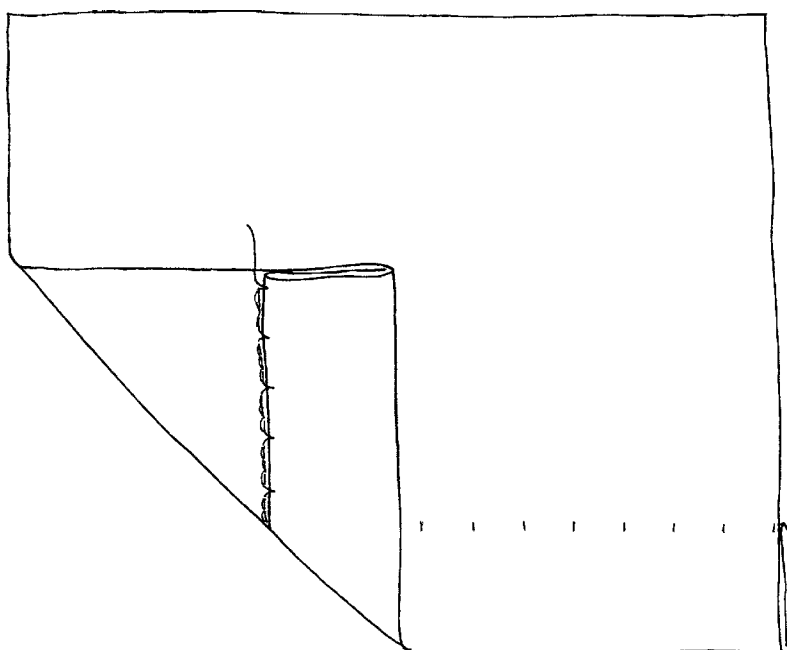

bernette®	<b>55</b>	<b>65</b>	<b>80e</b>	<b>90e</b>
Blindstitch	4	5	12	13

<b>BERNINA® 1008</b>	<b>220</b>	<b>230PE</b>	<b>240</b>	<b>430</b>	<b>440QE</b>	<b>630</b>	<b>640</b>	<b>200</b>
Blindstitch	3	7	7	7	7	9	9	9



## Double Needle Hem

Fabric ..... cotton interlock, 6" x 8"  
 Needle ..... Double, 3.0/80  
 Thread ..... all-purpose, 2 colors  
 Presser Foot ..... **BERNINA®** Reverse Pattern Foot #1/1C  
 ..... **bernette®** Zigzag/Universal Foot  
 Stitches ..... as needed  
 Needle Position ..... center

Turn up a 2" hem along one of the 6" edges and press.

**bernette® only:** When threading the right needle, skip last guide.

Thread the needles with two different colors of thread.

If available, select the Double Needle Limitation or Security Program, and set for the 3.0mm Double Needle.

*Note: If these features are not available, check to be sure the needles will not strike the foot by turning the handwheel to "walk" the machine through the first stitch.*

Place the folded edge of the fabric along the 1" guideline on the right side of the stitch plate. (**bernette® 55 only:** The 1" guide is the one farthest from the needle.)

Select the straight stitch; sew half of the hem.

Select the suggested stitch or experiment with similar stitches; stitch the remainder of the seam.

Trim excess fabric from the wrong side of the hem.

Press and mount the sample.

*Note: This is a good stitch to use when hemming T-shirts and pajamas. You can use other stitches with a double needle for other types of fabrics.*

### Notes

#### Manual Double Needle "Limitation"

To calculate the maximum stitch width which can be stitched by any Double needle, subtract the width of the needle from the maximum stitch width of your sewing machine.

For example:  
 $5.5\text{mm} - 2.0\text{mm} = 3.5\text{mm}$

#### Double Needle Threading

Use a supplementary spool holder and attach a supplementary thread guide to the machine, if available. Thread as usual, placing one thread to the left of the tension disc and through the eye of the left needle; thread the other to the right of the tension disk and through the eye of the right needle.

# Double Needle Hem Sample

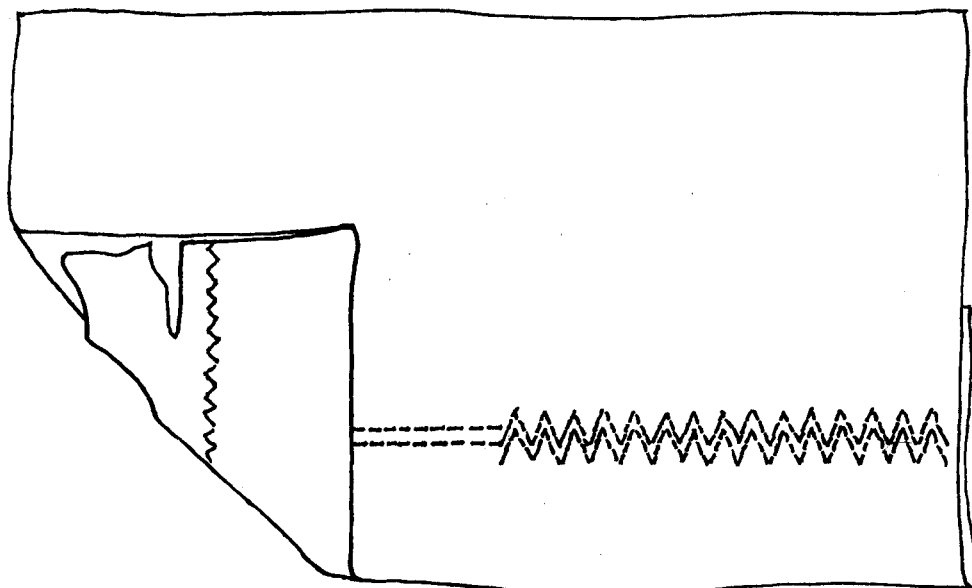

bernette®	55	65	80e	90e
<b>Straight Stitch</b>	2	2	2	2
<b>Suggested Stitch</b>	5	4	4	4

<b>BERNINA® 1008</b>	<b>220</b>	<b>230PE</b>	<b>240</b>	<b>430</b>	<b>440QE</b>	<b>630</b>	<b>640</b>	<b>200</b>
<b>Straight Stitch</b>	1	1	1	1	1	1	1	1
<b>Suggested Stitch</b>	7	4 SL = 2.5	4 SL = 2.5	4 SL = 2.5	4 SL = 2.5	4 SL = 2.5	16	16
<b>Specialty Needle Function</b>	--	--	--	--	--	--	security	security





# Jeans Hem

Fabric ..... denim, 4" x 6"  
 Needle ..... Jeans, 100/16 or 110/18  
 Thread ..... all-purpose  
 Presser Foot ..... **BERNINA®** Jeans Foot #8  
 ..... **bernette®** Zigzag/Universal Foot **or**  
 ..... **bernette®** Quilting Foot  
 Stitch ..... straight  
 Needle Position ..... center

## Notes

Cut fabric in two pieces, 4" x 3" each.

Insert a Jeans needle and select the Straight Stitch.

With right sides together, sew a <sup>5</sup>/<sub>8</sub>" seam along one 4" side.  
 Press seam to one side.

Topstitch, using the edge of the foot along the seam as a guide,  
 and stitching through the seam allowances.

Turn up the lower edge twice, about <sup>3</sup>/<sub>8</sub>" each time.

Topstitch the hem in place, about <sup>1</sup>/<sub>8</sub>" from the upper edge  
 of the hem.

Press and mount the sample.

*Hint: Sew toward the "gradual rise" of thick seams rather than toward the thickest part of the seam. Use the optional Height Compensation Tool to keep the presser foot level; this helps keep the foot in contact with the fabric, and the fabric in contact with the feed dog.*

# Jeans Hem Sample

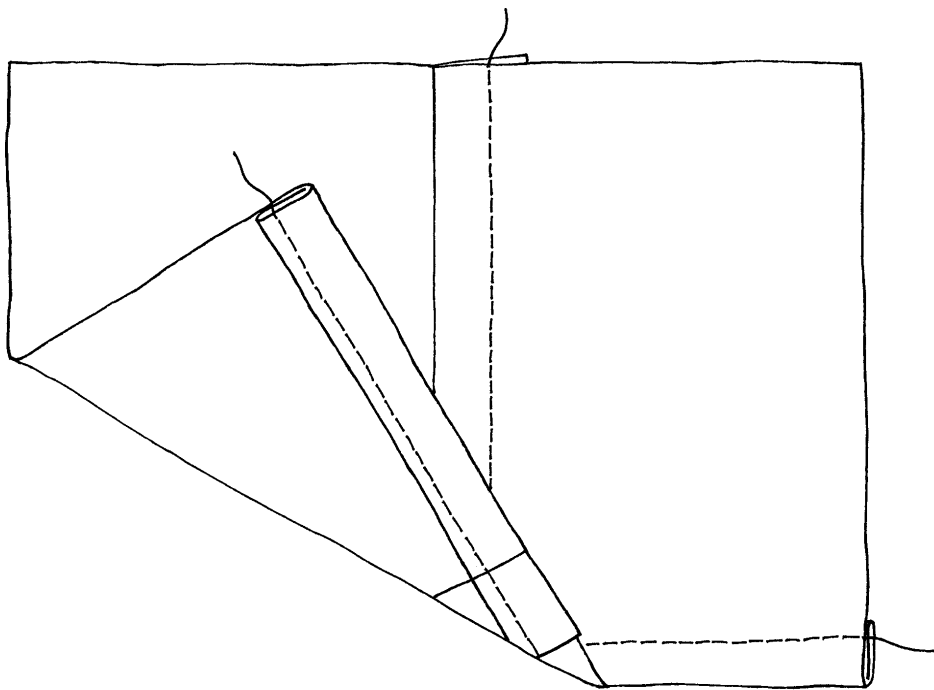

bernette®	<b>55</b>	<b>65</b>	<b>80e</b>	<b>90e</b>
<b>Straight Stitch</b>	2	2	2	2

<b>BERNINA®</b>	<b>1008</b>	<b>220</b>	<b>230PE</b>	<b>240</b>	<b>430</b>	<b>440QE</b>	<b>630</b>	<b>640</b>	<b>200</b>
<b>Straight Stitch</b>	1	1	1	1	1	1	1	1	1



## Shell Edge

Fabric ..... nylon tricot, 6” x 4”  
Stabilizer ..... Aqua Film, 2” x 6”  
Needle ..... 80/12 Universal  
Thread ..... all-purpose  
Presser Foot ..... **BERNINA®** Shell Hemmer Foot #69  
..... **bernette®** Hemmer Foot  
Stitch ..... **BERNINA®** blindstitch (or overlock)  
..... **bernette®** shell hem stitch  
Needle Position ..... as needed

### Notes

#### **BERNINA®**

Select Blindstitch (SW 4mm; leave SL at default setting). Engage Vertical (Left/Right) Mirror Image function if available.

*Alternative: Select the overlock stitch (SW 4mm, SL 3.5 mm).*

*Note: The longer the stitch length, the larger the shells.*

#### **bernette®**

Select the Shell Hem stitch (stitch width = 4mm; leave stitch length at default setting).

Increase/tighten the upper thread tension to 6-8.

Pull on the fabric a bit to see which way the edge curls. Be sure to hem “with the curl” rather than against it.

Place the Aqua Film under the edge of the hem, extending about 2” beyond the back edge of the fabric; baste layers together along the back edge.

Twirl the stabilizer into the scroll of the hemmer foot – the Aqua Film is stiff enough to easily move into the coil. Begin stitching, using the Aqua Film to guide the fabric edge into the coil of the foot.

If necessary, increase/tighten the needle thread tension to create more defined scallops. Remember to return to normal setting after completing this sample.

Trim and mount the sample.

# Shell Edge Sample

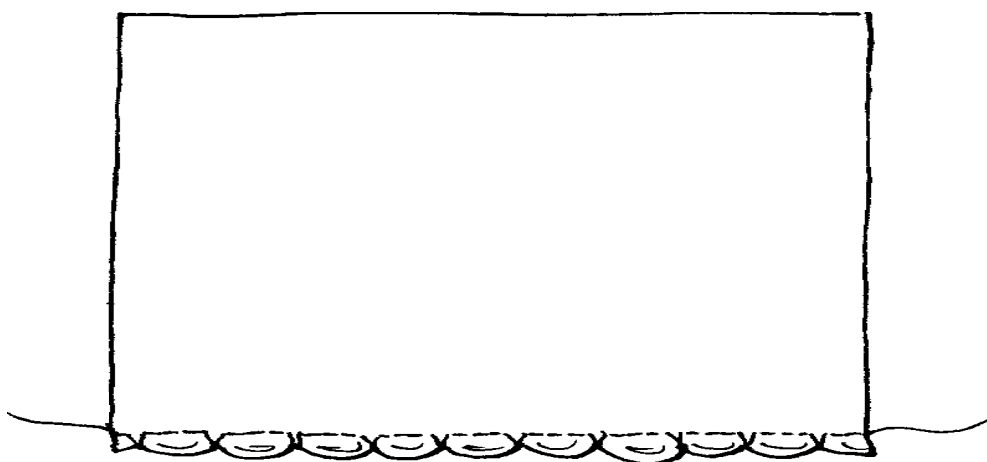

bernette®	<b>55</b>	<b>65</b>	<b>80e</b>	<b>90e</b>
Shell Hem Stitch	6	6	5	5

<b>BERNINA® 1008</b>	<b>220</b>	<b>230PE</b>	<b>240</b>	<b>430</b>	<b>440QE</b>	<b>630</b>	<b>640</b>	<b>200</b>
Blindstitch	3	7	7	7	7	9	9	9

## Rolled and Whipped Edge

Fabric ..... lightweight cotton, 6" x 4"  
Needle ..... 80/12 Universal  
Thread ..... all-purpose  
Presser Foot ..... **BERNINA®** Standard Buttonhole Foot #3/3C  
..... **bernette®** Clear Satin Stitch Foot  
Stitch ..... zigzag  
Needle Position ..... left

Clean one 6" lengthwise edge of "whiskers"

Select the Zigzag Stitch (**BERNINA®** SW = 2.5mm and SL = 1mm or less; **bernette®** SW = 3.5mm and SL = buttonhole setting).

Loosen the top tension if necessary.

### **BERNINA®**

Place cut edge of fabric between the center and left toes of the presser foot and sew.

### **bernette®**

Place cut edge of fabric against the inside of the right toe of the foot and sew.

### Notes:

- The left swing of the needle should be in the fabric, while the right swing falls off of the right edge of the fabric.
- As needle swings left, it should roll fabric into a tiny rolled edge.
- The finer the fabric, the finer the needle and thread used.

Trim and mount the sample.

*This edge finish is used on a single thickness of fine lightweight fabrics. It is also use as a seam finish or as an edge on ruffles, hems, etc.*

## Notes

# Rolled and Whipped Edge Sample

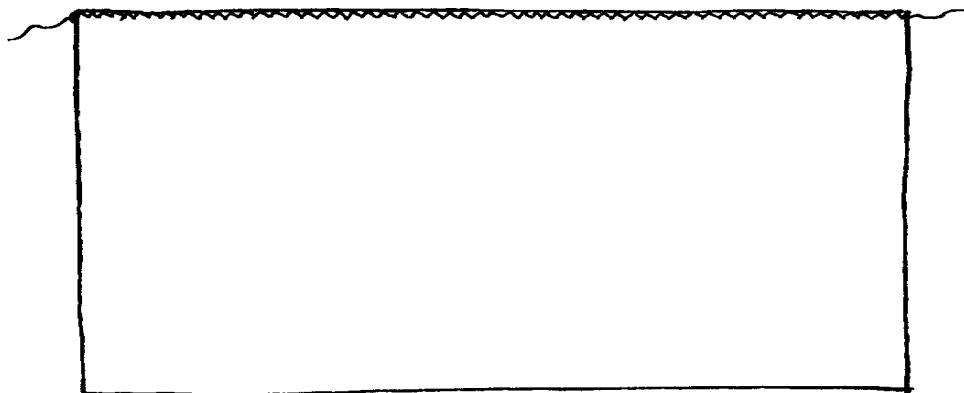

bernette®	<b>55</b>	<b>65</b>	<b>80e</b>	<b>90e</b>
Zigzag Stitch	3	3	3	3

<b>BERNINA®</b>	<b>1008</b>	<b>220</b>	<b>230PE</b>	<b>240</b>	<b>430</b>	<b>440QE</b>	<b>630</b>	<b>640</b>	<b>200</b>
Zigzag Stitch	2	2	2	2	2	2	2	2	2

## Class 2

# Product Reference List

## Practical Stitching

- Feet-ures*, Volumes 1 and 2
- BERNINA® Jeans Foot #8
- BERNINA® Edgestitch Foot #10 *or*
- BERNINA® Edgestitch Foot #10C
- BERNINA® Clear Foot #34 *or*
- BERNINA® Clear Foot #34C
- BERNINA® Shell Hemmer Foot #69
- bernette® Clear Satin Stitch Foot
- bernette® Blind Hem Foot
- bernette® Overcasting Foot
- bernette® Quilting Foot
- bernette® Shell Hem Foot
- Stitch Witchery - 5/8" roll
- Rotary Cutter
- Rotary Cutting Mat
- Clear, Gridded Ruler
- Aqua Film Stabilizer

### Thread

- All-Purpose
- Mettler 60 weight Cotton Embroidery

### Double Needles

- 2.0mm
- 2.5mm
- 3.0mm
- 4.0mm
- 6.0mm (*artista* 640 and 200 only)
- 8.0mm (*artista* 640 and 200 only)

### Jeans Needles

- 90/14
- 100/16
- Double

### Seam Pressing Tools

- BERNINA® Ironing System
- BERNINA® Iron
- Seam Pressing Stick

### Hem Gauges

- Curved Hem Ruler
- 6" Sewing Gauge

# Class 3

## More Practical Stitching

### Class Overview

#### Elastic Samples

- 1 Elastic Edging
- 2 Turned Under Elastic

#### Buttonhole & Eyelet Types & Uses

#### Buttonhole Feet

#### Sizing Buttonholes

#### Buttonhole Samples

- 3 Manual Buttonhole/Corded Buttonhole
- 4 Automatic Buttonhole
- 5 Memory Buttonhole
- 6 Straight Stitch Buttonhole
- 7 Button Sew-On

#### Zipper Samples

- 8 Centered Zipper
- 9 Invisible Zipper

#### Mending

- 10 Darning

This class is formatted for owners of the following models of BERNINA® sewing machines:

- **classic** 1008
- **activa** 220
- **activa** 230PE
- **activa** 240
- **aurora** 430
- **aurora** 440QE
- **artista** 630
- **artista** 640
- **artista** 200

This class is also formatted for owners of the following bernette® sewing machine models:

- 55
- 65
- 80e
- 90e





# Elastic Edging

Fabric ..... nylon tricot, 6" x 4"  
 Notions ..... 9" of elastic lace  
 Needle ..... 80/12 Ballpoint or Stretch  
 Thread ..... all-purpose  
 Presser Foot ..... **BERNINA®** Reverse Pattern Foot #1/1C  
 ..... **bernette®** Zigzag/Universal Foot  
 Stitch ..... running  
 Needle Position ..... center

## Notes

Select the Running stitch (SW = 5mm, SL = 3.5 to 4mm).

**BERNINA®**

Engage the Needle Down function, if available.

**bernette® 80e & 90e**

Engage the Needle Down function after stopping.

Position the elastic wrong side down on the right side of the tricot along one of the 6" edges.

Leave a tail of elastic at the back of the presser foot for a "handle".

Position the elastic so the stitching is at the bottom edge of the elastic lace.

Stretch the elastic lace gently, as it is being sewn.

After stitching, trim the surplus tricot from the wrong side of the elastic lace, close to the stitching.

Mount the sample.

# Elastic Edging Sample

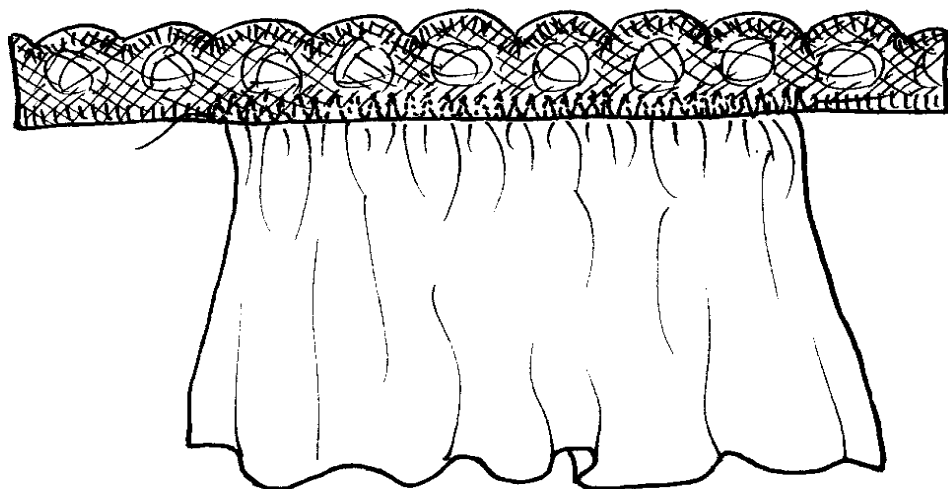

bernette®	55	65	80e	90e
Running Stitch	5	4	4	4
Needle Down/Up Function	--	--	yes	yes

BERNINA®	1008	220	230PE	240	430	440QE	630	640	200
Running Stitch	7	4	4	4	4	4	4	4	4
Needle Down/Up Function	--	yes	yes	yes	yes	yes	yes	yes	yes



# Turned Under Elastic Sample

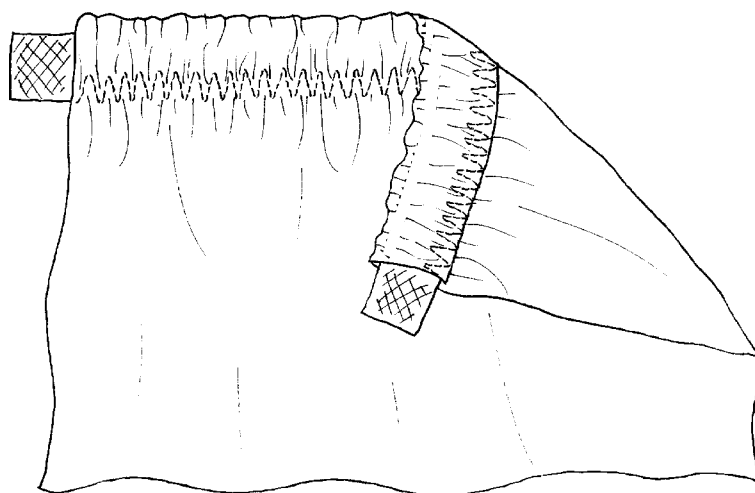

bernette®	55	65	80e	90e
Zigzag Stitch	3	3	3	3
Needle Down/Up	--	--	yes	yes
Overstitch Options	5	4	4	4

BERNINA®	1008	220	230PE	240	430	440QE	630	640	200
Zigzag Stitch	2	2	2	2	2	2	2	2	2
Needle Down/Up	--	yes	yes	yes	yes	yes	yes	yes	yes
Overstitch Options	7	4, 18	4, 21	4, 24, 25	25	27	16	16	16

## Buttonholes & Eyelets Types & Uses

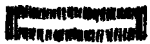
**STANDARD BUTTONHOLE**

Fine to medium weight fabrics. Blouses, shirts, trousers, bed linens.

**HEIRLOOM BUTTONHOLE**

Fine to medium weight fabrics. Blouses, shirts, dresses, trousers, children's and baby clothes, doll clothes, heirloom work.

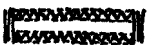
**STRETCH BUTTONHOLE**

All stretch fabrics made from cotton, wool, silk, and synthetic fibers.

**ROUND BUTTONHOLE WITH NORMAL BARTACK**

Medium to heavy weight fabrics of all types. Clothing, jackets, coats, rainwear.

**ROUND BUTTONHOLE WITH HORIZONTAL BARTACK**

Medium to heavy weight fabrics of all types. Clothing, jackets, coats, rainwear.

**KEYHOLE BUTTONHOLE WITH NORMAL BARTACK**

Heavy weight, non-stretch fabrics. Jackets, coats, trousers, leisure wear.

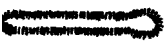
**KEYHOLE BUTTONHOLE WITH POINTED BARTACK**

Non-stretch firm fabric. Jackets, coats, leisure wear.

**KEYHOLE BUTTONHOLE WITH HORIZONTAL BARTACK**

Firm, non-stretch fabrics. jackets, coats, leisure wear.

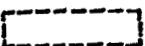
**STRAIGHT STITCH BUTTONHOLE**

For prestitching buttonholes and pocket openings. For bound buttonholes & welt pockets.

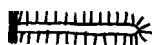
**HAND-LOOK BUTTONHOLE**

For light- to medium-weight woven fabrics. Blouses, dresses, leisure wear, bedding, crafts

**BUTTON SEW-ON PROGRAM**

For flat buttons with 2 and 4 holes. For sewing on snaps, hooks, and charms.

**NARROW ZIGZAG EYELET**

Opening for cords and narrow ribbons/bands, other decorative work.

**STRAIGHT STITCH EYELET**

Opening for cords and narrow ribbons/bands, other decorative work.

## BERNINA® Buttonhole Feet

A number of buttonhole feet are available for BERNINA® sewing machines. The descriptions below will help differentiate between the various feet.

### BUTTONHOLE FOOT #3

The standard 5mm buttonhole foot. Works with any BERNINA® sewing machine.

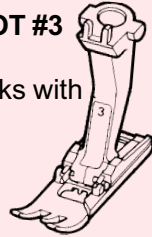

*Included with the 153QE, 165, 185 & 200*

*Snap-on version included with 1008 and 125*

### BUTTONHOLE FOOT #3C

The standard 9mm buttonhole foot. "C" indicates a "coded" foot with a light sensor that allows 9mm wide stitching. For models 1630, *artista* 180, 185 & 200.

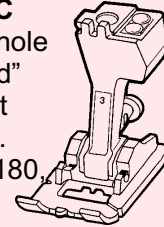

*Included with the artista 640 and 200*

### BUTTONHOLE FOOT WITH SLIDE #3B

5mm foot with a movable slide indicating buttonhole length, making it easy to sew a series of identical buttonholes. For any BERNINA® sewing machine.



### AUTOMATIC BUTTONHOLE FOOT #3C

The automatic buttonhole foot for machines with a 9mm feed system, indicated by the letter "C". Works with models 1630 and *artista* 180.

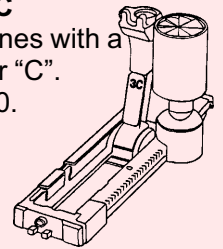

### AUTOMATIC BUTTONHOLE FOOT #3A

Automatic foot for machines with a 5mm and 9mm feed system. "A" indicates an "automatic" foot, with a light sensor for counting stitches. Work with models 1130-1530 and 150-170QE.

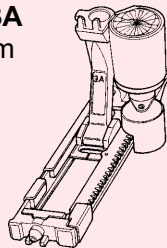

### AUTOMATIC BUTTONHOLE FOOT WITH SLIDE #3A

Combines the handy slide measuring system of Buttonhole Foot #3B with the electronic sensor of the older Automatic Buttonhole Feet #3A and #3C. Works with models 135PE/145 and 150-200.

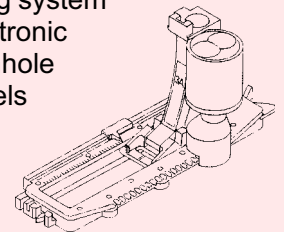

*Included with activa 230 & 240, aurora 430 & 440QE, artista 630, 640, and 200*

## bernette® Buttonhole Feet

### 4-STEP BUTTONHOLE FOOT

5mm foot with a movable slide indicating buttonhole length, making it easy to sew a series of identical buttonholes. For the *bernette*® 55 sewing machine.

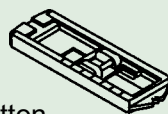

### AUTOMATIC BUTTONHOLE FOOT

The automatic buttonhole foot for the *bernette*® 65, 80e, and 90e sewing machines.

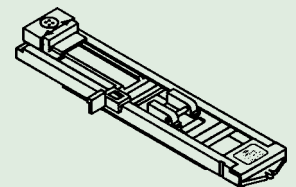



## Manual/Corded Buttonhole

Fabric .....	heavy flannel, 6" x 8"
Stabilizer .....	lightweight tear-away, 4" x 6"
Notions .....	10" of gimp cord
.....	1/2" button
Needle .....	90/14 Universal
Thread .....	30 wt. cotton embroidery, contrasting color
Presser Foot.....	<b>BERNINA®</b> Standard Buttonhole Foot #3/3C
.....	<b>bernette® 55 only:</b> 4-step buttonhole foot
Stitches.....	standard buttonhole, keyhole buttonhole
Needle Position .....	center

Fold the fabric in half to 4" x 6". Press; insert the stabilizer between the layers. Draw a line 1 1/2" from the fold along the 6" length. Draw a 2nd line 1" from 1st line. Mark 3 horizontal lines, between fold and drawn line, spaced about 2" apart.

### **BERNINA®** Standard Buttonhole

Select the standard buttonhole; select the **man** function from the function toolbar, if applicable.

Position the foot over the first short line, aligning the fold of the fabric with the 5/8" marking on the stitch plate, behind the foot.

Sew the first side of the buttonhole, engaging step #1. Stop at the drawn line and select step #2. Continue stitching remaining buttonhole steps.

### **bernette® 55** Standard Buttonhole

Select buttonhole; set SW = 5 and SL = buttonhole.

Position foot over 1st short line, aligning needle with 1 1/2" line.

- Select step 1; sew bartack.
- Select step 2; sew left side of buttonhole, stopping at 2nd long line.
- Select step 3; sew bartack.
- Select step 4; sew right side.

When stitching is complete, remove fabric from under the foot. Bring thread tails to the back and tie off.

### **BERNINA®** & **bernette® 55** Corded Buttonhole

Fold cord in half and loop middle around center "toe" of foot [**bernette® 55** – loop cord at back of foot; lock in front grooves and tie ends in front]. Stitch buttonhole on second line as before, then carefully remove fabric from under foot. Pull ends of cord until loop is pulled up under buttonhole; trim ends of cord. If working on a knit fabric, knot ends of cord together before trimming.

### **BERNINA®** Keyhole Buttonhole

Select keyhole buttonhole if available; select **man** function from function toolbar, if applicable. Place third short line under presser foot as before. Sew keyhole buttonhole on 2nd marked line. Cut 1 buttonhole open. Trim and mount sample.

## Notes

**BERNINA®** Buttonholes  
There are slight variations in the buttonhole stitching sequences on different BERNINA® sewing machine models. On most models, turn the buttonhole knob or press and release the Quick Reverse button to move from one step to the next. See Owner's Manual for detailed instructions for your machine.

# Manual/Corded Buttonhole Sample

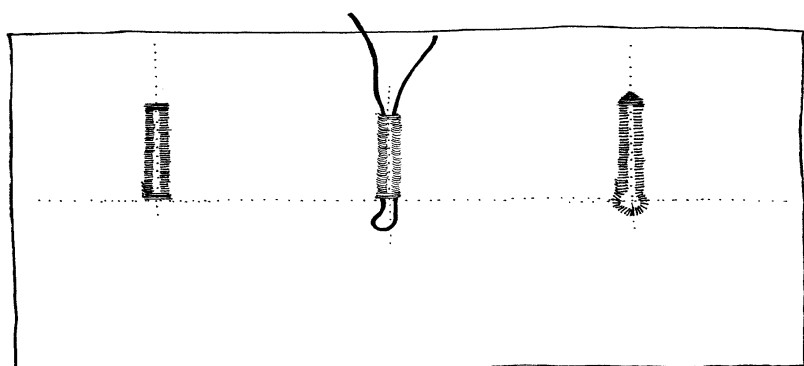

bernette®	55	65	80e	90e
<b>Standard Buttonhole</b>	1	1	1	1
<b>Manual Buttonhole</b>	yes	--	--	--
<b>Auto Buttonhole</b>	--	yes	yes	yes

<b>BERNINA®</b>	<b>1008</b>	<b>220</b>	<b>230PE</b>	<b>240</b>	<b>430</b>	<b>440QE</b>	<b>630</b>	<b>640</b>	<b>200</b>
<b>Standard Buttonhole</b>	dial	10	10	10	10	10	51	51	51
<b>Keyhole Buttonhole</b>	--	11	11	13	13	14	56	56	56
<b>Manual Buttonhole</b>	yes	yes	yes	yes	--	--	yes	yes	yes





## Automatic Buttonhole

Fabric ..... **BERNINA**® cotton interlock, 6" x 8"  
 ..... **BERNINA**® & **bernette**® heavy flannel, 6" x 8"  
 ..... **BERNINA**® fine linen/batiste, 6" x 8" (*aurora* & *artista* only)  
 Stabilizer ..... 3 pieces, 4" x 6" each  
 Needle ..... 90/14 Universal  
 Thread ..... 30 wt. cotton embroidery, contrasting color  
 Presser Foot ..... **BERNINA**® Automatic Buttonhole with Slide #3A  
 ..... **bernette**® automatic buttonhole foot  
 Buttonholes ..... stretch, standard, handlook (*artista* 185 & 200 only)  
 Needle Position ..... center

## Notes

### Preparation

Fold each fabric in half to 4" x 6". Press; insert stabilizer between layers. Draw a line 1½" from the fold along the 6" length. Mark two horizontal lines, running between the fold and the drawn line, about 2" apart.

### BERNINA®

*Note: 1008 & activa 220 do not have an Automatic Buttonhole feature.*

#### Stretch Buttonhole (cotton interlock)

Position foot over the first short line; align fabric fold with 5/8" marking behind foot. Sew buttonhole.

Stop at the horizontal line; press Quick Reverse button – this programs length. Continue sewing – buttonhole is completed automatically.

Sew the programmed buttonhole on the second line.

#### Keyhole Buttonhole (heavy flannel)

Stitch a buttonhole on the first line; sew programmed buttonhole on the second line. *Note: To determine the buttonhole length, calculate bead length only; eye will sew accordingly.*

#### Handlook Buttonhole (linen/batiste) (*aurora* 430/440 & *artista* 630/640/200)

Stitch buttonhole on first line; sew programmed buttonhole on 2nd line.

### bernette® 65/80e/90e

Select the buttonhole; set SW = 5 and SL = buttonhole setting.

#### Automatic Standard Buttonhole

Position the foot over the first short line, aligning the needle (front end of buttonhole) with the long drawn line.

- Open button plate and insert button.
- Lower buttonhole lever and push it toward the back of the machine.
- Stitch buttonhole; the machine will complete buttonhole automatically.

When stitching is complete, remove fabric from under the presser foot. Bring thread tails to back and tie off.

Push lever up when not in use.

#### Corded Automatic Buttonhole

Fold cord in half and loop at back of foot; lock in front grooves and tie ends.

Stitch as above. Tie off as described at the bottom of page 60.

# Automatic Buttonhole Samples

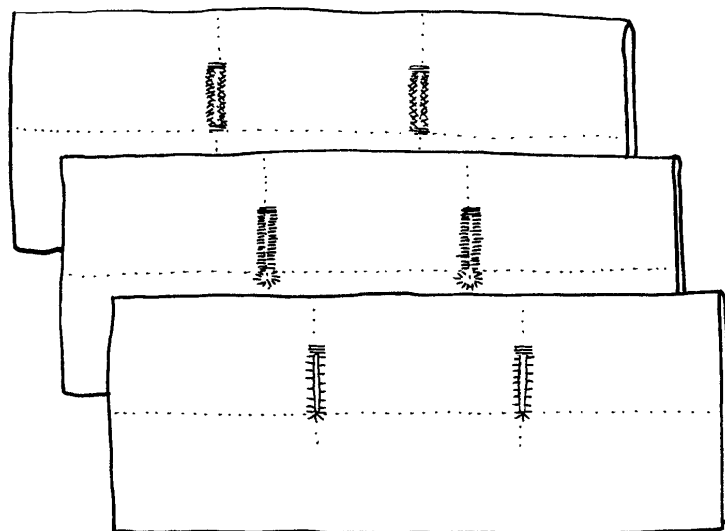

bernette®	55	65	80e	90e
Standard Buttonhole	1	1	1	1
Manual Buttonhole	yes	--	--	--
Auto Buttonhole	--	yes	yes	yes

	<b>BERNINA® 1008</b>	<b>220</b>	<b>230PE</b>	<b>240</b>	<b>430</b>	<b>440QE</b>	<b>630</b>	<b>640</b>	<b>200</b>
Automatic Buttonhole	--	--	yes	yes	yes	yes	yes	yes	yes
Standard Buttonhole	dial	10	10	10	10	10	51	51	51
Handlook Buttonhole	--	--	--	--	15	16	63	63	63
Stretch Buttonhole	--	--	--	12	--	--	53	53	53



**BERNINA®** *models only*

## Memory Buttonhole

Fabric .....	heavy woven, 6" x 8"
Stabilizer .....	lightweight tear-away, 4" x 6"
Needle .....	90/14 Universal
Thread .....	30 wt. cotton embroidery, contrasting color
Presser Foot .....	Automatic Buttonhole with Slide #3A
Stitch .....	standard buttonhole
.....	any other buttonhole
Needle Position .....	center



Fold the fabric in half to 4" x 6". Insert the stabilizer between the fabric layers. Mark 4 lines on the fabric where the buttonholes will be sewn.

### Temporary Buttonhole Memory

Select the Standard Buttonhole; sew a buttonhole of the desired length on the first line.

Sew the programmed buttonhole again on the second line. The machine will remember this length until a new measurement is programmed or until the machine is turned off.

### Long Term Buttonhole Memory

Select any buttonhole; sew a buttonhole of the desired length on the third line.

To save buttonhole in Long Term Memory, touch the appropriate symbol or button for your machine.

Turn machine off, then on again.

Select the same buttonhole; sew it again on the fourth line and compare the size to the previous buttonhole.

# Memory Buttonhole Sample

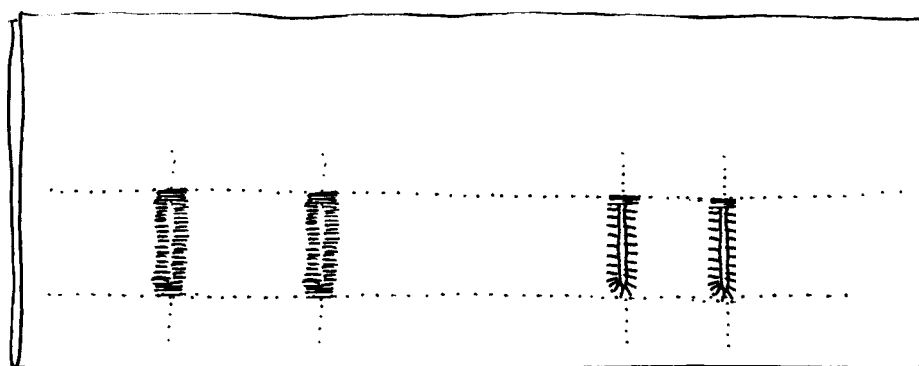

	<b>BERNINA® 1008</b>	<b>220</b>	<b>230PE</b>	<b>240</b>	<b>430</b>	<b>440QE</b>	<b>630</b>	<b>640</b>	<b>200</b>
<b>Standard Buttonhole</b>	dial	10	10	10	10	10	51	51	51
<b>Long Term Memory Buttonhole</b>	--	--	mem←	mem←	mem←	mem←	save	save	save



**BERNINA®** models only

## Straight Stitch Buttonhole

Fabric ..... firm, woven fabric, 4" x 6"  
Stabilizer ..... lightweight tear-away, 4" x 6"  
Needle ..... 90/14 Universal  
Thread ..... 30 wt. cotton embroidery, contrasting color  
Presser Foot ..... Automatic Buttonhole Foot with Slide #3A  
Stitch ..... straight  
Needle Position ..... center

### Notes

Mark two lines perpendicular to the fold, spaced about 2" apart.

Attach Automatic Buttonhole Foot with Slide #3A/3C to machine.

Select the Straight Stitch Buttonhole.

Stitch a buttonhole, positioning the beginning of it on the first line, aligning the fold with the  $\frac{5}{8}$ " marking behind the foot.

Position the needle on the second line. Stitch another straight stitch buttonhole - *do not remove fabric*.

Select the Standard Buttonhole - sew this buttonhole (the same length as the straight stitch buttonhole) directly on top of the straight stitch buttonhole.

#### Notes:

- *Straight stitch buttonholes can be used to pre-sew and reinforce buttonholes on fabrics that fray easily. The buttonhole beads and bartacks will cover the stitching. Any method for determining buttonhole length can be used.*
- *Straight stitch buttonholes can be used as buttonholes on imitation suede and leather.*
- *The distance between the prestitched lines can be adjusted with the stitch width. The stitch length can also be adjusted to suit the fabric.*

# Straight Stitch Buttonhole Sample

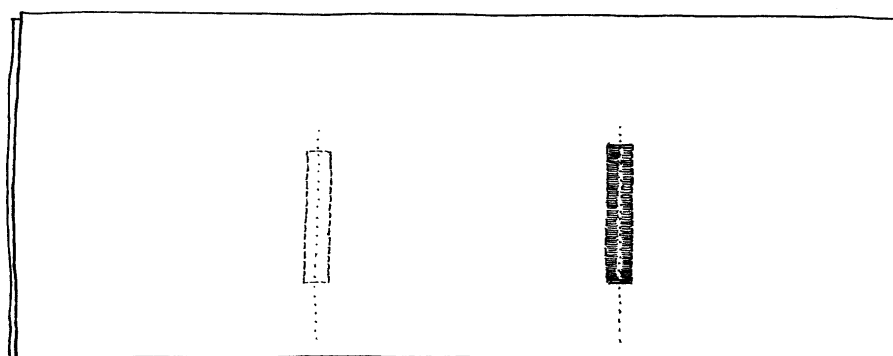

	<b>BERNINA® 1008</b>	<b>220</b>	<b>230PE</b>	<b>240</b>	<b>430</b>	<b>440QE</b>	<b>630</b>	<b>640</b>	<b>200</b>
<b>Straight Stitch Buttonhole</b>	--	--	12	14	14	15	59	59	59
<b>Standard Buttonhole</b>	dial	10	10	10	10	10	51	51	51

# Button Sew-On

- Fabric ..... firm, woven fabric 4" x 6"
- Stabilizer ..... lightweight tear-away, 4" x 6"
- Notions ..... button, charm, hook/eye, 6" of narrow ribbon
- Needle ..... 90/14 Universal
- Thread ..... 30 wt. cotton embroidery, contrasting color
- Presser Foot ..... **BERNINA®** Button Sew-On Foot #18  
 ..... **bernette®** button sew-on foot
- Stitch ..... button sew on program (or universal or zigzag)
- Needle Position ..... center

## Notes

Lower the feed dogs, then attach the button sew-on foot to the machine. Select the button the sew-on stitch. If not available, select the universal or zigzag stitch.

Fold fabric in half to 2" x 6"; press. Insert stabilizer between layers.

### Technique #1 – With Thread Shank

*Optional: Use a glue stick to hold a button in place.*

**BERNINA® only:** Adjust the pin on Button Sew-On Foot #18 to the highest position for a long shank. *Note: A short shank can be made for dresses and blouses or a long shank can be made for heavier fabrics such as coats and blazers.*

All **BERNINA®** & **bernette®** Machines: Check distance between the holes of the button by turning the hand wheel; adjust the stitch width if necessary. Hold the thread tails as you begin to sew.

If using the button sew-on stitch, the machine stops automatically when program is complete; threads are secured as part of the program.

If using the universal or zigzag stitch, sew 6-8 stitches, stop, and tie threads on the wrong side to secure; trim excess thread

### Technique #2 – Without Thread Shank

Using the lowest shank setting and the instructions above, attach a charm, a ribbon, and a hook-and-eye to the same fabric.

Mount the sample.

# Button Sew-On Sample

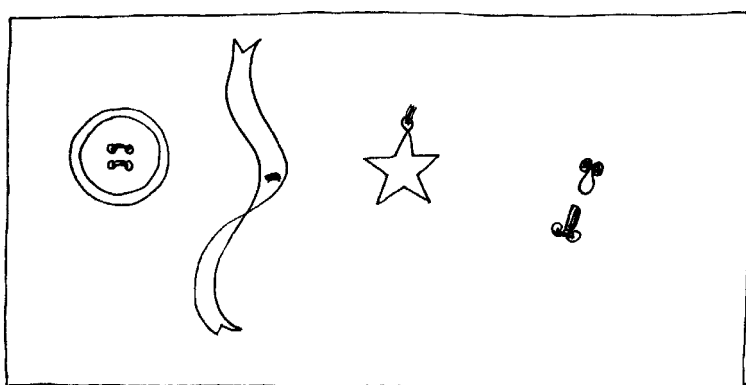

bernette®	55	65	80e	90e
Universal Stitch	--	7	6	6
Zigzag Stitch	3	3	3	3

BERNINA®	1008	220	230PE	240	430	440QE	630	640	200
Button Sew-On Stitch	--	12	13	15	16	17	60	60	60
Universal Stitch	4	17	20	23	24	26	15	15	15
Zigzag Stitch	2	2	2	2	2	2	2	2	2



## Centered Zipper

Fabric .....	two pieces of firm, woven fabric, 6" x 8"
Other .....	9" neckline zipper
Needle .....	90/14 Universal
Thread .....	30 wt. cotton embroidery, contrasting color
Presser Foot.....	<b>BERNINA®</b> Reverse Pattern Foot #1/1C
.....	<b>BERNINA®</b> Zipper Foot #4
.....	<b>BERNINA®</b> Zipper Foot with Guide #14
.....	bernette® zigzag/universal foot
.....	bernette® zipper foot
Stitch .....	straight
Needle Position .....	far left or far right, as indicated
Other .....	Collins Wash-Away Wonder Tape

## Notes

### Attaching the Zipper

Using **BERNINA®** Foot #1/1C or **bernette®** zigzag/universal foot and a straight stitch, sew seam from bottom to where zipper stop will be. Select a basting stitch (see pages 18-19); continue stitching to within 1/2" from top of seam. Change back to a regular length stitch; sew the rest of the way to secure.

Press seam open; place right side of zipper against seam allowance so zipper teeth are centered over the seam. Pin or baste (using Wonder Tape) each side of zipper to *seam allowance only*.

Change to zipper foot; adjust **needle/foot** position to right or left as needed to stitch close to zipper teeth. Sew through *zipper tape and seam allowance only*, from bottom to top on each side. Pin or baste through all layers.

### Topstitching the Zipper

#### **BERNINA®**

Change to Zipper Foot with Guide #14.

*Left Side:* Adjust seam guide 1 notch right of center. Adjust needle position to far left. Sewing from right side of fabric and starting at lower edge, sink needle into the seam. Sew out from zipper stop about 3/8", stop, pivot and make sure seam guide lying in ditch of seam. Sew up left side of zipper.

*Right Side:* Adjust guide one notch to left of center; move needle position to far right. Repeat above steps, starting at seam and sewing to the right.

Mount sample, attaching only at top.

#### bernette®

*Left Side:* Adjust foot to left of center. Sewing from right side of fabric and starting at lower edge, sink needle into the seam. Sew out from zipper stop about 3/8", stop, pivot and make sure the edge of the foot is lying in the ditch of the seam. Sew up left side of zipper.

*Right Side:* Adjust foot to right of center. Repeat above steps, starting at seam and sewing to the right.

Mount sample, attaching only at top.

# Centered Zipper Sample

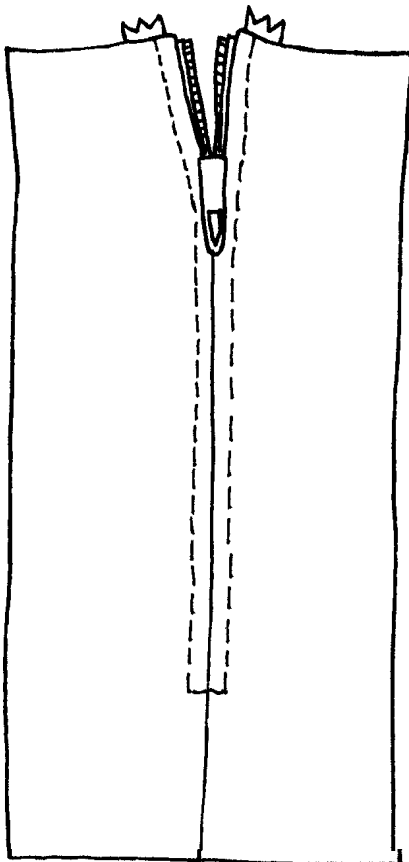

bernette®	55	65	80e	90e
<b>Straight Stitch</b>	2	2	2	2

<b>BERNINA®</b>	1008	220	230PE	240	430	440QE	630	640	200
<b>Straight Stitch</b>	1	1	1	1	1	1	1	1	1
<b>Needle Positions</b>	5	9	9	9	11	11	11	11	11



**BERNINA® models only**

## Invisible Zipper

Fabric .....	two pieces of firm, woven fabric, 6" x 8"
Other .....	9" invisible zipper
Needle .....	90/14 Universal
Thread .....	30 wt. cotton embroidery, contrasting color
Presser Foot.....	Invisible Zipper Foot #35
.....	Bulky Overlock Foot #12/12C
.....	Reverse Pattern Foot #1/1C
Stitch .....	straight
Needle Position .....	as needed

## Notes

*Note: The invisible zipper can be used in place of a conventional zipper when an uninterrupted design line is desired.*

### Zipper Insertion

Mark seam lines on right side of fabric. Select the Straight Stitch. Open zipper. *It is not necessary to press coils as with other invisible zipper applications.* Invisible Zipper Foot #35 has specially designed grooves that guide the zipper coils out of the way as the tape is stitched in place. *Note: Do not sew the seam first as with conventional zippers. Invisible zipper tapes are sewn to fabric sections first, then seam is sewn.*

With right sides together, baste or pin the right zipper tape to the right garment piece, so coil is on the 5/8" seam line.

Using center needle position, place coil in right groove of Foot #35. Sew until foot is stopped by the zipper pull. *Note: Needle should sew close to, but not into, the zipper coils.*

With right sides together, baste or pin the left zipper tape to the left garment piece so that the coil is again on the 5/8" seam line.

Check to be sure the zipper is not twisted. Place the coil in the left groove of the foot and complete as with the right side.

### Completing Seam

Close zipper. Using Bulky Overlock Foot #12 or #12C, place fabric right sides together and stitch as close to the zipper as possible, starting about 1/2" above the bottom of the zipper. It may be necessary to move the needle position to the left slightly. Backstitch to begin and sew about 2"; then change to Foot #1C to complete the seam. Press and trim the sample. Mount it, attaching it only at the top. You can then lift the sample and use it as a reference.

# Invisible Zipper Sample

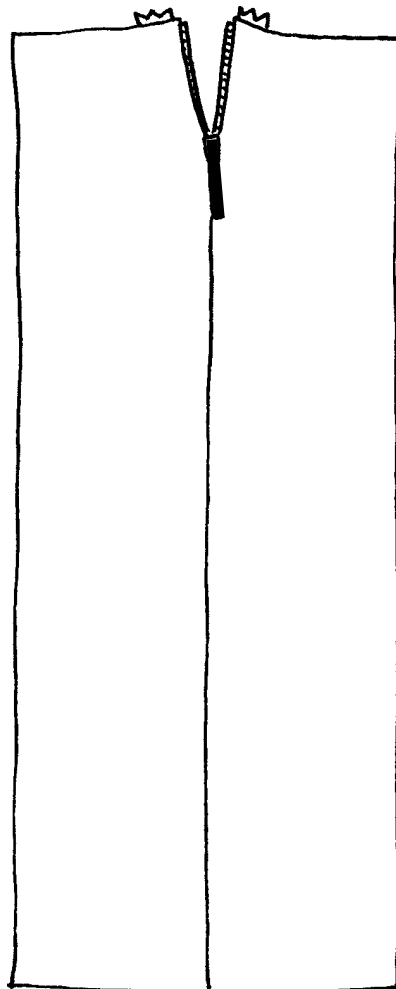

	<b>BERNINA® 1008</b>	<b>220</b>	<b>230PE</b>	<b>240</b>	<b>430</b>	<b>440QE</b>	<b>630</b>	<b>640</b>	<b>200</b>
<b>Straight Stitch</b>	1	1	1	1	1	1	1	1	1



## Darning

Fabric .....	firm, woven fabric 4" x 6"
Interfacing .....	fusible tricot knit interfacing, 3" x 4"
Needle .....	90/14 Universal
Thread .....	30 wt. cotton embroidery, contrasting color
Presser Foot.....	<b>BERNINA®</b> Darning Foot #9
.....	<b>BERNINA®</b> Reverse Pattern Foot #1/1C
.....	<b>BERNINA®</b> Automatic Buttonhole Foot with Slide #3A
.....	bernette® embroidery/darning foot
.....	bernette® satin stitch foot
Stitch .....	straight
.....	simple darning program
.....	reinforced darning program
Needle Position .....	center

## Notes

**Preparation:** Make a ½" hole in the fabric; make 2 tears about 1" each.

### Manual Darning

Attach darning foot to machine. Lower feed dog; select straight stitch. Bond fusible knit interfacing to wrong side of fabric, behind round hole. Hoop fabric to prevent distortion. Stitch, moving the hoop up and down, then side to side without pressure. Raise feed dog when finished.

### BERNINA®

#### Simple Darning

Select the simple darning program, if available, for the first tear. Attach Foot #1/1C. Engage appropriate symbol for your machine.

Sew 1st row the length of tear – press and release Quick Reverse at end of row; length is now programmed. Complete darning program – machine stops automatically.

#### Reinforced Darning

Select Reinforced Darning Program for second tear. Use Foot #3A.

Insert needle to left of top of tear. Begin sewing; notice that running stitch is sewn first.

When length of the tear has been covered, press Quick Reverse. Programming is complete and the machine will finish automatically.

### bernette®

#### Darning with Sewn-Out Zigzag

Select the 3-step zigzag for the first tear. Attach the satin stitch foot to the machine.

Sew first row of stitching the length of the tear, through middle of tear.

Sew a second and third row, overlapping the first row on each side.

Stitch a fourth and fifth row, overlapping the second and third rows on each side.

Continue until entire tear is covered.

# Darning Sample

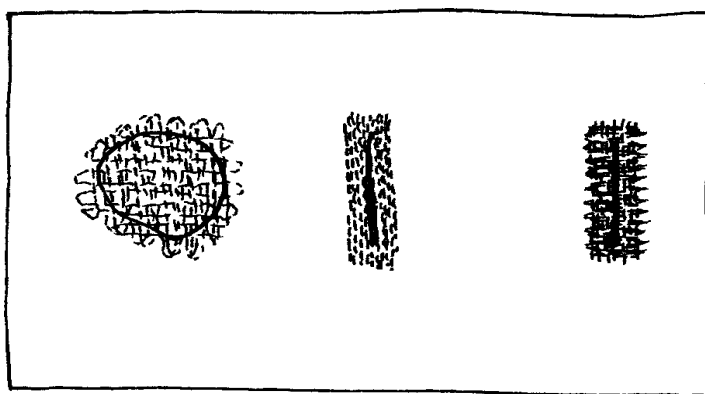

bernette®	55	65	80e	90e
<b>Straight Stitch</b>	2	2	2	2
<b>3-Step Zigzag Stitch</b>	5	4	4	4

<b>BERNINA® 1008</b>	<b>220</b>	<b>230PE</b>	<b>240</b>	<b>430</b>	<b>440QE</b>	<b>630</b>	<b>640</b>	<b>200</b>
<b>Straight Stitch</b>	1	1	1	1	1	1	1	1
<b>Simple Darning Program</b>	--	13	15	17	18	20	22	22
<b>Simple Darning Symbol</b>	--	foot #1 auto	foot #1 auto	foot #1 auto	--	--	foot 3	foot 3
<b>Reinforced Darning Program</b>	--	--	--	--	--	--	23	23
								stitch counter
								23

## Class 3

# Product Reference List

## More Practical Stitching

- Feet-ures, Volumes 1 and 2
- BERNINA® Bulky Overlock Foot #12/12C
- BERNINA® Zipper Foot with Guide #14
- BERNINA® Button Sew-On Foot #18
- BERNINA® Invisible Zipper Foot #35
- bernette® Zipper Foot
- bernette® Embroidery/Darning Foot
- bernette® Satin Stitch Foot
- bernette® Button Sew-On Foot
- bernette® Automatic Buttonhole Foot (65, 80e, 90e)
- bernette® 4-Step Buttonhole Foot (55)
  
- BERNINA® Ironing System
- BERNINA® Iron
  
- Gimp or Pearl Crown Rayon
- Stitch Witchery (narrow roll)
- OESD Tear-Away Stabilizer
- Buttonhole Space Tape
- Buttonhole Placement Gauge
- Marking Pens & Pencils
- Applique Scissors
- Seam Sealant
- Glue Stick
- Buttonhole Cutter & Block Set
- Cotton Elastic

# Class 4

## Decorative Techniques

### Class Overview

#### Gathering Samples

- 1 Gathering Over One Cord
- 2 Gathering Over Two Cords
- 3 Gathering with the Gathering Foot
- 4 Gathering with BERNINA® Ruffler #86

#### Specialty Needle Samples

- 5 Pintucks & Double Needles
- 6 Triple (Drilling) Needle
- 7 Wing Needle/Double Wing Needle
- 8 Entredoux

This class is formatted for owners of the following models of BERNINA® sewing machines:

- **classic** 1008
- **activa** 220
- **activa** 230PE
- **activa** 240
- **aurora** 430
- **aurora** 440QE
- **artista** 630
- **artista** 640
- **artista** 200

This class is also formatted for owners of the following bernette® sewing machine models:

- 55
- 65
- 80e
- 90e





# Gathering Over One Cord

Fabric ..... medium weight cotton, 12" x 4"  
 Notions ..... 18" of cord  
 Needle ..... 80/12 Universal  
 Thread ..... all-purpose  
 Presser Foot ..... **BERNINA®** Embroidery Foot #6 **or**  
 ..... **BERNINA®** Clear Foot #39  
 ..... **bernette®** cording foot  
 Stitch ..... zigzag  
 Needle Position ..... center

## Notes

Trim all four edges of sample fabric before beginning.

**BERNINA®**

Thread cord through the hole in Foot #6 OR #39, leaving a 2"-3" tail behind the foot.

**bernette®**

Thread cord through center groove of cording foot, leaving a 2"-3" tail behind the foot.

Select the zigzag stitch and set SW = 2.5mm and SL = 2-2.5mm.

Stitch <sup>5</sup>/<sub>8</sub>" from one 12" edge; sew over the cord.

Secure the cord at the beginning and then pull it to gather the sample to 6".

*Notes:*

- *Gathering over cord adds additional strength, eliminates thread breakage and allows better control of gathering.*
- *Drop the feed dog and sew a bartack at the beginning and end of cord for strength.*
- *Do not sew through cording.*

# Gathering Over One Cord Sample

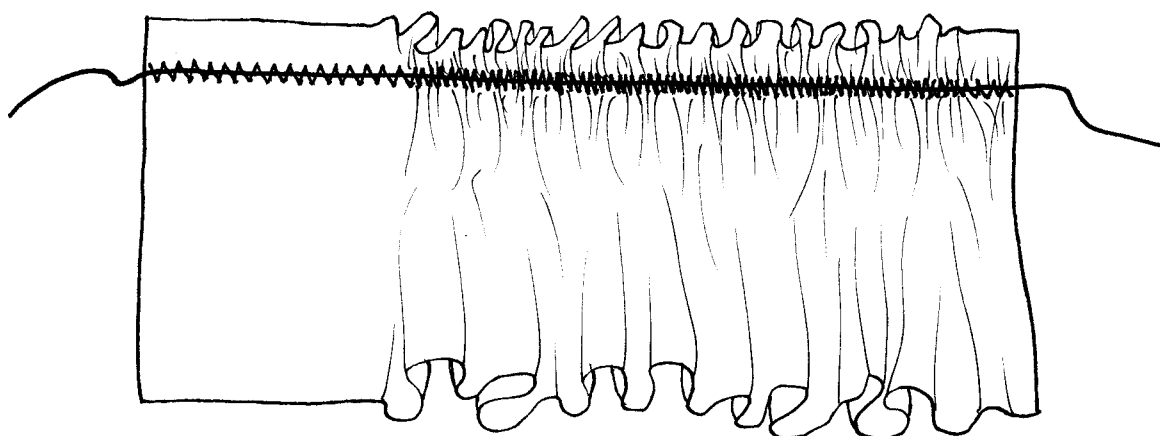

bernette®	<b>55</b>	<b>65</b>	<b>80e</b>	<b>90e</b>
Zigzag Stitch	3	3	3	3

<b>BERNINA®</b>	<b>1008</b>	<b>220</b>	<b>230PE</b>	<b>240</b>	<b>430</b>	<b>440QE</b>	<b>630</b>	<b>640</b>	<b>200</b>
Zigzag Stitch	2	2	2	2	2	2	2	2	2



# Gathering Over Two Cords Sample

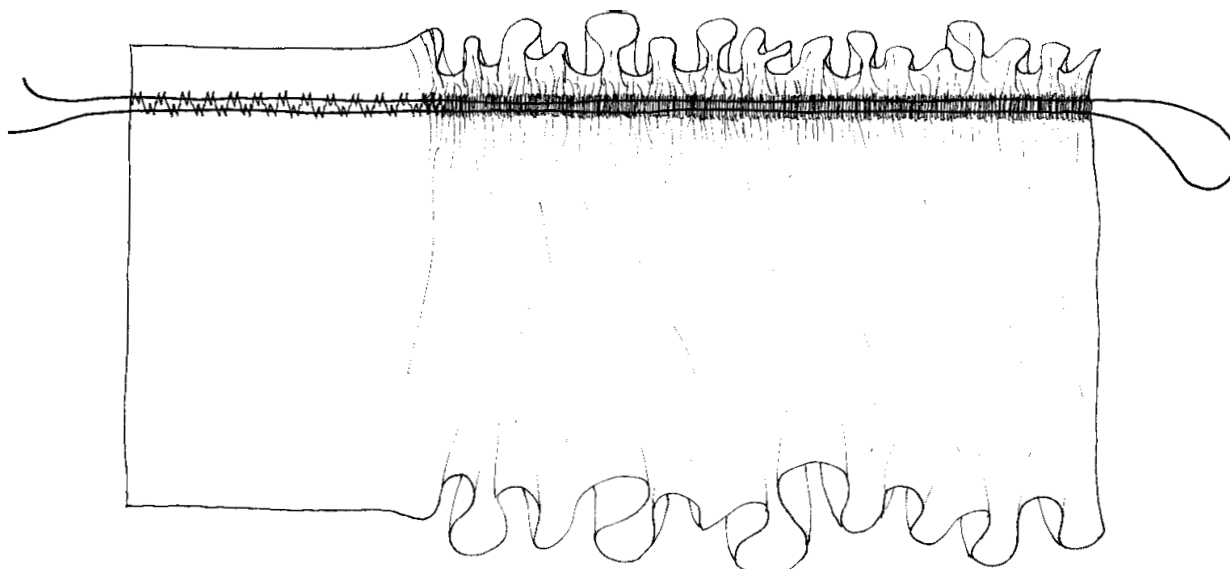

bernette®	55	65	80e	90e
Rampart Stitch	--	--	8	8

<b>BERNINA®</b> 1008	220	230PE	240	430	440QE	630	640	200	
Gathering Stitch	--	14	16	18	19	20	12	12	12

# Gathering with the Gathering Foot

Fabric .. 2 pieces medium weight cotton, one 4" x 6", one 4" x 12"  
 Needle ..... 80/12 Universal  
 Thread ..... all-purpose  
 Presser Foot ..... **BERNINA®** Wide Gathering Foot #16 **or**  
 ..... **BERNINA®** Extra-wide Gathering Foot #16  
 ..... **bernette®** gathering foot  
 Stitch ..... straight  
 Needle Position ..... as indicated

## Notes

**BERNINA®**

Attach the gathering foot to the machine.

Select the straight stitch; adjust stitch length to 5mm; set needle position to the far left.

**bernette®**

Remove presser foot holder and attach gathering foot to machine.

Select the straight stitch; adjust length to 5mm; set needle position to center. Tighten upper thread tension to 7.

Trim all four edges of the sample fabrics before beginning.

Place 12" length of fabric right side up under foot. Align edge of fabric with <sup>5</sup>/<sub>8</sub>" mark on the stitch plate. Stitch for 2" to 3"; stop.

Insert the 6" length of fabric right side down into the slot of the foot, with the raw edge against the right side of the foot.

Continue stitching, carefully guiding both pieces of fabric. Guide fabric that is being gathered with the left hand, flat fabric with the right hand. Note that fabric being gathered moves under the foot much faster than the flat, top layer.

Trim and mount sample.

*Notes: There are three things that effect the amount of gathers:*

1. *Fabric Weight - The lighter weight the fabric, the easier to gather.*
2. *Tension - Increased upper tension increases the amount of gathering.*
3. *Stitch Length - The longer the stitch length, the tighter the gathers.*

*Use the basting stitch or the Long Stitch function to increase gathers in heavier weight fabrics such as woolens and corduroys.*

# Gathering with the Gathering Foot Sample

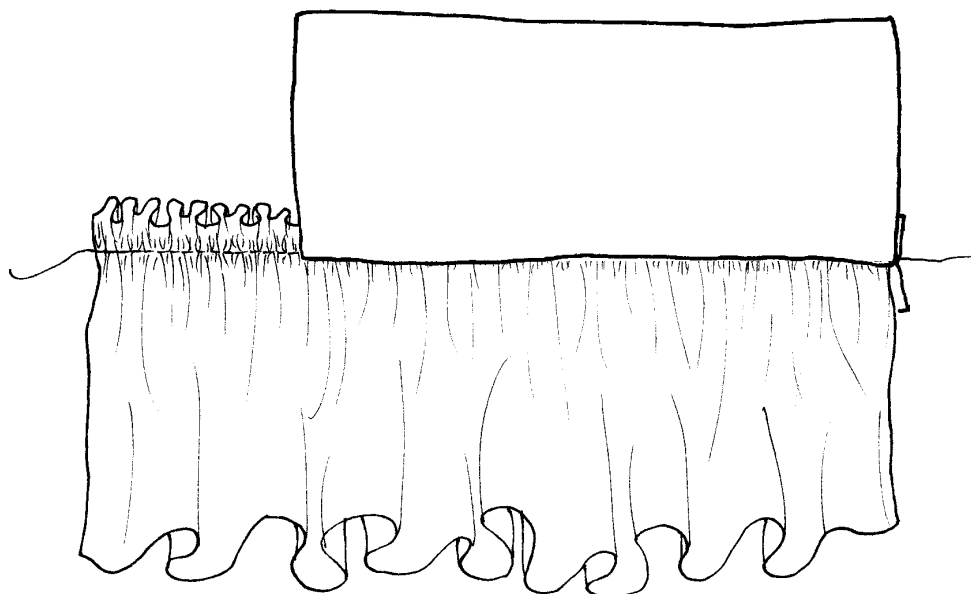

bernette®	55	65	80e	90e
<b>Straight Stitch</b>	2	2	2	2

<b>BERNINA® 1008</b>	<b>220</b>	<b>230PE</b>	<b>240</b>	<b>430</b>	<b>440QE</b>	<b>630</b>	<b>640</b>	<b>200</b>
<b>Straight Stitch</b>	1	1	1	1	1	1	1	1

## Gathering with **BERNINA®** Ruffler #86

Fabric .. 2 pieces medium weight cotton, one 4" x 6", one 4" x 18"  
Needle ..... 80/12 Universal  
Thread ..... all-purpose  
Presser Foot ..... **BERNINA®** Ruffler Attachment #86  
Stitch ..... straight  
Needle Position ..... center

### Notes

**BERNINA®**

Attach Ruffler Attachment #86 to the machine.

**bernette®**

Remove the presser foot holder from the machine.

Remove the **BERNINA®** adapter from Ruffler Attachment #86.

Attach the Ruffler to the machine.

Trim fabric edges with wavy rotary cutter before sewing.

Select Straight Stitch (SW = 0mm, SL= 1mm to 5mm). The longer the stitch length, the deeper the pleats will be.

Set the adjustment lever on the attachment at 1.

Place the 18" length of fabric (the piece to be ruffled) wrong side up between the two blades, snugging it against the edge of the seam guide slot, making sure it is slightly beyond the needle.

Lower the foot and begin sewing; stitch for 2" to 3". If gathers are too deep, turn the adjusting screw counter clockwise; if too shallow, turn the screw clockwise.

# Gathering with **BERNINA®** Ruffler #86 Sample

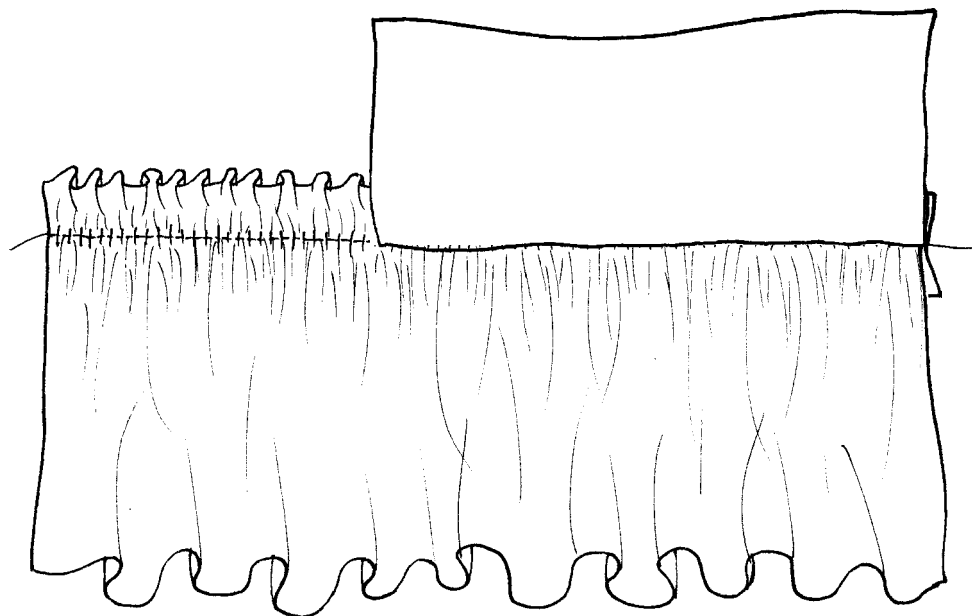

bernette®	55	65	80e	90e
<b>Straight Stitch</b>	2	2	2	2

<b>BERNINA®</b>	1008	220	230PE	240	430	440QE	630	640	200
<b>Straight Stitch</b>	1	1	1	1	1	1	1	1	1





## Pintucks & Double Needles

Fabric ..... lightweight cotton, 6" x 8", starched  
 Needle ..... Double (size should correspond to foot/machine\*)  
 Thread ..... two spools, all-purpose  
 Miscellaneous ..... gimp cord or other colorfast, shrink-proof cord  
 Presser Foot..... **BERNINA®** Pintuck Foot #30, #31, #32, or #33  
 ..... **bernette®** satin stitch foot  
 Stitches..... straight, various decorative stitches as desired  
 Needle Position ..... center

### BERNINA®

Insert the Double needle and thread with 2 different colors.

Select straight stitch; adjust length to 1.75mm-2mm. Engage Double Needle Limitation function or Security Program if available and select appropriate Double Needle option.

### Parallel Pintucks

Start sewing in one corner and meander across fabric. Sew 5-6 more rows, evenly spaced across one corner of fabric. Position the previously sewn tuck in the groove of the foot.

### Corded Pintucks

Thread machine, using the same thread in both needles and the bobbin.  
**BERNINA® only:** Thread cord through the hole in the needle plate.

It is not possible, with a double needle, to turn completely around a corner in one step. To turn corners, use the following steps:

**bernette® only:** Remove accessory table; use center needle position

- Sew to corner; needle in fabric, drop feed dogs.
- Turn 45°, take 1 stitch, lower needles into fabric, turn another 45°.
- Raise feed dogs and continue.

Sew four random corners.

Sew 2 points as on a leaf or star.

- Sew to corner; needle up.
- Pivot work carefully and lower needles back into same place.

### Decorative Pintucks

Select desired decorative stitches; stitch several rows of pintucks.

### bernette®

Insert the Double needle and thread with 2 different colors. Use the auxiliary spool pin for the second spool and skip the thread guide just above the needle

Select the straight stitch; adjust length to 1.75mm-2mm. Adjust needle position to maximum stitch width – see chart at right.

### Parallel Pintucks

Start sewing in one corner and meander across fabric. Sew 5-6 more rows evenly spaced across corner of the fabric. Position previous tuck against edge of foot

## Notes

### Tips

*Sew at a slower speed and test movement of the needle, making sure that it doesn't hit the presser foot.*

*Tighten top tension to create more dimension.*

\* Choose the correct needle:

- **BERNINA®** Pintuck Foot #30  
3 groove: 4mm needle
- **BERNINA®** Pintuck Foot #31  
5 groove: 2.5 **or** 3mm needle
- **BERNINA®** Pintuck Foot #32  
7 groove: 2mm needle
- **BERNINA®** Pintuck Foot #33  
9 groove: 1.6 needle
- **bernette® 55**  
satin stitch foot  
2.0 needle = 2.5mm max SW  
3.0 needle = 2mm max SW
- **bernette® 65, 80e, 90e**  
satin stitch foot  
2.0 needle = 4mm max SW  
3.0 needle = 4mm max SW

# Pintucks & Double Needles Sample

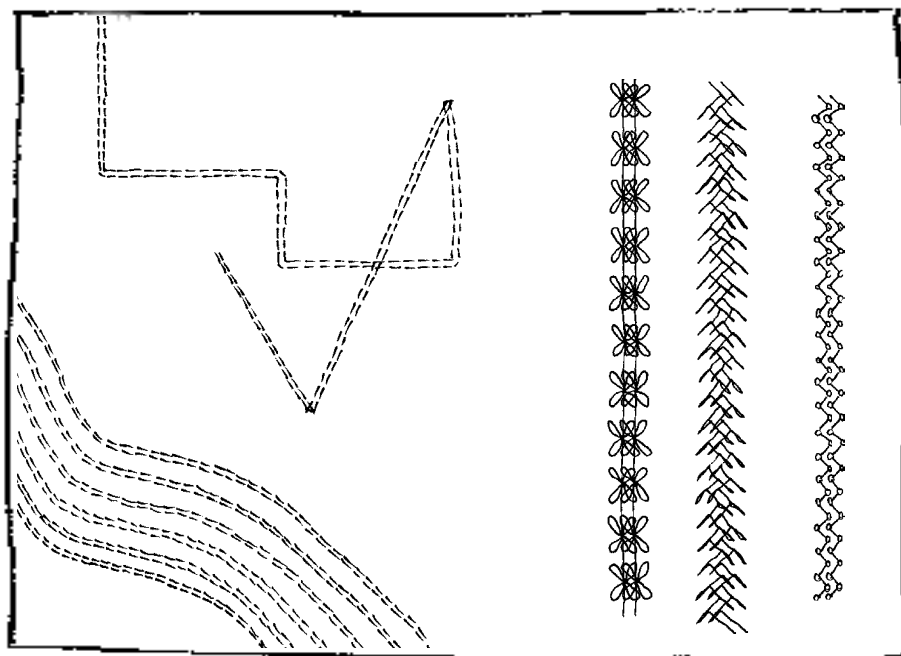

bernette®	55	65	80e	90e
Scallop Stitch	12	8	11	12
Square Stitch	13	9	10	11
Decorative Stitch	--	--	9	10

BERNINA®	1008	220	230PE	240	430	440QE	630	640	200
Feather Stitch	--	45	28	44	53	48	332	332	332
Running Stitch	7	4	4	4	4	4	4	4	4
Straight Stitch Scallop	--	--	--	--	--	160	719	719	719



# Triple (Drilling) Needle

Fabric .....	firmly woven, 6" x 8"
Stabilizer .....	firm tear-away or cut-away, 6" x 8"
Needle .....	Triple (3.0mm)
Thread .....	Isacord embroidery thread, 3 different colors
Presser Foot .....	<b>BERNINA®</b> Clear Foot #34/#34C <i>or</i> ..... <b>BERNINA®</b> Open Embroidery Foot #20/#20C ..... <b>bernette®</b> satin stitch foot
Stitch .....	straight ..... various decorative stitches as desired
Needle Position .....	center

## Notes

Thread each needle with a different color thread. (**bernette®** use the auxiliary spool pin and a supplementary thread stand.)

Engage the Double Needle Limitation or Security Program, if available, and select the appropriate width option.

*Note: If these features are not available, check to be sure the needles will not strike the foot by turning the handwheel to “walk” the machine through the first stitch.*

Select 5 different stitches and sew across the fabric randomly.

When doing decorative needle work you must sew slowly – change motor to ½ speed if this option is available.

Trim threads, then trim sample edges, and mount.

**Tips**  
 Sew at a slower speed and test the movement of the needle, making sure that it doesn't hit the presser foot.  
 Tighten top tension to create more dimension.

# Triple (Drilling) Needle Sample

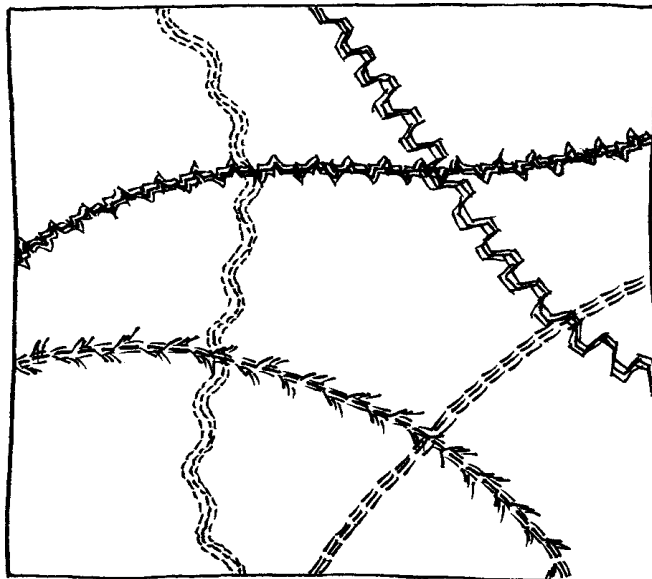

bernette®	50	65	80e	90e
Decorative Stitch Option	4	4	4	4
Decorative Stitch Option	--	7	7	7
Decorative Stitch Option	--	--	26	28

<b>BERNINA® 1008</b>	<b>220</b>	<b>230PE</b>	<b>240</b>	<b>430</b>	<b>440QE</b>	<b>630</b>	<b>640</b>	<b>200</b>	
Decorative Stitch Option	3	45	28	44	53	48	332	332	332
Decorative Stitch Option	7	4	68	95	25	27	16	16	16
Decorative Stitch Option	13	14	16	18	21	22	12	12	12



# Wing Needle/Double Wing Needle

Fabric ..... cotton organdy, 6" x 8"  
 Notions ..... 6" length of heirloom insertion lace  
 Needle ..... Wing size 100/16  
 ..... Double Wing  
 Thread ..... two spools embroidery thread or 60 weight cotton  
 Presser Foot..... **BERNINA®** Clear Foot #34/#34C **or**  
 ..... **BERNINA®** Open Embroidery Foot #20/#20C  
 ..... **bernette®** clear satin stitch foot  
 Stitch ..... straight, blindstitch, decorative stitches as desired  
 Needle Position ..... center

## Notes

### Single Wing Needle

Insert Wing needle. If available, engage the Wing Needle Limitation function or Security Program (Wing needle option). This alters the stitch width so that the “wings” of the needle will not hit the stitch plate; also constrains stitches to the center needle position.

Position lace on top of organdy. Select pin stitch or blanket stitch (if not available, select a narrow zigzag stitch with SW = 2mm). Stitch along one edge of lace, the Mirror Image function if necessary and available. Sew along remaining edge, again engaging Mirror Image – or turning fabric – as needed. Carefully trim fabric from under lace.

Frame lace insertion with three of the stitches suggested in the chart.

### Double Wing Needle

Insert Double Wing needle. Select straight stitch. Engage Double Wing Needle Limitation/Security function if available. Adjust stitch length to 3mm. Stitch across the fabric on the bias (diagonal). At end, carefully pivot and sew back along first line of stitching, with “wing” portion of Double needle entering holes created by the first line of stitching.

Frame center row with two additional lines of stitching:

- 1st row - blindstitch - sew in one direction, pivot, and stitch back to create a “chain” effect
- 2nd row - decorative straight stitch motif, such as a scallop

Carefully remove the stabilizer following the manufacturer’s directions.

Trim and mount the sample.

**Wing Needle Tips:**  
 When selecting stitches to use with a Wing or Double Wing Needle, look for multi-motion stitches where the needle enters the same hole multiple times.  
  
 Stitching on the diagonal (bias) of the fabric allows holes created by the Wing needle to open more easily. To help support fabric and stitching, temporarily bond a layer of heavy, water-soluble stabilizer to wrong side of fabric using a temporary spray adhesive.

# Wing Needle/Double Wing Needle Sample

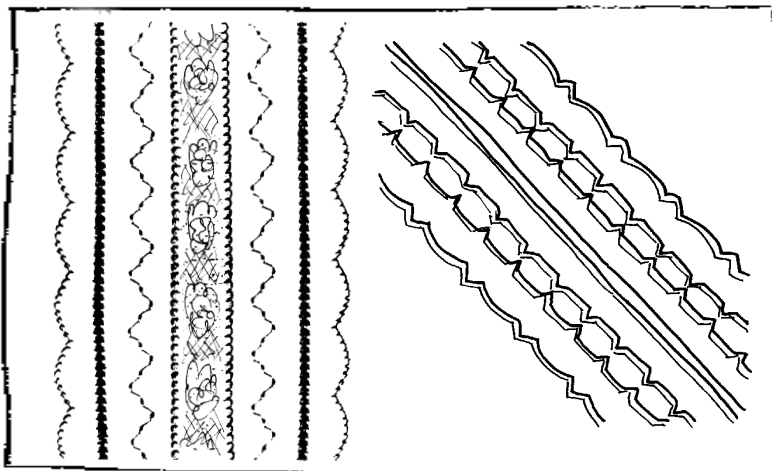

bernette®	55	65	80e	90e
Wing	9	10	S10	S11
Needle	10	11	S8	S8
Stitch	11	12	S4	S4
Options				
Double Wing	2	2	2	2
Needle	9	12	S4	S4
Stitch	6	6	5	5
Options	--	--	S8	S8
	--	--	8	8

BERNINA® 1008	220	230PE	240	430	440QE	630	640	200	
Wing	2	28	25	41	50/132	45/161	720/329	720/329	720/329
Needle	7	4	4	4	4	4	726	726	726
Stitch	4	41	59	76	118	147	701	701	701
Options	--	14	16	18	141	171	732	732	732
Double Wing	1	1	1	1	1	1	1	1	1
Needle	3	7	7	7	7	7	9	9	9
Stitch	4	14	16	18	141	171	719	719	733
Options									
Specialty	--	--	--	--	--	--	security	security	security
Needle Function									



BERNINA® models only

## Entredeux

Fabric ..... cotton organdy, 8" x 6"  
Notions ..... heavy cotton thread for cording  
Stabilizer ..... spray starch and/or water soluble stabilizer  
Needle ..... Wing, size 100  
Thread ..... 60 weight cotton  
Presser Foot ..... **BERNINA®** Cording Foot #25  
Stitch ..... straight  
Needle Position ..... center

## Notes

Insert Wing needle. If available, engage the Security Program, selecting the Wing needle option. This alters the stitch width so that the “wings” of the needle will not hit the stitch plate; also constrains stitches to the center needle position.

Select the entredoux or star stitch; adjust stitch length to 3mm.

Attach Cording Foot #25, but *do not* load cord into the guides at this time. Stitch a row of entredoux.

Load Cording Foot #25 with lengths of heavy cotton thread in grooves 2 and 4.

Stitch a second row of entredoux. As the hemstitching is sewn, the heavy cotton threads fill the outer edges of the stitching, creating a stitch that looks very similar to fine, purchased entredoux.

Trim and mount sample.

# Entreduex Sample

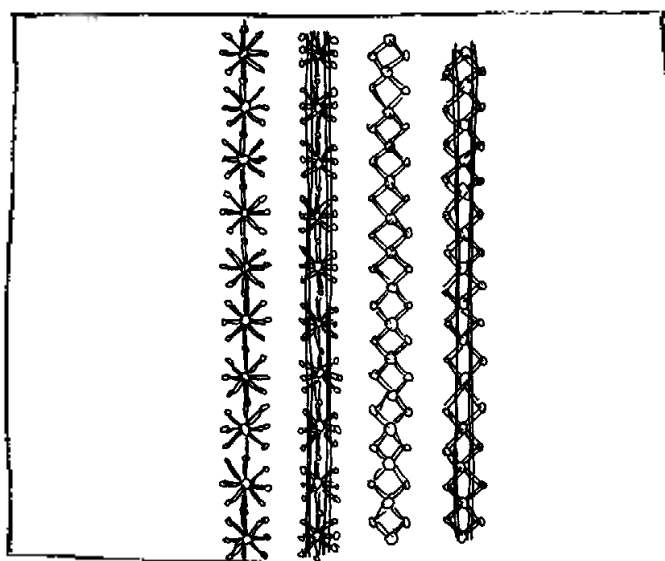

	<b>BERNINA® 1008</b>	<b>220</b>	<b>230PE</b>	<b>240</b>	<b>430</b>	<b>440QE</b>	<b>630</b>	<b>640</b>	<b>200</b>
<b>Star/Pattern Stitch</b>	--	44	64	84	126	155	711	711	711
<b>Entreduex Stitch</b>	--	41	59	76	118	147	701	701	701



## Class 4

# Product Reference List

## Decorative Techniques

- Feet-ures*, Volumes 1 and 2
  - Embroidery Foot #6
  - Edgestitch Foot #10 *or*
  - Edgestitch Foot #10C
  - Bulky Overlock Foot #12 *or*
  - Bulky Overlock Foot #12C
  - Wide Gathering Foot #16 *or*
  - Extra Wide Gathering Foot #16
  - Pintuck Feet
    - #30 - 3 groove
    - #31 - 5 groove
    - #32 - 7 groove
    - #33 - 9 groove
  - Clear Embroidery Foot #39
  - Ruffler Attachment #86
  - bernette® Cording Foot
  - bernette® Gathering Foot
  - bernette® Satin Stitch Foot
- 
- BERNINA® Ironing System
  - BERNINA® Iron

### Needles

- Double Needles
- Triple (or Drilling) Needles
- Wing Needle
- Double Wing Needle

- Guide Bar Set with Rulers
  - Secondary Bobbin Case (Black Latch)
  - Wavy Rotary Cutter
  - Ruler
  - Cutting Mat
- 
- Elastic Thread
  - Gimp Cord
  - Spray Sizing

# Class 5

## More Decorative Techniques

### Class Overview

#### Decorative Detail Samples

- 1 Pleats and Tucks
- 2 Off-the-Edge Scallops
- 3 Lace Insertion
- 4 Fagoting and Bundling
- 5 Fringing
- 6 Piping

#### Embellishment Samples

- 7 Patchwork/Quilting
- 8 Applique
- 9 Surface Embellishment
  - Crazy Patchwork
  - Decorative Stitching
  - Bobbinwork
  - Couching

This class is formatted for owners of the following models of BERNINA® sewing machines:

- **classic** 1008
- **activa** 220
- **activa** 230PE
- **activa** 240
- **aurora** 430
- **aurora** 440QE
- **artista** 630
- **artista** 640
- **artista** 200

This class is also formatted for owners of the following bernette® sewing machine models:

- 55
- 65
- 80e
- 90e

## Pleats and Tucks

Fabric ..... medium weight cotton, 4" x 18"  
 Needle ..... 80/12 Universal  
 Thread ..... all-purpose sewing thread  
 Presser Foot ..... **BERNINA®** Clear Foot #34/34C  
 ..... **BERNINA®** Edgestitch #10/10C  
 ..... **bernette®** zigzag/universal foot  
 ..... **bernette®** blindhem foot  
 Stitch ..... straight  
 Needle Position ..... as directed

### Notes

#### **BERNINA®** Clear Foot #34/34C or **bernette®** zigzag/universal foot

Mark fabric as shown; fold fabric along lines; press.

Fold fabric on 1st line. Stitch 1st tuck, aligning right edge of foot with fold.

Fold fabric along second line. Move needle position to the far left; stitch tuck, aligning fold with the right edge of the foot.

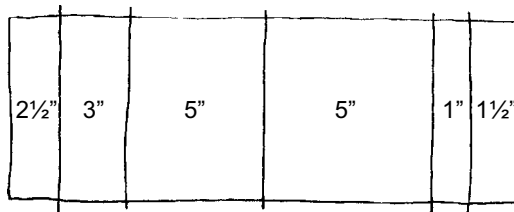

Attach seam guide to back of foot. Adjust guide to 2 1/4" from center needle position. Fold fabric on 3rd line; stitch a 3rd tuck, aligning guide along fold.

#### **BERNINA®**

##### **Edgestitch Foot #10/10C**

Fold fabric along fourth line. Place fold to the left of the center blade of Foot #10/10C, with the fold against the blade.

Move needle position all the way to the left; sew.

Fold fabric along fifth line; position fabric as for the last fold.

Move needle position to "half left" position; sew.

*Note: Very narrow tucks are easily stitched with this foot by adjusting the needle position.*

#### **bernette®**

##### **blindhem foot**

Move white blade to right until it is aligned with the right side of the needle opening.

Fold fabric along fourth line. Place fold to the left of guide, with fold against guide. Sew.

Fold fabric along fifth line; position fabric as for the last fold.

Move white guide halfway back to center; sew.

*Note: Very narrow tucks are easily stitched with this foot by repositioning the white guide.*

# Pleats and Tucks Sample

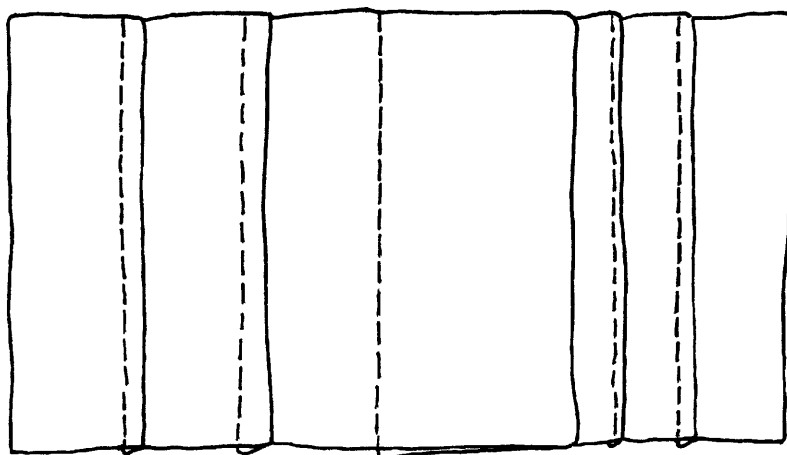

bernette®	55	65	80e	90e
<b>Straight Stitch</b>	2	2	2	2

<b>BERNINA®</b>	1008	220	230PE	240	430	440QE	630	640	200
<b>Straight Stitch</b>	1	1	1	1	1	1	1	1	1
<b>Needle Positions</b>	5	9	9	9	11	11	11	11	11



**BERNINA®** *models only*

# Off-the-Edge Scallops

- Fabric ..... medium weight cotton, 12" x 4"
- Notions ..... cording (gimp, perle cotton)  
 ..... Stitch N Ditch™ Heirloom Stabilizer, 1 yard
- Needle ..... 80/12 Universal
- Thread ..... #75/11 Embroidery
- Presser Foot ..... **BERNINA®** Patchwork Foot #37 **or**  
 ..... **BERNINA®** Patchwork Foot with Guide #57  
 ..... **BERNINA®** Open Embroidery Foot #20/#20C
- Stitch ..... straight
- Needle Position ..... center

## Notes

Draw 4 lines about 1½" apart across the width of the fabric. Fold along each line and press.

Select the Straight Stitch; attach Patchwork Foot #37 to machine. Sew a ¼" tuck on each of the folds.

Change to Open Embroidery Foot #20 or #20C.

Select the Satin Scallop Stitch. Thread the cord through the hole in the stitch plate (directly in front of the needle).

Lay the edge of the Stitch N Ditch™ under the previously sewn tuck, with most of the paper showing beyond the fold of the tuck.

Begin stitching on the paper; cord will be drawn into the scallop stitching. (The scallop actually forms over the cord.) Continue stitching, guiding the fabric under the foot so that only 2-3 stitches at the "V" of the scallop stitch into the fold.

Sew off-the-edge scallops to each of the stitched tucks.

Gently remove Stitch N Ditch™ from completed scallops.

Trim and mount the sample.

**Off the Edge Tip:**  
 Stitch N Ditch™ Heirloom Stabilizer is very thin, crisp, and easy to tear, which makes it perfect for off-the-edge techniques.

# Off-the-Edge Scallops Sample

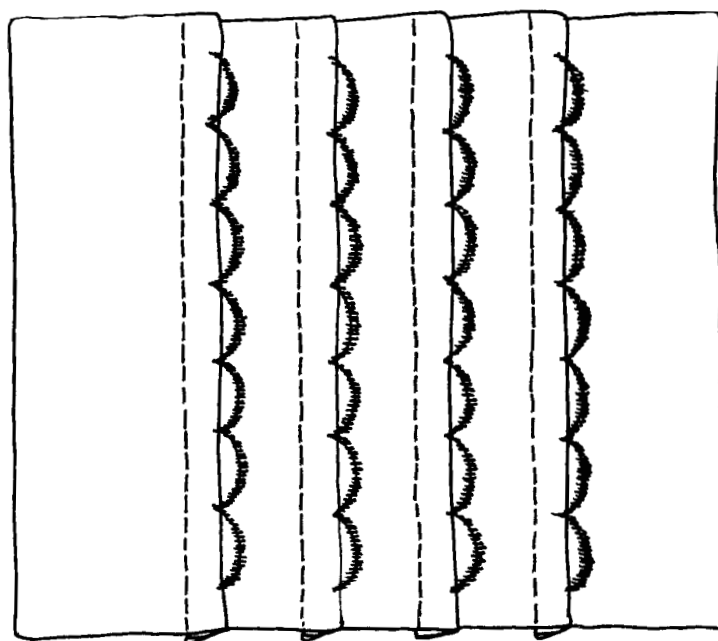

	<b>BERNINA® 1008</b>	<b>220</b>	<b>230PE</b>	<b>240</b>	<b>430</b>	<b>440QE</b>	<b>630</b>	<b>640</b>	<b>200</b>
<b>Straight Stitch</b>	1	1	1	1	1	1	1	1	1
<b>Satin Stitch Scallop</b>	8	34	48	58	88	114	416	416	416



## Lace Insertion

Fabric ..... lightweight cotton 4" x 6"  
 Notions ..... 9" insertion lace, 1/2" - 3/4" wide  
 Needle ..... 70/10 Universal  
 Thread ..... 60 weight cotton  
 Presser Foot ..... **BERNINA®** Edgestitch #10/10C  
 ..... **bernette®** blindhem foot  
 Stitch ..... straight  
 Needle Position ..... half left, half right

## Notes

*First Run:* Pin or spray-baste lace in position on top of fabric. Select straight stitch; adjust length to 1.5mm-2mm.

### BERNINA®

Move needle to half left (**artista** 640 & 200: adjust needle one position to left). Align left edge of lace with guide; sew.

Sew the right side in the same manner using the half right needle position (**artista** 640 & 200: adjust needle one position to right).

### bernette®

Move white blade 1/8" from the needle). Align right edge of lace with guide; sew.

Turn fabric 180° and sew the right side in the same manner.

From the back, *carefully* cut through fabric, between the two rows of stitching, leaving lace intact. Press fabric back against the straight stitch.

*Second Run:* Select zigzag stitch; SW = 1.5-2mm and SL = 0.75-1mm.

### BERNINA®

Move needle to half left (640/200: adjust needle one position to left).

Place edge of lace first to the left of the blade, and zigzag over the edge of the lace and previously sewn straight stitch.

Sew right side in the same way, using a half right needle position (**artista** 640/200: adjust needle one position to right).

### bernette®

Place edge of lace first to the right of the blade, and zigzag over the edge of the lace and the previously sewn straight stitch.

Turn fabric 180° and sew the right side in the same manner.

Trim surplus fabric from wrong side. Trim and mount sample.

# Lace Insertion Sample

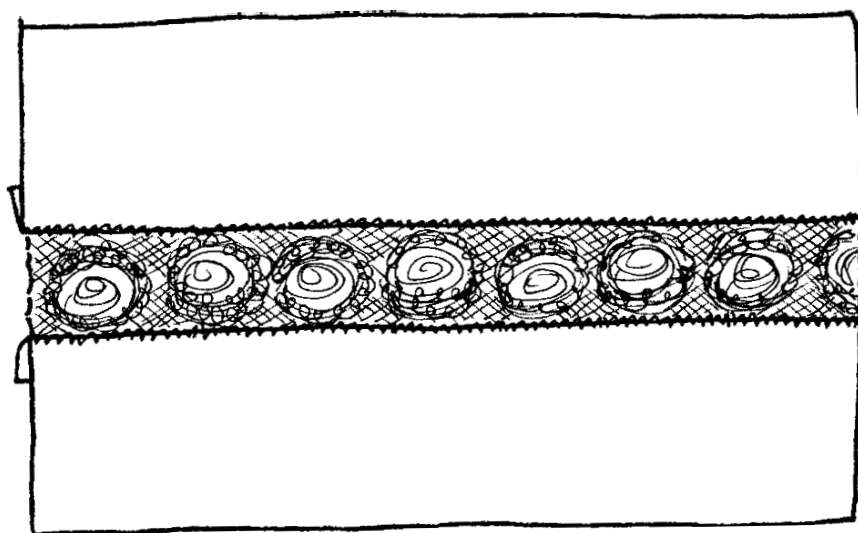

bernette®	55	65	80e	90e
<b>Straight Stitch</b>	2	2	2	2
<b>Zigzag Stitch</b>	3	3	3	3

<b>BERNINA®</b>	<b>1008</b>	<b>220</b>	<b>230PE</b>	<b>240</b>	<b>430</b>	<b>440QE</b>	<b>640</b>	<b>650</b>	<b>200</b>
<b>Straight Stitch</b>	1	1	1	1	1	1	1	1	1
<b>Zigzag Stitch</b>	2	2	2	2	2	2	2	2	2





# Fagoting & Bundling Sample

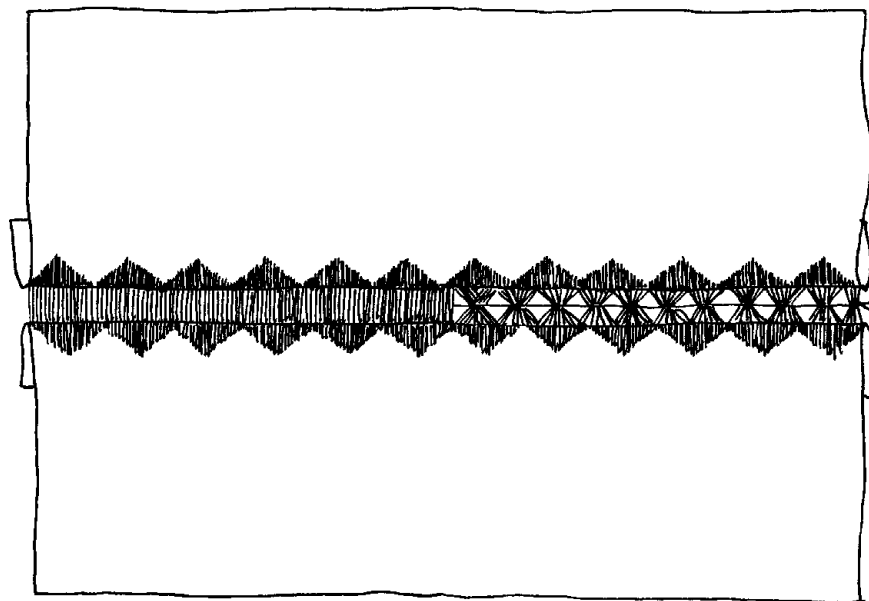

<b>BERNINA® 1008</b>	<b>220</b>	<b>230PE</b>	<b>240</b>	<b>430</b>	<b>440QE</b>	<b>630</b>	<b>640</b>	<b>200</b>
<b>Zigzag Stitch</b>	2	2	2	2	2	2	2	2
<b>Decorative Stitch</b>	13	36	52/53	62/63	70	93	427	427
<b>Triple Straight Stitch</b>	9	6	6	6	6	6	6	6



BERNINA® models only

## Fringing

Fabric ..... firm fabric, 2 pieces, 4 "x 6" each  
 Needle ..... 90/14 Embroidery  
 Thread ..... embroidery  
 Presser Foot..... **BERNINA®** Tailor Tack Foot #7  
 ..... **BERNINA®** Embroidery Foot #6 *or*  
 ..... **BERNINA®** Clear Embroidery Foot #39  
 ..... **BERNINA®** Clear Foot #34/34C  
 Stitches..... zigzag  
 ..... decorative stitches as desired  
 ..... triple straight  
 Needle Position ..... center

## Notes

### Fringing

Select a zigzag stitch with a width of 5mm and a satin stitch length. Attach Tailor Tack Foot #7 to the machine. Insert a bobbin in a contrasting color.

Turn under ½" at one 6" end of one fabric piece; turn under ½" along one 5" end of the remaining fabric piece. Butt folded edges together under the presser foot, right sides up.

Guide fabric while stitching so needle pierces both fabric pieces.

Carefully remove the bobbin thread and gently separate the two fabrics, leaving them joined by strands of the upper thread.

Change to Embroidery Foot #6. Anchor the upper edge of the fringe to the fagoting/bundling sample by oversewing it. Sew halfway with a decorative stitch and remainder with a different decorative stitch.

After fringe is secured on one side, the other fabric can be pulled away.

Trim excess seam allowance from wrong side if needed.

# Fringing Sample

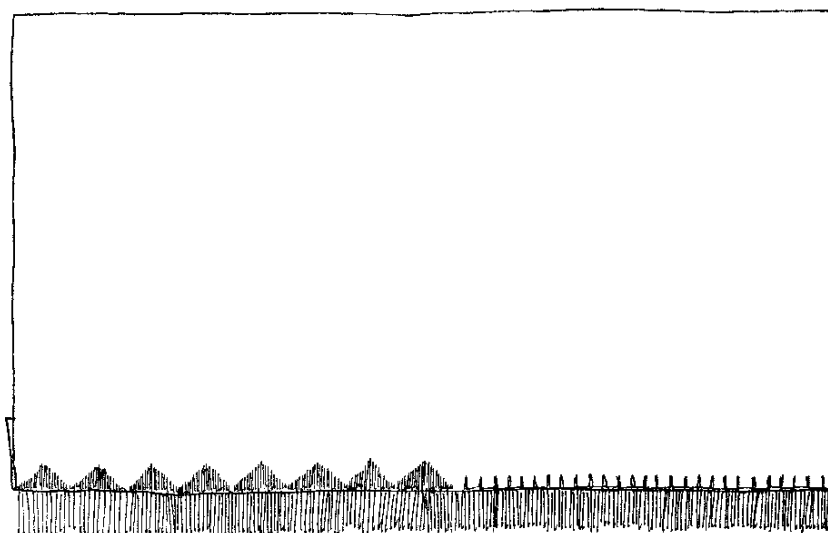

	<b>BERNINA® 1008</b>	<b>220</b>	<b>230PE</b>	<b>240</b>	<b>430</b>	<b>440QE</b>	<b>630</b>	<b>640</b>	<b>200</b>
<b>Decorative Stitch</b>	13	28	26	42	50	45	406	406	406
<b>Triple Straight Stitch</b>	9	6	6	6	6	6	6	6	6
<b>Decorative Stitch</b>	12	36	52/53	62/63	70	93	329	329	329



## Piping

Fabric ..... firmly woven, 6" x 4"  
 Notions ..... bias strips, 2" x 15"  
 ..... 18" length of  $\frac{3}{32}$ " filler cord  
 Needle ..... 90/14 Universal  
 Thread ..... all-purpose  
 Presser Foot ..... **BERNINA®** Bulky Overlock Foot #12/12C  
 ..... **bernette®** zipper foot  
 Stitch ..... straight  
 Needle Position ..... as needed

## Notes

### **BERNINA®** Covered Piping

Fold wrong side of bias strip around filler cord and position it under the presser foot with folded edge to the left and the cord under center of foot so it rides in the large groove.

Using a straight stitch with needle in the half right position, begin stitching. Stitches will be sewn alongside cord, creating a  $\frac{5}{8}$ " seam. Trim seam allowance if necessary.

### **bernette®** Covered Piping

Fold wrong side of bias strip around filler cord and position it under the presser foot with folded edge to the left and the cord under the left side of the foot.

Using a straight stitch with needle in the center position, begin stitching. Stitches will be sewn alongside cord, creating a  $\frac{5}{8}$ " seam. Trim seam allowance if necessary.

Once piping is covered, it is ready to be inserted into a seam.

Cut the other piece of fabric in half, making two 2" x 6" pieces.

### Inserting Piping

Matching raw edges, place piping right sides together with one long fabric edge. Place second piece right sides together with piping and first piece.

### **BERNINA®**

Position fabric/piping under presser foot; adjust needle one position closer to center.

*Note: By adjusting the needle position, the previous stitching will not be seen on the finished project.*

### **bernette®**

Position fabric/piping under left side of presser foot; adjust guide to left.

### **Covered Cord Tips:**

Fabric strips should be cut  $1\frac{1}{4}$ " plus the circumference of the cord being used. Trim the 2" strip, if needed, to work with the cording being used. This should result in a  $\frac{5}{8}$ " seam allowance on the finished piping.

Strips for covering cord are generally cut on the bias (diagonal); however, cross-wise and lengthwise strips may be used if there are no corners to be turned or curves to maneuver.

# Piping Sample

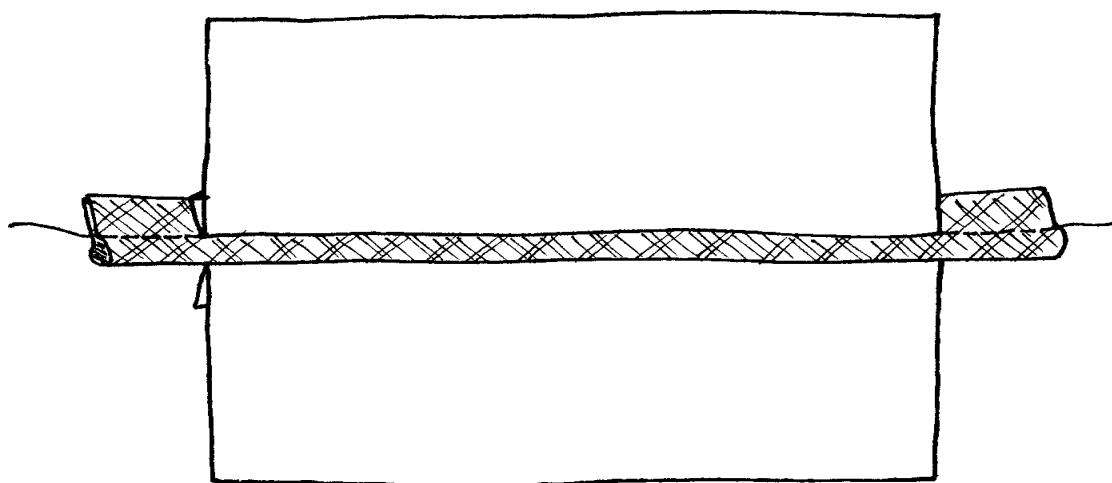

bernette®	55	65	80e	90e
Straight Stitch	2	2	2	2

<b>BERNINA®</b>	<b>1008</b>	<b>220</b>	<b>230PE</b>	<b>240</b>	<b>430</b>	<b>440QE</b>	<b>630</b>	<b>640</b>	<b>200</b>
Straight Stitch	1	1	1	1	1	1	1	1	1
Needle Positions	5	9	9	9	11	11	11	11	11



# Patchwork/Quilting

- Fabrics ..... medium print cotton, one 4" x 8" center strip  
 ..... "solid" print cotton, two 4" x 8" strips  
 ..... print cotton, one 8" x 12" square (backing)
- Stabilizer ..... thin cotton batting, 8" x 12"  
 ..... temporary adhesive spray (ex: HRFive)
- Needle ..... 90/14 Quilting
- Thread ..... 50 weight cotton thread  
 ..... clear monofilament ("invisible" thread)
- Presser Feet ..... **BERNINA®** Patchwork Foot #37 **or**  
 ..... **BERNINA®** Patchwork Foot with Guide #57  
 ..... **BERNINA®** Walking Foot #50  
 ..... **BERNINA®** Leather Roller Foot #55  
 ..... **BERNINA®** Freemotion Quilting Foot #29/29C  
 ..... **bernette®** quilting foot  
 ..... **bernette®** walking foot  
 ..... **bernette®** darning/embroidery foot
- Stitches ..... straight, hand-look quilting
- Needle Position ..... center

## Notes

### Patchwork

**BERNINA®**  
 Seam "solid" strips to each side of center print strip using Patchwork Foot #37 **or** Patchwork Foot with Guide #57 and a ¼" seam allowance. Press seams to sides.

**bernette®**  
 Seam "solid" strips to each side of center print strip using the mark at the right of the right toe of the quilting foot and a ¼" seam allowance. Press seams to sides.

Create a "quilt sandwich" by placing batting between patchwork and backing square, wrong sides to the batting. Use a temporary adhesive spray such as HRFive to "baste" the layers together.

## Patchwork/Quilting

### Quilting “In-the-Ditch”

Attach walking foot to sewing machine. Select straight stitch.

Stitch in the “ditch” of the seams between blocks or pieces.

### Hand-Look Quilting Stitch

(**BERNINA®** electronic & **bernette®** 80e & 90e machines only)

Attach the walking foot to the sewing machine.

Insert a bobbin of colorful cotton thread into the machine; thread the needle with clear monofilament thread.

Select hand-look quilting stitch. Stitch along outer edge of the patchwork seams, about  $\frac{1}{8}$ ” to  $\frac{1}{4}$ ” from the seamline. Increase tension as necessary; bobbin threads should pull to surface to form “stitches”; monofilament creates “spaces” between stitches.

### Stippling

Thread the needle with cotton quilting thread. Select straight stitch and lower the feed dog.

#### **BERNINA®**

Attach Freemotion Quilting Foot #29/29C to the machine.

#### **bernette®**

Attach the darning/embroidery foot to the machine.

Using needle and thread as a “pencil”, doodle in the two “solid” patches, moving the fabric “paper” under the needle. It takes a bit of practice to get the hang of this; be patient and you’ll soon learn to coordinate hand movements and motor speed. Lines of stippling should not cross over each other, the stitches should be about 2.5mm long, and all lines should be curves.

This is one sewing technique that can be practiced with a pencil and paper. Practice your stippling technique by holding a pencil straight up and down and doodling in the “spaghetti” patterns of stippling stitches. Freemotion embroidery and quilting can be practiced in the same way.

Owner’s manual: \_\_\_\_\_

## Notes:



## Patchwork/Quilting

### Outline Quilting

Thread the needle with cotton quilting thread. Select a straight stitch with a length of 2.5mm.

#### **BERNINA®**

##### **Leather Roller Foot #55**

Attach Leather Roller Foot #55 to machine. Move needle to left as needed. Foot #55 will hold the fabric in place as you “roll” around the fabric.

#### **bernette®**

##### **Darning/Embroidery Foot**

Attach the darning/embroidery foot to the machine.

Using needle and thread as a “pencil”, trace outlines about ¼” from the printed figures in the center strip of the quilt block.

If available, engage the Needle Stop Down function when quilting. This will cause the needle to always stop down in the fabric, lessening the chance of the fabric shifting each time stitching is stopped and started again.

Practice makes perfect. Before quilting, create a sample “quilt sandwich” using the same fabrics and batting as your project. Practice stitching perfect curves and corners. Even experienced quilters can always use a warm-up before stitching.

## Notes

# Patchwork/Quilting Sampler

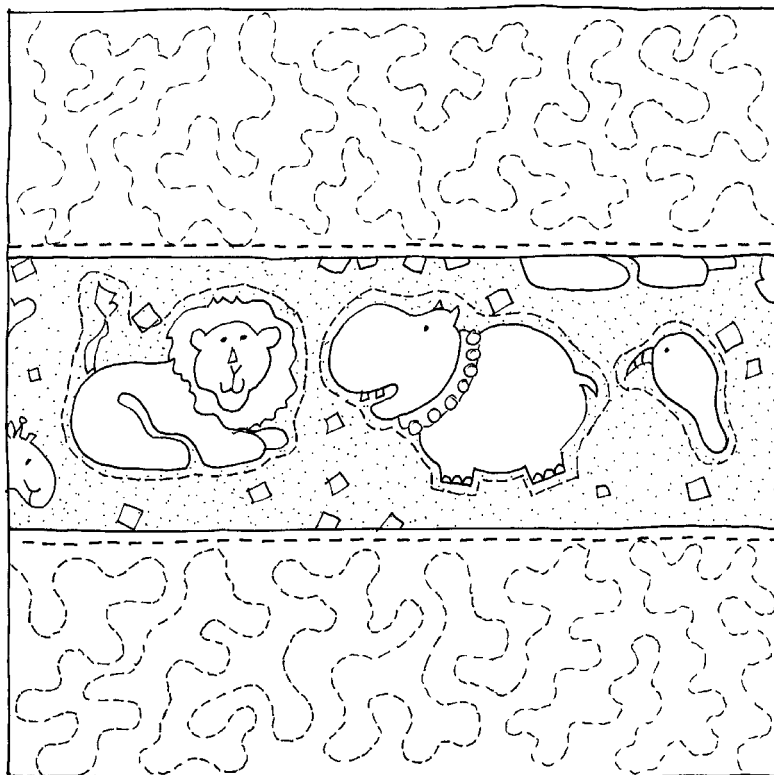

bernette®	55	65	80e	90e
Straight Stitch	2	2	2	2
Hand-Look Quilt Stitch	--	--	15	16

BERNINA® 1008	220	230PE	240	430	440QE	630	640	200
Straight Stitch	1	1	1	1	1	1	1	1
Hand-Look Quilt Stitch	--	27	24	40	49	44	328	328

BERNINA® models with BSR capability only (430/440/630/640/200)

## BERNINA® Stitch Regulator

The BERNINA Stitch Regulator (BSR) is designed to assist with freemotion stitching techniques by keeping the stitch length regular and consistent.

The BSR is a standard accessory for the **aurora** 430, and available as an optional accessory for the **aurora** 440 and **artista** 630/640, and as an upgrade for the **artista** 200.

The BSR Foot is equipped with three unique soles, each designed for different sewing situations:

- A **closed, O-shaped, metal sole**, similar to that of Darning Foot #9, for detailed freemotion stitching techniques such as stippling, bobbin-work, and thread painting.
- An **open, C-shaped, metal sole**, similar to that of Freemotion Embroidery Foot #24, for added visibility in front of needle when following printed or marked lines. The “prongs” of this sole are slightly curved, facilitating movement over several layers of fabric and/or thread.
- A **large, clear plastic sole** for echo-quilting and medium-to large-scale freemotion stitching techniques. The large sole moves easily over raised areas and is useful for stitching thick batts, as it compresses a larger area around the needle, increasing visibility. Cross-hairs and concentric circle markings aid in perfect stitch placement .

Experiment with each sole; personal preference plays a major role in determining which sole is most appropriate for you to use with each project and/or technique.

## Notes

## **BERNINA®** Stitch Regulator

### **Changing BSR Soles**

To remove a sole from the BSR foot, press the release buttons (indicated in drawing at right by red arrows) and slide the sole along the angled grooves.

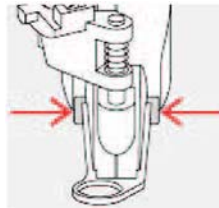

To attach a sole to the BSR foot, place it over the angled grooves and slide it up until it clicks into place.

### **Installing the BSR Foot**

Lower feed dog. Attach desired sole to BSR as instructed above.

Attach the BSR foot to the sewing machine.

Insert BSR plug into the green socket located under the lower left corner at the back of the machine. *Hint: To easily locate the socket, look for its reflection on the slide-on tray.*

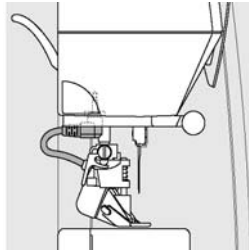

**aurora** 430/440: The BSR symbol will appear on left side of display screen, and presser foot icon will indicate Foot #42 (BSR). Press the BSR/Balance button; Mode 1 or Mode 2 – whichever was used last – will be selected, with stitch length set at 2.0 mm (if machine has not been turned off, settings will automatically return to the ones last used with the selected Mode). Stitch length may be adjusted from 1-4 mm.

**artista** 630/640: The BSR screen opens automatically when the plug is inserted into the socket. Mode 1 will automatically be selected, with stitch length set at 2 mm. Stitch length may be adjusted from 1-4 mm.

Select Mode 1 or Mode 2 by pressing the appropriate number on the keypad. *Note: For further information, see exercises on pages 114-117.*

Activate BSR and start stitching by stepping on the foot control, or by unplugging the foot control and pressing the Stop/Start button. *Note: A red sensor in the foot will glow when machine is run in BSR mode.*

Owner's manual: \_\_\_\_\_

**Notes:**



BERNINA® models with BSR capability only (430/440/630/640/200)

## BERNINA Stitch Regulator: Mode 1

Fabric .....	medium weight cotton, two 12" x 12" squares
Stabilizer .....	thin cotton batting, 12" x 12"
.....	temporary adhesive spray (HRFive)
Needle .....	90/14 Quilting
Thread .....	King Tut 40 weight thread (Superior Threads)
.....	Bottom Line thread (Superior Threads)
Presser Feet.....	<b>BERNINA®</b> Stitch Regulator (BSR) #42
Stitch .....	straight stitch, BSR Mode 1
Stitch Length .....	2.0-2.5 mm
Presser Foot Pressure .....	1

### Notes

Install and activate BSR; lower feed dog. Check to be sure motor speed is set to full. *Note: It is possible to stitch faster than the BSR can regulate. Engage audio signal to alert you when you exceed the "speed limit."*

When working in BSR Mode 1, there is constant power to the needle whenever the motor is engaged, whether using the foot control or the Stop/Start button (430/440/630/640 only). Rather than stopping, the needle continues to move up and down very slowly; some stitchers prefer this mode for leaves, tendrils, and other meandering lines.

Layer fabric & batting to make a "quilt sandwich." Thread machine with King Tut in needle & Bottom Line in bobbin. Place fabric under BSR foot.

Step on the foot control but do not move fabric/hands. Notice that the needle moves up and down. Release foot control. **aurora 430/440 and artista 630/640 only:** Remove foot control. Press the Stop/Start button to engage the motor. Notice that the needle moves up and down. Press the Stop/Start button to stop the motor.

- Using the foot control or the Stop/Start button, move the fabric in a forward and back motion (1).
- Move hands from side to side, then top to bottom, keeping the lines perpendicular to each other (2).
- Move hands in smooth curves from left to right (3).
- Move hands in cursive "l" shapes (4).
- Create stippling shapes – think of interconnecting puzzle pieces with evenly sized "bumps." Avoid "painting" yourself into a corner and/or stitching across a previously stitched line (5).

# BERNINA Stitch Regulator: Mode 1 Sample

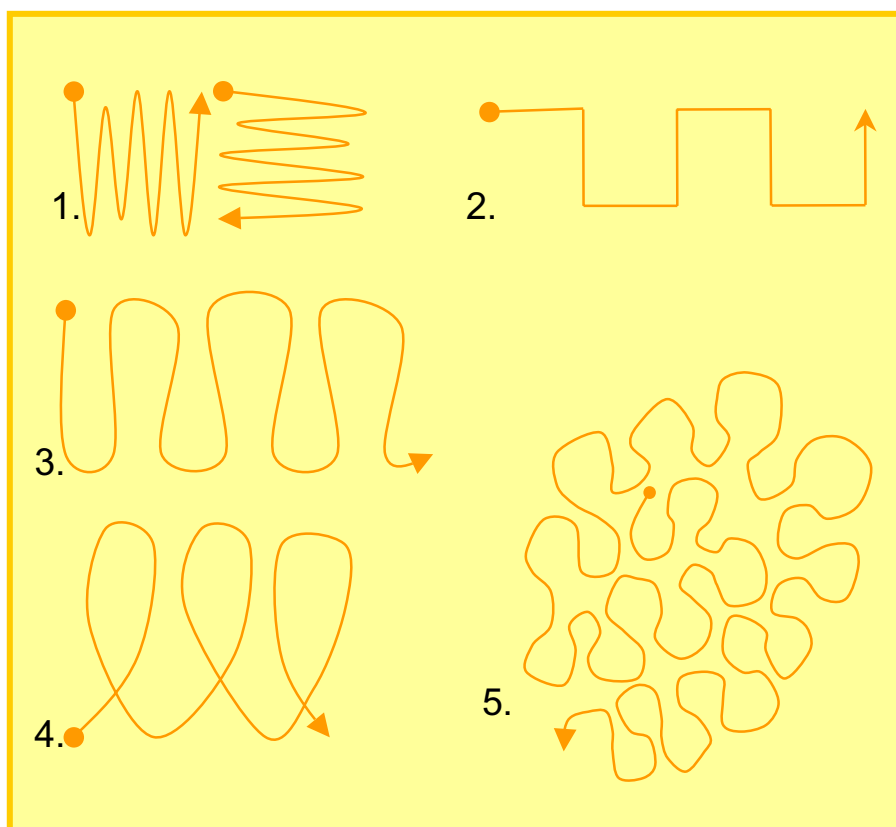



BERNINA® models with BSR capability only (430/440/630/640/200)

## BERNINA Stitch Regulator: Mode 2

Fabric .....	medium weight cotton, two 12" x 12" squares
Stabilizer .....	thin cotton batting, 12" x 12"
.....	temporary adhesive spray (HRFive)
Needle .....	90/14 Quilting
Thread .....	King Tut 40 weight thread (Superior Threads)
.....	Bottom Line thread (Superior Threads)
Presser Feet.....	<b>BERNINA®</b> Stitch Regulator (BSR) #42
Stitch .....	straight stitch, BSR Mode 2
Stitch Length .....	2.0-2.5 mm
Presser Foot Pressure .....	1

### Notes

Install and activate BSR; lower feed dog. Check to be sure motor speed is set to full. *Note: It is possible to stitch faster than the BSR can regulate. Engage audio signal to alert you when you exceed the "speed limit."*

When working in BSR Mode 2, the motor is engaged only when the fabric is moved under the foot, giving the stitcher time to stop and think about the path the needle is taking. Just as with Mode 1, the motor can be engaged using the foot control or the Stop/Start button (430/440/630/640 only). *Note: If there is no movement for over seven seconds, the BSR will automatically be deactivated.*

Layer fabric & batting to make a "quilt sandwich." Thread machine with King Tut in needle & Bottom Line in bobbin. Place fabric under BSR foot.

Step on foot control but do not move fabric. Notice that needle moves up, preparing machine for stitching. Begin moving fabric; motor is engaged and begins stitching. Stop moving fabric; motor is disengaged and needle stops moving. Release foot control. **aurora 430/440 and artista 630/640 only:** Remove foot control. Press Stop/Start button to engage motor. Needle moves up & down. Press Stop/Start button to stop motor.

- Using foot control or Stop/Start button, move fabric in a forward and back motion (1).
- Move hands from side to side, then top to bottom, keeping lines perpendicular to each other (2).
- Move hands in smooth curves from left to right (3).
- Move hands in cursive "l" shapes (4).
- Create stippling shapes – think of interconnecting puzzle pieces with evenly sized "bumps." Avoid "painting" yourself into a corner and/or stitching across a previously stitched line (5).

**Mode 1 or Mode 2?**  
 Try each mode with various techniques (quilting, sashiko, trapunto, bobbinwork, silk-ribbon embroidery, etc.) to determine your favorite for each situation.

# BERNINA Stitch Regulator: Mode 2 Sample

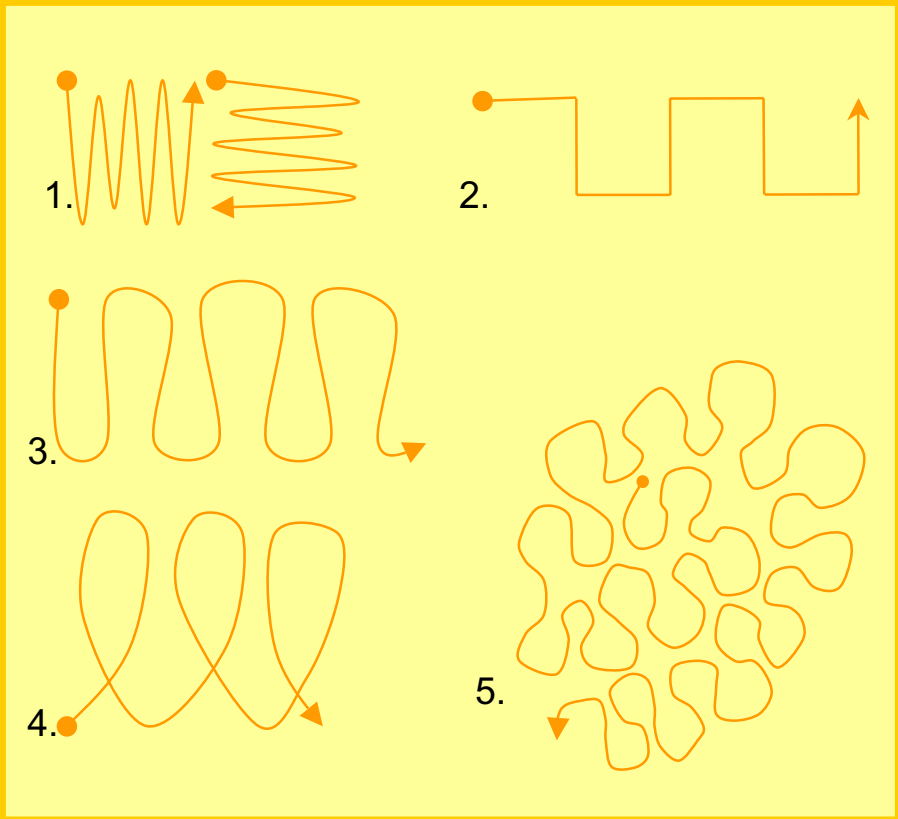
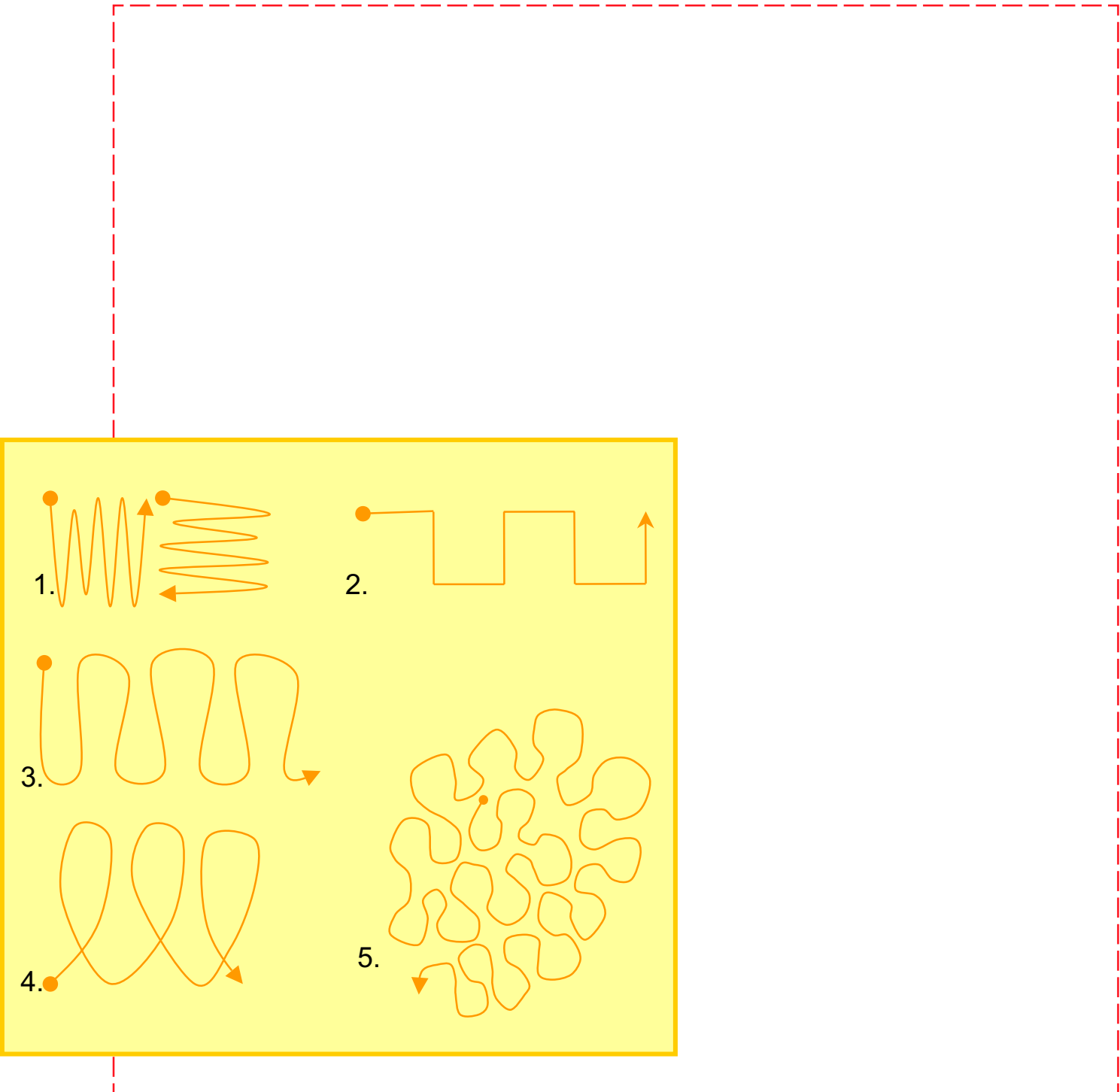





**BERNINA® models with zigzag BSR capability only (630/640/200)**

## BERNINA Stitch Regulator: Zigzag

Fabric .....	medium weight cotton, two 12" x 12" squares
Stabilizer .....	thin cotton batting, 12" x 12"
.....	temporary adhesive spray (HRFive)
Needle .....	90/14 Quilting
Thread .....	King Tut 40 weight thread (Superior Threads)
.....	Bottom Line thread (Superior Threads)
Presser Feet .....	<b>BERNINA®</b> Stitch Regulator (BSR) #42
Stitch .....	BSR Mode 1 or 2
Stitch Length & Width .....	preset
Presser Foot Pressure .....	1

### Notes

Use the BSR zigzag option to easily and quickly create freehand embroidery designs, shade or accent fabric motifs, and couch decorative fibers. Experiment with bobbinwork and other free-motion techniques to create stunning fabric embellishments.

1

Trace or draw leaf shape (1) on fabric. Layer fabric and batting to create a "quilt sandwich." Thread machine with King Tut in the needle and Bottom Line in the bobbin. Place fabric under the BSR foot.

- Select straight stitch and preferred mode. Stitch the leaf shape, tracing lines several times (2).
- Select zigzag stitch and preferred mode. Shade the left side of the leaf (3).

Experiment with different stitch lengths and widths, making note of your preferences.

# BERNINA Stitch Regulator: Zigzag Sample

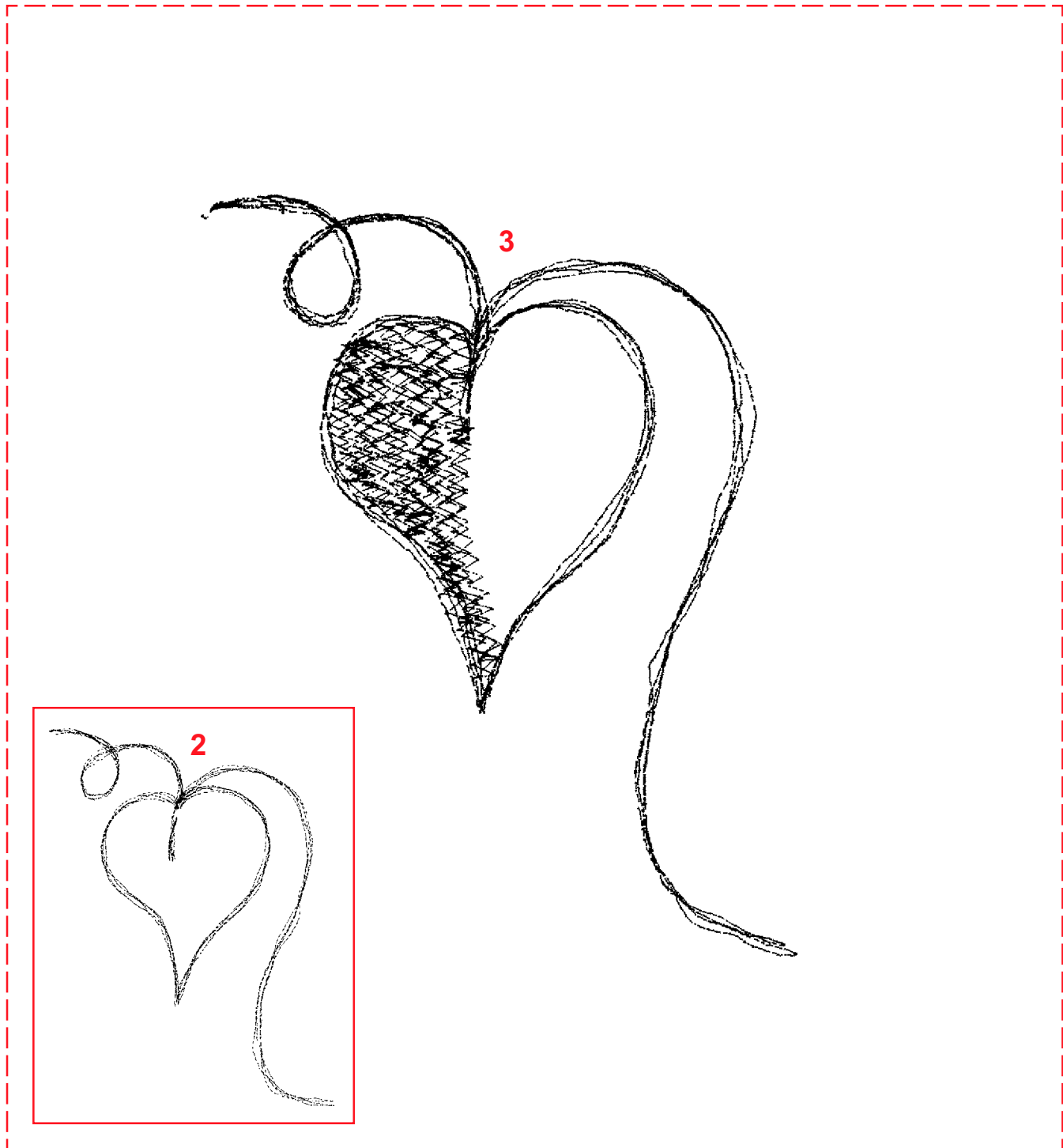

# Applique

- Fabric ..... 2 pieces woven cotton, 6" x 6", two colors
- ..... 3" x 3" scrap of fabric in a third color for applique
- Stabilizer ..... lightweight tear-away, 6" x 6"
- ..... HRFive spray adhesive
- Notions ..... 12" of single fold bias tape
- Needle ..... 80/12 Universal
- Thread ..... 50 weight cotton
- ..... clear monofilament ("invisible" thread)
- Presser Feet ..... **BERNINA®** Clear Foot #34/34C
- ..... **BERNINA®** Open Embroidery Foot #20/20C
- ..... **BERNINA®** Circular Embroidery Attachment #83
- ..... **bernette®** zigzag/universal foot
- ..... **bernette®** satin stitch foot
- Stitches ..... straight, satin, blindhem
- Needle Position ..... center

## Preparation

Cut a heart from the 3" x 3" piece of fabric.

Stack 6" x 6" fabrics squares, all right side up:

- stabilizer on bottom,
- one fabric in the middle,
- the other fabric on top.

### **BERNINA®**

Mark a point on the top layer; this will be the center of the reverse applique circle.

### **bernette®**

Draw a 4" circle in the center of the top layer.

## Notes

### **Adhesive Sprays**

*A variety of spray adhesive are available, many specially designed for fabric and sewing applications.*

*202 Temporary Adhesive - Adheres paper patterns to fabric.*

*404 Permanent Repositionable Adhesive - Creates "sticky notes" and other "re-stickable" items.*

*HRFive Adhesive Spray - Water-soluble; washes out completely. Can be used as a repositionable spray; item stays sticky, but can be moved and bonded to another surface. Works great on paper, and as a no-show adhesive on vellum.*

*505 Temporary Adhesive - Especially good for applique and quilt basting; does not gum-up needles.*

*606 Fusible Adhesive - Bonds with heat; for iron-on patches and appliques.*

*HRZero Adhesive Remover - Removes adhesive residue from plastic, metal, wood, glass, stone, and ceramics.*

# Applique - continued

## Reverse Applique

### **BERNINA®**

Attach Circular Embroidery Attachment #83 to the machine arm. Remove rubber cap from pin. Place layered fabric over attachment, aligning mark over pin. Push fabric down over pin, taking care not to pierce fingers. Replace cap on pin. Check size of circle by turning fabric around pin. Adjust setting as needed so edge of circle is within fabric square.

Attach Clear Foot #34/34C to machine. Select straight stitch. Sew, letting the fabric turn around the pin as it feeds under the foot. Overlap ends ½”.

Carefully remove fabric from attachment without moving pin. Using sharp scissors, trim away topmost fabric layer from within circle. Replace fabric on pin, making sure pin pierces through the same point in center of circle.

Select satin stitch (zigzag with SL of approximately 0.3mm). Adjust SW to 3mm. Attach Open Embroidery Foot #20/20C. Stitch around circle, covering previous stitching and raw edge of fabric. Overlap stitching slightly at end; pull thread tails to back and knot.

Move point of attachment 1 notch away from needle. Select heart stitch (or other decorative stitch). Sew around circle once more; hearts form just outside satin-stitched circle.

### **bernette®**

Attach zigzag/universal foot to the machine. Select straight stitch. Stitch along the drawn line, around the entire circle. Overlap ends ½”.

Remove fabric from machine. Using sharp scissors, carefully trim away the topmost layer of fabric from within the circle.

Select a satin stitch (zigzag stitch with a stitch length of approximately 0.3mm). Adjust the stitch width to 3mm. Attach satin stitch foot to machine. Stitch around circle, covering the previous stitching and the raw edge of the cut fabric. Overlap slightly at end; pull thread tails to back and knot.

Select square stitch (or other decorative stitch). Sew around the circle one more, slightly outside the previous stitching.

Owner's manual: \_\_\_\_\_

## Notes:

## Applique - continued

### Blanket Stitch Applique

(**BERNINA®** electronic & **bernette®** 65/80e/90e machines only)

Fuse heart (or other applique shape) to base fabric as desired, using 606 fusible spray adhesive.

Thread needle with cotton thread. Attach **BERNINA®** Open Embroidery Foot #20/20C / **bernette®** satin stitch foot to machine. Select blanket stitch (adjust width to 3mm if necessary); mirror image if necessary so the perpendicular stitches point to the left.

Stitch along all sides of the fused applique shape, with straight portion of the stitch falling on the raw edge and “points” stitching into the applique. At corners, use the Needle Stop Down function, if available, to stop with the needle down in the fabric. Move needle position to far right. Lower feed dog. Stitch; because the feed dog is lowered, the machine stitches in place, creating a handsewn look at the inner corner.

Use the Free Hand System to raise presser foot; pivot fabric. Lower the presser foot, re-engage feed dog, and continue sewing. If desired, use the triple blanket stitch for a portion of the applique.

### Hand-Look Applique

Arrange bias strip on fabric as desired, creating a soft curve. Pin strip in place.

#### **BERNINA®**

Select quilting blindstitch (or a regular blindstitch with width of 0.5mm). Attach Open Embroidery Foot #20/20C to machine. Move needle position to far right.

#### **bernette®**

Select the blindstitch; adjust width to 2mm and length to 1.5mm. Attach the satin stitch foot to the machine.

Thread needle with monofilament thread. Applique strip in place, guiding the foot so that the straight part of the stitch sews “in-the-ditch”, while the zigzag portion barely bites into the folded edge of the applique.

## Notes

# Applique Sampler

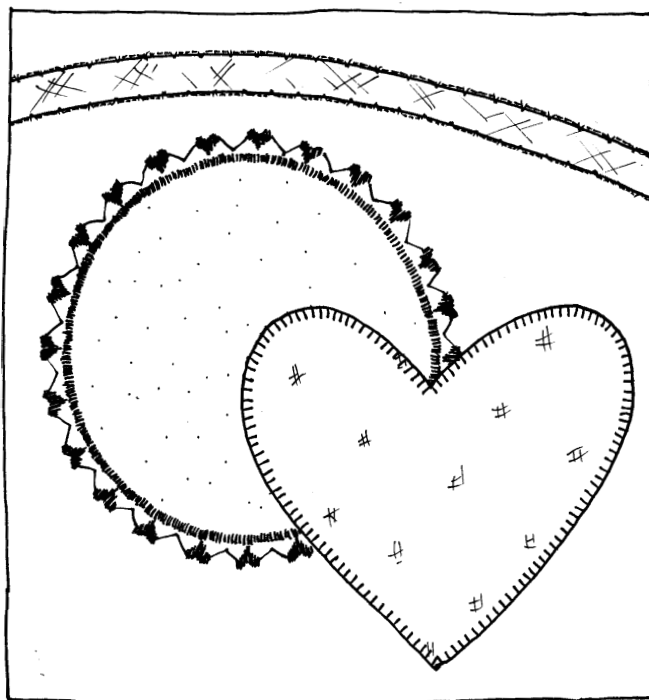

bernette®	55	65	80e	90e
Square Stitch	13	9	10	11
Blanket Stitch	--	13	14	15
Hand-Look Applique	4	5	12	13

BERNINA® 1008	220	230PE	240	430	440QE	630	640	200
Heart or Scallop Stitch	8	32	46	55	76	99	413	413
Blanket Stitch	--	28	25	41	50	45	329	329
Hand-Look Applique	3	7	7	7	52	47	331	331

# Surface Embellishment

- Fabric ..... sturdy muslin, 6" x 6"  
..... assorted 2½" x 9" strips (8-10 different fabrics)
- Notions ..... cord, yarn or other round trim  
..... small, stranded beads  
..... narrow ribbon, 5mm wide (9mm for 640 & 200)
- Needle ..... 80/12 Embroidery or Sharp
- Thread ..... plain & variegated embroidery threads  
..... heavy decorative threads
- Presser Foot ..... **BERNINA®** Patchwork Foot #37  
..... **BERNINA®** Open Embroidery Foot #20/20C  
..... **BERNINA®** Braiding Foot #21/12C  
..... **BERNINA®** Bulky Overlock Foot #12/12C  
..... **BERNINA®** Black Latch *or* Supplementary Bobbin Case  
..... *bernette®* quilting foot  
..... *bernette®* satin stitch foot  
..... *bernette®* cording foot  
..... *bernette®* 65/80e/90e only: extra bobbin case
- Stitches ..... various stitches, as indicated
- Needle Position ..... center

## Notes

### Preparation: Crazy Patchwork

Cut a 5-sided shape from one patchwork strip. Place right side up in center of muslin square. Select another patchwork strip; place right sides together with center patch, matching one raw edge. Stitch, stopping at the end of the first patch. Flip open; press.

Select a second patchwork strip. Place along the next edge of the center patch, over the previously stitched strip. Seam; flip; press. Trim excess fabric from underneath the strip.

Continue adding strips in this manner, working in a circular direction around the center patch, until the entire base fabric is covered. Straight stitch close to the outer edges of the muslin base fabric; trim excess fabric from around the edges of the square.

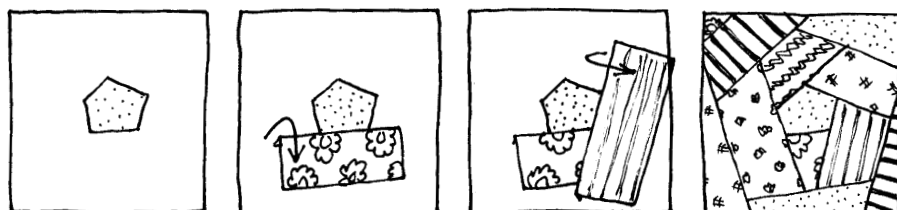

## Surface Embellishment - continued

### Decorative Stitching

Attach **BERNINA®** Open Embroidery Foot #20/20C / **bernette®** satin stitch foot to the machine. Thread needle with variegated embroidery thread.

Select an open floral or honeycomb stitch. Sew over one of the patchwork seams, centering the stitch over the seam. Select a different stitch; sew another seam. Embellish seams as desired.

### Bobbinwork

(**BERNINA®** electronic & **bernette®** 65/80e/90e machines only)

*Note: Use extra bobbin case only! Do NOT adjust your regular bobbin case!*

Wind a bobbin half full of heavy decorative thread, such as Designer 6 or Pearl Crown Rayon. Insert bobbin into Black Latch Bobbin Case (or an extra bobbin case); adjust (loosen, in most cases) tension screw as necessary.

Select a feather stitch. Place patchwork *right side down* under presser foot, with the muslin backing facing up. Stitch along one of the unembellished seam lines. When finished, turn block right side up; the bobbin thread is visible on the right side of the block and resembles hand stitched embroidery.

**BERNINA®** only: Repeat, using the entredeux stitch. The bobbinwork on the fabric surface forms small “roses”.

Owner's manual: \_\_\_\_\_

## Notes:





## Surface Embellishment - continued

### Couching

#### BERNINA® Ribbon

Attach Open Embroidery Foot #20/20C to the machine.

Select a stipple, floral, or other decorative stitch. Place ribbon over a seam; stitch in place, centering ribbon between the toes of the foot.

#### bernette® Ribbon

Attach the zigzag/universal foot to the machine.

Select a blanket, zigzag, or other decorative stitch. Place the ribbon over a seam; stitch in place, sewing through the center of the ribbon.

#### BERNINA® Yarn

Attach Braiding Foot #21/12C to machine. Select a yarn or trim; thread through opening in foot.

Select a ladder, double overlock, or universal stitch. Couch yarn or trim over a seam, centering yarn over the seam.

#### bernette® Heavy Threads

Attach cording foot to machine. Select three heavy decorative threads; thread through the grooves in the front of the foot.

Select a sewn out zigzag stitch. Couch the decorative threads over a seam.

**BERNINA® only: Beads:** Select a triple zigzag stitch; adjust length and width to 5mm. Thread a strand of beads through the opening in Bulky Overlock Foot #21/12C.

Begin stitching; adjust stitch length so stitches fall between beads. Continue stitching, couching beads over one of the patchwork seams.

## Notes

bernette®	55	65	80e	90e
Honeycomb	9	12	S4	S4
Blanket	--	13	14	15
Square	13	9	10	11
Scallop	12	8	11	12
Universal	--	7	6	6
Triple Zigzag	8	14	S3	S3
Sewn Out Zigzag	5	4	4	4

# Surface Embellishment Sampler

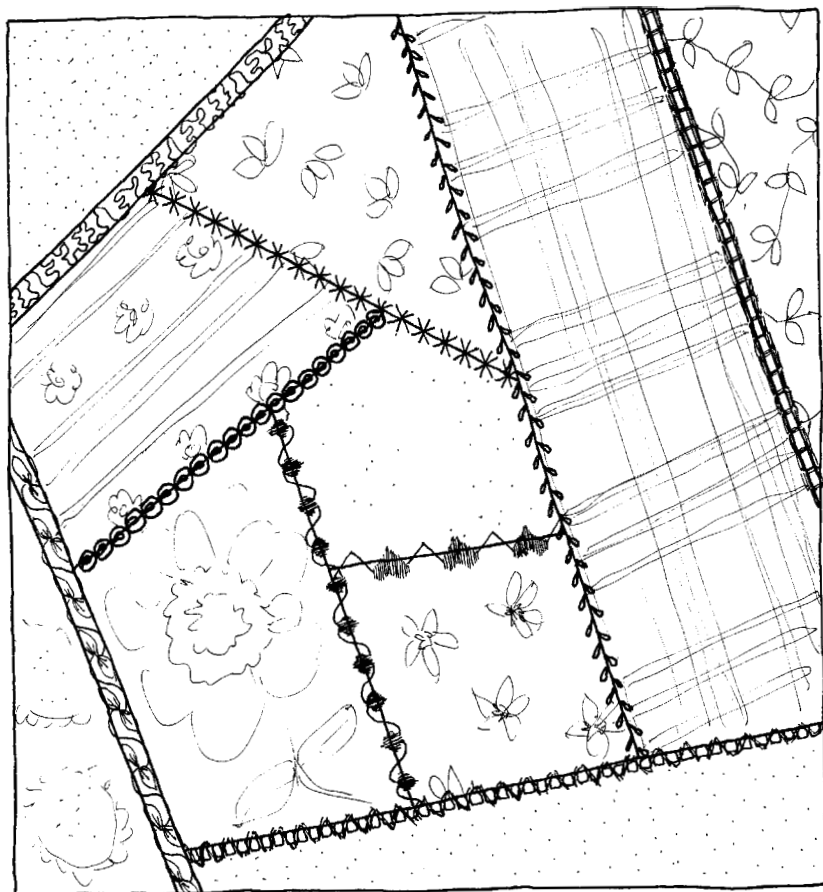

	<b>BERNINA® 1008</b>	<b>220</b>	<b>230PE</b>	<b>240</b>	<b>430</b>	<b>440QE</b>	<b>630</b>	<b>640</b>	<b>200</b>
<b>Floral</b>	--	43	65	88	41	83	106	106	106
<b>Feather</b>	--	45	28	44	53	48	332	332	332
<b>Entredeux</b>	--	41	59	76	118	147	701	701	701
<b>Stipple</b>	--	26	23	39	48	43	327	327	327
<b>Ladder</b>	--	--	60	77	119	148	702	702	702
<b>Universal</b>	4	17	20	23	24	26	15	15	15
<b>Triple Zigzag</b>	10	6	6	6	6	6	7	7	7

## Class 5

# Product Reference List

## More Decorative Techniques

- Feet-ures*, Volumes 1 and 2
  - BERNINA® Embroidery Foot #6
  - BERNINA® Tailor Tack Foot #7
  - BERNINA® Darning Foot #9
  - BERNINA® Edgestitch Foot #10 *or*
  - BERNINA® Edgestitch Foot #10C
  - BERNINA® Bulky Overlock Foot #12 *or*
  - BERNINA® Bulky Overlock Foot #12C
  - BERNINA® Zipper Foot with Guide #14
  - BERNINA® Cording Foot #22
  - BERNINA® Cording Foot #25
  - BERNINA® Freemotion Quilting Foot #29 *or*
  - BERNINA® Freemotion Quilting Foot #29C
  - BERNINA® Invisible Zipper Foot #35
  - BERNINA® Walking Foot #50
  - BERNINA® Leather Roller Foot #55
  - bernette® Quilting Foot
  - bernette® Satin Stitch Foot
  - bernette® Cording Foot
  - bernette® Darning/Embroidery Foot
  - bernette® Walking Foot
  - bernette® Zipper Foot
  - bernette® Blindhem Foot
  - Secondary Bobbin Case (Black Latch)
- 
- BERNINA® Ironing System
  - BERNINA® Iron

- HRFive Spray Adhesive
- Spring Hoops (for mending)
- Thread Stand
- Blunt Point Scissors (for lace)
- Cotton Batting
- Fusible Interfacing

### Decorative Threads

- Metallic
- Rayon
- Cotton
- Polyester

### “Invisible” Monofilament Thread (0.004 mm)

- Smoke
- Clear

### Couching Threads

- YLI Candlelight
- YLI Pearl Crown Rayon
- YLI Designer 6
- Designer Threads (QRI)
- Ribbon Floss

### Needles

- Single Wing
- Double Wing
- Quilting
- Embroidery

# Class 6

## Stitch Manipulations

### Class Overview

#### Function & Memory Basics

(All Models with Memory Capabilities)

##### Memory – Basic Information

- Accessing Memory
- Programming
- Editing Memory
- Saving & Leaving Memory
- Memory Capacity
- Viewing Memory Contents

##### 1 Function Sampler

- Motor Speed
- Needle Stop Up/Down Adjustment
- Continuous Reverse
- Basting/Long Stitch
- Pattern Begin/Repeat/End
- Stitch Selection by Number
- Securing Function
- Mirror Image
- Pattern Extend
- Balance
- Needle Limitation/Security Program
- Stitch Counter

##### 2 Programming & Editing Sampler

##### 3 Memory Sampler

##### 4 Buttonhole Memory

*The following exercises & information are for **artista** machines, but may be of interest to other machine owners.*

#### **artista** Memory Samplers

##### 5 Memory/Combi Mode Sampler

- Creating & Saving a Stitch Combination
- Inserting Stitches
- Altering & Deleting Stitches

##### 6 Memory/Sub-Divider 1 Sampler

#### Special *artista* Features

- Setup Program
  - Screen Contrast
  - Start Screen
  - Sewing Light
  - Motor Speed
  - Thread Tension
  - Functions
  - Touch Screen
  - Software Version Information
  - Hoop Adjustment
  - Auto Thread Cutter
  - Messages & Audio Signals
  - Stitch Length, Width, Needle Position
  - Personal Program
  - Portal Provider Settings (200 only)
  - Return to Basic Settings
  - esc & Leave Setup
  - Thread Brand
- Tutorial
- Creative Consultant

This class is formatted for owners of the following models of BERNINA® sewing machines:

- **activa** 220
- **activa** 230PE
- **activa** 240
- **aurora** 430
- **aurora** 440QE
- **artista** 630
- **artista** 640
- **artista** 200

# Memory – Basic Information

## *activa & aurora*

### Accessing Memory

Owner's manual page \_\_\_\_\_

- Press the external **mem** button on the front of the machine.
- Memory cursor appears at left, the number of available spaces blinks, and the word **mem** appears on screen.

### Programming

Owner's manual page \_\_\_\_\_

- Select desired stitch; the stitch number appears on screen.
- Touch the **mem** button; the selected stitch is programmed. The number of available spaces appears on screen.
- Continue programming in this manner.
- Scroll through programmed memory using the arrows on either side of the **mem** button.
- Altered stitches can be saved in memory; including length, width, and needle position.
- Delete all unwanted stitches before programming.

## *artista 630/640/200*

### Accessing Memory

Owner's manual page \_\_\_\_\_

- Touch the Combi-Mode symbol. The Stitch Altering Area (SAA) appears on screen, ready for stitch input.

### Programming

Owner's manual page \_\_\_\_\_

- Select desired stitch; it is automatically entered into the Stitch Altering Area. Notice that the background of the selected stitch is BLUE and that there is a RED cursor along the lower edge of the selected stitch.
- Continue programming in this manner.
- The following parameters can be altered separately for EACH STITCH within the combination:
  - Stitch Length
  - Stitch Width
  - Needle Position
  - Tension
  - Balance
  - Long Stitch
  - Pattern Extend 2-5x
  - Vertical Mirror Image
  - Horizontal Mirror Image
  - Securing Function
  - Sub-Divider 1 (640/200 only)
  - Sub-Divider 2 (200 only)
- The following parameters can be altered for ENTIRE STITCH COMBINATION (as one unit):
  - Motor Speed
  - Vertical Mirror Image

## Notes

# Memory – Basic Information – continued

## **activa & aurora**

### **Editing Memory**

Owner's manual page \_\_\_\_\_

- Programmed stitches can be deleted or overwritten.  
*activa 220/230PE/240 only: Changes can be made to the stitch properties prior to and/or after entering the stitch into memory.*
- Scroll to the stitch you wish to change or delete.
- Select the stitch you wish to replace it with and press the **mem** button. The new stitch is saved over the original one. Or – press **delete** and the stitch is cleared.

### **Saving and Leaving Memory**

Owner's manual page \_\_\_\_\_

- To save the contents, simply touch the center **mem** button. All entries are saved and the memory closes.
- All stored programs can be recalled at any time – even after the machine is turned off.

### **Memory Capacity**

Owner's manual page \_\_\_\_\_

- The total capacity is 30 spaces for **activa** models, 60 spaces for the **aurora 430**, and 90 for the **aurora 440QE** (meaning 30/60/90 individual stitch patterns)

### **Viewing Memory Contents**

Owner's manual page \_\_\_\_\_

- Use the arrows on either side of **mem** to scroll through memory.

## **artista 630/640/200**

### **Editing Memory**

Owner's manual page \_\_\_\_\_

- Touch screen to activate the stitch you wish to alter or delete (selected stitch will turn BLUE).
- Make desired alterations.

*Note: All alterations, insertions and deletions will always affect the area **above** the cursor.*

### **Saving and Leaving Memory**

Owner's manual page \_\_\_\_\_

#### **artista 200 only**

- Touch Multi-Function button. Select Save Combination; save stitch combination in a folder.
- All stored programs can be recalled at any time – even after the machine is turned off.

#### **artista 630/640 only**

- Touch the Save icon; save the stitch combination in a drawer.
- All stored programs can be recalled at any time – even after the machine is turned off.

### **Memory Capacity**

Owner's manual page \_\_\_\_\_

- Combi Mode
- 50 memory “drawers” hold stitch formations; each can be partitioned using memory sub-dividers.

### **Viewing Memory Contents**

Owner's manual page \_\_\_\_\_

- Method 1: Use arrows to scroll through Stitch Altering Area (SAA).
- Method 2: Touch Multi-Function button. Select Preview option. Touch Binocular symbol to see Sewing View. Stitch combination appears on screen, including all alterations. Touch **esc** to return to previous screen.

## Function Sampler

*This section is designed to demonstrate some of the stitch-altering and memory functions of your sewing machine. These functions enable a group of stitches to be selected, altered, manipulated, combined and/or stored.*

### Motor Speed

Owner's Manual pages \_\_\_\_\_

- Reduces sewing speed.
- Especially useful when stitching with delicate threads.

### Needle Stop Up/Down

Owner's Manual pages \_\_\_\_\_

- **activas:**
  - machine stops with needle up
  - press and release button to move needle down or up
  - press and hold button to set Needle Position down or up
- **auroras & artista 630/640**
  - press and release button to move needle down or up
  - press and hold button to set Needle Position down or up
- **artista 200**
  - press button; arrow appears on screen
  - machine stops with needle in up or down position
- **Foot Control (optional for activas)**
  - press heel; needle moves to opposite position
  - tap toe; machine sews one stitch

### Continuous Reverse

Owner's Manual pages \_\_\_\_\_

- **activas:** "double-click" Quick Reverse button
- **auroras:** press and hold Quick Reverse button; wait for beep
- **artistas:** press Continuous Reverse button

### Basting

Owner's Manual pages \_\_\_\_\_

- See exercise on pages 26-27

### Programming

Owner's Manual pages \_\_\_\_\_

- **activa & aurora:**
  - push button method
  - view by scrolling through memory bar one-by-one
- **artista:**
  - touch-screen method
  - view on-screen
  - stitches can be edited individually

## Notes



## Function Sampler - continued

<b>BERNINA®</b>	<b>220</b>	<b>230PE</b>	<b>240</b>	<b>430</b>	<b>440QE</b>	<b>630</b>	<b>640</b>	<b>200</b>
<b>Motor Speeds</b>	2	2	2	slide control	slide control	4	4	4
<b>Needle Up/Down Function</b>	Yes	Yes	Yes	Yes	Yes	Yes	Yes	Yes
<b>Needle Up/Down Foot Control</b>	(opt)	(opt)	(opt)	Yes	Yes	Yes	Yes	Yes
<b>Continuous Reverse</b>	Yes	Yes	Yes	Yes	Yes	Yes	Yes	Yes
<b>Basting/Long Stitch</b>	16/--	19/--	21/--	19/--	21/--	30/--	21/Yes	21/Yes
<b>Long Term Memory</b>	30 Spaces	30 Spaces	30 Spaces	60 Spaces	90 Spaces	Combi-Mode	Combi-Mode	Combi-Mode
<b>Pattern Begin</b>	--	--	--	Yes	Yes	Yes	Yes	Yes
<b>Pattern Repeat</b>	--	--	--	--	--	Yes	Yes	Yes
<b>Pattern Extend</b>	--	--	--	--	--	Yes	Yes	Yes
<b>Pattern End</b>	--	Yes	Yes	Yes	Yes	Yes	Yes	Yes
<b>Securing Function</b>	--	--	--	Yes	Yes	Yes	Yes	Yes
<b>Mirror Image – Side to Side</b>	--	--	Yes	Yes	Yes	Yes	Yes	Yes
<b>Mirror Image – Up &amp; Down</b>	--	--	--	--	--	--	Yes	Yes
<b>Balance Function</b>	(knob)	(knob)	(knob)	Yes	Yes	Yes	Yes	Yes
<b>Security Program</b>	--	--	--	--	--	Yes	Yes	Yes
<b>Stitch Counter</b>	--	--	--	--	--	--	--	Yes





## Function Sampler - continued

### Row 2 Needle Stop Adjustment

#### *activa*

- Stitch part of the row; stop. Press and hold the Needle Stop Up/Down button to lower the needle into the fabric. Press and hold the button again to raise the needle to its highest position.
- Continue sewing; stop again. Notice that the machine stops instantly, without coasting.

#### *aurora & artista*

- Engage the Needle Stop Up/Down function so needle will stop DOWN in the fabric. Sew part of the row; stop. Using the heel of your foot, tap base of foot control once to raise the needle.
- Continue sewing; stop again. Notice that the machine stops instantly, without coasting.
- When stitching is complete, touch the Needle Stop Adjustment symbol to engage the Needle Stop UP feature.

## Notes

### Row 3 Continuous Reverse

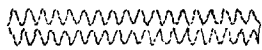

- Select running stitch #4; sew approximately 3". Using the Free Hand System (FHS), raise the presser foot and move the fabric to the left about 1/4".
- Select the Continuous Reverse function and continue stitching back to the beginning of the row. To access Continuous Reverse on the *activa* 220/230PE/240, "double-click" on the Quick Reverse button. On the *artista* 640 and 200, use the Automatic Thread Cutter to clip the threads.
- Reposition the fabric approximately 1" below the previous stitching. Touch the Continuous Reverse function again to deactivate it. Select stitch #1; sew about 3 - 4" more; stop.
- Engage the Continuous Reverse function again. Sew. Notice that the reverse stitches are the same length as the forward ones and that the machine tracks perfectly.
- Clip threads. Touch external CLR button to turn off the function.

## Function Sampler - continued

### Row 4

#### Basting with the Long Stitch Function

##### *activa, aurora & artista 630*

- Select a straight stitch; sew for approximately 1".
- Select the basting stitch if available; otherwise select a straight stitch and adjust the length to 5mm.
- Stitch a row of basting stitches. Before finishing the row, touch CLR to return stitch length to the normal setting (2-2.5mm). Finish sewing the row. This is an effective way to secure basting stitches.

##### *artista 640 & 200*

- Select stitch #1; sew for approximately 1".
- Engage the Long Stitch function and sew another 2 - 3"; adjust stitch length to 5mm and continue to sew.
- Before finishing the row of stitching, touch the external CLR button to cancel the alterations and turn off the Long Stitch function. Finish sewing the row. This is an effective way to secure basting stitches.

## Notes

# Function Sampler - continued

## Row 5

Pattern Begin, Pattern Repeat 1-9x, Pattern End



### **activa & aurora**

- Select the satin stitch scallop or satin stitch heart stitch:
  - 220\* ..... 32
  - 230PE\* ..... 48/46
  - 240 ..... 58/55
  - 430 ..... 88/76
  - 440QE ..... 102/99
- \* *Pattern Repeat is not available on the **activa** 220 & 230PE.*
- Begin sewing, then press the Pattern End button. Continue sewing; machine will stop when stitch pattern is complete. Move fabric forward about ½".
- Press the **mem** button to open Memory.
- Select pattern stitch and press **mem** ↓ to enter it into memory. Repeat two times for a total of three pattern stitches in Memory.
- Begin sewing; machine automatically starts at the beginning of the programmed stitch sequence.
- **activa:** Continue stitching. Press Pattern End; machine will automatically stop *when entire stitch sequence (3 scallops or hearts) is complete.*
- **aurora & artista 630:** Continue stitching. Press Pattern End; machine will automatically stop *at end of current stitch.* Press and hold Pattern End button until machine beeps. Sew; machine will automatically stop at end of entire stitch sequence.

### **artista**

- Select stitch #602. When a stitch is selected, the Pattern Begin function is automatically activated.
- Sew about 1½ stitch patterns; touch Pattern Begin, move fabric forward and stitch another 1½ patterns.
- Touch Pattern Begin and Pattern Repeat 3x. Move fabric slightly forward and stitch until machine stops. On **artista** 200, notice that while you stitch, the Pattern Repeat function counts down the number of pattern repeats left to sew.
- Begin sewing again; while stitching, touch the external Pattern End button (above Quick Reverse button on **artista** 200) or Pattern End function (located above sliding speed control on **artista** 640). When selected, Pattern End stops the machine at the end of the current stitch.
- Touch external CLR button to cancel the active functions.

## Notes

## Function Sampler - continued

### Row 6

#### Stitch Selection by Number, Securing Functions \* \*\*\*



#### **aurora**

- Select the star stitch:
  - 220\* ..... n/a
  - 230PE\* ..... n/a
  - 240\* ..... n/a
  - 430 ..... 126
  - 440QE ..... 155

\* These functions are not available on the **activa**.
- Attach Open Embroidery Foot #20 or Clear Foot #34 to machine.
- Engage Pattern End, pressing button until machine beeps. Sew; machine automatically stops after stitching one star.
- Engage Securing function and sew until machine stops. Three small stitches are sewn at beginning and end of motif. Rows of stitching can also be secured at beginning and end.
- Open **mem** and enter three star stitches. Make sure Pattern End and Securing functions are still engaged.
- Stitch; sew until machine stops. Note that securing stitches are sewn at the beginning of the first and end of the last/third stitch pattern.

#### **artista 200 only**

- Use Stitch Selection by Number to select #514; engage Pattern Repeat 1x.
- Attach Sideways Motion Foot #40 to **artista**. Sew. Sideways motion motifs must be guided carefully; do not allow fabric to turn while stitching.
- Engage Securing function and stitch motif again. Three small stitches are sewn at the beginning and end of the motif. Rows of stitching can also be secured at the beginning and end.

#### **All artistas:**

- Use Stitch Selection by Number to select #711; engage Pattern Repeat 4x and Securing function. Begin sewing. Before reaching end of row, stop and reengage the Securing function to secure stitching at the end of the row.
- Touch external CLR button to cancel active functions.

## Notes

## Function Sampler - continued

### Row 7

#### Mirror Image

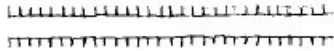

#### **activa 240 & aurora 430/440**

- Select the blanket stitch:  
220\* ..... 28  
230PE\* ..... 25  
240 ..... 41  
153QE ..... 50  
155 ..... 45

\* This function is not available on the **activa 220/230PE**.

- Sew one row across fabric.
- Engage Mirror Image and sew a second row next to the first.

#### **artista**

- Select #907; engage Pattern Repeat 1x. Stitch one turtle.
- Engage Vertical Mirror Image; sew one turtle.
- Disengage Vertical Mirror Image and engage Horizontal Mirror Image; sew one turtle.
- Engage both Vertical and Horizontal Mirror Image; sew one turtle.
- Touch external CLR button to cancel active functions.

## Notes

### Row 8 (**artista only**)

#### Pattern Extend 2-5x

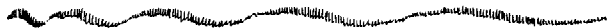

- Select #414; engage Pattern Repeat 1x. Sew one stitch pattern.
- Engage Pattern Extend 2x; sew one stitch pattern.
- Engage Pattern Extend 3x; sew one stitch pattern.
- Engage Pattern Extend 4x; sew one stitch pattern.
- Engage Pattern Extend 5x; sew one stitch pattern.

*Note: As the stitch pattern is lengthened, the stitch density is maintained. Your **artista** also limits the Pattern Extend capacity of stitches to ensure the best results for your sewing projects.*

- Touch the external CLR button to cancel active functions.

## Function Sampler - continued

### Row 9

#### Balance

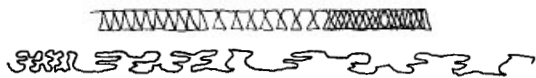

The Balance function is generally reserved for “fine tuning” the appearance of a stitch, as is sometimes required based on differences in fabrics and threads. Balance, however, can also be used as a creative tool to manipulate the look of a stitch. On the **artista** 630/640/200, for example, it can be used to alter the appearance of stiple stitch #327.

#### **activa & aurora**

- **activa:** Select double overlock stitch #8; stitch about 1½”. Adjust balance knob toward the “open” symbol; sew another 1½”. Adjust balance knob toward the “closed” symbol; sew 1½” more. Return balance knob to normal.
- **aurora:** Select double overlock stitch #8; sew about 1½”. Touch Balance button; use Needle Position buttons to adjust balance. Touch > to open stitch, < to close stitch. Adjust balance to 2; sew another 1½”. Adjust balance to -2; sew another 1½”. Return balance to normal.

#### **artista**

- Select stitch #327; sew.
- For a less compact stiple stitch, engage Pattern Extend 2x and adjust stitch length to 3mm. Sew. The Balance function can be used to alter the stitch even more. See Balance Function instructions below.
- In this exercise we want to use the Balance function to manipulate the appearance of a stitch, not to correct it. Adjust the balance as indicated in the box below for your **artista**. Touch OK and stitch.

## Notes

### Balance Function

#### **artista only**

Note: On **artista** models, balance affects only the selected stitch.

- Select Balance function. Two pictures appear on screen, showing the stitch in its original form. Using the Stitch Length knob, adjust the stitch image on the right side of the screen so it looks exactly like the stitch sample on your fabric. Touch OK; the **artista** 200 automatically corrects the stitch while sewing, calculating the proper balance to achieve the appearance of the original stitch (left screen).
- Sample: Turn Stitch Length knob until 5 is selected.



## Function Sampler - continued

### Row 10 (*artista* only)

#### Security Program (*artista* 630/640/200)



#### *artista* 640 & 200 only

- Insert a 1.0 Double needle into the *artista*. Thread with two colors, done in each needle eye.
- Select stitch #406 and Pattern Repeat 2x. Sew.
- Activate Security Program; select Double Needle 8.0. Touch OK. Sew.
- Repeat for Double Needle 6.0.

#### *artista* 630/640/200

- Continue the process above for the remaining Double Needle options: 4.0, 3.0, 2.0, and 1.0.
- When all Double Needle stitching is complete, touch the CLR button. Notice that this does NOT clear the Security Program.
- Turn your *artista* off. Turn back on. Notice that the Security Program is still active, and that a message appears on the screen to remind you of this.
- The Security Program can only be deactivated by selecting the Security Program and manually selecting the Single Needle and 9mm Stitch Plate options. Confirm changes by pressing OK.

## Notes

### Security Program

The Security Program of the *artista* 630/640/200 safely restricts the sideways motion of the needle when using Double, Triple, and Wing needles. The Security Program also restricts needle movement when using a Double Wing needle, or the Straight Stitch or 5mm Stitch Plates. When active, the Security Program affect ALL stitches, not just the selected stitch.



## Function Sampler - continued

### Row 11

#### Stitch Counter Seam (*artista 200 only*)

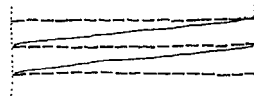

The Stitch Counter function of the **artista 200** is not for button-holes only. It can also be used to measure and stitch seams of a specific length. Useful for patchwork piecing and other seaming techniques.

- Mark a 3" seam length on the fabric by drawing 2 parallel lines, 3" apart. Select stitch #326. Select Stitch Counter function. Stitch along marked line. When desired length is sewn, press Quick Reverse. The seam is now programmed.
- Move the fabric back to the beginning of the seam. Sew. The **artista 200** automatically stops at the end of the programmed seam.
- Stitch the programmed seam again.
- A variety of stitches can be sewn using the Stitch Counter function. Several are found in the Practical stitch menu, such as Zigzag and Blindstitch. Others include the Blanket and Double Blanket stitches from the Quilting stitch menu.

## Notes

# Function Sampler

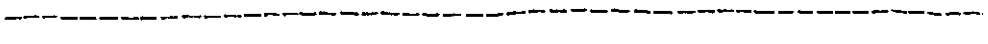
Row 1  
Motor Speed 

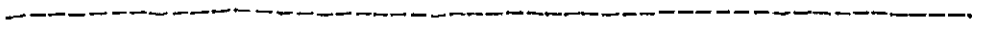
Row 2  
Needle Stop Up/Down 

Row 3  
Continuous Reverse 

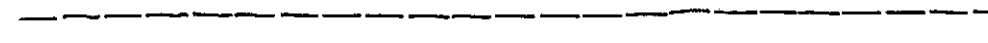
Row 4  
Basting/Long Stitch 

Row 5  
Pattern Begin/End 

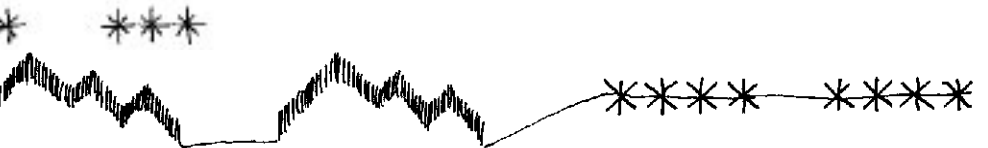
Row 6  
Select by Number & Securing Stitch 

Row 7  
Mirror Image 

Row 8  
Pattern Extend 

Row 9  
Balance 

Row 10 (artista only)  
Security Function 

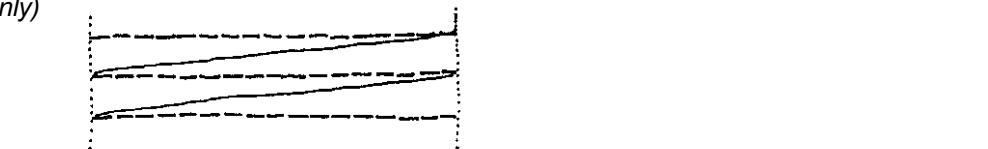
Row 11 (artista 200 only)  
Stitch Counter 



# Programming & Editing

Fabric ..... two pieces heavy muslin, each 6” x 8”  
 Stabilizer ..... tear-away as needed  
 Needle ..... 90/14 Embroidery or Sharp  
 Thread ..... 30 weight cotton embroidery  
 Presser Feet ..... Clear Foot #34/#34C  
 Stitches ..... as indicated  
 Needle Position ..... as indicated

## Notes

### Preparation

- Place muslin squares together. If needed, insert a layer of stabilizer between the layers.
- Draw four parallel lines on the fabric, about 1” apart.

### Row #1

- Select the Alphabet button.
- Program **BERNANA** and the date in block letters.
- Select Pattern End 1x (*not available on activa 220*) and stitch.

### Row #2

- Edit, changing the first “A” to an “I” to spell **BERNINA**.
- Select Pattern End 1x (*not available on activa 220*) and stitch.

### Row #3 (*not activa 220*)

- Clear memory.
- Program the indicated stitch sequence.
- Engage Pattern End 1x and the Securing function (if available).
- Stitch.

### Row #4 (*not activa 220/230PE*)

- Clear memory.
- Select the heart stitch; enter into memory one time.
- Engage mirror image and enter the heart stitch into memory again (one time).
- Sew a row across the fabric.



# Programming & Editing Sampler

Row 1

BERNINA 10-1-98

Row 2

BERNINA 10-1-98

Row 3

\*~~~~~\*

Row 4

~~~~~

| <b>BERNINA®</b>     | <b>220</b> | <b>230PE</b> | <b>240</b> | <b>430</b> | <b>440QE</b> | <b>630</b> | <b>640</b> | <b>200</b> |
|---------------------|------------|--------------|------------|------------|--------------|------------|------------|------------|
| <b>Row #3</b>       | #50, 1x    | #64, 1x      | #84, 1x    | #126, 1x   | #155, 1x     | #711, 1x   | #711, 1x   | #711, 1x   |
| <b>Stitch</b>       | #43, 3x    | #65, 3x      | #88, 3x    | #130, 1x   | #159, 1x     | #717, 1x   | #717, 1x   | #717, 1x   |
| <b>Combination</b>  | #50, 1x    | #64, 1x      | #84, 1x    | #126, 1x   | #155, 1x     | #711, 1x   | #711, 1x   | #711, 1x   |
| <b>Row #4</b>       | --         | --           | #55        | #76        | #99          | #413       | #413       | #413       |
| <b>Heart Stitch</b> |            |              |            |            |              |            |            |            |



# Memory Sampler

|                       |                             |
|-----------------------|-----------------------------|
| Fabric .....          | heavy muslin, 8" x 8"       |
| Stabilizer .....      | tear-away as needed         |
| Needle .....          | 90/14 Embroidery or Sharp   |
| .....                 | Wing                        |
| .....                 | Double/Twin                 |
| Thread .....          | 30 weight cotton embroidery |
| Presser Feet.....     | Clear Foot #34/#34C         |
| Stitches.....         | as indicated                |
| Needle Position ..... | as indicated                |

## Notes

### Preparation

- Before stitching this exercise, read the information completely and stitch the Programming & Editing exercise from the previous page.
- Sew out stitches on test muslin first.
- If needed, insert a layer of stabilizer between the layers of muslin.
- Draw guide lines before sewing rows of stitches.
- Sampler can be laid out as shown, or you may arrange it as desired.
- Add or delete rows as needed to create the desired look.

### Row #1

- Insert Wing needle. Sew a row of stitch indicated in chart.
- Note the hemstitch effect created by the "wings" of the needle.

### Row #2

- Change back to single needle. Program sequence: leaf 1x, star 3x, leaf 1x. Sew one repeat.

### Row #3

- Program the indicated stitch sequece. Sew one group.

### Row #4

- Insert Double needle. Sew a row of stitch indicated in chart.

### Row #5

- Program name and date in Block letters. Sew one group.

### Row #6 (not *activa* 220/230PE)

- Program two hearts, engaging Mirror Image for the second one. Sew a row of alternating hearts across fabric.

### Row #7 (not *activa* 220/230PE)

- Program as follows: star 1x, engage Mirror Image, leaf 1x, clear Mirror Image, leaf 1x, disengage Mirror image, leaf 1x, star 1x.

# Memory Sampler

|                             |  |  |
|-----------------------------|--|--|
| Row 1<br>with Wing Needle   |  |  |
| Row 2                       |  |  |
| Row 3                       |  |  |
| Row 4<br>with Double Needle |  |  |
| Row 5                       |  |  |
| Row 6                       |  |  |
| Row 7                       |  |  |

| <b>BERNINA®</b>                        | <b>220</b> | <b>230PE</b> | <b>240</b> | <b>430</b>   | <b>440QE</b> | <b>630</b>   | <b>640</b>   | <b>200</b>   |
|----------------------------------------|------------|--------------|------------|--------------|--------------|--------------|--------------|--------------|
| <b>Row #1</b><br>(entredeux/honeycomb) | #41        | #59          | #76        | #118         | #147         | #701         | #701         | #701         |
| <b>Row #2</b><br>(leaf/star)           | #43<br>#50 | #65<br>#64   | #88<br>#84 | #126<br>#130 | #155<br>#159 | #605<br>#711 | #605<br>#711 | #605<br>#711 |
| <b>Row #3</b><br>(star/check)          | #50<br>#35 | #64<br>#50   | #84<br>#51 | #126<br>#69  | #155<br>#92  | #711<br>#405 | #711<br>#405 | #711<br>#405 |
| <b>Row #4</b><br>(feather)             | #45        | #28          | #44        | #53          | #48          | #332         | #332         | #332         |
| <b>Row #6</b><br>(hearts)              | --         | --           | #55        | #76          | #99          | #413         | #413         | #413         |
| <b>Row #7</b><br>(star/scallop)        | --<br>--   | --<br>--     | #84<br>#29 | #126<br>#39  | #155<br>#79  | #711<br>#122 | #711<br>#122 | #711<br>#122 |



# Buttonhole Memory

Fabric ..... heavy flannel, 6" x 8"  
 Stabilizer ..... 1" x 8" strip of Poly Mesh stabilizer  
 Needle ..... 90/14 Embroidery or Sharp  
 Thread ..... 30 weight cotton embroidery  
 Presser Feet ..... Automatic Buttonhole Foot with Slide #3A/C  
 Buttonhole ..... as indicated

## Notes

### Short Term Memory

- Fold fabric in half to 3" x 8"
- Space buttonhole markings evenly across the fabric.
- Select the standard buttonhole (see chart) and attach Automatic Buttonhole Foot with Slide #3A/C to the machine.
- Sew the first bead; stop at the desired length and press the Quick Reverse button.
- The machine will automatically sew the rest of the buttonhole and stop at the end after sewing a few securing stitches.
- After the buttonhole is complete, the word **auto** appears on the screen, indicating that the buttonhole is programmed in short term memory.
- All subsequent buttonholes will be sewn in this programmed size until the machine is turned off or a different buttonhole is programmed over this one.
- Sew a second buttonhole.

### Long Term Memory (*activa* 220/230/240 & *aurora* 430/440)

*Note: Only one buttonhole may be saved in Long Term Memory on the **activa** 220/230/240 and **aurora** 430/440.*

- Press **mem** (after the buttonhole has been programmed as above).
- To test, turn machine off and wait 60 seconds. Turn machine back on.
- Select the standard buttonhole and press the **mem** button.
- Sew the buttonhole on the third line.

*Note: To clear a saved buttonhole, a new one must be programmed over the previous one.*

### Long Term Memory (*artista* 630/640/200 only)

- Select the Stitch Altering Area (SAA). Select Save Settings.
- To test, turn machine off and wait 60 seconds. Turn machine on.
- Select the buttonhole, touch the on-screen measuring icon, press OK.
- Sew the buttonhole on the third line.

*Note: To clear a saved buttonhole, a new one must be programmed over the previous one.*

*Note: All exercises in the rest of this workbook are for **artista** sewing machines only.*

# Buttonhole Memory Sample

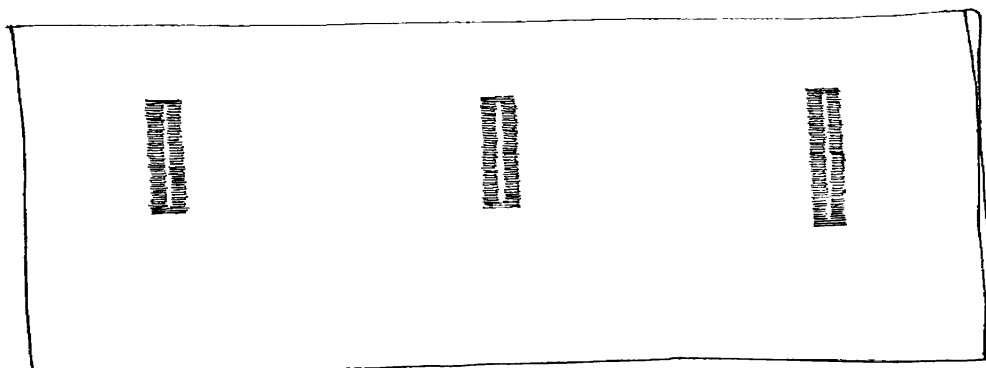

|                            |            |              |            |            |              |            |            |            |
|----------------------------|------------|--------------|------------|------------|--------------|------------|------------|------------|
| <b>BERNINA®</b>            | <b>220</b> | <b>230PE</b> | <b>240</b> | <b>430</b> | <b>440QE</b> | <b>630</b> | <b>640</b> | <b>200</b> |
| <b>Standard Buttonhole</b> | #10        | #10          | #10        | #10        | #10          | #51        | #51        | #51        |





*artista 630/640/200 only*

## Memory/Combi Mode

Fabric ..... heavy muslin, 12" x 12"  
 Stabilizer ..... tear-away as needed  
 Needle ..... 90/14 Sharp or Embroidery  
 Thread ..... 30 weight cotton embroidery  
 Presser Foot ..... Reverse Pattern Foot #1/1C or  
 ..... Clear Foot #34/34C  
 Stitch ..... as indicated  
 Needle Position ..... center

### Notes

The following parameters can be altered separately for EACH STITCH within a combination:

|                           | 630 | 640 | 200 |
|---------------------------|-----|-----|-----|
| • Stitch Length           | yes | yes | yes |
| • Stitch Width            | yes | yes | yes |
| • Needle Position         | yes | yes | yes |
| • Tension                 | n/a | yes | yes |
| • Balance                 | yes | yes | yes |
| • Long Stitch             | --- | yes | yes |
| • Pattern Extend 2-5x     | yes | yes | yes |
| • Vertical Mirror Image   | yes | yes | yes |
| • Horizontal Mirror Image | yes | yes | yes |
| • Securing Function       | yes | yes | yes |
| • Sub-Divider 1           | --- | yes | yes |
| • Sub-Divider 2           | --- | --- | yes |

The following parameters can be altered for the ENTIRE STITCH COMBINATION (as one unit):

- Motor Speed
- Vertical Mirror Image

*artista 630/640/200 only*

## Memory/Combi Mode continued:

### Preparation

**all artista sewing systems:** Using a spray adhesive such as 505, adhere the stabilizer to the muslin. Mark six parallel lines on the fabric, approximately 1½” apart.

### Row 1

#### Creating and Saving a Stitch Combination

630:  640 & 200: 

- Touch the Combi Mode symbol. The Stitch Altering Area (SAA) appears, ready for stitch input.
- Select stitch #120 (*artista* 630) or #143 (*artista* 640 & 200). The stitch is automatically entered into the Stitch Altering Area. Notice that the background of the selected stitch is BLUE and that there is a RED cursor (dotted line) along the lower edge of the selected stitch.
- Select stitch #120/145 again. Notice that the first stitch is not active.
- To edit stitches in Combi Mode, simply touch the screen to activate the desired stitch (the selected stitch will turn BLUE), then select the alterations.
- With the second #120/145 selected, engage the Horizontal Mirror Image Function.

#### *artista 630 & 640*

- Touch the Multi-Function icon (eyeglasses icon), Select Save Combination (flashing floppy disk / file drawer icon); save combination.
- Engage Pattern Repeat 4x. Sew.

#### *artista 200*

- Touch the Multi-Function button, select Save Combination. Save this combination in a folder.
- Engage Pattern Repeat 4x. Sew.

## Notes

### Mirror Image Icons - Function Bar

#### *artista 630/640/200*

Horizontal  
(Up/Down)



Vertical Mirror Image  
(Right/Left)





*artista 630/640/200 only*

## Memory/Combi Mode continued:

### Row 2

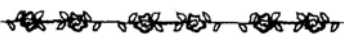
#### Inserting Stitches - Exercise A

630:  640/200: 

- Your previous stitch combination should still be visible in the Stitch Altering Area.
- Touch the first stitch pattern (it should turn BLUE). You will be inserting a stitch in front of this one. Use the UP scroll arrow to move the cursor to the TOP of the first stitch pattern. *Note: All alterations, insertions, and deletions always affect the area **above** the cursor.*
- Select stitch #137; it appears above the first stitch (#120/145). With stitch #137 selected, engage the Horizontal Mirror Image function.
- Scroll to the end of the combination, or touch the last stitch pattern. Select stitch #137; it will be inserted into the stitch combination.

#### *artista 630 & 640*

- Touch the Save icon. Save this combination in an empty folder.
- Engage Pattern Repeat 3x.
- Sew.

#### *artista 200*

- Touch the Multi-Function icon, select Save Combination. Save this combination in a different folder than Row 1.
- Engage Pattern Repeat 3x.
- Sew.

## Notes

*artista 630/640/200 only*

## Memory/Combi Mode continued:

Row 3

Inserting Stitches - Exercise B

630:  640/200: 

- The previous stitch combination (Row 2) should still be visible in the Stitch Altering Area (SAA).
- Insert stitch #401 at the beginning of the combination. Insert stitch #401 two times at the end of the combination.

### *artista 630 & 640*

- Touch the Save icon. Save this combination in an empty folder.
- Engage Pattern Repeat 2x; sew.
- This combination isn't quite as pretty as one might like, so it will be altered for Row 4.

### *artista 200*

- Touch Multi-Function button; select Save Combination. Save this combination in a different folder.
- Engage Pattern Repeat 2x; sew.

## Notes

*artista 630/640/200 only*

## Memory/Combi Mode continued:

### Row 4 - Altering and Deleting Stitches - Exercise A

630:  640/200: 

Select the first stitch in the combination, then touch Delete.

Select the next to last stitch, #401. Engage the Horizontal Mirror Image function.

Save this combination in the same memory bank as Row 3; it will overwrite the previous combination.

Engage Pattern Repeat 2x; sew. While the second repeat is stitching, touch Pattern End as the second leaf is sewn; the **artista** will stop at the end of the leaf. *Note: The Pattern End button signals your **artista** to complete the current stitch pattern and then stop.*

*Note: When a stitch combination is being sewn, selecting the Pattern End function will stop the machine at the end of the current stitch, not at the end of the current combination.*

Notes

*artista 630/640/200 only*

## Memory/Combi Mode continued:

### Row 5 - Inserting Stitches - Exercise C

630: 

640/200: 

- Touch the File Drawer symbol. Select an empty folder. Combine the following stitches:
  - stitch #740, one time
  - stitch #751, one time
  - stitch #744, one time
  - stitch #751, 1x
  - stitch #740, 1x

#### **artista 630 & 640**

- Touch the Multi-Function icon; the Preview screen opens. Touch Escape.
- Touch the Save icon. Save combination in an empty folder.
- Engage Pattern Repeat 1x; sew.

#### **artista 200**

- Touch Multi-Function symbol; select the Preview option. Touch the Binocular symbol to access the second level of Preview, the Sewing View. Touch ESC.
- Touch the Multi-Function button. Select the Save Combination option. Save in a new folder.
- Engage Pattern Repeat 1x; sew.

## Notes

*artista 630/640/200 only*

## Memory/Combi Mode continued:

### Row 6 - Altering and Deleting Stitches - Exercise B

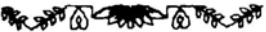
630: 

640/200: 

- The previous stitch combination should still be visible in the Stitch Altering Area (SAA).
- Touch the Multi-Function symbol. Select the Mirror Image Combination Option.

#### *artista 630 & 640*

- Touch Multi-Function icon; the Preview option appears on screen. Your stitch combination appears on-screen as a mirror image of the original combination. Touch ESC.
- Touch the Save icon. Save combination in an empty folder.
- Engage Pattern Repeat 1x; sew.

#### *artista 200*

- Touch Multi-Function symbol; select the Preview option. Touch the Binocular symbol to access the second level of Preview, the Sewing View. Your stitch combination appears on-screen as a mirror image of the original combination. Touch ESC.
- Touch the Multi-Function button. Select the Save Combination option. Save Row 6 in a new folder.
- Engage Pattern Repeat 1x; sew.

Notes

# Memory/Combi Mode Sampler

*artista 630*

*artista 640 & 200*

Row 1  
*Creating & Saving a Stitch Combination*

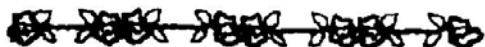

Row 2  
*Inserting Stitches – Exercise A*

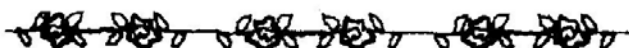

Row 3  
*Inserting Stitches – Exercise B*



Row 4  
*Altering & Deleting Stitches – Exercise A*



Row 5  
*Inserting Stitches – Exercise C*

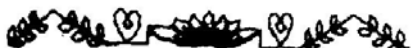

Row 6  
*Altering & Deleting Stitches – Exercise B*







*artista 640/200 only*

# Memory/Sub-Divider 1 Sampler

Fabric ..... heavy muslin, 6" x 12"  
Stabilizer ..... tear-away  
Needle ..... 90/14 Universal  
Thread ..... 30 weight cotton embroidery  
Presser Foot ..... Reverse Pattern Foot #1/1C  
Stitch ..... decorative stitches as indicated  
Needle Position ..... center

## Notes

- Combine the following stitches in Combi Mode:
  - stitch #137 + Horizontal Mirror Image
  - stitch #145
  - stitch #145 + Horizontal Mirror Image
  - stitch #137
  - Sub-Divider 1
- After the Sub-Divider 1, enter the following stitches:
  - stitch #448 + Horizontal AND Vertical Mirror Image
  - stitch #137 + Horizontal Mirror Image
  - stitch #145
  - stitch #145 + Horizontal Mirror Image
  - stitch #137
  - stitch #448
  - Sub-Divider 1
- Save this stitch combination.

*Instructions for sewing this sample are on pages **ADD NEW #S.***

# Memory/Sub-Divider 1 Sampler

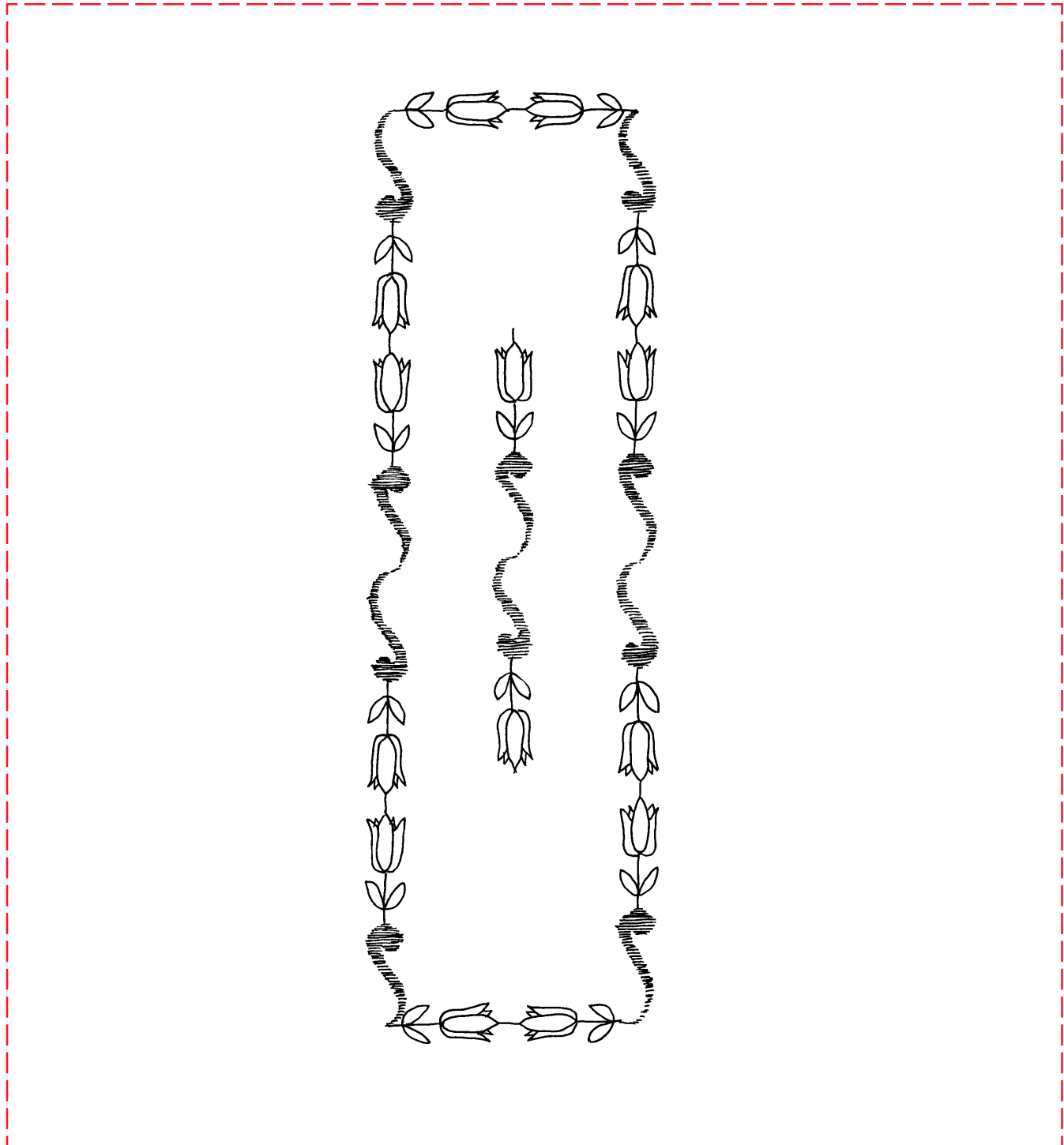

*artista 640/200 only*

## Memory/Sub-Divider 1 Sampler continued:

### Stitching Outer Rectangle

- Using a temporary spray adhesive, bond the stabilizer to the muslin.
- Scroll to select the first section of the saved stitch combination. Activate Pattern Begin and Pattern Repeat 1x.
- Sew; at the end of the stitching, stop down on the heel of the foot control to move the needle into the down position. Pivot 90°, then use the foot control to move the needle to the up position.
- Scroll to the second section of the stitch combination. Activate Pattern Begin and Pattern Repeat 2x. Sew; the **artista** will automatically stop after the second repeat. *Note: When Sub-Divider 1 is used, the artista will stitch multiples of ONLY the selected section.* When the second repeat is complete, use the foot control to move the needle to the down position. Pivot 90°, then use the foot control to move the needle to the up position.
- Scroll to the first section of the stitch combination. Activate Pattern Begin and Pattern Repeat 1x. Sew; at the end of the stitching, move the needle to the down position. Pivot 90°, then use the foot control to move the needle to the up position.
- Scroll to the second section of the combination. Activate Pattern Begin and Pattern Repeat 2x. Sew. This completes the stitching of the rectangle.

## Notes

*artista 640/200 only*

## Memory/Sub-Divider 1 Sampler continued:

### Stitching Center Motif

- The center motif is about 4" long. Draw a line through the center of the stitched rectangle to use as a guide.
- Select the Multi-Function button. Select the Preview option. Scroll to move the cursor just to the right of the *second* tulip in the *second* section of the stitch combination. Notice that every stitch in the combination is numbered.
- Select the 9th stitch (tulip). When the stitch is selected, the Preview screen auto-matically closes. The *artista* will begin stitching at the beginning of stitch nine (unless the cursor is moved again).
- Sew; the *artista* will stitch the end of the combination and automatically begin sewing it a second time.
- Sew, watching stitching. After the tulip begins stitching, press the Pattern End button on the front of the *artista*; sewing will stop at the end of the tulip.

### Notes

*artista 630/640/200 only*

## Setup Program

The Setup Program allows personalization of your sewing system to reflect your sewing style, needs, and preferences. To access, press the external Setup button.

### Display > Brightness & Display > Contrast

- adjust the appearance of the screen for the lighting conditions in your sewing area

### Display > Welcome Text

- change greeting

### Sewing Setting > Sewing Light (*artista 200 only*)

- turn sewing light off/on

### Sewing Settings > Motor Speed

- adjust the overall sewing speed of your sewing system  
*Note: the artista has a separate motor speed screen for embroidery; to access, touch the Embroidery Settings symbol*

### Sewing Settings > Thread Tension (*artista 640 & 200 only*)

- adjust the overall tension setting of your sewing system  
*Note: the artista 200 has a separate tension screen for embroidery; to access, touch the Embroidery Settings symbol*

### Customize Favorite Function (*artista 200 only*)

- assign function of your choice to the Favorite Function button

### Touch > Calibrate

- calibrate the touch screen of your sewing system

### Software & Language

- access information on the software version installed in your sewing machine and embroidery module

## Notes

### Sewing Tension

(*artista 640 & 200 only*)

The tension of BERNINA® sewing machines is factory set for the best “all around” results using Mettler polyester Metrosene thread in the needle and bobbin. If you regularly use other types of thread, you may find it useful to adjust your tension settings using the Thread Tension Adjustment in the Setup Screen.

*artista 640/200 only*

## Setup Program - continued

### Emb Set > Adjust Ref Position

- adjust the reference point of the embroidery module

### Emb Set > Auto Thread Cutter (*artista 640 & 200 only*)

- turn embroidery thread cutter off/on

### Messages & Audio Signals

- turn audio signals off/on
- choose from a range of signals for each function:
  - Select Stitch
  - Select Function
  - Upper Thread Control
  - Lower Thread Control (*artista 640 & 200 only*)
  - Feed Dog Position
  - Presser Foot Position
  - Bobbin Winder
  - Embroidery Finished
  - Thread Cutter (*artista 640 & 200 only*)
  - Threader (*artista 200 only*)

### Stitch Altering Area

- permanently set stitches to suit your personal preferences  
*Note: to access, touch SAA; pop-up menu appears on screen*
- the following settings can be modified permanently:
  - Stitch Length
  - Stitch Width
  - Needle Position
  - Tension (*artista 640 & 200 only*)
  - Balance
  - Vertical Mirror Image
  - Horizontal Mirror Image
  - Pattern Extend 2-5x
  - Long Stitch (*artista 640 & 200 only*)
  - Pattern Repeat 1-9x

## Notes



(*artista* 630/640/200 only)

## Setup Program - continued

### Personal Program Button

- create a personal menu of stitches, including your favorite settings, all adjusted to suit to your personal preferences:
  - Stitch Length
  - Stitch Width
  - Needle Position
  - Tension (*artista* 640 & 200 only)
  - Balance
  - Vertical Mirror Image
  - Horizontal Mirror Image
  - Pattern Extend 2-5x
  - Long Stitch (*artista* 640 & 200 only)
  - Pattern Repeat 1-9x

### Portal Provider Settings (*artista* 200 only)

- set up a phone connection for optional *artista* 200 modem
- allows access to a special *artista* 200 portal for News, Downloads, and Tutorials

### Return to Basic Settings

- returns all settings -- sewing and/or embroidery -- to the original factory settings

### esc & Leave Setup

- closes the Setup Screen without making changes
- returns to previously selected screen

Notes

*artista 200 only*

## Tutorial

*Note: The **artista** 630 & 640 feature an embroidery Tutorial which acts as an “on-line” reference for a variety of embroidery topics. See the Mastering Your BERNINA Embroidery Module Workbook for more information.*

### **artista 200:**

*The **artista** Tutorial acts as an “on-line” manual with instructions for a variety of sewing and embroidery topics.*

- Press the external **T** button
- Select the desired category from those listed:
  - Threading
  - Sewing Techniques
  - Buttonholes
  - Peripherals
  - Embroidery
  - Free Hand System (FHS)
  - Trouble Shooting
  - Presser Feet
  - Needles
- Information is displayed in the form of text, color diagrams, and video clips. *Note: Attach the BERNINA® CD-ROM drive to your **artista** and insert the Tutorial CD to access additional video clips.*

## Notes



*artista 200 only*

## Creative Consultant

The *artista 200* sewing system has an internal “sewing consultant” that provides a wide range of sewing information and instructions.

- Press the external **C** button.
- Select the appropriate fabric type from the menu of lightweight, medium weight, and heavyweight fabrics.
- Select the desired sewing technique:
  - Seaming
  - Overcasting
  - Edgestitching
  - Blindhem
  - Buttonhole
  - Zipper
  - Invisible Zipper
  - Decorative Work
  - Machine Quilting
  - Freemotion Work
  - Applique
  - Sideways Motion

## Notes

*artista 630/640/200*

## Creative Consultant - continued

- The Creative Consultant displays the following recommendations:
  - Presser Foot & Alternates
  - Needle & Alternates
  - Presser Foot Pressure
  - Stabilizer
  - Feed Dog Up/Down
  - Additional Accessories
  - Additional Comments
  - Tutorial Links
- After selecting the appropriate fabric and technique, press OK; the *artista* 200 selects and adjusts the recommended stitch and settings for:
  - Stitch Length
  - Stitch Width
  - Needle Position
  - Tension
  - Balance
  - Needle Stop Up/Down
  - Maximum Sewing Speed

**Notes**



## **Class 6**

# **Product Reference List**

## **Stitch Manipulations**

- Feet-ures*, Volumes 1 and 2
- BERNINA® Buttonhole Foot with Slide #3A/C
- BERNINA® Open Embroidery Foot #20 *or*
- BERNINA® Open Embroidery Foot #20C
- BERNINA® Clear Foot #34 *or*
- BERNINA® Clear Foot #34/C

- BERNINA® Ironing System
- BERNINA® Iron
- 505 Temporary Spray Adhesive
- Thread Stand

### Threads

- 30 weight cotton embroidery thread
- Mettler Gimp cord *or* YLI Pearl Crown Rayon

### Needles

- Microtex Sharp
- Embroidery



# Class 7

## Directional Stitching

### Class Overview

#### Directional Stitching

- 1 Directional Stitching
- 2 Freeform Directional Stitching
- 3 All-Over Directional Stitching
- 4 Trailing Tulip Vines
- 5 Monogram
- 6 Scalloped Edge
- 7 Stacked Scallop Edge
- 8 Directional Quilting
- 9 Directional Baubles

This class is formatted for owners  
of the following model of  
BERNINA® sewing machines:  
• *artista* 200



## Directional Stitching

(*artista 200* only)

|                       |                                |
|-----------------------|--------------------------------|
| Fabric .....          | firm fabric, 6" x 6"           |
| Stabilizer .....      | heavyweight tear-away, 6" x 6" |
| Needle .....          | 90/14 Embroidery               |
| Thread .....          | 30 weight cotton embroidery    |
| Presser Foot .....    | Sideways Motion Foot #40C      |
| Stitch .....          | directional zigzag             |
| Needle Position ..... | center                         |

### Notes

Mark the center of the square of fabric. Place stabilizer behind fabric, bonding with a light application of HRFive adhesive.

Starting at the center of the fabric, stitch all 16 directions using the preprogrammed directional zigzag stitch #40. Note the changes in the stitch formation that occur with changes in sewing direction.

Trim and mount the sample.

# Directional Stitching Sample

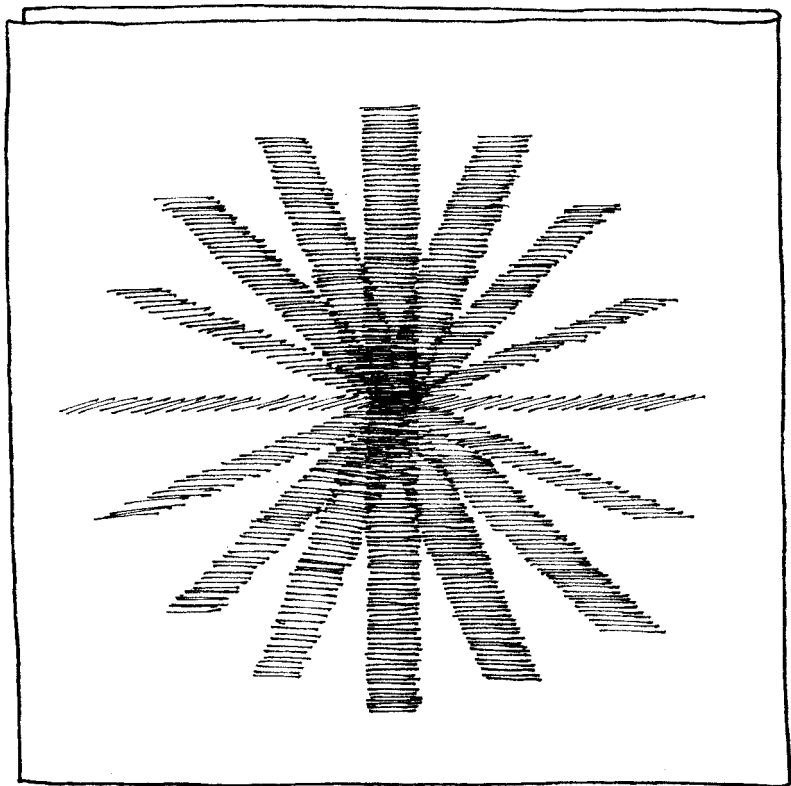



# Free-Form Directional Stitching

*(artista 200 only)*

|                       |                                |
|-----------------------|--------------------------------|
| Fabric .....          | firm fabric, 6" x 6"           |
| Stabilizer .....      | heavyweight tear-away, 6" x 6" |
| Needle .....          | 90/14 Embroidery               |
| Thread .....          | 30 weight cotton embroidery    |
| Presser Foot .....    | Sideways Motion Foot #40C      |
| Stitch .....          | directional straight stitch    |
| .....                 | directional zigzag stitch      |
| Needle Position ..... | center                         |

## Notes

Select directional straight stitch #39, then choose a direction from the compass template that appears on the screen. Stitch 1" to 2".

Select a different direction. Stitch a couple inches.

Select another direction; stitch.

Continue selecting directions and stitching.

Repeat using directional zigzag stitch #40.

*Note: The **artista** 200 can change directions while stitching; the machine does not have to be stopped first.*

# Free-Form Directional Stitching Sample

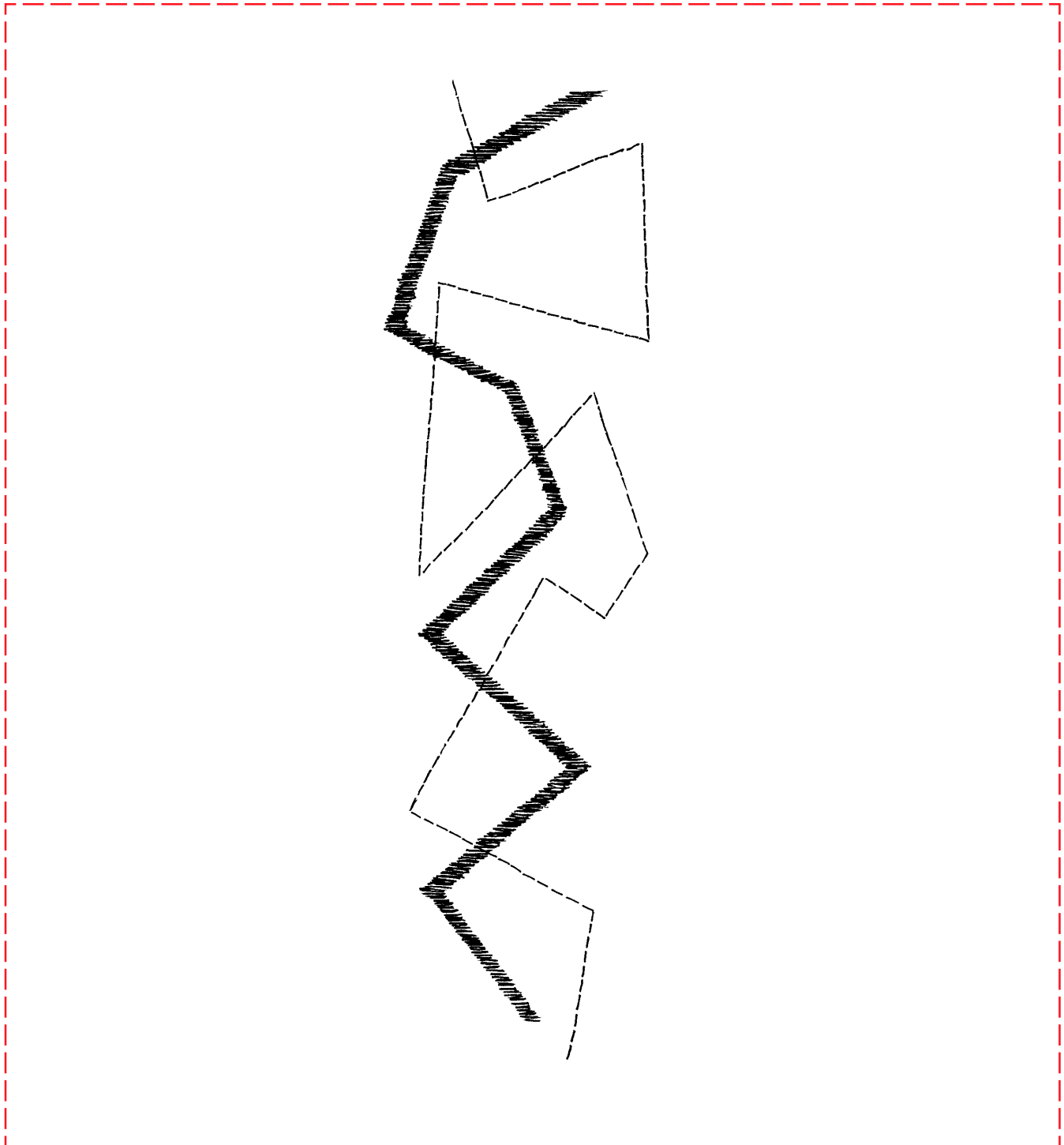





# All-Over Directional Stitching

*(artista 200 only)*

|                       |                             |
|-----------------------|-----------------------------|
| Fabric .....          | chamois, 8" x 12"           |
| Stabilizer .....      | Aqua Film, 8" x 12"         |
| Needle .....          | 90/14 Embroidery            |
| Thread .....          | 30 weight cotton embroidery |
| Presser Foot .....    | Sideways Motion Foot #40C   |
| Stitch .....          | directional straight stitch |
| Needle Position ..... | center                      |

## Notes

Place stabilizer behind fabric, bonding with a light application of 505 temporary adhesive. Fold fabric/stabilizer in half to 4" x 12". Mark a large + shape on the fabric as a reference/guideline.

Program the following stitches in Combi Mode:

- #217, two times
- Insert stitch #39, direction 6, 4x between the two #217s
- Insert stitch #39, direction 10, 4x after the second #217

Save the stitch combination.

Stitch from one end of the fabric to the other, guiding fabric so that the + stays parallel and perpendicular to the presser foot.

Stitch additional rows parallel to the first row, creating an allover pattern on the fabric.

# All-Over Directional Stitching Sample

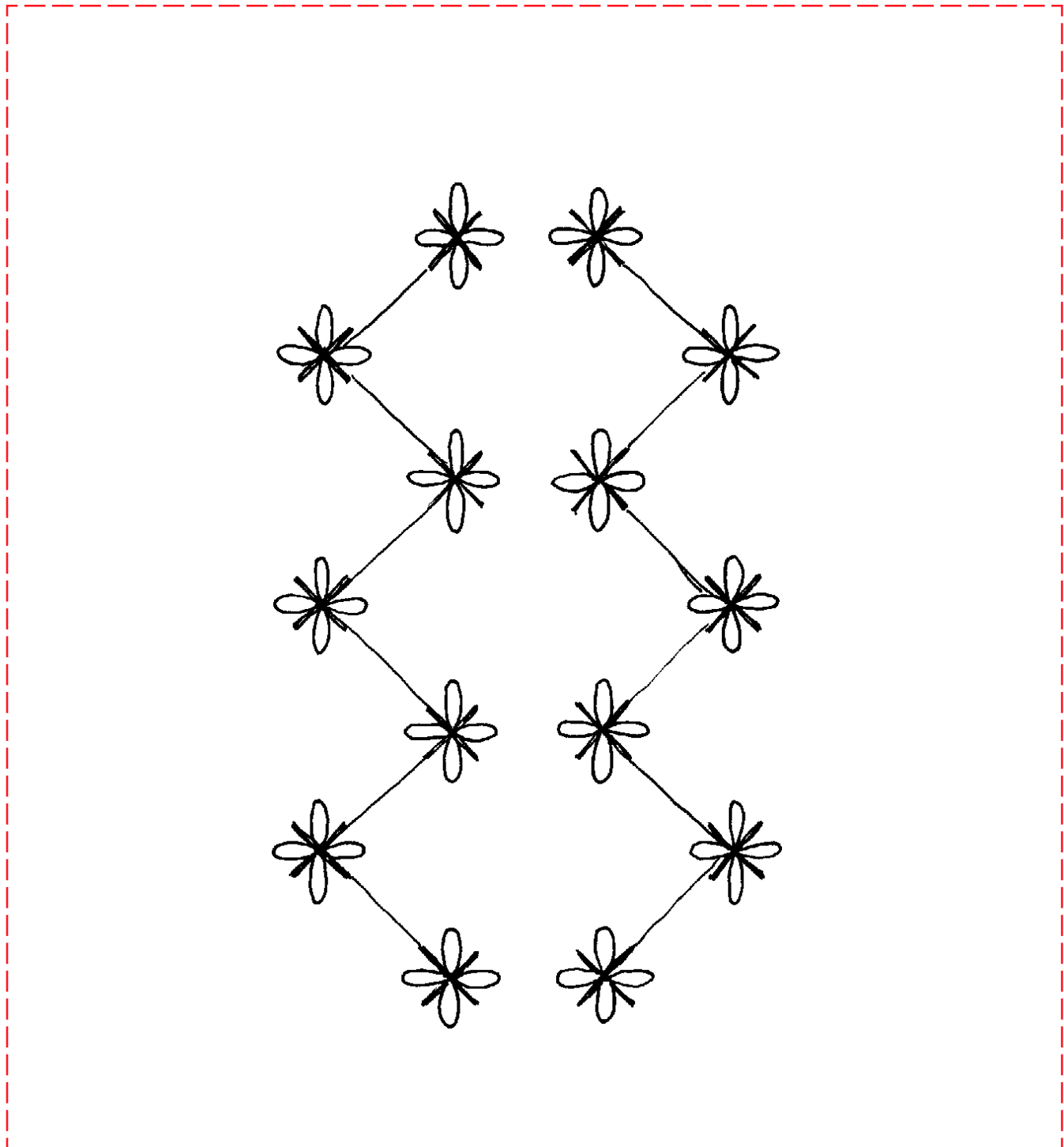



# Trailing Tulip Vines

(*artista* 200 only)

|                       |                                 |
|-----------------------|---------------------------------|
| Fabric .....          | chamois, 8" x 12"               |
| Stabilizer .....      | heavyweight tear-away, 8" x 12" |
| Needle .....          | 90/14 Embroidery                |
| Thread .....          | 30 weight cotton embroidery     |
| Presser Foot .....    | Sideways Motion Foot #40C       |
| Stitch .....          | as indicated                    |
| Needle Position ..... | center                          |

## Notes

Place stabilizer behind fabric, bonding with a light application of HRFive spray adhesive.

Program the following stitches in Combi Mode:

- stitch #137\* + Horizontal Mirror Image
- stitch #145
- stitch #39, direction 6 - 1x
- stitch #145 + Horizontal Mirror Image
- stitch #137
- stitch #39, direction 10 - 1x
- stitch #145 + Horizontal Mirror Image
- stitch #137
- stitch #39, direction 6 - 1x
- stitch #137 + Horizontal Mirror Image
- stitch #145
- stitch #39, direction 10 - 1x

Save the stitch combination.

Stitch from one end of the fabric to the other, guiding fabric so that the "+" stays parallel and perpendicular to the presser foot.

Stitch additional rows of this stitch combination, scrolling through the stitches to start at different points.

*Note: Some adjustments to stitch combination formulas may be necessary depending on the fabric, thread, and stabilizer used to create the stitch sample.*

# Trailing Tulip Vines Sample

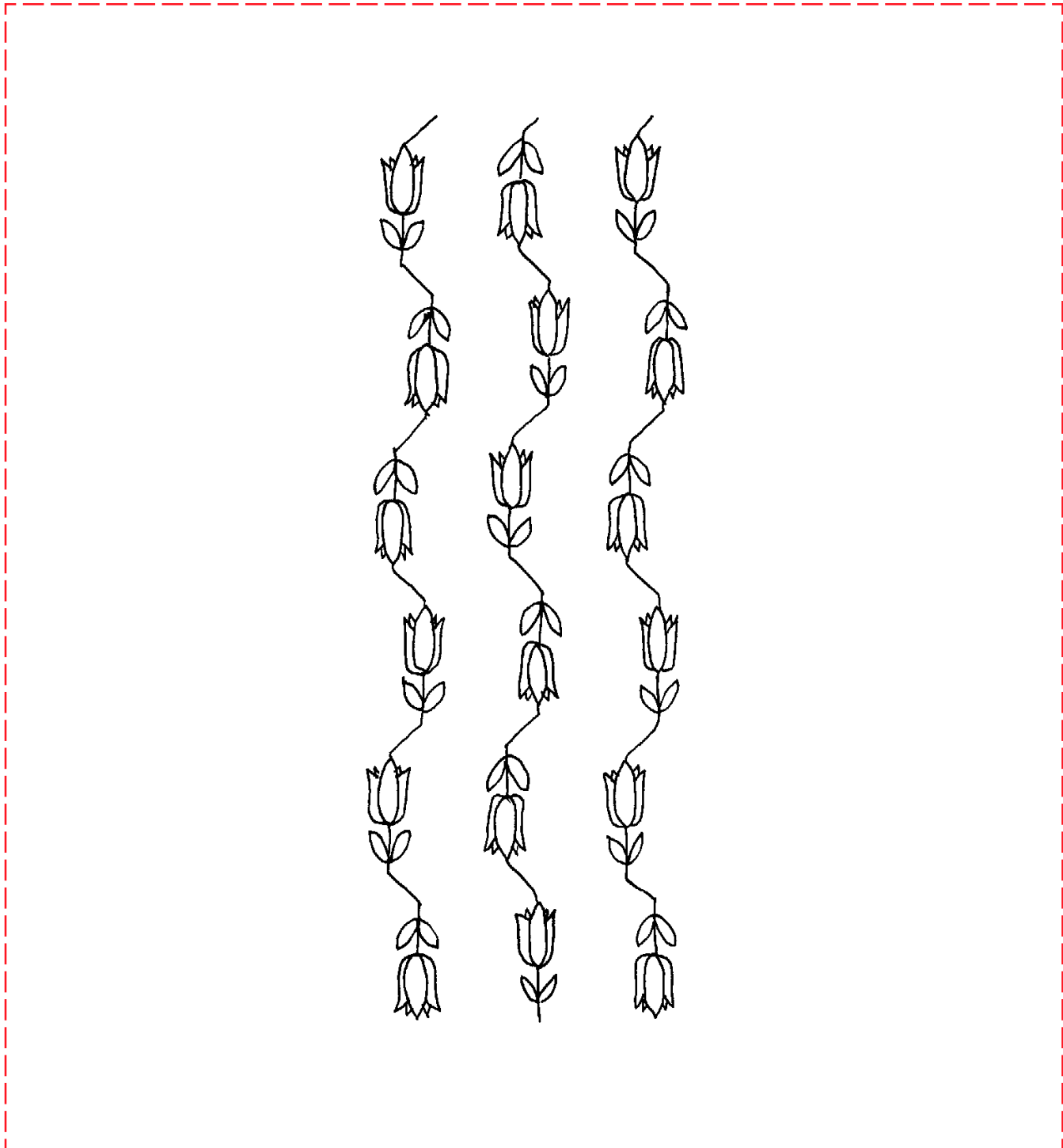



# Monogram

(*artista* 200 only)

|                       |                                |
|-----------------------|--------------------------------|
| Fabric .....          | firm fabric, 8" x 12"          |
| Stabilizer .....      | heavyweight cut-away, 8" x 12" |
| Needle .....          | 90/14 Embroidery               |
| Thread .....          | Isacord embroidery             |
| Presser Foot .....    | Sideways Motion Foot #40C      |
| Stitch .....          | monogram alphabet              |
| .....                 | directional straight stitch    |
| Needle Position ..... | center                         |

## Notes

*In this exercise, you will plot, program, and stitch a monogram, using the directional straight stitch to move from the end of one letter to the beginning of the next. Using the Long Stitch function omits every other stitch point in the 9mm long directional stitch, making it easy to remove connecting stitches. Using the Securing function ensures that letters are securely "tied" at the ends.*

Remove the transparent monogram templates from the pocket in the back of your owner's manual. Find the letters that are your initials.

Using the template, plot your initials on the fabric, marking the beginning and ending points of each letter. *Note: On the templates, an o indicates the beginning of a stitch pattern, and a + indicates the end of a stitch pattern. When plotting points, make sure that the template shows the toes of the "presser footprint" pointing forward, and "BERNINA" reads correctly. Starting and stopping points also appear in the Stitch Altering Area of the **artista** 200.*

Using the clear compass template, determine the direction and length (the number of "foot prints") between the end of the first letter and the beginning of the second. Be sure that direction 16 is at the top of the template. Repeat for the second and third initials.

Program your initials and the required number and direction of straight stitch #39 in Combi Mode. Engage the Long Stitch function for all #39 stitches, and insert the Securing function at the end of all three letters. Save.

Starting at the marked point at the beginning of the first initial, stitch the monogram sequence.

*Note: Some adjustments to stitch combination formulas may be necessary depending on the fabric, thread, and stabilizer used to create the stitch sample.*

**Preview: artista 200**  
 Select Preview > Sewing View.  
 A diagram appears screen showing how the monogram will look when it is stitched.

# Monogram Sample

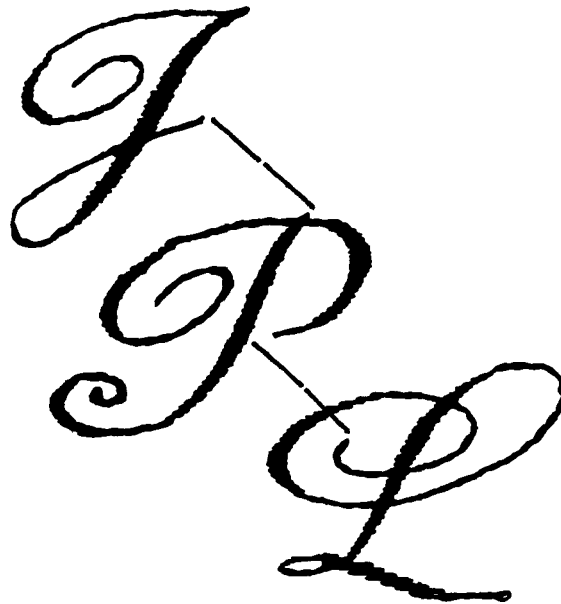



# Scalloped Edge

(*artista 200* only)

|                       |                                 |
|-----------------------|---------------------------------|
| Fabric .....          | chamois, 8" x 12"               |
| Stabilizer .....      | heavyweight tear-away, 8" x 12" |
| Needle .....          | 90/14 Embroidery                |
| Thread .....          | 30 weight cotton embroidery     |
| Presser Foot .....    | Sideways Motion Foot #40C       |
| Stitch .....          | directional straight stitch     |
|                       | multi-motion scallop            |
| Needle Position ..... | center                          |

## Notes

Affix the stabilizer to the back of the fabric with a light application of HRFive spray adhesive. Fold in half to 4" x 12".

Select Combi Mode. Program the following stitch combination:

- stitch #507, two times
- stitch #39, direction 2, 1x, between the two scallops
- stitch #39, direction 14, 1x, after the second scallop
- select the second scallop; engage Vertical Mirror Image
- select each of the directional straight stitches; engage the Long Stitch function; this will make the connecting stitches easier to clip and remove.

Save to an empty folder.

Stitch, guiding gently.

If necessary, fine tune the directional stitching so that the end of the scallops meet as shown in the illustration.

## Scalloped Edge Sample

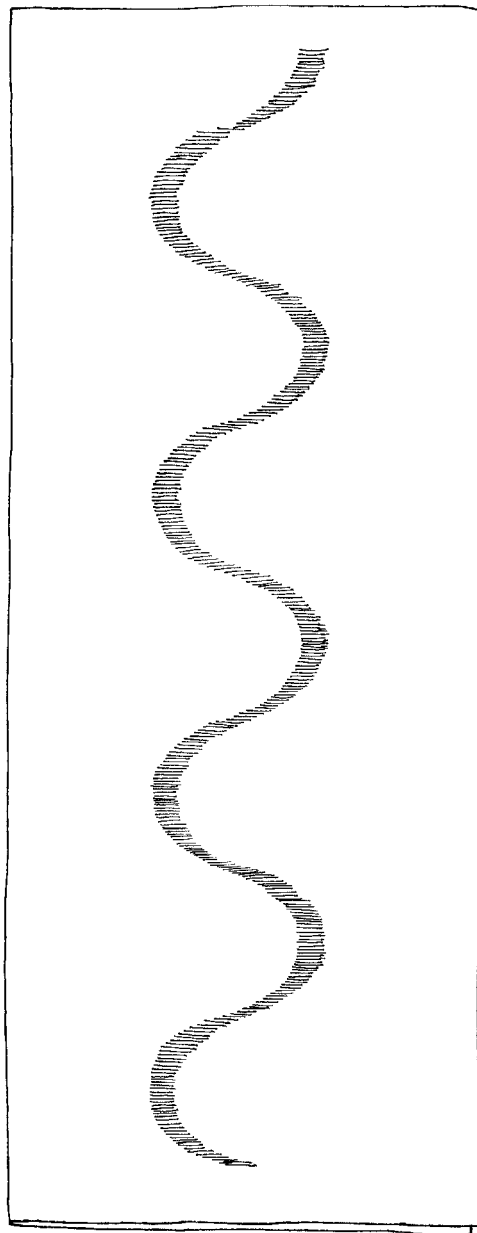





# Stacked Scallop Edge

(*artista 200 only*)

|                       |                                 |
|-----------------------|---------------------------------|
| Fabric .....          | chamois, 8" x 12"               |
| Stabilizer .....      | heavyweight tear-away, 8" x 12" |
| Needle .....          | 90/14 Embroidery                |
| Thread .....          | 30 weight cotton embroidery     |
| Presser Foot .....    | Sideways Motion Foot #40C       |
| Stitch .....          | as indicated                    |
| Needle Position ..... | center                          |

## Notes

Place stabilizer behind fabric, bonding with a light application of HRFive spray adhesive. Fold fabric/stabilizer in half to 4" x 12". Mark a large + shape on the fabric as a reference/guideline.

Program the following stitches in Combi Mode:

- stitch #507, 3x
- touch Pattern Begin; the cursor moves between the first and second scallops
- stitch #39, direction 2 - 3x **between** the first and second scallop
- stitch #39, direction 14 - 3x **between** second & third scallop
- engage Long Stitch function for the Directional stitches only

Save the stitch combination.

Stitch from one end of the fabric to the other, guiding fabric so that the + stays parallel and perpendicular to the presser foot.

Partially trim fabric from scallops. *Note: To create edging, trim fabric from outer edge, then apply YLI Pearl Crown Rayon to the edge using Embroidery Foot #6 or Clear Embroidery Foot #39 and a small zigzag stitch.*

*Note: Some adjustments to stitch combination formulas may be necessary depending on the fabric, thread, and stabilizer used to create the stitch sample.*

## Stacked Scallop Edge Sample

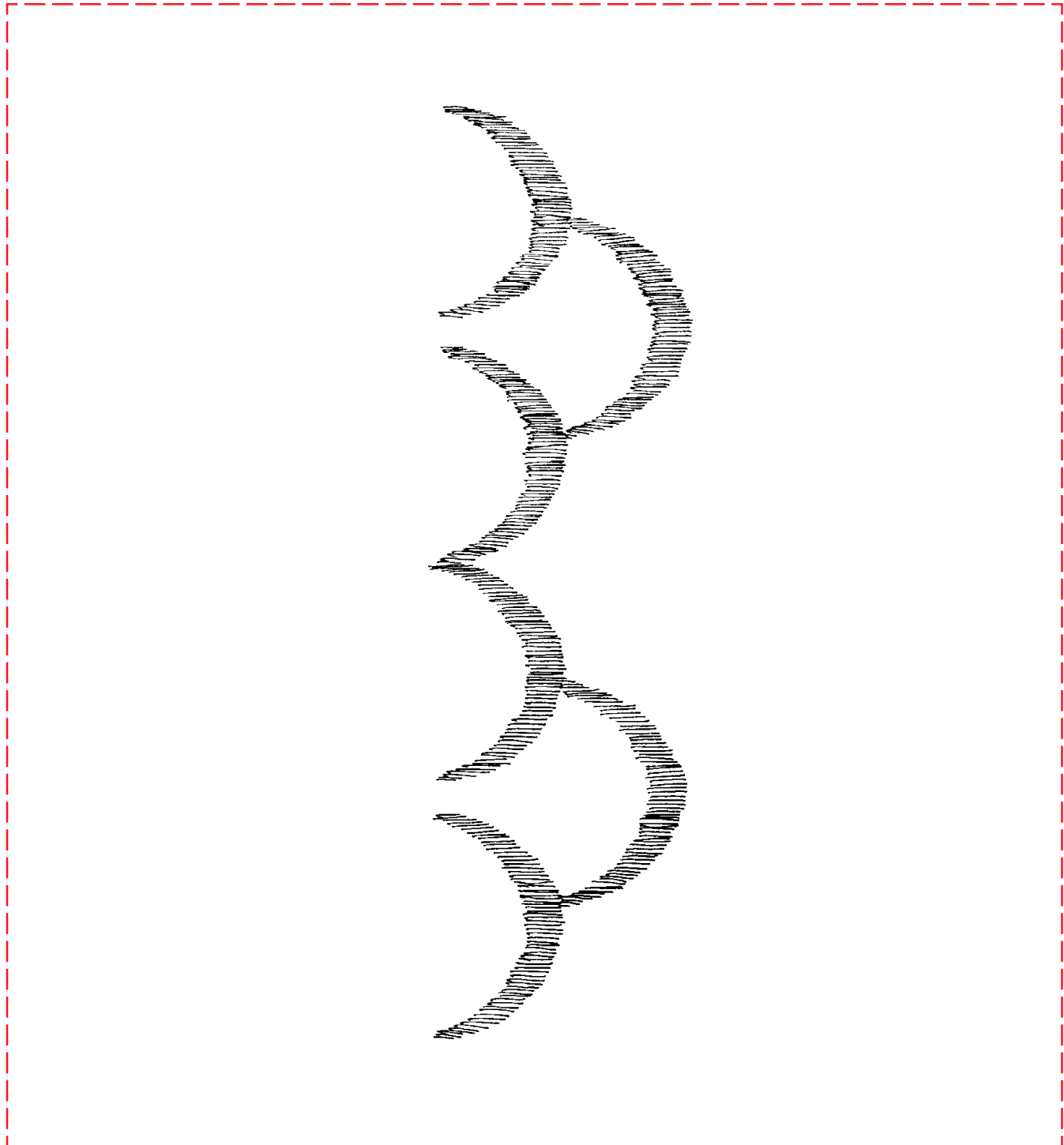



# Directional Quilting

(*artista 200 only*)

|                       |                                             |
|-----------------------|---------------------------------------------|
| Fabric .....          | two pieces cotton quilting fabric, 4" x 12" |
| Stabilizer .....      | cotton needle-punched batting, 4" x 12"     |
| Needle .....          | 90/14 Embroidery                            |
| Thread .....          | 30 weight cotton embroidery                 |
| Presser Foot .....    | sideways Motion Foot #40C                   |
| Stitch .....          | directional straight stitch                 |
| Needle Position ..... | center                                      |

## Notes

Affix the batting to the back of the fabric with a light application of HRFive spray adhesive. "Baste" the backing to the other side of the batting in the same manner to create a "quilt sandwich."

Select Combi Mode. Program the following stitch combination:

- stitch #39, direction 8, 1x,
- stitch #39, direction 4, 2x,
- stitch #39, direction 8, 3x,
- stitch #39, direction 12, 2x,
- stitch #39, direction 8, 2x,

Save to an empty folder.

Select Combi Mode. Program the following stitch combination:

- stitch #39, direction 8, 2x,
- stitch #39, direction 12, 1x,
- stitch #39, direction 8, 1x,
- stitch #39, direction 4, 1x

Save to an empty folder.

Draw a line from one end of the fabric to the other, marking the center of the fabric. Stitch each stitch combination one time, aligning the center of the presser foot with the drawn line at the beginning of each line of stitching, and keeping the foot parallel to the line as the fabric moves from side to side under the foot.

Trim and mount the sample.

# Directional Quilting Sample

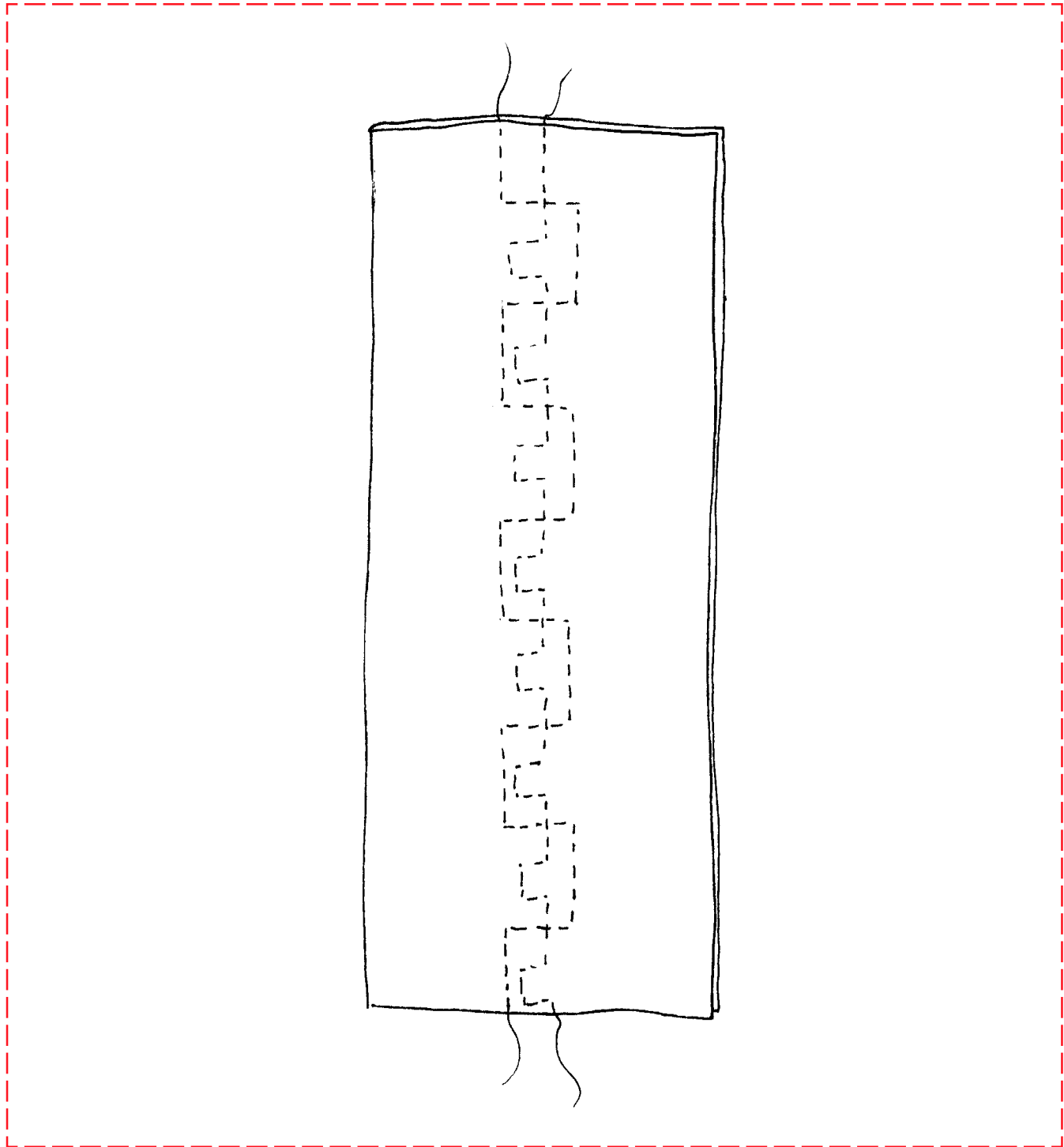

## Directional Baubles

(*artista* 200 only)

|                       |                                 |
|-----------------------|---------------------------------|
| Fabric .....          | firm, woven fabric, 8" x 12"    |
| Stabilizer .....      | heavyweight tear-away, 8" x 12" |
| Needle .....          | 90/14 Embroidery                |
| Thread .....          | 30 weight cotton embroidery     |
| Presser Foot .....    | Sideways Motion Foot #40C       |
| Stitch .....          | as indicated                    |
| Needle Position ..... | center                          |

## Notes

*This is a fun and different way to use the **artista** 200's directional capabilities. It makes use of the new Sub-Divider 2 feature, which acts as a stop within a combination. A Sub-Divider 2 also allows you to continue sewing other parts of a stored stitch combination.*



- Select Combi Mode. Program the following combination of stitches:
  - stitch #654, stitch length = 2mm
  - stitch #651
  - stitch #654, SL=2, Horizontal Mirror Image
  - Sub-Divider 2
  - stitch #39, direction 4- 3x
  - Subdivision
  - stitch #431
  - Sub-Divider 2
- Save to an empty folder.
- Place the stabilizer under the fabric.
- Begin sewing the motif. After the first three patterns have been stitched the **artista** 200 will automatically stop at the Sub-Divider 2.
- Release the foot control, then begin sewing again. The **artista** 200 automatically moves to the directional section of the combination, then stops at the next Sub-Divider 2.
- Release the foot control. Raise the presser foot and pivot the fabric 180°. Resume stitching; the next stitch pattern stitches over the previous directional stitching. Again, the **artista** stops automatically at the end of the stitch pattern.
- Pivot 90° and continue sewing the combination as shown.
- Repeat to create an interesting linear embellishment.
- Trim and mount sample.

# Directional Baubles Sample

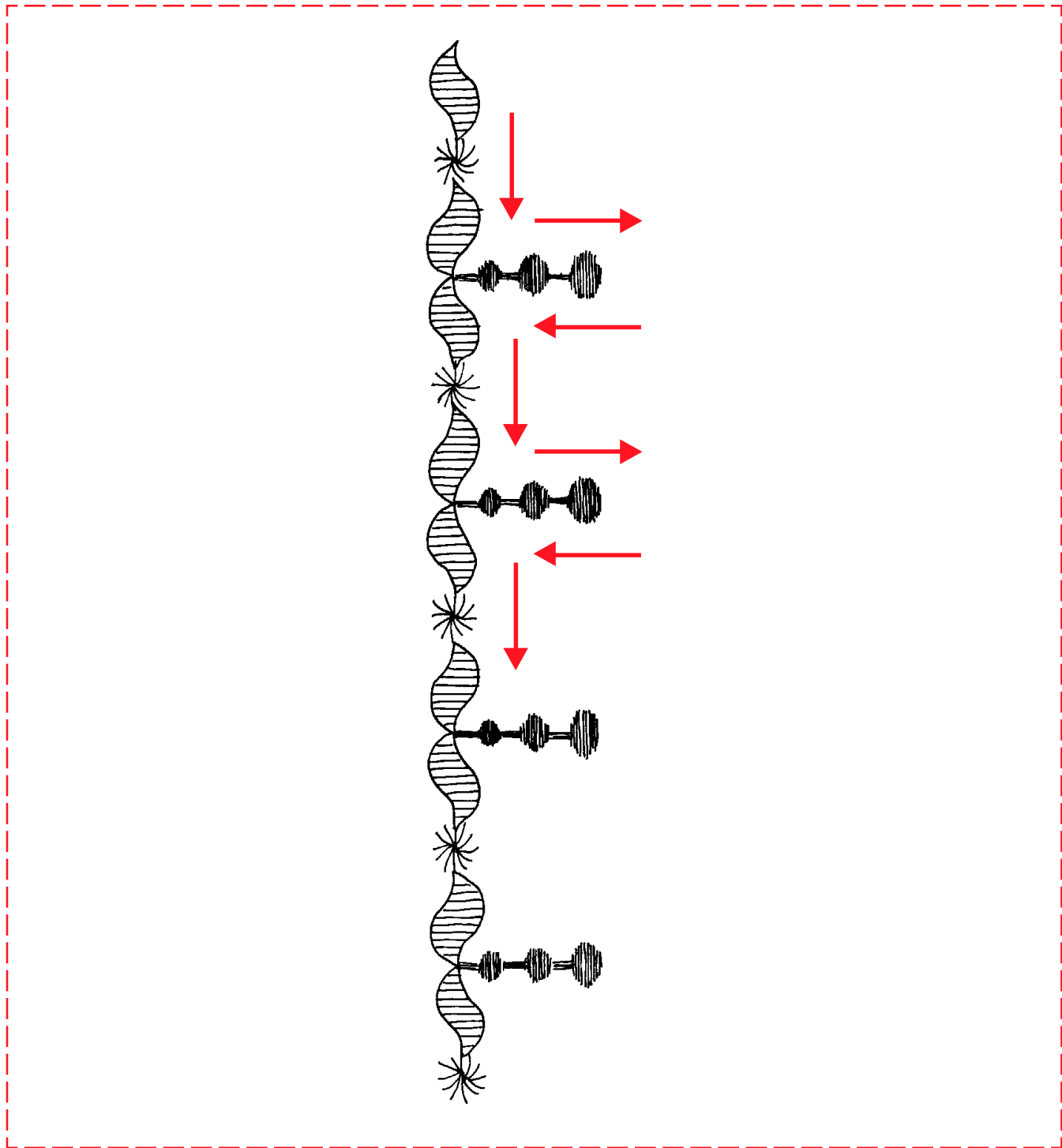

## **Class 7**

# **Product Reference List**

## **Directional Stitching**

*Feet-ures*, Volumes 1 and 2

Sideways Motion Foot #40C

Embroidery Foot #6

Clear Embroidery Foot #39

BERNINA® Iron

BERNINA® Ironing System

### Thread

Mettler 30 weight Cotton Embroidery

### Needles

Embroidery

Microtex Sharp

### Stabilizers

OESD Heavyweight Tear-Away

OESD Heavyweight Cut-Away

OESD Aqua Film

HRFive Spray Adhesive

Nifty Notions “Cut for the Cure” Rulers

Rotary Cutter and Mat

Temporary/Wash-Away Fabric Markers