

CIFLUX: III

CIFLUX: III



2HP|3HP CYCLONE
1 MICRON CANISTER

LAGUNA



Thank you for investing in a Laguna Tools CFLUX2 or CFLUX3 cyclone dust collector. This cyclone is one of a family of unique machines proudly offered by Laguna Tools. Every Laguna machine is engineered for years of dependable service. Please feel free to contact Laguna Tools if you have a question or suggestion. We appreciate working with you and your choice of a Laguna Tools machine for your shop.

Regards,
Torben Helshoj
President & Founder Laguna Tools

Dealer Machinery Warranty

New woodworking machines sold by Laguna Tools carry a two-year warranty effective from the date of dealer invoice to consumer. Machines sold through dealers must be registered with Laguna Tools within 30 days of purchase to be covered by this warranty. Laguna Tools guarantees all new machine sold to be free of manufacturers' defective workmanship, parts and materials. We will repair or replace, without charge, any parts determined by Laguna Tools, Inc. to be a manufacturer's defect. We require that the defective item/part be returned to Laguna Tools with the complaint. An RMA (return merchandise authorization) must be requested, from Laguna Tools, and included with any and all parts or machines returned to Laguna Tools for warranty consideration. Any machines returned to Laguna Tools must be returned with packaging in the same manner in which it was received. If a part or blade is being returned it must have adequate packaging to ensure no damage is received during shipping. In the event the item/part is determined to be damaged due to lack of maintenance, cleaning or misuse/abuse, the customer will be responsible for the cost to replace the item/part, plus all related shipping charges. This limited warranty does not apply to natural disasters, acts of terrorism, normal wear and tear, product failure due to lack of maintenance or cleaning, damage caused by accident, neglect, lack of or inadequate dust collection, misuse/abuse or damage caused where repair or alterations have been made or attempted by others.

This manual applies to the CFLUX2 and CFLUX3 cyclone dust collector. Enter the model number and serial number below for quick reference when ordering accessories, supplies or parts. NOTE: The model and serial number plate can be found on the Top Upright Support, on the right side near filter and ON/OFF switch.

Model: _____

Serial: _____

800-234-1976

www.lagunatools.com



CONTENTS

Warranty	02
Safety	04
Important Safety Instructions	05
General Safety Rules	09
Wiring Diagrams	12
Motor Specifications	13
Programming Remote Control	16
Unpacking	17
Assembly	18
Power Supply	29
Operation	30
Maintenance	30
Trouble Shooting	33
Parts Breakdown / Exploded Views	35
Parts List	40
Specifications	46 & 47
Supplies	46 & 47



SAFETY

READ AND UNDERSTAND THIS MANUAL AND ALL INSTRUCTIONS BEFORE USING THIS EQUIPMENT. Failure to follow all instructions may result in electric shock, fire and/or serious personal injury or property damage! Electronic copies of this manual are available at www.lagunatools.com.

SAFETY GUIDELINES - DEFINITIONS

This manual contains information that is important for you to know and understand. This information relates to protecting YOUR SAFETY and PREVENTING EQUIPMENT PROBLEMS. To help you recognize this information, we use the symbols below. Please read the manual and pay attention to these sections.



Indicates an imminently hazardous situation which, if not avoided, **will** result in death or serious injury.



Indicates a potentially hazardous situation which, if not avoided, **could** result in death or serious injury.



Indicates a potentially hazardous situation which, if not avoided, **may** result in minor or moderate injury.

CAUTION

(Used without the safety alert symbol) indicates a potentially hazardous situation which, if not avoided, **may** result in property damage.

LAGUNA

Woodworking (and similar materials) can be dangerous if safe and proper operating procedures are not followed. As with all machinery, there are certain hazards involved with the operation of the machine. Using the machine with respect and caution will considerably lessen the possibility of personal injury. However, if normal safety precautions are overlooked or ignored, personal injury to the operator may result. Safety equipment such as guards, push sticks, hold-downs, featherboards, goggles, dust masks and hearing protection can reduce the potential for injury. Even the best guard will not make up for poor judgement, carelessness or inattention. **Always use common sense** and exercise caution in the workshop. If a procedure feels dangerous, do not try it. Figure out an alternative procedure that is safer. **REMEMBER:** Your personal safety is your responsibility.

IMPORTANT SAFETY INSTRUCTIONS

WARNING

This machine was designed for certain applications only. We strongly recommend that this machine not be modified and/or used for any application other than that for which it was designed. If you have any questions relative to a particular application, DO NOT use the machine until you have first contacted the manufacturer to determine if it can or should be performed on the product.

If you have any questions relative to its application DO NOT use the product until you have contacted the manufacturer and we have advised you.

When using an electrical appliance/machine, basic precautions should always be followed, including the following:

READ ALL INSTRUCTIONS BEFORE USING (THIS APPLIANCE/MACHINE)

WARNING

To reduce the risk of fire, electric shock, or injury:

1. Do not leave appliance when plugged in. Unplug from outlet when not in use and before servicing.
2. Do not use outdoors or on wet surfaces
3. Do not allow to be used as a toy. Close attention is necessary when used by or near children.
4. Use only as described in this manual. Use only manufacturer's recommended attachments.
5. Do not use with damaged cord or plug. If appliance is not working as it should, has been dropped, damaged, left outdoors, or dropped into water, return it to a service center.



6. Do not pull or carry by cord, use cord as a handle, close a door on cord, or pull cord around sharp edges or corners. Do not run appliance over cord. Keep cord away from heated surfaces.
7. Do not unplug by pulling on cord. To unplug, grasp the plug, not the cord.
8. Do not handle plug or appliance with wet hands.
9. Do not put any object into openings. Do not use with any opening blocked; keep free of dust, lint, hair, and anything that may reduce air flow.
10. Keep hair, loose clothing, fingers, and all parts of body away from openings and moving parts.
11. Turn off all controls before unplugging.
12. Use extra care when cleaning on stairs.
13. Do not use to pick up flammable or combustible liquids, such as gasoline, or use in areas where they may be present.
14. Connect to a properly grounded outlet only. See Grounding Instructions.

SAVE THESE INSTRUCTIONS

1. Read and understand the warnings posted on the machine and in this manual. Failure to comply with all of these warnings may cause serious injury.
2. Replace the warning labels if they become obscured or removed.
3. These 2HP & 3HP Portable Cyclone Dust Collectors are designed and intended for use by properly trained and experienced personnel only. If you are not familiar with the proper and safe operation of this type of dust collector, do not use until proper training and knowledge have been obtained.
4. Do not use this machine for other than its intended use. If used for other purposes, **LAGUNA TOOLS INC.**, disclaims any real or implied warranty and holds itself harmless from any injury that may result from that use.
5. Always wear approved safety glasses/face shields while using this machine.
6. Before operating this dust collector, remove tie, rings, watches and other jewelry, and roll sleeves up past the elbows. Remove all loose clothing and confine long hair. Non-slip footwear or anti-skid floor strips are recommended. Do **not** wear gloves.
7. Wear ear protectors (plugs or muffs) during extended periods of operation.
8. Some dust created by power sanding, sawing, grinding, drilling and other construction activities contain chemicals known to cause cancer, birth defects or other reproductive harm. Some examples of these chemicals are: (next page)



- Lead from lead-based paint.
- Crystalline silica from bricks, cement, and other masonry products.
- Arsenic and chromium from chemically treated lumber.

Your risk of exposure varies, depending on how often you do this type of work. To reduce your exposure to these chemicals, work in a well-ventilated area and work with approved safety equipment, such as face or dust masks that are specifically designed to filter out microscopic particles.

9. Do not operate this machine while tired or under the influence of drugs, alcohol or any medication.
10. Make certain the switch is in the **OFF** position before connecting the machine to the power source.
11. Make certain the machine is properly grounded.
12. Make all machine adjustments or maintenance with the machine unplugged from the power source.
13. Form a habit of checking to see that all extra equipment such as adjusting keys, wrenches, scrap, stock, and cleaning rags are removed away from the machine before turning on.
14. Keep safety guards in place at all times when the machine is in use. If removed for maintenance purposes, use extreme caution and replace the guards immediately when maintenance is complete.
15. Make sure the dust collector is on a flat even surface and the wheels locked in place before use.
16. Check damaged parts. Before further use of the machine, a guard or other part that is damaged should be carefully checked to determine that it will operate properly and perform its intended function. Check for alignment of moving parts, binding of moving parts, breakage of parts, mounting and any other conditions that may affect its operation. A guard or other part that is damaged should be properly repaired or replaced.
17. Provide for adequate space surrounding work area and non-glare, overhead lighting.
18. Keep the floor around the machine clean and free of scrap material, oil and grease.



19. Keep visitors a safe distance from the work area. **Keep children away.**
20. Make your workshop child proof with padlocks, master switches or by removing starter keys.
21. Give your work undivided attention. Looking around, carrying on a conversation and “horse-play” are careless acts that can result in serious injury.
22. Maintain a balanced stance at all times so that you do not fall or lean against the dust collector. Do not overreach or use excessive force to perform any machine operation.
23. Use the right tool at the correct speed and feed rate. Do not force a tool or attachment to do a job for which it was not designed. The right tool will do the job better and safer.
24. Use recommended accessories; improper accessories may be hazardous.
25. Maintain machinery with care. Follow instructions for lubricating and changing accessories.
26. Turn off the machine before cleaning. Use a brush or compressed air to remove dust or debris — do not use your hands.
27. Do not stand on the machine. Serious injury could occur if the machine tips over.
28. Never leave the machine running unattended. Turn the power off and do not leave the machine until it comes to a complete stop.
29. Never operate or run the machine without closing the drum up against the lid. Failure to do so will result in the machine amperage increasing and may trip your circuit.

Familiarize yourself with the following safety notices used in this manual:

SAFETY GUIDELINES - DEFINITIONS

This manual contains information that is important for you to know and understand. This information relates to protecting YOUR SAFETY and PREVENTING EQUIPMENT PROBLEMS. To help you recognize this information, we use the symbols, described earlier. Please read the manual and pay attention to these sections.



GENERAL SAFETY RULES



FAILURE TO FOLLOW THESE RULES MAY RESULT IN SERIOUS INJURY.

FOR YOUR OWN SAFETY, READ AND UNDERSTAND THE INSTRUCTION MANUAL BEFORE OPERATING THE MACHINE. Learn the unit's application and limitations as well as the specific hazards peculiar to it.

KEEP WORK AREA CLEAN. Cluttered areas and benches invite accidents.

DON'T USE IN DANGEROUS ENVIRONMENT. Don't use this unit in damp or wet locations, or expose it to rain. Keep work area well-lighted.

KEEP CHILDREN AND VISITORS AWAY. All children and visitors should be kept a safe distance from work area.

DISCONNECT UNIT before servicing.

CHECK DAMAGED PARTS. Before further use of the unit, properly repair or replace any part that is damaged.



FAILURE TO FOLLOW THESE RULES MAY RESULT IN SERIOUS INJURY.

ADDITIONAL SAFETY FOR DUST COLLECTORS

Intended use. This dust collector is only intended for collecting wo dust and chips from woodworking machines. Do not use this dust collector to collect metal, dirt, pebbles, drywall, asbestos, lead paint, silica, liquids, aerosols, or any flammable, combustible, or hazardous materials.

Hazardous dust. Dust created while using machinery may cause cancer, birth defects, or long-term respiratory damage. Be aware of dust hazards associated with each work piece material, and always wear a NIOSH-approved respirator to reduce your risk.

Dust allergies. Dust from certain woods may cause an allergic reaction in people and animals. Make sure you know what type of wo dust you will be exposed to in case there is a possibility of an allergic reaction.

LAGUNA

Wear respirator. Fine dust that is too small to be caught in the filter will be blown into the ambient air during operation. Always wear a NIOSH-approved respirator during operation and for a short time after to reduce your risk of permanent respiratory damage.

Emptying dust. When emptying dust from the collection container, wear a respirator and safety glasses. Empty dust away from ignition sources and into an approved container.

Disconnecting power supply. Turn the switch off, disconnect the dust collector from the power supply, and allow the impeller to come to a complete stop before leaving the machine unattended or doing any service, cleaning, maintenance, or adjustments.

Suspended dust particles and ignition sources. Do not operate the dust collector in areas where explosion risks are high. Areas of high risk include, but are not limited to, areas near pilot lights, open flames, or other ignition sources.

Fire suppression. Only operate the dust collector in locations that contain a fire suppression system or have a fire extinguisher nearby.

Impeller hazards. Do not place your hands or tools near the open inlet during operation for any reason. The powerful suction could easily cause accidental contact with the impeller, which will cause serious personal injury or damage to the machine. Always keep small animals and children away from open dust collection inlets.

Avoiding sparks. Do not allow steel or rocks to strike the impeller—this may produce sparks. Sparks can smolder in wo dust for a long time before a fire is detected. If you accidentally cut into wood containing metal (nails, staples, spikes, etc.), immediately turn **off** the dust collector, disconnect it from power, and wait for the impeller to stop—then empty the collection container into an approved airtight metal container.

Operating location. To reduce respiratory exposure to fine dust, locate permanently installed dust collectors away from the working area, or in another room that is equipped with a smoke detector. Do not operate the dust collector in rainy or wet locations—exposure to water may create a shock hazard or decrease the life of the machine.

Static electricity. Plastic dust lines generate high amounts of static electricity as dust chips pass through them. Although rare, sparks caused by static electricity can cause explosions or fire. To reduce this risk, make sure all dust lines are thoroughly grounded by using a grounding wire.



Regular cleaning. Regularly check/empty the collection bags or drum to avoid the buildup of fine dust that can increase the risk of fire. Make sure to regularly clean the surrounding area where the machine is operated—excessive dust buildup on overhead lights, heaters, electrical panels, or other heat sources will increase the risk of fire.

**SAVE THESE INSTRUCTIONS.
Refer to them often and use them to instruct others.**

WIRING DIAGRAMS

POWER CONNECTIONS

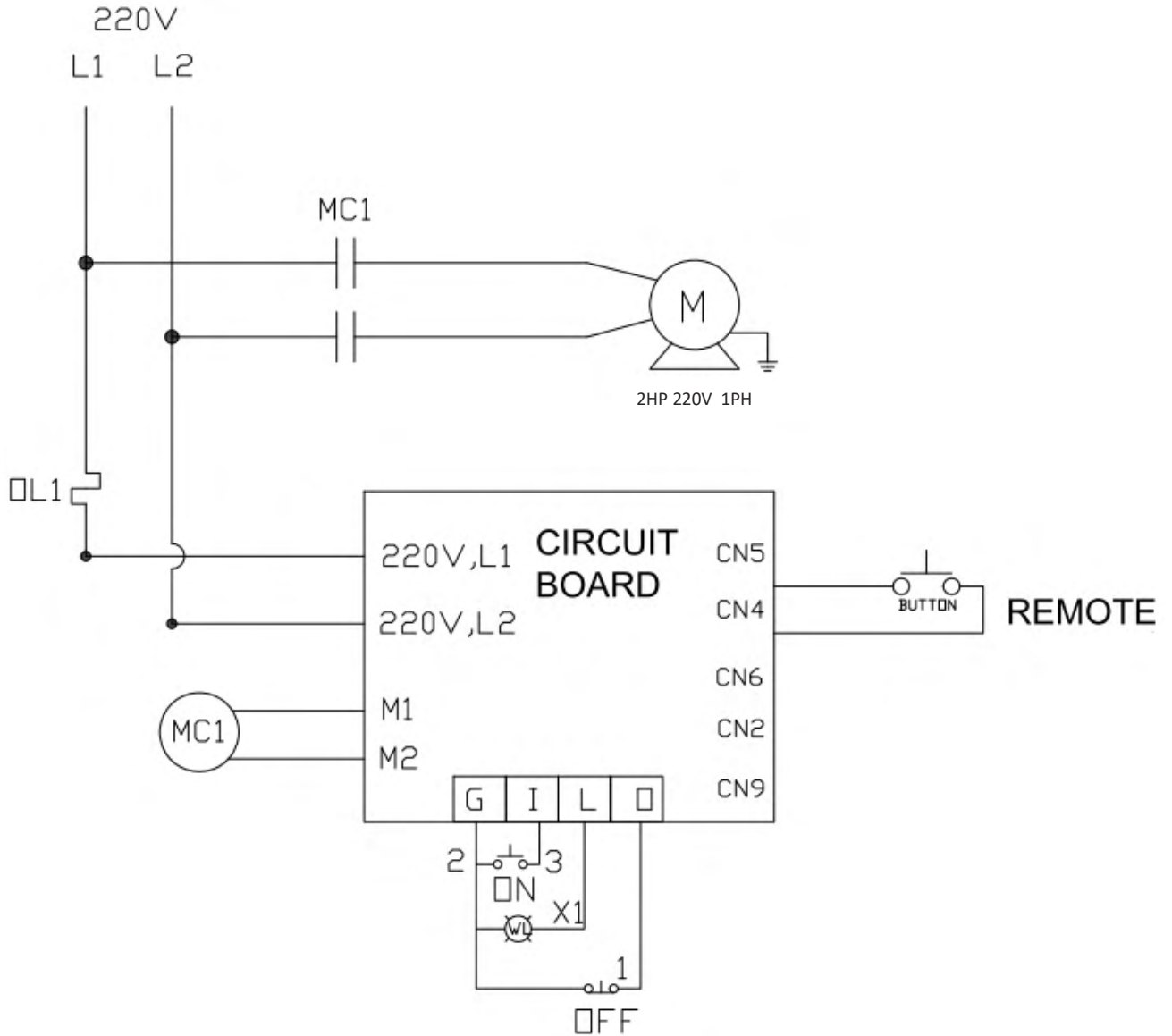

Figure 1: Power Connections & Wiring

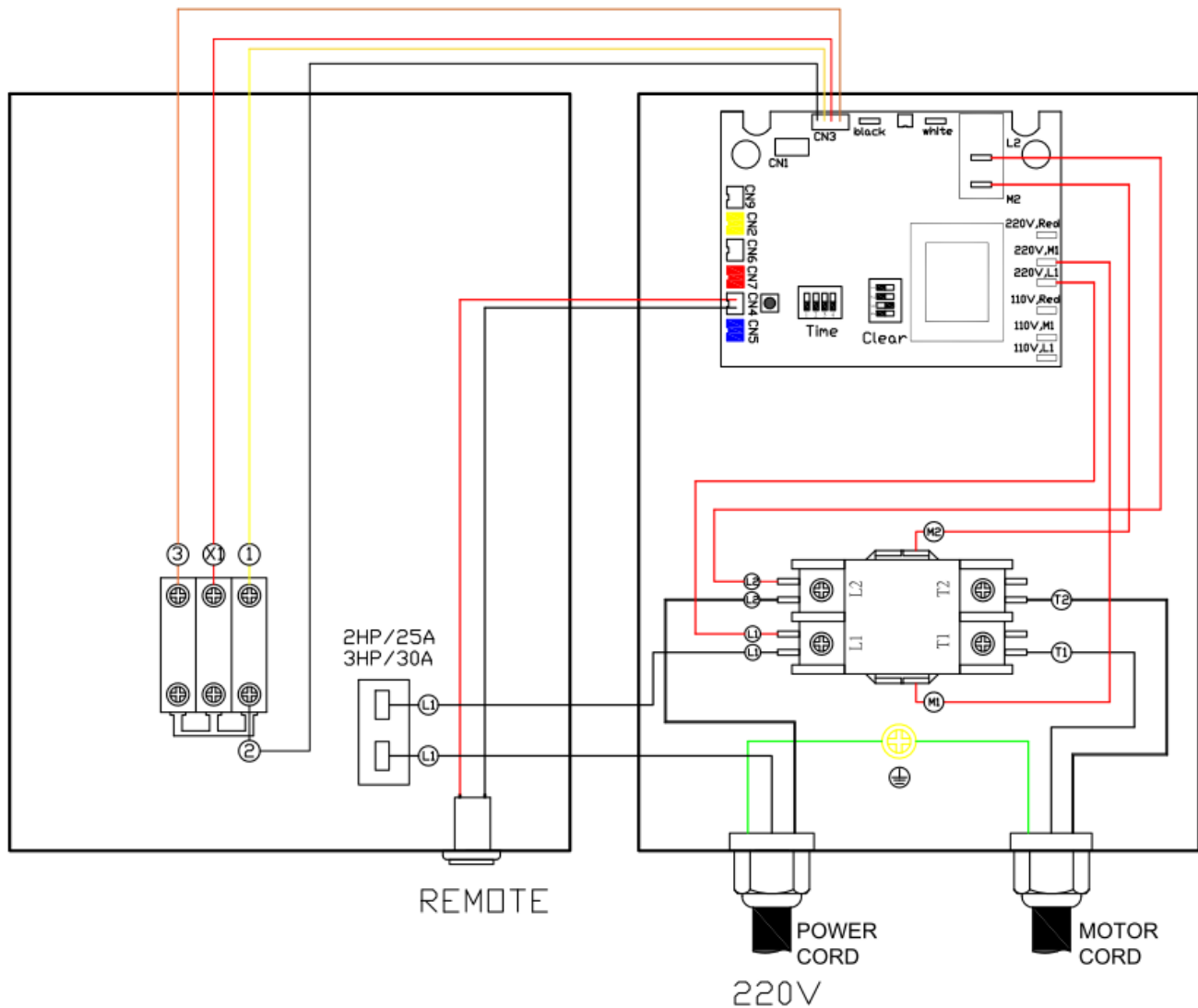

Figure 2: Internal Wiring



DO NOT EXPOSE THE MACHINE TO RAIN OR OPERATE THE MACHINE IN DAMP LOCATIONS.

MOTOR SPECIFICATIONS

Your machine is wired for 220 volts, 60 HZ alternating current. Before connecting the machine to the power source, make sure the switch is in the "OFF" position. An (appx.) 8' cord is included, a "plug" is NOT included. A plug must be installed by a qualified technician.



GROUNDING INSTRUCTIONS



THIS MACHINE MUST BE GROUNDED WHILE IN USE TO PROTECT THE OPERATOR FROM ELECTRIC SHOCK.

1. This appliance must be connected to a grounded metal, permanent wiring system; or an equipment-grounding conductor must be run with the circuit conductors and connected to the equipment-grounding terminal or lead on the appliance.

The installer, such as a qualified electrician, should connect and insulate the grounding conductor from a field wiring supply cable.

In the event of certain types of malfunctions or breakdowns, grounding provides a path of least resistance for electric current—in order to reduce the risk of electric shock.

Improper connection of the equipment-grounding wire can result in a risk of electric shock. The wire with green insulation (with or without yellow stripes) is the equipment-grounding wire. If repair or replacement of the power cord or plug is necessary, do not connect the equipment-grounding wire to a live (current carrying) terminal. Check with a qualified electrician or service personnel if you do not understand these grounding requirements, or if you are in doubt about whether the tool is properly grounded. If you ever notice that a cord or plug is damaged or worn, disconnect it from power, and immediately replace it with a new one.

Full Load amperage Draw

CFLUX2 Amp draw at 220V 14 Amps
CFLUX3 Amp draw at 220V 20 Amps

Power Supply Circuit Requirements

The power source circuit for your machine must be grounded and rated for the amperage given below. Never replace a circuit breaker on an existing circuit with one of higher amperage without consulting a qualified electrician to ensure compliance with wiring codes. **If you are unsure about the wiring codes in your area or plan to connect your machine to a shared circuit, consult a qualified electrician.**

CFLUX2 Circuit Size (220V).....20 AMP minimum
CFLUX3 Circuit Size (220V).....30 AMP minimum

LAGUNA

⚠ DANGER

IN ALL CASES, MAKE CERTAIN THE RECEPTACLE IN QUESTION IS PROPERLY GROUNDED. IF YOU ARE NOT SURE, HAVE A QUALIFIED ELECTRICIAN CHECK THE RECEPTACLE.

220 VOLT Single-Phase Operation

Your machine is wired for 220 volts, 60 HZ alternating current. Before connecting the machine to the power source, make sure the switch is in the "OFF" position. An (appx.) 8' cord is included, a "plug" is NOT included. A plug must be installed by a qualified technician.

FUNCTIONS of Switch & Remote Control



Figure 3: High Frequency Remote Control Receiver and Manual Switch

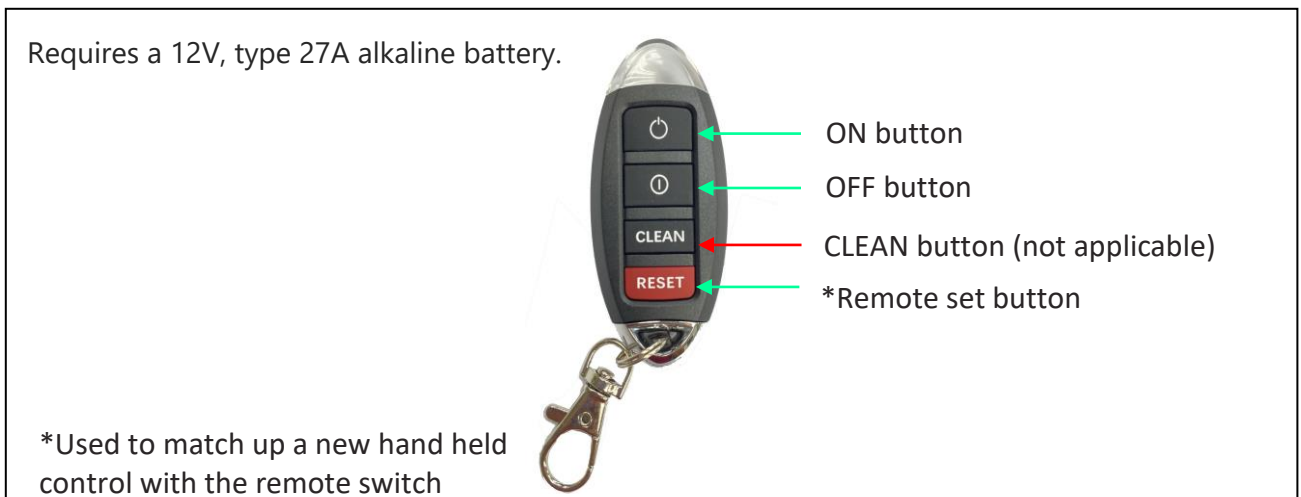

Figure 4: Hand Held Remote Control

PROGRAMMING THE REMOTE CONTROL

1. Ensure the machine is switch ON before programming the remote control.
2. Press the black set button on the bottom of the remote switch until you hear two beeps.
3. Press the Remote set button on your hand-held controller simultaneously with the black button until you hear three beeps to complete the set up.

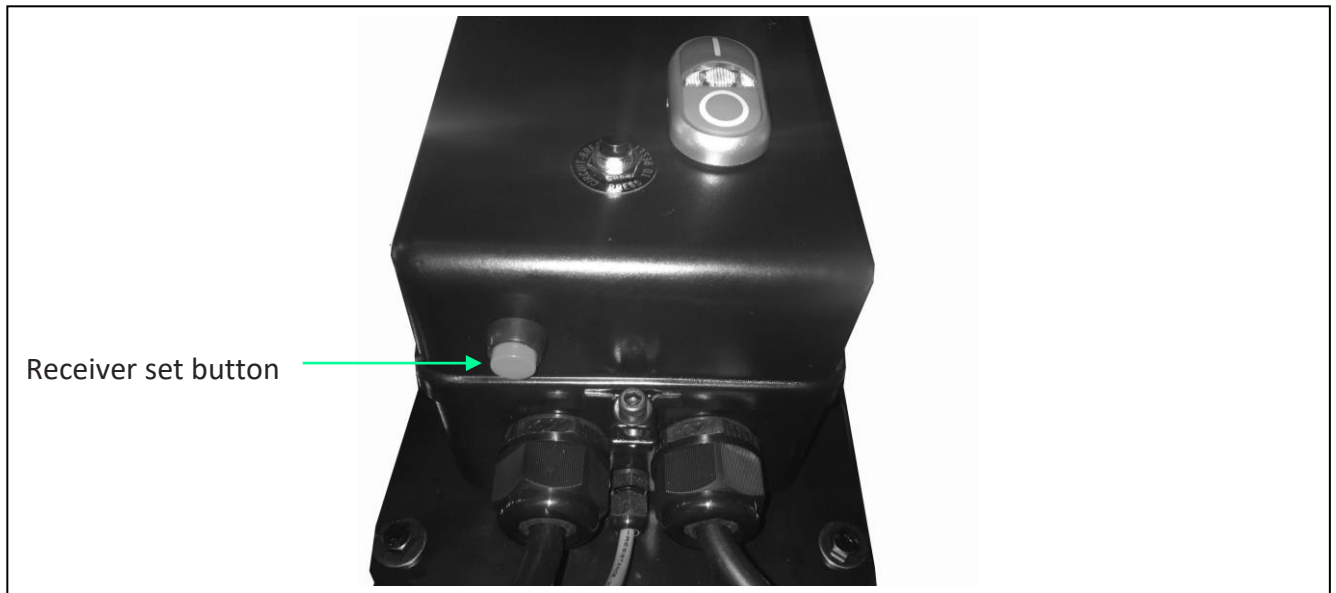

Figure 5: Receiver Set Button

LAGUNA

UNPACKING

Your 2HP or 3HP Mobile Dust Cyclone comes packed in a single box. Before attempting to assemble this machine, follow these directions for unpacking:

1. Carefully cut the banding straps and remove them from the box.
2. Cut along the tape line at the top of the box.
3. Remove all parts from the top of the foam and set aside.
4. Remove the foam packing material from the top of the machine and **set aside for further use, during assembly.**
5. Cut the cardboard box (top to bottom) in the four corners for easy removal of the box.
6. Carefully take out the machine components from the box and set aside.
7. Using the diagram below, ensure that all parts are present and in good condition.



DESCRIPTION (QUANTITY); Figure 6:

- | | |
|---------------------------------|--|
| A. Motor | P. Octagon drum foot pedal |
| B. Switch and remote controller | Q. Inlet adapter 8" by 4" x 2ports (CFLUX2 only) |
| C. Dust chute | Q. Inlet adapter 8" by 4" x 3ports (CFLUX3 only) |
| D. Top upright supports (3) | Q1. Inlet adapter 8" by 6" (CFLUX2 only) |
| E. Canister 1 Micron | R. Lower upright supports (3) |
| F. Base frame | S. Drum insert |
| G. Rotation shaft | T. Upright support reinforcement plate (3) |
| H. Rotation paddle (2) | U. Foot pedal bar (left and right) |
| I. Crossbar | V. Foot pedal assembly fittings |
| J. Octagon drum lid | V1. Lower triangular support plate (2) |
| K. Cyclone funnel | V2. Foot pedal bar support (2) |
| L. Cyclone barrel | V3. Lower support plate (2) |
| M. Intake cylinder | W. Hardware box |
| N. Canister cover plate | X. Operating and Parts Manual |
| O. Octagon front and back panel | Y. Dust bags |



Report any missing or damaged parts to your dealer or distributor. Prior to tool assembly and use, read this manual thoroughly to familiarize yourself with proper assembly, maintenance, and safety procedures.

ASSEMBLY



This step requires two adults. The 2 HP & 3 HP Mobile Dust Cyclones are heavy, be careful when lifting and handling! Failure to comply may cause serious injury and/or damage to the machine and/or property!

Tools/items Required:

10mm wrench / 12mm wrench / 14mm wrench
Phillips screwdriver
4mm hex wrench / 5mm hex wrench
Plug for cord, 3 wire



To assemble your dust cyclone, follow these steps:

For your own safety, do not connect the machine to the power source until the machine is completely assembled. Please also make sure that you read and understand the entire instruction manual.

ASSEMBLY TIME ESTIMATE *5 to 6 hours*

Visit the Laguna Tools Video page for setup assistance.

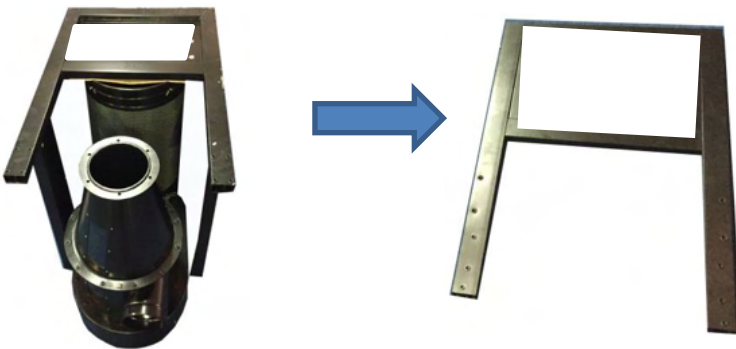
LAGUNA

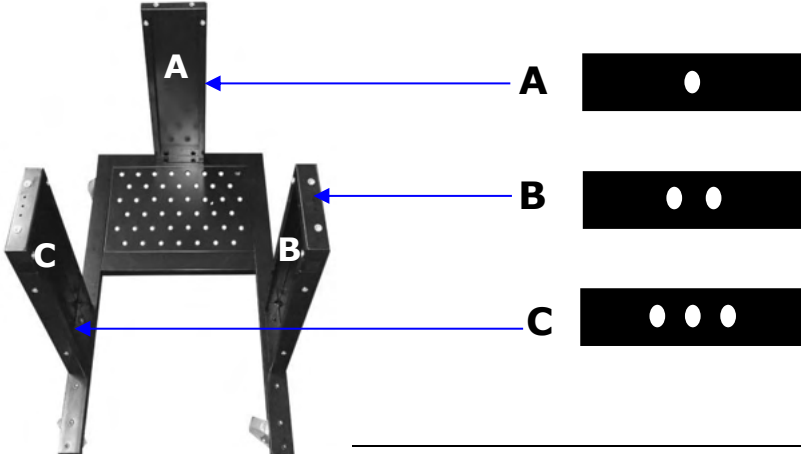
	<p>1. Place the empty, top, foam packing insert which contained the individual parts) upside-down on the floor. Place the main unit into the Styrofoam insert upside-down. Make sure the unit is centered properly and resting solidly in the Styrofoam insert for the next steps.</p>
	<p>2. Remove the base which has been bolted to the (3) top upright supports. Keep the bolts for completing step 4.</p>
	<p>3. Turn base upside-down. Use (16) 5/16" x 3/4" hex bolts and (16) 5/16" flat washers. Attach the (2) 4" casters with brakes to the base. The casters wit brakes should be attached to the side with the opening. The remaining (2) 4" swivel casters must attach to the other end on the base.</p>
	<p>4. Turn the base over with it standing on the (4) 4" casters and secure the three lower upright support panels using (6) 3/8" x 3/4" hex bolts and (6) 3/8" x 7/8" flat washers. A – shown with one dot is located on the canister side. B – shown with two dots is located on the front side C – shown with three dots is located on the opposite end.</p>

LAGUNA

	<p>5. (Intake cylinder, cyclone barrel and cyclone funnel). Install 3 x 6mm foam tape to rims on each location shown on the left.</p> <ul style="list-style-type: none"> - Top rim of the intake cylinder - Top rim of the cyclone barrel - Top and lower rim of cyclone funnel
	<p>6. Attach the intake cylinder to the dust chute using (4) 5/16"x5/8" hex spring bolts. Then, attach the cyclone barrel onto the dust chute using (12) 5/16"x3/4" hex bolts and (12) 5/16"x18x2t flat washers followed by attaching the cyclone funnel to the barrel using (12) 5/16"x3/4" hex bolts, (24) 5/16"x18x2 flat washers and (12) 5/16" hex nuts.</p>
	<p>7. Secure the base with (3) lower upright support panels to the unit using (6) 5/16" x 3/4" hex bolts and (6) 5/16" x 1" flat washers.</p>
	<p>8. Secure the (3) upright support reinforcement plates using (12) 5/16" x 3/4" hex bolts and (12) 5/16" x 1" flat washers.</p>

LAGUNA

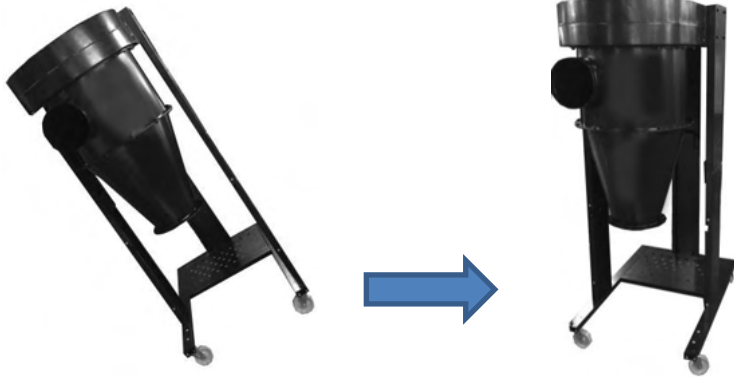

9. With the help of another person, lift the unit up carefully and rotate to the right-side-up with the motor on top and the wheels at the bottom.

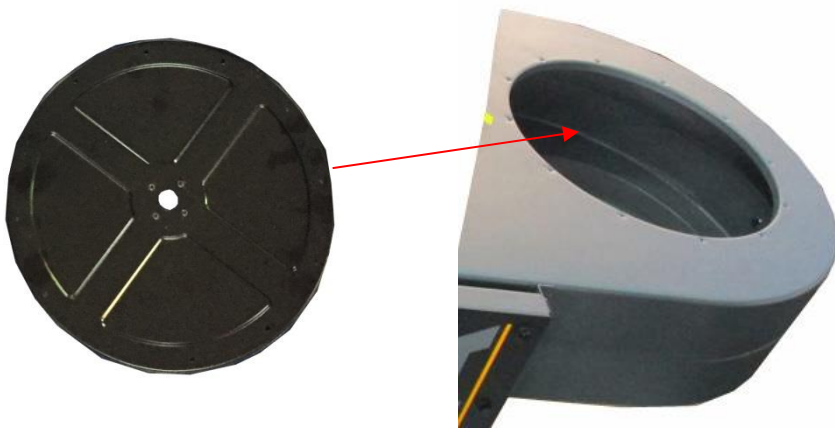

10. Attach the canister cover plate to the dust chute using (12) 3/16 x 1/2" sheet metal thread bolts.

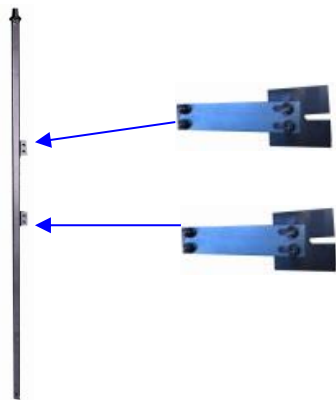

11. Take the (2) filter cleaning arms and assemble to the filter rotation shaft using (4) 1/4" x 5/8" hex bolts, (8) 1/4" flat washers, and (4) 1/4" hex nuts

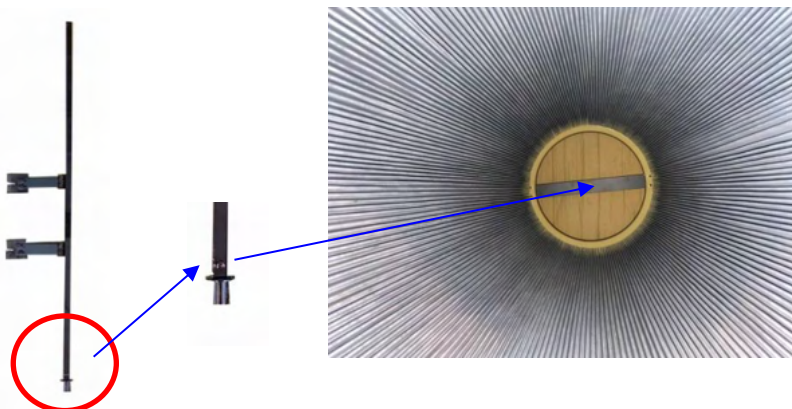

12. Insert the filter rotation shaft assembly into the HEPA filter from the top opening. It will be easier to insert while holding it at a slanted angle. The rotation shaft has a top and bottom end. The top end has bolt holes for the next step.

LAGUNA

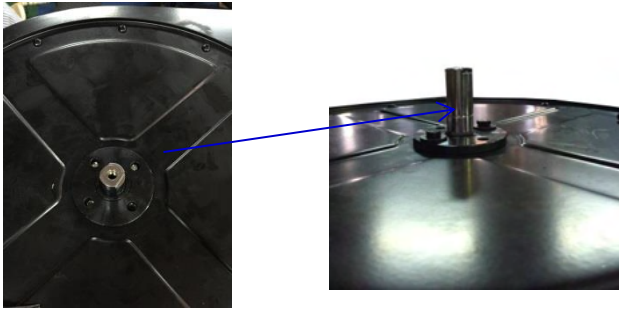

13. With the help of another person holding the filter, push the rotation shaft through the hole in the middle of the canister cover plate. Make sure to hold the rotation shaft above the canister cover plate.



14. While your assistant is holding the rotation shaft above the canister cover plate, assemble the canister filter to the dust chute. Tighten the band clamp and adjust the tightness accordingly to ensure the canister filter is tightly fitted onto the dust chute.

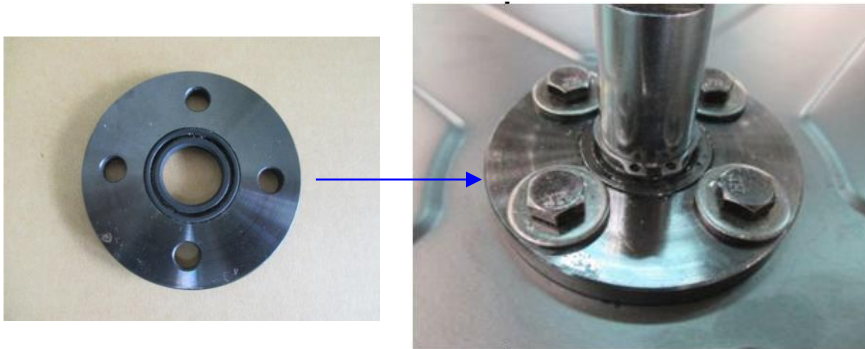

15. While holding the rotation shaft above the hole, insert the bearing onto the rotation shaft and pushing it down to the canister cover plate. This will affix the rotation shaft in place and you will not need to keep holding it up. Secure the bearing using (4) 1/4" x 3/4" hex bolts and (4) 1/4" x 19x 2 flat washers.

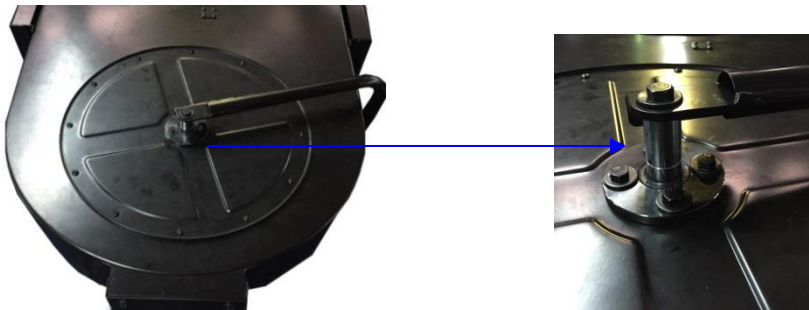

16. Attach and secure the rotation crank to the top of the rotation shaft using (1) 5/16" x 3/4" hex bolt and (1) 5/16" x 30x 3 flat washer.



17. Secure and tighten the (1) 5/16" x 3/4" and (1) 5/16" x 23 x 2 flat washer on the rotation shaft base.

LAGUNA

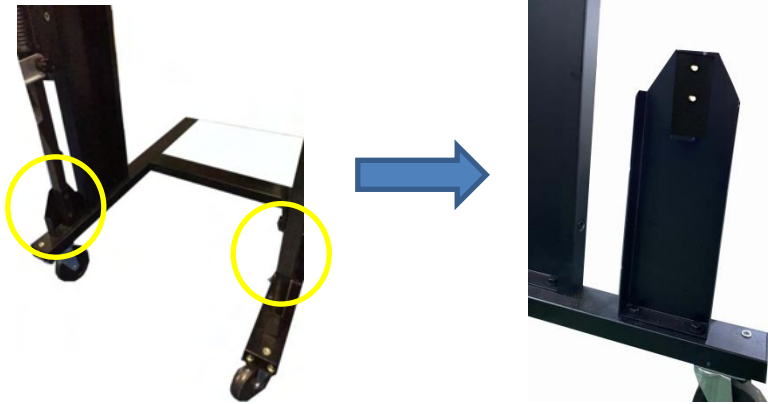

18. Secure the lower triangular support plate to the base using (2) 5/16" x 3/4" hex bolts and (2) 5/16" x 18 x 2 flat washers. Follow the same steps for the opposite side.



19. Secure the foot pedal support bracket to the lower upright support panel using (2) 5/16" x 1/2" carriage bolts, (2) 5/16" x 18 x 2 flat washers and (2) 5/16" hex nuts. Make sure the armrest of the support bracket is facing up. Follow the same steps for the opposite side.



20. Locate the two foot pedal bars provided. There is a left side and right side. To identify the correct side, look for the protruding nut, circled in red below. It should be facing upwards when you place the bars on the floor.



21. Ensure that the foot pedal bar is the correct side and slide the Foot pedal bar into the opening on the lower upright support panel. Take the lower support bracket and use (2) 5/16" x 1-3/4" hex bolts, (4) 5/16" flat washers and (2) 5/16" hex nuts to secure the lower end of the foot pedal bar to the inner side of the triangular support plate. Follow the same steps for the opposite side.

LAGUNA

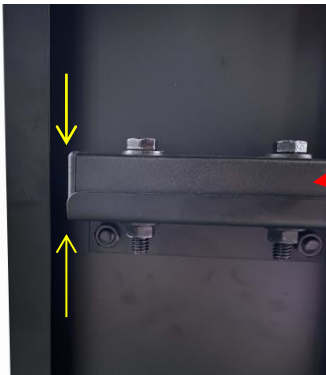

22. Secure the top end of the foot pedal bar to support bracket using (4) 5/16" x 1-3/4" hex bolts, (8) 5/16" x 18 x 2 flat washers and (4) 5/16" hex nuts. Make sure the foot pedal bar is pushed all the way to the end of the support bracket (indicated by yellow arrows). Follow the same steps for the opposite side.



U Channel

23. Secure the base of the foot pedal bar to the triangular support plate by holding the lower support plate vertically up against the foot pedal bar and secure the U channel onto the foot pedal bar using (2) 5/16" x 1-3/4" hex bolts, (4) 5/16" x 18 x 2 flat washers and (2) 5/16" hex nuts from the inside out. Follow the same steps for the opposite side.





24. Attach the two ends of the Octagon foot pedal to the nut on the foot pedal bar.



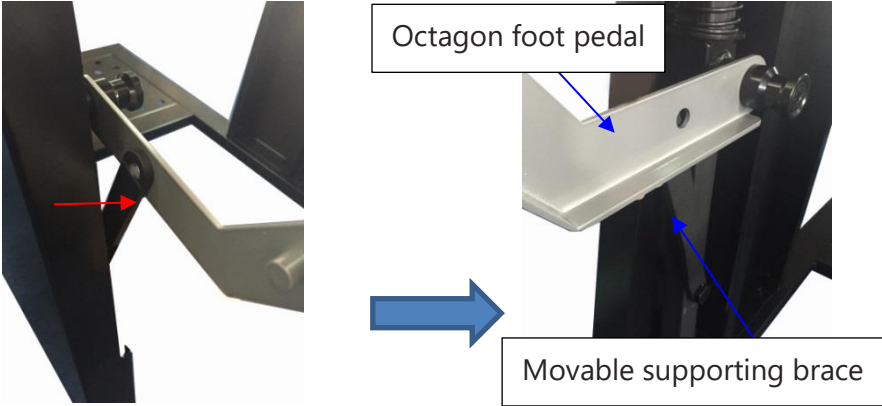
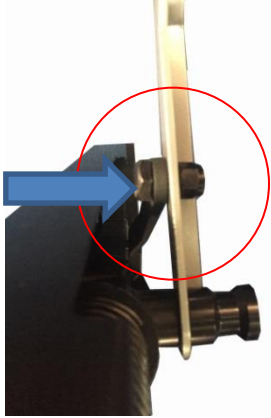

25. Secure the topping to the nut on the foot pedal bar using (1) M8 x 30mm hex bolt. Follow this step on the opposite side.

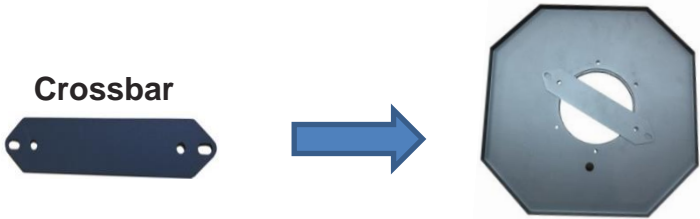
LAGUNA

 <p>Octagon foot pedal</p> <p>Movable supporting brace</p>	<p>26. Secure the movable supporting brace on the foot pedal bar with the octagon foot pedal using (2) 3/8" x 21mm hex bolts. Make sure the bolt head is on the inside of the octagon foot pedal. Adjust the tightness of this bolt accordingly. If this bolt is too tight, the Octagon foot pedal will not work smoothly. When too loose it will not pick up the Octagon drum.</p>
	<p>27. Secure the movable supporting brace on the foot pedal bar with the octagon foot pedal using (2) 3/8" x 21mm hex bolts. Make sure the bolt head is on the inside of the octagon foot pedal. Adjust the tightness of this bolt accordingly. If this bolt is too tight, the Octagon foot pedal will not work smoothly. When too loose it will not pick up the Octagon drum.</p>
 <p>You will find a tag on the cone with the following warning. Take note and remove tag when you have completed this step.</p> <div data-bbox="565 1247 919 1602" style="border: 2px solid red; padding: 5px;"><p style="text-align: center;">○</p><p style="text-align: center;">ATTENTION!</p><p>Do not tighten the 6 X bolts that mounts to cone flange to top of drum lid until you have perfectly aligned the drum lid up parallel to the uprights. This ingenious design allows you to swivel the drum lid about 30 degrees +/- Failure to do so will make the drum unable to fit in space between vertical uprights.</p></div>	<p>28. Apply foam tape to the cone flange before attaching the drum lid. Secure the Octagon drum lid to the cyclone funnel using (6) 5/16" x 3/4" hex bolts, (12) 5/16" x 1" flat washers and (6) 5/16" hex nuts. Make sure to first attach all the bolts before tightening. NOTE: The lid will turn when the bolts have not been tightened for alignment. Failure to do will result in the drum lid not being able to align with the drum.</p>
 <p>Crossbar</p>	<p>29. Attach the crossbar to the drum lid and tighten using the two bolts removed in the previous step. It does not matter which position you attach the crossbar.</p>

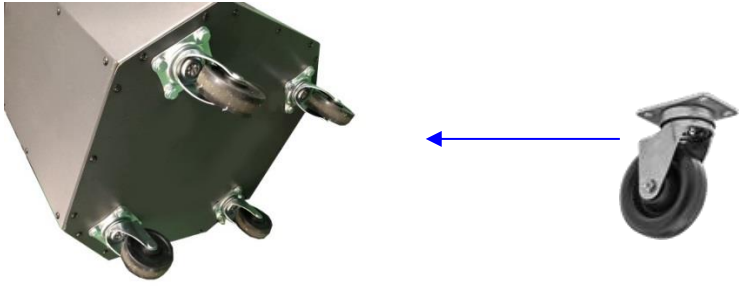
LAGUNA

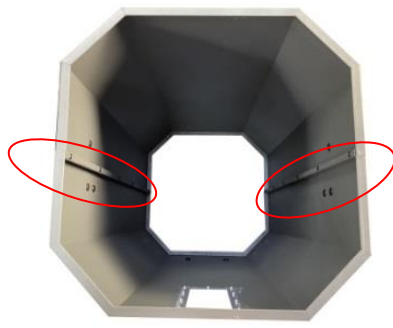
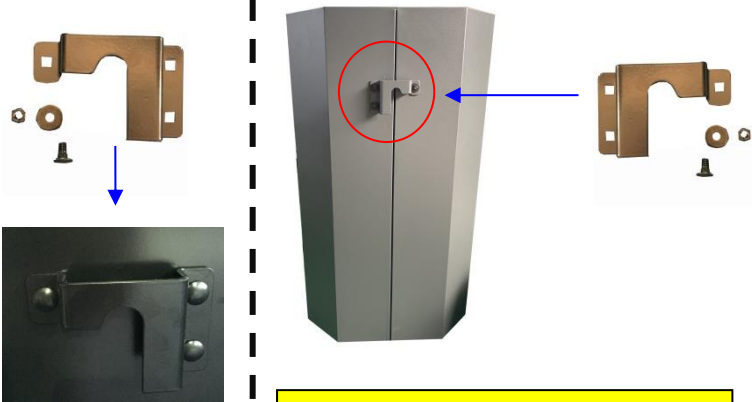
	<p>30. Assemble the Octagon drum. Locate the drum base panel (it does not matter which side faces inside) and secure the (4) casters using (16) 5/16" x 3/4" hex bolts, (32) 5/16" x 1" flat washers and (16) 5/16" hex nuts.</p>
	<p>31. Attach the handles to the top and bottom end on the front panel with the window display using (4) flat head Philips bolts, (4) 5/16" x 7/8" flat washers and (4) 5/16" hex nuts. Note that the head of the Philip bolt must be inserted from the handle with the hex nut and washer on the inside of the drum.</p>
	<p>32. Assemble the Octagon Drum front and back panels using (12) M4 x 12mm sheet metal screws.</p>
 <p style="text-align: center;">View of right side of panels</p>	<p>33. On the left and right side you will find three bolt holes. Take the matching side plate and secure to the outside of the panel using (6) 1/4" x 1/2" carriage bolts, (6) 1/4" x 1" flat washers and (6) 1/4" hex nuts. Insert the head of the carriage bolt from the inside of the drum with the washers and nuts on the outside of the drum.</p>

LAGUNA

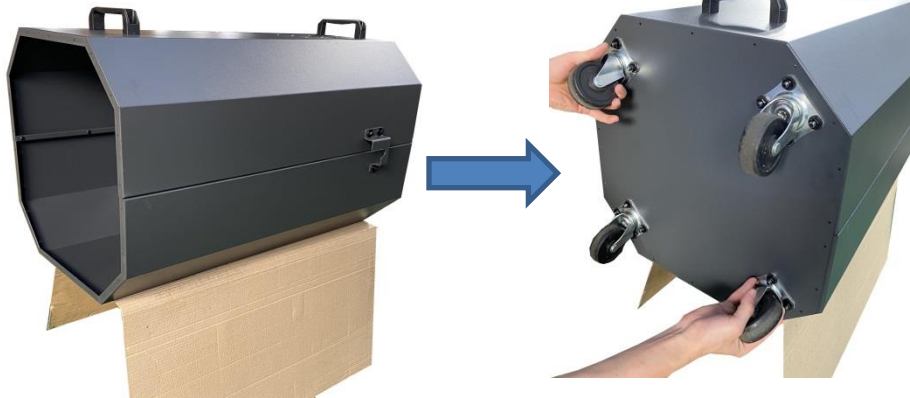

34. Place the drum on its side with the handle facing top. With the help of another person, hold the base panel with wheels up against the base of the drum. Using (22) M3 x 6mm Philips flat point screws and M3 cap nuts secure and fasten tightly. **Make sure the head of the Philip screw is on the inside of the drum.** The cap nut is secured from the outside. Otherwise, this will cause for air leakage regardless of silicone being applied.



35. With the drum laying on its side to apply silicone to the inside of the drum including the base and the top rim of the drum before the rubber gasket has been attached to seal and prevent air leakages. You will need to use a caulking gun (not supplied).

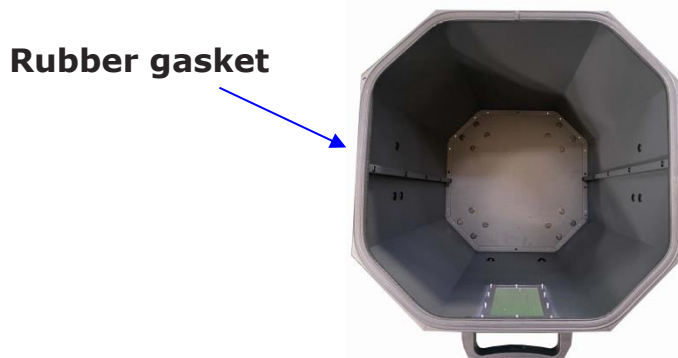

36. Attach the rubber gasket to the top inner edges of the Octagon drum. The wider end of the gasket goes up. Use tin snips/scissors to trim any excess rubber gasket after completing the seal.



37. Insert the plastic debris collection bag inside the Octagon drum. Open and spread out the plastic bag to the corners and edges.

LAGUNA

Drum insert

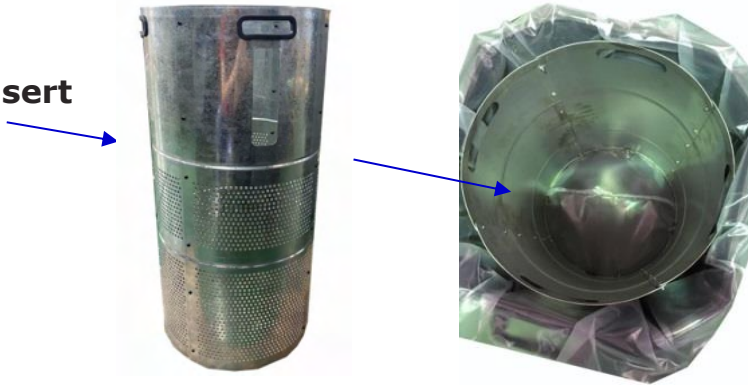

38. Use (24) Round-head Philip bolts $3/16'' \times 1/2''$ and (24) Cap nuts ($3/16''$) to assemble the drum insert together. Place the drum insert inside over the plastic bag in the Octagon drum.



39. Lift the foot pedal bar. Align the Octagon drum window to the center point of the drum lid and push the drum in. Lower the foot pedal bar to seal the drum tight for normal machine operation.

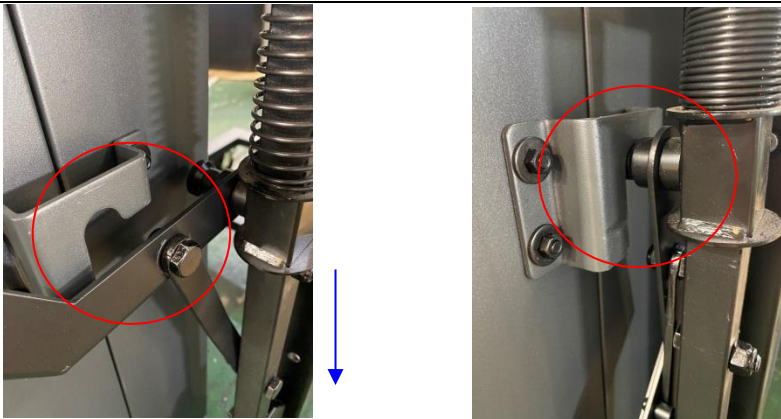

40. Make sure when aligning the drum that both the left and right-side lift plates are over the topping on the foot pedal bar assembly before lifting the foot pedal bar up. When not aligned, the drum will not be fully sealed and will interfere with air flow.

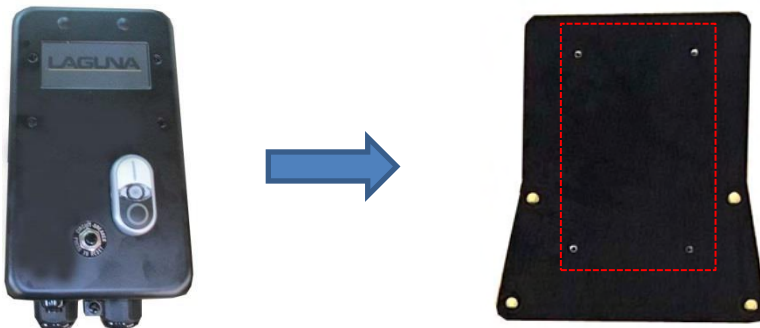

41. Open the Switch Box by removing the bolt at the bottom of the switch box to mount to the switch base plate using (4) $3/8'' \times 1''$ hex bolts, (8) $3/8''$ flat washers and (4) $3/8''$ hex nuts.

LAGUNA

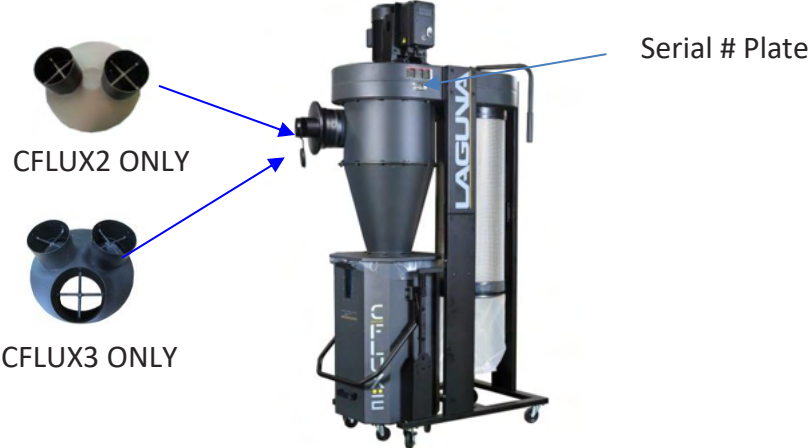
	<p>42. Install the Switch Box assembly on the motor support base using (4) 1/4" x 3/4" hex bolts, (4) 1/4" x 1" flat washers and (4) 3/8" lock washers.</p>
	<p>43. Install the intake splitter to the intake using (3) M4 x 12mm sheet metal screws. Attach the rubber caps to each 4" port.</p> <p>All the assembly steps have been completed.</p>

POWER SUPPLY

Power Supply Circuit Requirements

The power source circuit for your machine must be grounded and rated for the amperage given below. Never replace a circuit breaker on an existing circuit with one of higher amperage without consulting a qualified electrician to ensure compliance with local wiring codes. **If you are unsure about the wiring codes in your area or you plan to connect your machine to a shared circuit, consult a qualified electrician.**

CFLUX2 (2HP/220V/60HZ/Single phase) Circuit Size (220V) ... 20 Amp minimum
CFLUX3 (3HP/220V/60HZ/Single phase) Circuit Size (220V) 30 Amp minimum



IN ALL CASES, MAKE CERTAIN THE RECEPTACLE IN QUESTION IS PROPERLY GROUNDED. IF YOU ARE NOT SURE, HAVE A QUALIFIED ELECTRICIAN CHECK THE RECEPTACLE.



220 VOLT Single-Phase Operation

The motor supplied with your machine is a 220 Volt motor. It is shipped ready-to-run for 220 Volt operation.

NOTE: An (appx.) 8' cord is included and can be used for 220 Volt operation. A "plug" is NOT included and must be installed by a qualified technician.

OPERATION

1. Make sure at least one blast gate is open, if connected to a dust collection system with blast gates.

CAUTION

Never operate dust collector with all blast gates closed!

2. Confirm the electrical supply is correct and connected to machine.
3. Make sure no one is working on or doing maintenance to dust collector.
4. To start, press the ON button on either the ON/OFF switch (Fig. 39) or remote control, (Fig. 40).
5. To stop, press the OFF button on either the ON/OFF switch (Fig. 39) or remote control, (Fig. 40).

MAINTENANCE

CLEANING THE FILTER

To ensure proper operation of this Mobile Dust Cyclone, the HEPA canister filter must have adequate air flow. This means the filter must be regularly maintained by carefully blowing the filter clean using compressed air and an air gun to release built-up particulates trapped between the filter pleats.

For heavy duty users, it is recommended to use compressed air on a regular basis to maintain maximum filtration efficiency and longer life span of the filter.

Using the Filter Cleaner Crank

The filter cleaner crank knocks dust particulate and small debris from the pleated filter and into the filter bag.

To keep your machine in go working condition, it is recommended that you use the filter cleaner crank to clean the filter after every use.

To clean the filter using the crank simply rotate the crank handle clockwise four or five rotations.

Using Compressed Air



DISCONNECT MACHINE FROM POWER!

For heavy duty users, it is recommended to use compressed air on a weekly basis to maintain maximum filtration efficiency and longer life span of the filter.

REMOVING THE CANISTER FILTER

1. Release the spring-loaded band clamp at the bottom of the canister filter and remove the plastic bag.



Figure 7: Releasing filter clamp

2. While supporting the canister filter assembly from the bottom, release the spring-loaded band clamp from the top of the canister filter assembly.



Figure 8: Hold canister from bottom when releasing clamp

3. Remove the (4) 3/16" x 3/4" sheet metal Philip bolts, (1) 5/16" x 3/4" hex bolt and (1) 5/16" x 7/8" flat washer off the bottom of the canister filter.
4. Remove the canister filter and carefully tilt the top of the canister filter assembly to clear the paddle branches. Slightly bend the paddle branches to remove the canister filter.



NOTE: You may have to gently bend the paddles to free the canister filter. This should not adversely affect the operation of the machine.

5. With the canister filter removed use a compressed air gun to thoroughly clean between the pleats, both inside and outside.

RE-ASSEMBLING THE CANISTER FILTER AFTER CLEANING

1. With the aid of another person, carefully re-insert the canister filter repeating step 1,2,3 and 4 in reverse.

EMPTYING OR REPLACING THE FILTER BAG

Periodically check the filter bag, if it is more than one third full, it is recommended that you empty it.

NOTE: If the filter bag gets too full, the weight may force it to pull away from the band clamp, exposing the user to potentially harmful particulates.

1. Release the spring-loaded band clamp at the bottom of the filter and remove the filter bag.
2. Empty or replace the filter bag and re-attach using the spring-loaded band clamp.

EMPTYING THE DRUM

Periodically inspect the contents of the drum and empty as needed. To inspect the contents of the drum:

1. Raise the drum foot pedal bar to lower the drum to the floor.
2. Roll it away from the machine, inspect and empty as needed.

ROUTINE INSPECTION

It is a good idea to routinely inspect quality woodworking tools in order to keep them in optimum condition. This includes inspecting all hardware for tightness, ensuring the filter is clean, and cleaning debris and grime from any surface and moving parts.



TROUBLESHOOTING

Symptom	Possible Cause	Possible Solution
Machine does not start or a breaker trips.	Power supply switched OFF or is faulty.	Confirm power supply is ON and has the correct voltage.
	Wall fuse/circuit breaker is blown/tripped.	Ensure adequate circuit size; install inlet restrictor, replace weak breaker.
	Faulty remote control.	Replace batteries; ensure unobstructed line-of-sight and signal range.
	Remote receiver is faulty.	Inspect receiver circuit board; replace if faulty.
	Incorrectly wired motor connection.	Rewire or call certified service technician or electrician.
	On-board circuit breaker is tripped.	Allow motor to cool, improve ventilation, press reset button.
	Wiring is open/has high resistance.	Check for broken wires or poor connections, repair as necessary.
Excessive vibration or noise during operation.	Faulty power switch.	Replace switch.
	Motor is at fault.	Test/repair/replace.
	Loose component.	Inspect and tighten all bolts/nuts.
	Loose or broken motor mount.	Tighten or replace as needed.
	Motor fan hitting fan cover.	Check fan and cover; replace as needed.
	Bad motor bearings.	Rotate shaft manually, check for grinding or loose shaft, replace bearings if needed.

LAGUNA

<p>Loud, repetitive noise, or excessive vibration coming from cyclone</p>	<p>Machine is on uneven surface.</p> <p>Damaged/Unbalanced impeller.</p> <p>Loose connections.</p> <p>Impeller is loose.</p> <p>Motor fan hitting fan cover.</p>	<p>Stabilize on a flat surface.</p> <p>Inspect impeller for dents, bends, loose fins. Replace if needed.</p> <p>Check and re-tighten all fasteners.</p> <p>Replace the motor and impeller.</p> <p>Check fan and cover; replace as needed.</p>
<p>Dust cyclone does not adequately collect dust or chips; poor performance.</p>	<p>Canister end cap is full.</p> <p>Filter is dirty.</p> <p>Restricted duct line.</p> <p>Suction route is too long or has too many sharp bends.</p> <p>Wet lumber is clogging ducts.</p> <p>Leaks in the duct work or too many open ports.</p> <p>Inadequate velocity in the main suction line.</p> <p>Wrong size ducting/ports used.</p>	<p>Empty canister end cap.</p> <p>Clean filter.</p> <p>Clean inlet splitter.</p> <p>Move machine closer to the point of suction, and rerun ducts to eliminate sharp bends.</p> <p>Use lumber with less than 20% moisture content.</p> <p>Repair all duct leaks and close any ports not being used.</p> <p>Increase velocity by opening 1 or 2 more blast gates to different branch lines.</p> <p>Re-size and re-install ducts and fittings.</p>
<p>Sawdust being blown into the air from the dust cyclone</p>	<p>Band clamp or end cap is not secure.</p> <p>Loose or damaged seals.</p>	<p>Re-install ensuring a tight fit.</p> <p>Replace seals and gaskets.</p>

LAGUNA

Parts Breakdown CFLUX 2 & 3

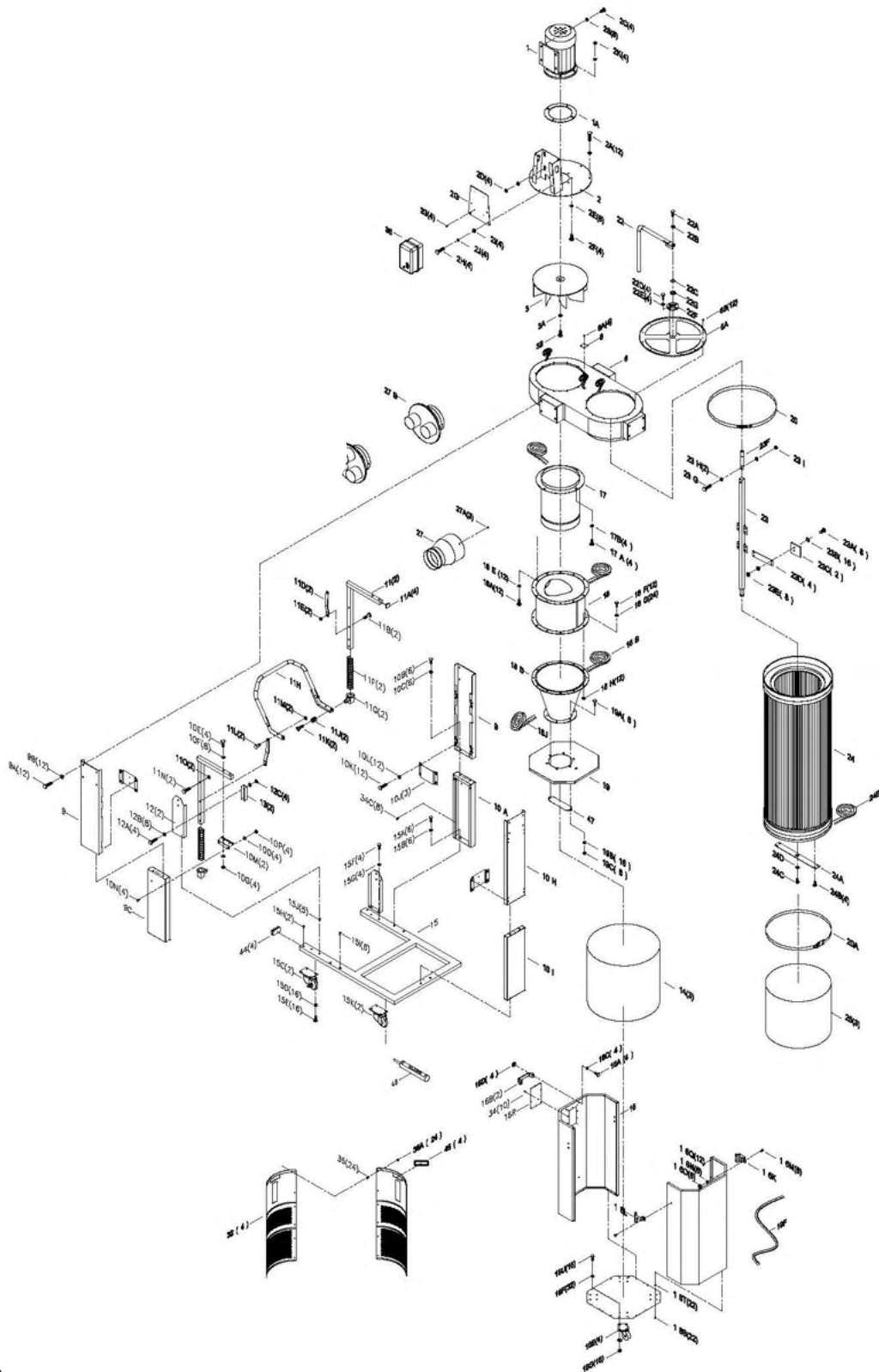

Fig. 9

SECTION A
(Close up view)

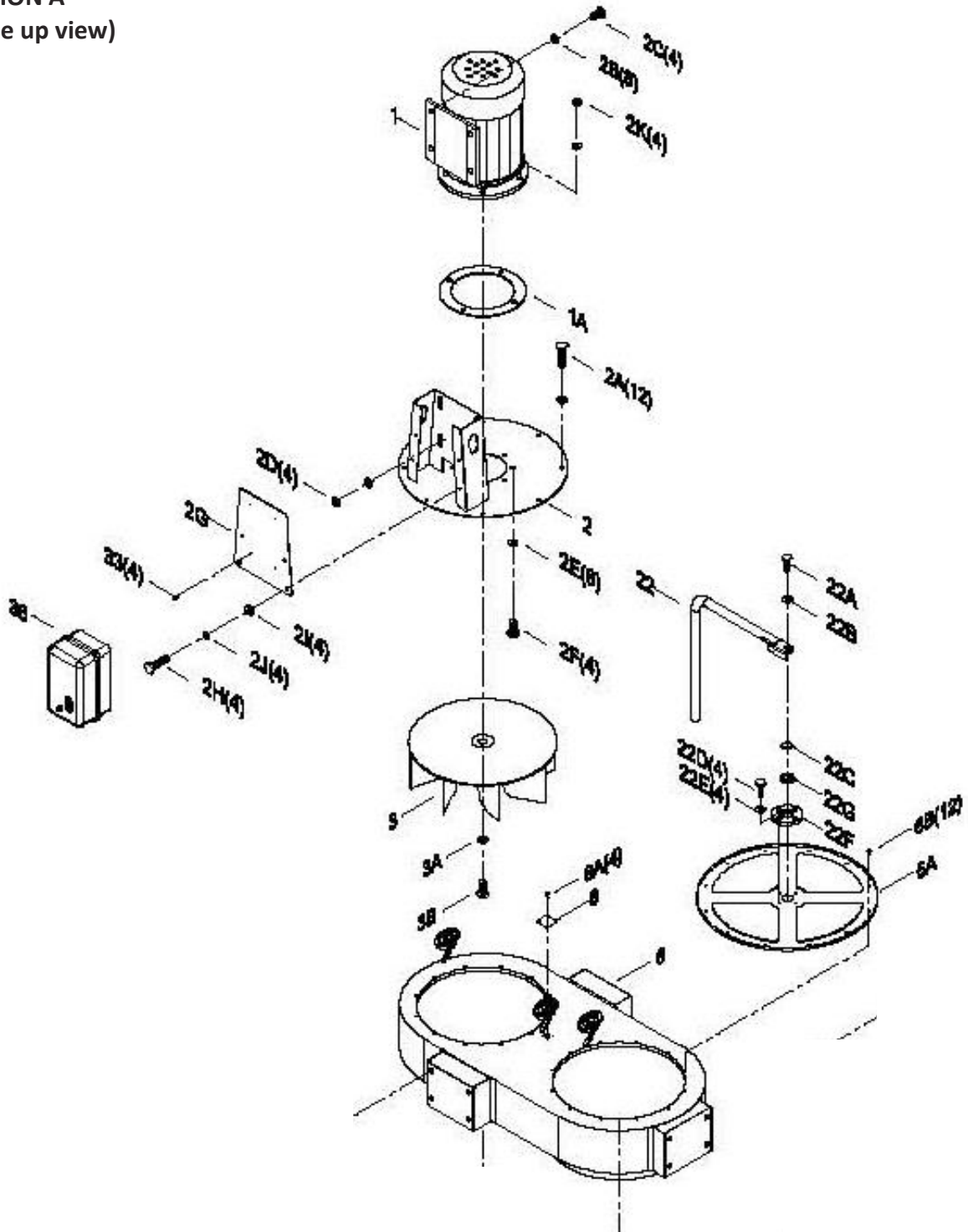

Figure 10: Fan, Motor & Switch

SECTION B (Close up view)

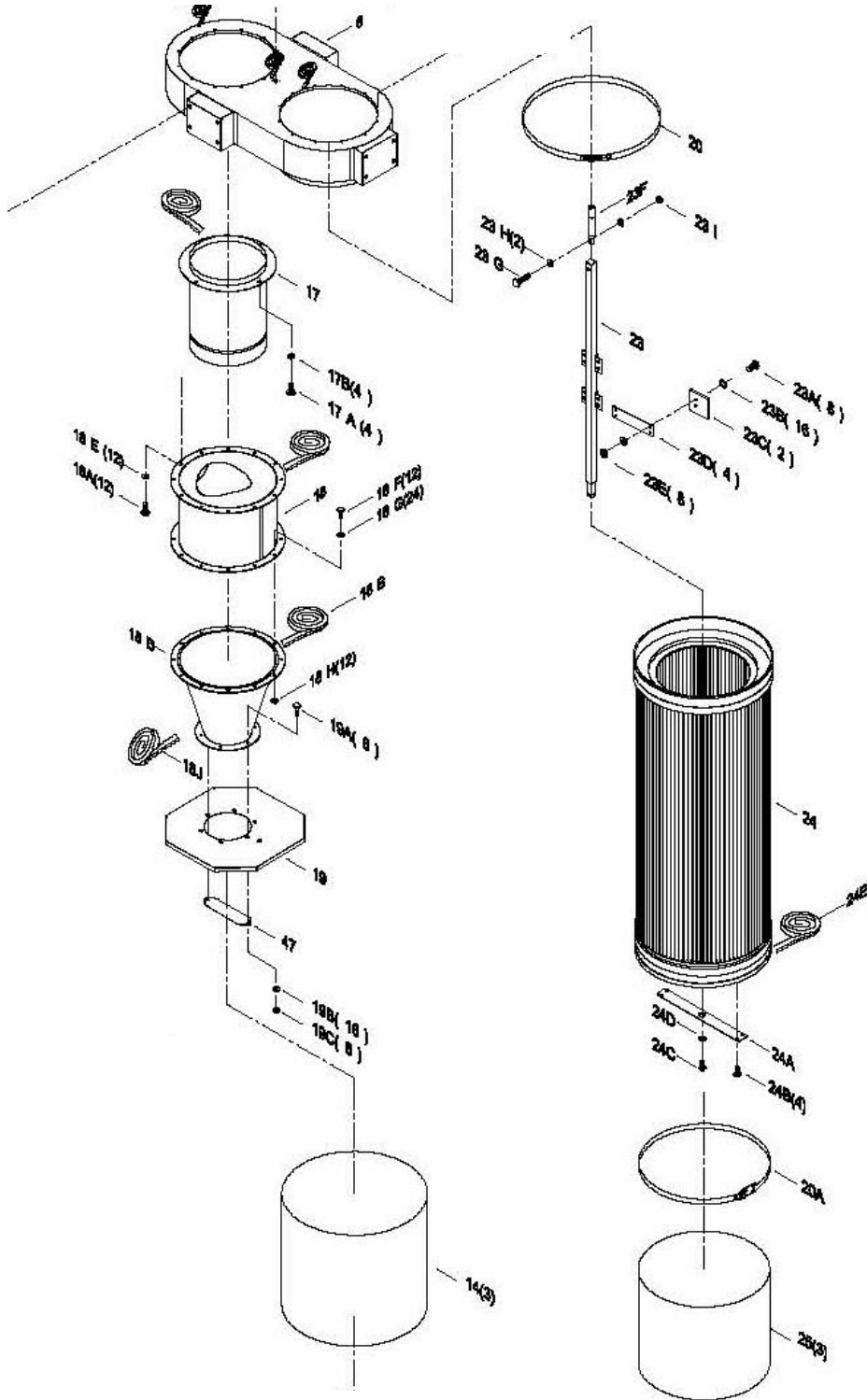

Figure 11: Cyclone, Canister & Barrel

SECTION C (Close up view)

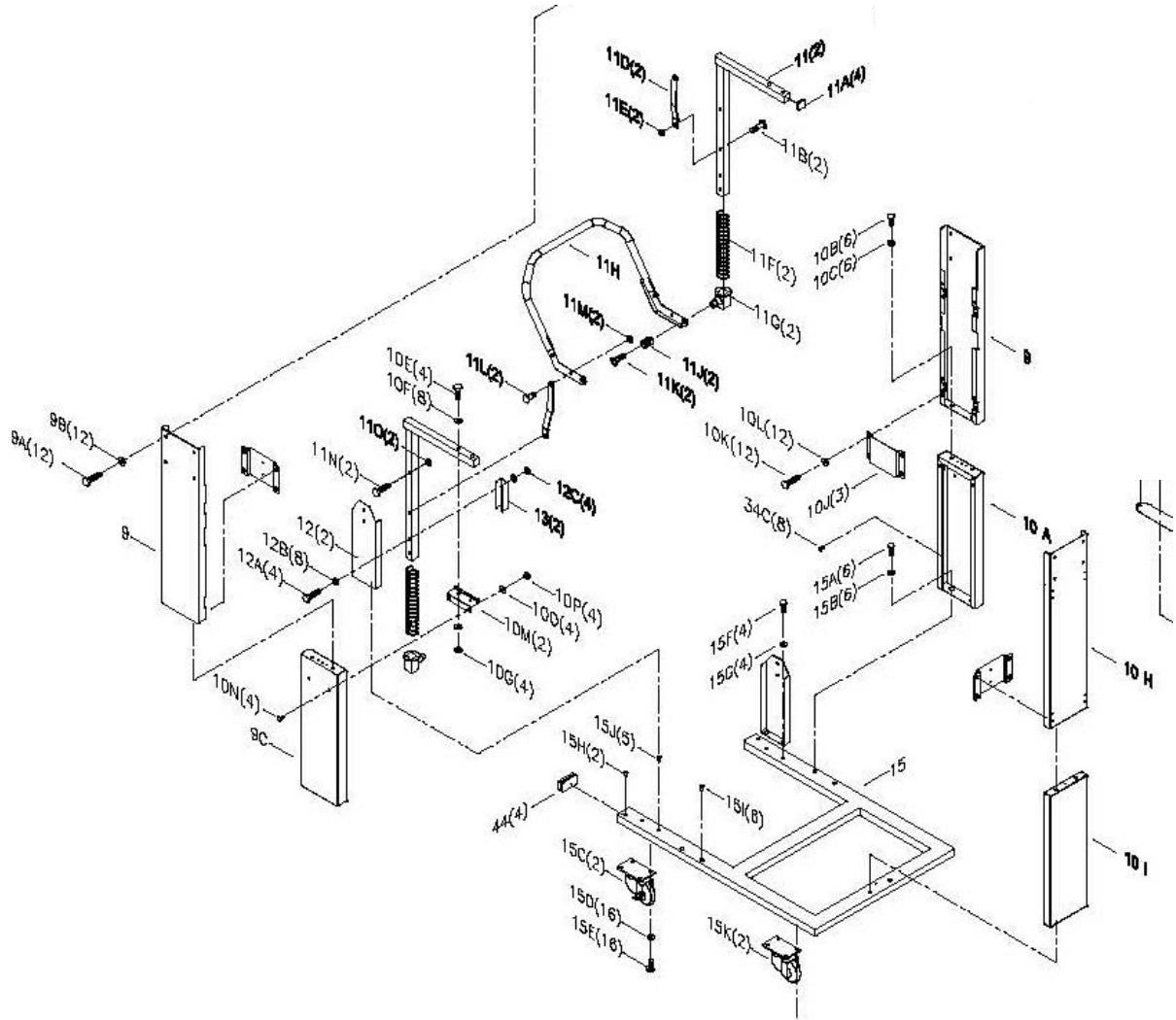

Figure 12: Panels & Lock

SECTION D (Close up view)

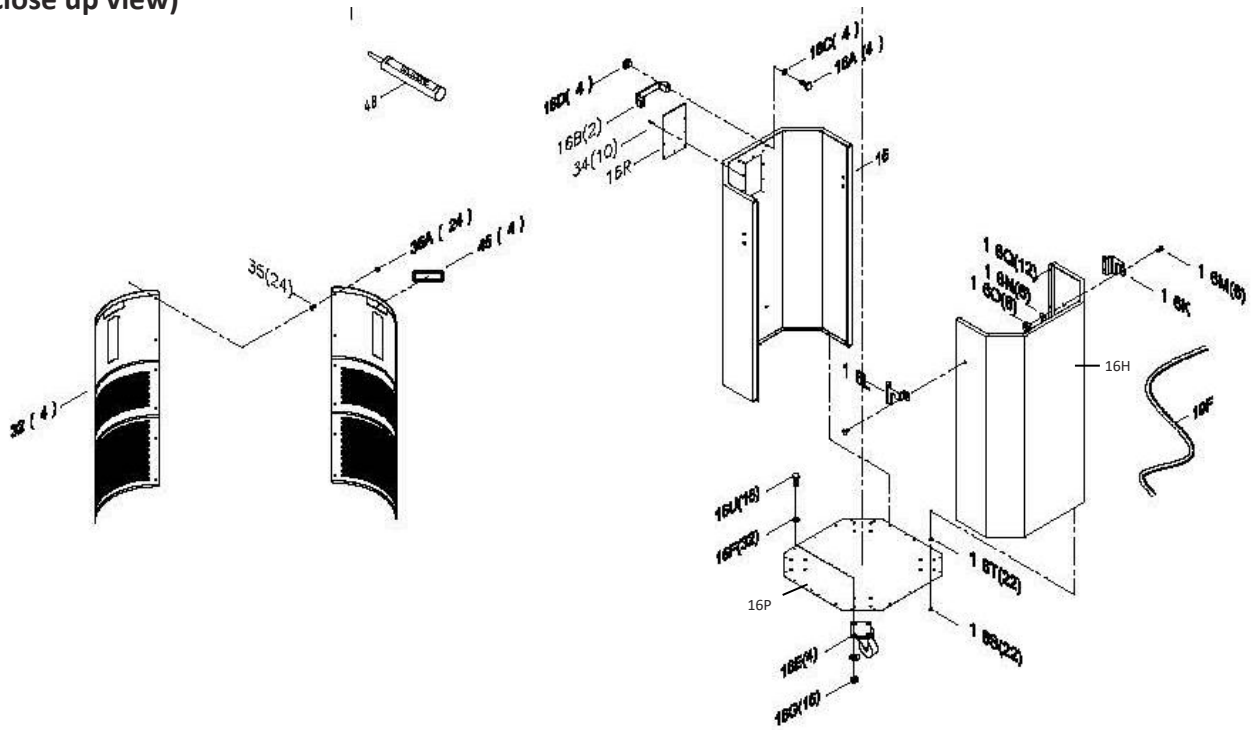

Figure 13: Barrel & insert



Parts List CFLUX2

No.	Part Number	Description	QTY	No.	Part Number	Description	QTY
1	PDCCF22201-1	MOTOR 2HP/220V/60Hz/1Ph	1	10B	PDCCF22201-10B	HEX BOLT 5/16" x 3/4"	6
1A	PDCCF22201-1A	MOTOR GASKET	1	10C	PDCCF22201-10C	FLAT WASHER 5/16"x18x2mm	6
2	PDCCF22201-2	MOTOR SUPPORT BASE	1	10E	PDCCF22201-10E	HEX BOLT 5/16" x 1-3/4"	4
2A	PDCCF22201-2A	HEX LOCK BOLT 5/16" x 5/8"	12	10F	PDCCF22201-10F	FLAT WASHER 5/16"x18x2mm	8
2B	PDCCF22201-2B	FLAT WASHER 3/8"x23x2mm	8	10G	PDCCF22201-10G	HEX NUT 5/16"	4
2C	PDCCF22201-2C	HEX BOLT 3/8" x 1"	4	10H	PDCCF22201-10H	TOP UPRIGHT SUPPORT ONE DOT (1A)	1
2D	PDCCF22201-2D	HEX NUT 3/8"	4	10I	PDCCF22201-10IV2	LOWER UPRIGHT SUPPORT ONE DOT (1B) 235V2.2021	1
2E	PDCCF22201-2E	FLAT WASHER 3/8"x23x2mm	4	10J	PDCCF22201-10J	UPRIGHT SUPPORT REINFORCEMENT PLATE	3
2F	PDCCF22201-2F	HEX BOLT 3/8" x 1-1/4"	4	10K	PDCCF22201-10K	HEX BOLT 5/16" x 3/4"	12
2G	PDCCF22201-2G	SWITCH PLATE	1	10L	PDCCF22201-10L	FLAT WASHER 5/16"x18x2mm	12
2H	PDCCF22201-2H	HEX BOLT 1/4" x 3/4"	4	10M	PDCCF22201-10M	FOOT-PEDAL BAR SUPPORT	2
2I	PDCCF22201-2I	FLAT WASHER 1/4"x19x1mm	4	10N	PDCCF22201-10N	CARRIAGE BOLT 5/16"x1/2"	4
3	PDCCF22201-3	FAN 14.5"	1	10O	PDCCF22201-10O	CARRIAGE BOLT 5/16"x18x2mm	4
3A	PDCCF22201-3A	FLAT WASHER 3/8"x45x3t	1	10P	PDCCF22201-10P	HEX NUT 5/16"	4
3B	PDCCF22201-3B	HEX BOLT 3/8" x 1"	1	11	PDCCF22201-11	FOOT-PEDAL BAR	2
6	PDCCF22201-6	DUST CHUTE	1	11A	PDCCF22201-11A	PLUG 25, 25	4
6A	PDCCF22201-6A	CANISTER COVER PLATE	1	11B	PDCCF22201-11B	HEX BOLT 3/8"	2
6B	PDCCF22201-6B	SHEET METAL THREAD BOLT 3/16" x 1/2"	12	11D	PDCCF22201-11D	MOVEABLE SUPPORT BRACE	2
8	PDCCF22201-8	COVER PLATE	1	11E	PDCCF22201-11E	HEX LOCK NUT 3/8"	2
8A	PDCCF22201-8A	SHEET METAL THREAD BOLT M4x12mm	4	11F	PDCCF22201-11F	SPRING Ø42mm x 242mm	2
9	PDCCF22201-9V2	TOP UPRIGHT SUPPORT V2.2021	2	11G	PDCCF22201-11G	SKID BLOCK	2
9A	PDCCF22201-9A	HEX BOLT 5/16" x 3/4"	12	11H	PDCCF22201-11H	OCTAGON DRUM FOOT-PEDAL	1
9B	PDCCF22201-9A	FLAT WASHER 5/16"x18x2mm	12	11J	PDCCF22201-11J	TOPPING Ø24mmx30mm	2
9C	PDCCF22201-9CV2	LOWER UPRIGHT SUPPORT TWO DOT (3B)235 V2.2021	1	11K	PDCCF22201-11K	HEX BOLT M8 x 30mm	2
10A	PDCCF22201-10AV2	LOWER UPRIGHT SUPPORT THREE DOT (2B) 235 V2.2021	1	11L	PDCCF22201-11L	HEX BOLT 3/8"	2

LAGUNA

No.	Part Number	Description	QTY	No.	Part Number	Description	QTY
11M	PDCCF22201-11M	HEX LOCK NUT 3/8"	2	16E	PDCCF22201-16E	DRUM CASTER 3"	4
11N	PDCCF22201-11N	HEX BOLT 3/8" x 1-1/2"	2	16U	PDCCF22201-16U	HEX BOLT 5/16" x 3/4"	16
11O	PDCCF22201-11O	HEX LOCK NUT 3/8"	2	16F	PDCCF22201-16F	FLAT WASHER 5/16"x18x2mm	32
12	PDCCF22201-12V2	TRIANGULAR SUPPORT PLATE V2.2021	2	16G	PDCCF22201-16G	HEX NUT 5/16"	16
12A	PDCCF22201-12A	HEX BOLT 5/16" x 1-3/4"	4	16H	PDCCF22201-16HV2	OCTAGON DRUM BACK PANEL V2.2021	1
12B	PDCCF22201-12B	FLAT WASHER 5/16"x18x2mm	8	16K	PDCCF22201-16K	LEFT SIDE PLATE	1
12C	PDCCF22201-12C	HEX NUT 5/16"	4	16L	PDCCF22201-16L	RIGHT SIDE PLATE	1
13	PDCCF22201-13	LOWER SUPPORT PLATE	2	16M	PDCCF22201-16M	CARRIAGE BOLT 1/4" x 1/2"	6
14	PDCCF22201-14V2	PLASTIC BAG Ø610 x 1200mm	3	16N	PDCCF22201-16N	FLAT WASHER 1/4"x19x2mm	6
15	PDCCF22201-15	BASE	1	16O	PDCCF22201-16O	HEX NUT 1/4"	6
15A	PDCCF22201-15A	HEX BOLT 3/8" x 3/4"	6	16P	PDCCF22201-16PV2	OCTAGON DRUM BASE PANEL V2.2021	1
15B	PDCCF22201-15B	FLAT WASHER 3/8" x 23 x 2mm	6	16R	PDCCF22201-16RV2	WINDOW V2.2021	1
15C	PDCCF22201-15C	SWIVEL CASTER 4"	2	16S	PDCCF22201-16S	TRUSS HEAD PHILIPS FLAT POINT SCREWS M3 x 6mm	22
15D	PDCCF22201-15D	FLAT WASHER 5/16"x18x2mm	16	16T	PDCCF22201-16T	CAP NUT M3	22
15E	PDCCF22201-15E	HEX BOLT 5/16" x 3/4"	16	16Q	PDCCF22201-16Q	THREAD BOLT M4 x 12mm	10
15F	PDCCF22201-15F	HEX BOLT 5/16" x 3/4"	4	17	PDCCF22201-17	INTAKE CYLINDER	1
15G	PDCCF22201-15G	FLAT WASHER 5/16"x18x2mm	4	17A	PDCCF22201-17A	HEX BOLT 5/16" x 5/8"	4
15H	PDCCF22201-15H	RIVET NUT 1/4"	2	17B	PDCCF22201-17B	FLAT WASHER 5/16"x18x2mm	4
15I	PDCCF22201-15I	RIVET NUT 3/8"	6	18	PDCCF22201-18	CYCLONE BARREL	1
15J	PDCCF22201-15J	RIVET NUT 5/16"	5	18A	PDCCF22201-18A	HEX BOLT 5/16" x 3/4"	12
15K	PDCCF22201-15K	SWIVEL CASTER W/BRAKES 4"	2	18B	PDCCF22201-18B	FOAM TAPE 3 x 6mm x 10M	1
16	PDCCF22201-16V2	OCTAGON DRUM FRONT PANEL V2.2021	1	18D	PDCCF22201-18D	CYCLONE FUNNEL	1
16A	PDCCF22201-16A	FLAT HEAD PHILIP BOLT 5/16"x3/4"	4	18E	PDCCF22201-18E	FLAT WASHER 5/16"x18x2t	12
16B	PDCCF22201-16B	HANDLE	2	18F	PDCCF22201-18F	HEX BOLT 5/16" x 3/4"	12
16C	PDCCF22201-16C	FLAT WASHER 5/16"x23x2mm	4	18G	PDCCF22201-18G	FLAT WASHER 5/16"x18x2mm	24
16D	PDCCF22201-16D	HEX NUT 5/16"	4	18H	PDCCF22201-18H	HEX NUT 5/16"	12

LAGUNA

No.	Part Number	Description	QTY	No.	Part Number	Description	QTY
18J	FOAM TAPE	3x15mm x 80CM	1	23H	PDCCF22201-23H	FLAT WASHER 5/16"x18x2mm	2
19	PDCCF22201-19V2	OCTAGON DRUM LID V2.2021	1	23I	PDCCF22201-23I	HEX LOCK NUT 5/16"	1
19A	PDCCF22201-19A	HEX BOLT 5/16" x 3/4"	6	24	PDCCF22201-24	CANISTER FILTER Ø400mm x 900mm	1
19B	PDCCF22201-19B	FLAT WASHER 5/16" x 18 x 2	12	24A	PDCCF22201-24A	ROTATION SHAFT BASE	1
19C	PDCCF22201-19C	HEX NUT 5/16"	6	24B	PDCCF22201-24B	SHEET METAL PHILIP BOLT 3/16" x 3/4"	4
19D	PDCCF22201-19D	PLUG MSP-16	1	24C	PDCCF22201-24C	HEX BOLT 5/16" x 3/4"	1
19E	PDCCF22201-19E	NUT AGL-16	1	24D	PDCCF22201-24D	FLAT WASHER 5/16" x 23 x 2	1
19F	PDCCF22201-19F	RUBBER GASKET 1650mm	1	24E	PDCCF22201-24E	FOAM TAPE 3 x 25mm x 1.5M	1
20	PDCCF22201-20	BAND CLAMP Ø400mm	1	25	PDCCF22201-25	PLASTIC BAG Ø400mm x 600mm	3
20A	PDCCF22201-20A	SPRING BAND CLAMP Ø400mm	1	27	PDCCF22201-27	INTAKE REDUCER 8" BY 6"	1
22	PDCCF22201-22	ROTATION CRANK	1	27A	PDCCF22201-27A	SHEET METAL BOLT M4 x 12mm	3
22A	PDCCF22201-22A	HEX BOLT 5/16" x 3/4"	1	27B	PDCCF22201-27B	INTAKE SPLITTER 8" x 4" x 2	1
22B	PDCCF22201-22B	FLAT WASHER 5/16"x30x3mm	1				
22C	PDCCF22201-22C	GEAR Ø20mm	1	32	PDCCF22201-32V2	DRUM INSERT V2.2021	4
22D	PDCCF22201-22D	HEX BOLT 1/4" x 3/4"	4	33	PDCCF22201-33	FLAT HEAD BOLT M4 x 6mm	4
22E	PDCCF22201-22E	FLAT WASHER 1/4" x 19 x2mm	4	34	PDCCF22201-34	RIVET 3-2	10
22F	PDCCF22201-22F	BEARING	1	34C	PDCCF22201-34C	RIVET NUT 1/4"	8
22G	PDCCF22201-22G	SEAL	1	34D	PDCCF22201-34D	RIVET NUT 5/16"	18
23	PDCCF22201-23V2	ROTATION SHAFT V2.2021	1	35	PDCCF22201-35	ROUND HD BOLT 3/16" x 1/2"	24
23A	PDCCF22201-23A	HEX BOLT 1/4" x 5/8"	8	35A	PDCCF22201-35A	NUT 3/16"	24
23B	PDCCF22201-23B	FLAT WASHER 1/4" x 13mm x 1mm	16	36	PDCCF22201-36V2	FREQUENCY REMOTE SWITCH V2.2021	1
23C	PDCCF22201-23C	PADDLE	2	44	PDCCF22201-44	RUBBER PLUG 30mm x 60mm	4
23D	PDCCF22201-23D	PADDLE BRANCH	4	47	PDCCF22201-47	CROSSBAR	1
23E	PDCCF22201-23E	HEX LOCK NUT 1/4"	8	48	PDCCF22201-48	SILICONE	1
23F	PDCCF22201-23F	ROTATION SHAFT CONNECTION	1				
23G	PDCCF22201-23G	HEX BOLT 5/16" x 1-1/2"	1				



Parts List CFLUX3

No.	Part Number	Description	QTY	No.	Part Number	Description	QTY
1	PDCCF32201-1	MOTOR 3HP/220V/60Hz/1Ph	1	10B	PDCCF32201-10B	HEX BOLT 5/16" x 3/4"	6
1A	PDCCF32201-1A	MOTOR GASKET	1	10C	PDCCF32201-10C	FLAT WASHER 5/16"x18x2t	6
2	PDCCF32201-2	MOTOR SUPPORT BASE	1	10E	PDCCF32201-10E	HEX BOLT 5/16" x 1-3/4"	4
2A	PDCCF32201-2A	HEX LOCK BOLT 5/16" x 5/8"	12	10F	PDCCF32201-10F	FLAT WASHER 5/16"x18x2t	8
2B	PDCCF32201-2B	FLAT WASHER 3/8"x23x2t"	8	10G	PDCCF32201-10G	HEX NUT 5/16"	4
2C	PDCCF32201-2C	HEX BOLT 3/8" x 1"	4	10H	PDCCF32201-10H	TOP UPRIGHT SUPPORT ONE DOT (1A)	1
2D	PDCCF32201-2D	HEX NUT 3/8"	4	10I	PDCCF32201-10I	LOWER UPRIGHT SUPPORT ONE DOT (1B) 235V2.2021	1
2E	PDCCF32201-2E	FLAT WASHER 3/8"x23x2mm	4	10J	PDCCF32201-10J	UPRIGHT SUPPORT REINFORCEMENT PLATE	3
2F	PDCCF32201-2F	HEX BOLT 3/8" x 1-1/4"	4	10K	PDCCF32201-10K	HEX BOLT 5/16" x 3/4"	12
2G	PDCCF32201-2G	SWITCH PLATE	1	10L	PDCCF32201-10L	FLAT WASHER 5/16"x18x2mm	12
2H	PDCCF32201-2H	HEX BOLT 1/4" x 3/4"	4	10M	PDCCF32201-10M	FOOT-PEDAL BAR SUPPORT	2
2I	PDCCF32201-2I	FLAT WASHER 1/4"x19x1mm	4	10N	PDCCF32201-10N	CARRIAGE BOLT 5/16"x1/2"	4
3	PDCCF32201-3	FAN 15.5"	1	10O	PDCCF32201-10O	CARRIAGE BOLT 5/16"x18x2mm	4
3A	PDCCF32201-3A	FLAT WASHER 3/8"x45x3t	1	10P	PDCCF32201-10P	HEX NUT 5/16"	4
3B	PDCCF32201-3B	HEX BOLT 3/8" x 1"	1	11	PDCCF32201-11	FOOT PEDAL BAR	2
6	PDCCF32201-6	DUST CHUTE	1	11A	PDCCF32201-11A	PLUG 25, 25	4
6A	PDCCF32201-6A	CANISTER COVER PLATE	1	11B	PDCCF32201-11B	HEX BOLT 3/8"	2
6B	PDCCF32201-6B	SHEET METAL THREAD BOLT 3/16" x 1/2"	12	11D	PDCCF32201-11D	MOVEABLE SUPPORT BRACE	2
8	PDCCF32201-8	COVER PLATE	1	11E	PDCCF32201-11E	HEX LOCK NUT 3/8"	2
8A	PDCCF32201-8A	SHEET METAL THREAD BOLT M4x12mm	4	11F	PDCCF32201-11F	SPRING Ø42mm x 242mm	2
9	PDCCF32201-9V2	TOP UPRIGHT SUPPORT V2.2021	2	11G	PDCCF32201-11G	SKID BLOCK	2
9A	PDCCF32201-9A	HEX BOLT 5/16" x 3/4"	12	11H	PDCCF32201-11H	OCTAGON DRUM FOOT-PEDAL	1
9B	PDCCF32201-9A	FLAT WASHER 5/16"x18x2mm	12	11J	PDCCF32201-11J	TOPPING Ø24mmx30mm	2
9C	PDCCF32201-9CV2	LOWER UPRIGHT SUPPORT TWO DOT (3B)235 V2.2021	1	11K	PDCCF32201-11K	HEX BOLT M8 x 30mm	2
10A	PDCCF32201-10AV2	LOWER UPRIGHT SUPPORT THREE DOT (2B) 235 V2.2021	1	11L	PDCCF32201-11L	HEX BOLT 3/8"	2

LAGUNA

No.	Part Number	Description	QTY	No.	Part Number	Description	QTY
11M	PDCCF32201-11M	HEX LOCK NUT 3/8"	2	16E	PDCCF32201-16E	DRUM CASTER 3"	4
11N	PDCCF32201-11N	HEX BOLT 3/8" x 1-1/2"	2	16U	PDCCF32201-16U	HEX BOLT 5/16" x 3/4"	16
11O	PDCCF32201-11O	HEX LOCK NUT 3/8"	2	16F	PDCCF32201-16F	FLAT WASHER 5/16"x18x2mm	32
12	PDCCF32201-12V2	TRIANGULAR SUPPORT PLATE V2.2021	2	16G	PDCCF32201-16G	HEX NUT 5/16"	16
12A	PDCCF32201-12A	HEX BOLT 5/16" x 1-3/4"	4	16H	PDCCF32201-16HV2	OCTAGON DRUM BACK PANEL V2.2021	1
12B	PDCCF32201-12B	FLAT WASHER 5/16"x18x2mm	8	16K	PDCCF32201-16K	LEFT SIDE PLATE	1
12C	PDCCF32201-12C	HEX NUT 5/16"	4	16L	PDCCF32201-16L	RIGHT SIDE PLATE	1
13	PDCCF32201-13	LOWER SUPPORT PLATE	2	16M	PDCCF32201-16M	CARRIAGE BOLT 1/4" x 1/2"	6
14	PDCCF32201-14V2	PLASTIC BAG Ø610 x 1200mm	3	16N	PDCCF32201-16N	FLAT WASHER 1/4"x19x2mm	6
15	PDCCF32201-15	BASE	1	16O	PDCCF32201-16O	HEX NUT 1/4"	6
15A	PDCCF32201-15A	HEX BOLT 3/8" x 3/4"	6	16P	PDCCF32201-16PV2	OCTAGON DRUM BASE PANEL V2.2021	1
15B	PDCCF32201-15B	FLAT WASHER 3/8" x 23 x 2mm	6	16R	PDCCF32201-16RV2	WINDOW V2.2021	1
15C	PDCCF32201-15C	SWIVEL CASTER 4"	2	16S	PDCCF32201-16S	TRUSS HEAD PHILIPS FLAT POINT SCREWS M3 x 6mm	22
15D	PDCCF32201-15D	FLAT WASHER 5/16"x18x2mm	16	16T	PDCCF32201-16T	CAP NUT M3	22
15E	PDCCF32201-15E	HEX BOLT 5/16" x 3/4"	16	16Q	PDCCF32201-16Q	THREAD BOLT M4 x 12mm	10
15F	PDCCF32201-15F	HEX BOLT 5/16" x 3/4"	4	17	PDCCF32201-17	INTAKE CYLINDER	1
15G	PDCCF32201-15G	FLAT WASHER 5/16"x18x2mm	4	17A	PDCCF32201-17A	HEX BOLT 5/16" x 5/8"	4
15H	PDCCF32201-15H	RIVET NUT 1/4"	2	17B	PDCCF32201-17B	FLAT WASHER 5/16"x18x2mm	4
15I	PDCCF32201-15I	RIVET NUT 3/8"	6	18	PDCCF32201-18	CYCLONE BARREL	1
15J	PDCCF32201-15J	RIVET NUT 5/16"	5	18A	PDCCF32201-18A	HEX BOLT 5/16" x 3/4"	12
15K	PDCCF32201-15K	SWIVEL CASTER W/BRAKES 4"	2	18B	PDCCF32201-18B	FOAM TAPE 3 x 6mm x 10M	1
16	PDCCF32201-16V2	OCTAGON DRUM FRONT PANEL V2.2021	1	18D	PDCCF32201-18D	CYCLONE FUNNEL	1
16A	PDCCF32201-16A	FLAT HEAD PHILIP BOLT 5/16"x3/4"	4	18E	PDCCF32201-18E	FLAT WASHER 5/16"x18x2mm	12
16B	PDCCF32201-16B	HANDLE	2	18F	PDCCF32201-18F	HEX BOLT 5/16" x 3/4"	12
16C	PDCCF32201-16C	FLAT WASHER 5/16"x23x2mm	4	18G	PDCCF32201-18G	FLAT WASHER 5/16"x18x2mm	24
16D	PDCCF32201-16D	HEX NUT 5/16"	4	18H	PDCCF32201-18H	HEX NUT 5/16"	12

LAGUNA

No.	Part Number	Description	QTY	No.	Part Number	Description	QTY
18J	PDCCF32201-18J	FOAM TAPE 3x15mm x 80CM	1	23H	PDCCF32201-23H	FLAT WASHER 5/16"x 18x 2mm	2
19	PDCCF32201-19V2	OCTAGON DRUM LID V2.2021	1	23I	PDCCF32201-23I	HEX LOCK NUT 5/16"	1
19A	PDCCF32201-19A	HEX BOLT 5/16" x 3/4"	6	24	PDCCF32201-24	CANISTER FILTER Ø400mm x 900mm	1
19B	PDCCF32201-19B	FLAT WASHER 5/16"x18x2mm	12	24A	PDCCF32201-24A	ROTATION SHAFT BASE	1
19C	PDCCF32201-19C	HEX NUT 5/16"	6	24B	PDCCF32201-24B	SHEET METAL PHILIP BOLT 3/16" x 3/4"	4
19D	PDCCF32201-19D	PLUG MSP-16	1	24C	PDCCF32201-24C	HEX BOLT 5/16" x 3/4"	1
19E	PDCCF32201-19E	NUT AGL-16	1	24D	PDCCF32201-24D	FLAT WASHER 5/16" x 23 x 2mm	1
19F	PDCCF32201-19F	RUBBER GASKET 1650mm	1	24E	PDCCF32201-24E	FOAM TAPE 3 x 25mm x 1.5M	1
20	PDCCF32201-20	BAND CLAMP Ø400mm	1	25	PDCCF32201-25	PLASTIC BAG Ø400mm x 600mm	3
20A	PDCCF32201-20A	SPRING BAND CLAMP Ø400mm	1				
22	PDCCF32201-22	ROTATION CRANK	1	27A	PDCCF32201-27A	SHEET METAL BOLT M4 x 12mm	3
22A	PDCCF32201-22A	HEX BOLT 5/16" x 3/4"	1				
22B	PDCCF32201-22B	FLAT WASHER 5/16"x30x3mm	1	27C	PDCCF32201-27C	INTAKE SPLITTER 8" x 4" X 3	1
22C	PDCCF32201-22C	GEAR Ø20mm	1	32	PDCCF32201-32V2	DRUM INSERT V2.2021	4
22D	PDCCF32201-22D	HEX BOLT 1/4" x 3/4"	4	33	PDCCF32201-33	FLAT HEAD BOLT M4 x 6mm	4
22E	PDCCF32201-22E	FLAT WASHER 1/4" x 19 x 2mm	4	34	PDCCF32201-34	RIVET 3-2	10
22F	PDCCF32201-22F	BEARING	1	34C	PDCCF32201-34C	RIVET NUT 1/4"	8
22G	PDCCF32201-22G	SEAL	1	34D	PDCCF32201-34D	RIVET NUT 5/16"	18
23	PDCCF32201-23V2	ROTATION SHAFT V2.2021	1	35	PDCCF32201-35	ROUND HD BOLT 3/16" x 1/2"	24
23A	PDCCF32201-23A	HEX BOLT 1/4" x 5/8"	8	35A	PDCCF32201-35A	NUT 3/16"	24
23B	PDCCF32201-23B	FLAT WASHER 1/4" x 13 x 1mm	16	36	PDCCF32201-36V2	FREQUENCY REMOTE SWITCH V2.2021	1
23C	PDCCF32201-23C	PADDLE	2	44	PDCCF32201-44	RUBBER PLUG 30mm x 60mm	4
23D	PDCCF32201-23D	PADDLE BRANCH	4	47	PDCCF32201-47	CROSSBAR	1
23E	PDCCF32201-23E	HEX LOCK NUT 1/4"	8	48	PDCCF32201-48	SILICONE	1
23F	PDCCF32201-23F	ROTATION SHAFT CONNECTION	1				
23G	PDCCF32201-23G	HEX BOLT 5/16" x 1-1/2"	1				



SPECIFICATIONS: CFLUX2

Motor Specs:	2 HP
Electrical Specs:	220V / 60Hz / 1PH / 3450 RPM
Running AMP	(6" inlet) 14A at 220V
Air Volume:	1166CFM (cubic feet per minute)
Max. static pressure	9.3 Inches of water
Fan size	14.5"
Inlet:	8" port or (2) 4" ports
Switch	High frequency remote control switch
Collection capacity	46-gallon Octagon drum
Packing Size: (L x W x H)	49.6" x 30.3" x 49.2" (126 x 77 x 125 cm)
Machine weight	301 lbs. (140 kgs)
Shipping weight	377 lbs. (171 kgs)

<u>Filter Media</u>	filtering area: 102 sq/ft (9.5 m2)
Cartridge Filter	1 Micron 15.74" x 35.43" (40 x 90cm) x 1pc

SUPPLIES:

Plastic debris collection bag, 20-gallon

SKU/Part # PDCCF-FB22



SPECIFICATIONS: CFLUX3

Motor Specs:	3 HP
Electrical Specs:	220V / 60Hz / 1PH / 3450 RPM
Running AMP	(8" inlet) 22A at 220V
Air Volume:	1624CFM (cubic feet per minute)
Max. static pressure	11.2 Inches of water
Fan size	15.5"
Inlet:	8" port or (3) 4" ports
Switch	High frequency remote control switch
Collection capacity	46-gallon Octagon drum
Packing Size: (L x W x H)	49.6" x 30.3" x 49.2" (126 x 77 x 125 cm)
Machine weight	373 lbs. (169 kgs)
Shipping weight	441 lbs. (200 kgs)

<u>Filter Media</u>	filtering area: 102 sq/ft (9.5 m2)
Cartridge Filter	1 Micron 15.74" x 35.43" (40 x 90cm) x 1pc

SUPPLIES:

Plastic debris collection bag, 20-gallon

SKU/Part # PDCCF-FB22



NOTES

Ph: 800.234.1976
www.lagunatools.com

100721