



Trash Enclosure

EXTRA-LARGE SIZE (Up to 96 gallons per module)

Material and Features

Enclosure cabinet: marine-grade bent aluminum, powder-coated in dark pewter.

Siding: recycled bamboo composite boards in charcoal or coffee.

Lock hasp: aluminum, compatible with padlocks.

Hardware: stainless steel hinges, screws, latches, and leveling feet.

Sectional top doors: secured with hydraulic, slow-closing arms.

Front doors: aluminum handle opener. stainless steel latches.

Leveling feet: adjustable from 0.5-7 inches.

Warranty: 5 years.

Weight: 127 lbs. per module.

Measurements (inches)

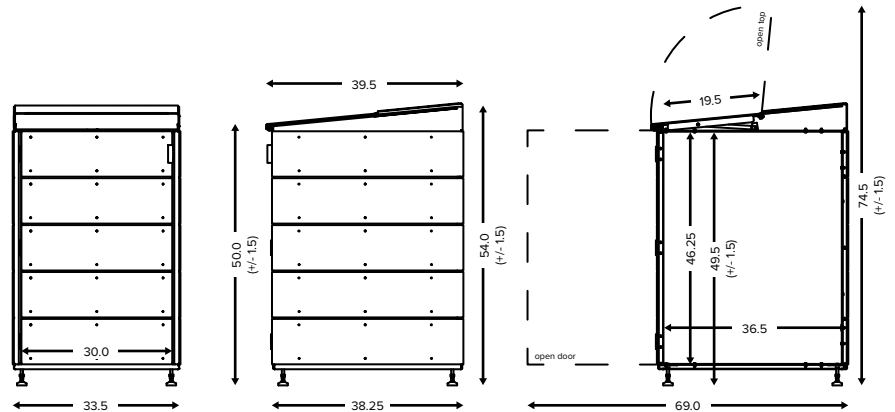

#Modules	Width	Height	Depth	Colors	Options
1-module:	33.5"				
2-module:	66.5"	Back 54"	38.25"	Coffee	• Sectional top doors
3-module:	99.5"	(+/-6.5")	69.0" with doors open)	Charcoal	
4-module:	132.5"	Front 50"			
5-module:	165.5"	(+/-6.5")			
6-module:	198.5"				

Standardized for common can sizes



2-module XL-size CITIBIN trash enclosure, cladding, with sectional top door.



Standardized to fit most 65 to 95 gallon wheeled trash carts.

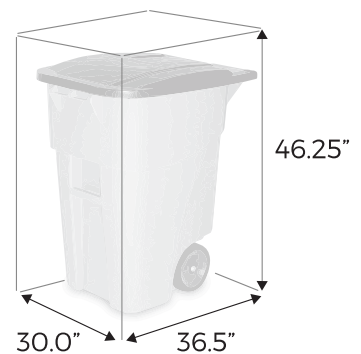

Max. interior dimension / max. trash can size.