



Installation instructions for 99-5804

APPLICATIONS

See application list inside

Ford/Lincoln/Mazda/Mercury 1995-2011 99-5804

KIT FEATURES

- DIN radio provision with pocket
- ISO radio provision with pocket



KIT COMPONENTS

- A) Radio housing "A" • B) Radio housing "B" • C) Rear support

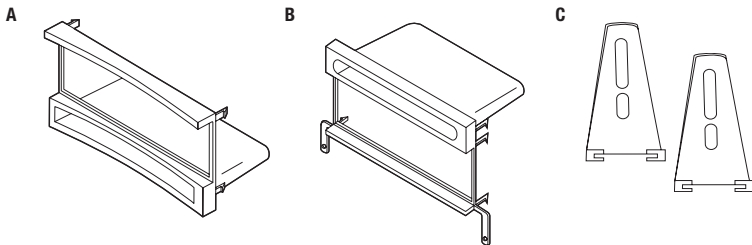

WIRING & ANTENNA CONNECTIONS (sold separately)

Wiring Harness:

- Visit www.metraonline.com for specific interface applications

Antenna Adapter:

- 40-CR10 - Chrysler antenna adapter 2002-up

TOOLS REQUIRED

- 86-5618 radio removal keys
- Phillips screwdriver • Utility knife • Wrench

CAUTION: Metra recommends disconnecting the negative battery terminal before beginning any installation. All accessories, switches, and especially air bag indicator lights must be plugged in before reconnecting the battery or cycling the ignition.

NOTE: Refer to the instructions included with the aftermarket radio.

Applications

Ford

Crown Victoria	1995-2011
Econoline	1997-2008
Escape	2001-2007
Excursion	2000-2005
Expedition	1997-2002
Explorer	1995-2001
Explorer Sport Trac	2001-2005
F-150	1997-2003
F-150 Heritage	2004
F-250	1998-2004
F-350	1999-2004
F-450	1999-2004
F-550	1999-2004
F-650	2000-2010
F-750	2000-2010
Ranger	1995-2011
Windstar	1999-2003

Lincoln

Blackwood	2002
Continental	1995-1997
Mark 8	1995-1998
Navigator	1997-2002
Town Car	1995-2002

Mazda

B-Series Pickup	1995-2009
-----------------------	-----------

Mercury

Cougar (<i>with 6 disc in-dash</i>).....	2000-2002
Grand Marquis	1995-2011
Marauder	2003-2004
Mariner	2005-2007
Mountaineer	1997-2001

Table of Contents

Dash Disassembly

– Ford Crown Victoria 1995-2011/Econoline 1997-2008/ Escape 2001-2007/Explorer 1995-2001/Explorer Sport Trac 2001-2005/ F-250, F-350, F-450, F-550 1999-2004/F-650, F-750 2000-2010/ Ranger 1995-2011/Windstar 1999-2003	3
– Lincoln Continental 1995-1997/Mark 8 1995-1998/ Town Car 1995-2002	3
– Mazda B-Series pickup 1995-2009	3
– Mercury Cougar (<i>with 6 disc in-dash</i>) 2000-2002/ Grand Marquis 1995-2011/Mountaineer 1997-2001/ Mariner 2005-2007/Marauder 2003-2004	3
– Ford F150 1997-2003/ F-150 Heritage 2004/ F-250 1998/ Expedition 1997-2002/Excursion 2000-2005	4-5
– Lincoln Blackwood 2002/Navigator 1997-2002	4-5

Table of Contents

Kit Assembly

- **Ford** Econoline 1997-2008/Escape 2001-2007/Explorer 1995-2001/
Explorer Sport Trac 2001-2005/F-250, F-350, F-450, F-550 1999-2004/
Ranger 1995-2011/Windstar 1999-2003, **Lincoln**
Continental 1995-1997/Mazda B-Series 1995-2009, **Mercury**
Moutaineer 1997-2001/Mariner 2005-2007 4-5
- **Ford** Crown Victoria 1995-2011/F-650, F-750 2000-2010, **Mercury**
Cougar (with 6 disc in-dash) 2000-2002/Grand Marquis 1995-2011
Marauder 2003-2004/Town Car 1995-2002/
Lincoln Continental 1995-1997/Mark 8 1995-19985
- **Ford** Expedition 1997-2002/F-150 1997-2003/F-150 Heritage 2004/
F-250 1998/Excursion 2000-2005, **Lincoln** Blackwood 2002/
Navigator 1997-2002.....6

Ford Crown Victoria 1995-2011/Econoline 1997-2008/Escape 2001-2007/Explorer 1995-2001/
Explorer Sport Trac 2001-2005/F-250, F-350, F-450, F-550 1999-2004/F-650, F-750 200-2010/
Ranger 1995-2011/Windstar 1999-2003, **Lincoln**
Continental 1995-1997/Mark 8 1995-1998/Town
Car 1995-2002, **Mazda** B-Series pickup 1995-
2009, **Mercury** Cougar (with 6 disc in-dash) 2000-2002/
Grand Marquis 1995-2011/Mountaineer 1997-
2001/Mariner 2005-2007/Marauder 2003-2004

1. Using Metra's 86-5618, pull the factory radio from the dash and disconnect the wiring. (Figure A)
2. Locate radio housing "A". (Figure B)

Continue to kit assembly, p. 4 or 5

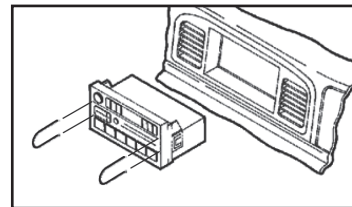

(Figure A)

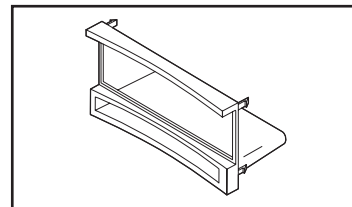

(Figure B)

**Ford F150 1997-2003/F-150 Heritage 2004/
F-250 1998/Expedition 1997-2002/Excursion
2000-2005, Lincoln Blackwood 2002/
Navigator 1997-2002**

1. Place your index fingers on the inner edges of the A/C vents and push inward. (Figure A)
2. Grasp the exposed lip of each vent opening and pull out on the radio trim bezel. (Figure A)
3. Remove the dash trim bezel (airbag wiring does **NOT** need to be disconnected). (Figure A)
4. Using Metra's 86-5618, pull the factory radio from the dash and disconnect the wiring.
5. Locate radio housing "B". (Figure B)

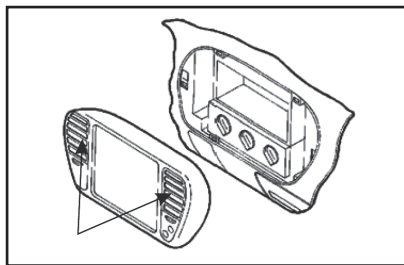

(Figure A)

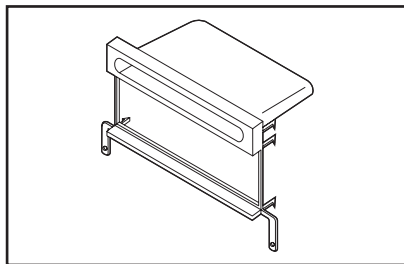

(Figure B)

Continue to kit assembly, p. 6

**Ford Econoline 1997-2008/Escape 2001-2007/
Explorer 1995-2001/Explorer Sport Trac
2001-2005/F-250/F-350/F-450/F-550 1999-2004/
Ranger 1995-2011/Windstar 1999-2003, Lincoln
Continental 1995-1997/Mazda B-Series
1995-2009, Mercury Mountaineer 1997-2001/
Mariner 2005-2007**

1. Slide the DIN cage into the radio housing and secure by bending the metal locking tabs down. Then, slide the aftermarket radio into the cage until secure. (Figure A)
2. Mount the rear support to the back of the radio using the hardware included with the radio. (Figure A)
3. Locate the factory wiring harness

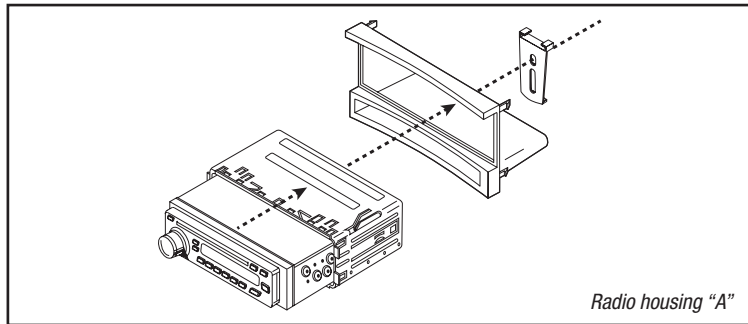

(Figure A)

Radio housing "A"



Kit Assembly 99-5804

**Ford Econoline 1997-2008/Escape 2001-2007/
Explorer 1995-2001/Explorer Sport Trac
2001-2005/F-250/F-350/F-450/F-550 1999-2004/
Ranger 1995-2011/Windstar 1999-2003, Lincoln
Continental 1995-1997/Mazda B-Series
1995-2009, Mercury Mountaineer 1997-2001/
Mariner 2005-2007**

in the dash. Metra recommends using the proper mating adapter from Metra or AXXESS. Re-connect the negative battery terminal and test the unit for proper operation.

4. Snap the radio kit assembly into the sub-dash. (Figure B)

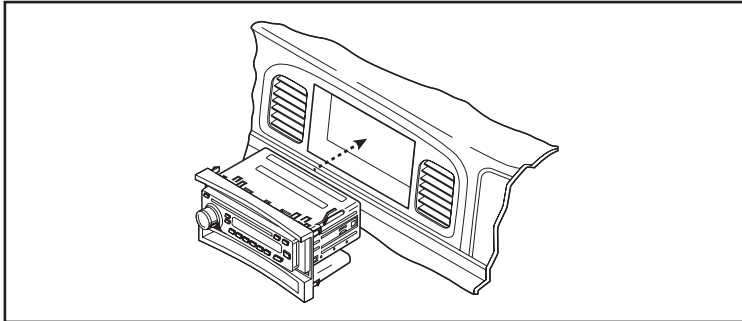

(Figure B)

**Ford Crown Victoria 1995-2011/F-650,
F-750 2000-2010, Mercury Cougar (with 6 disc in-dash)
2000-2002/Grand Marquis 1995-2011/Marauder
2003-2004/Town Car 1995-2002,
Lincoln Mark 8 1995-1998**

1. Slide the DIN cage into the radio housing and secure by bending the metal locking tabs down. Then slide the radio into the cage until secure. (Figure A)
2. Locate the factory wiring harness in the dash. Metra recommends using the proper mating adapter

from Metra or AXXESS. Re-connect the negative battery terminal and test the unit for proper operation.

3. Snap the radio/kit assembly into the sub-dash. (Figure A)

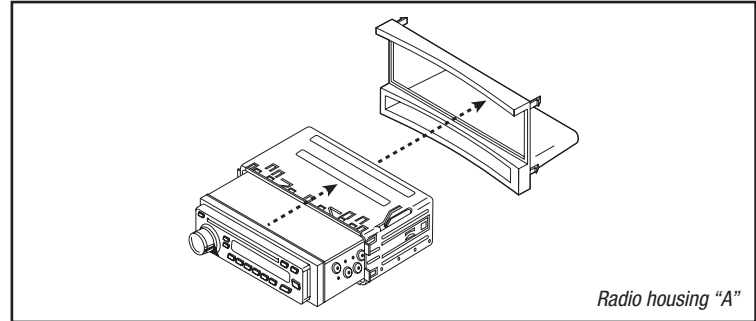

(Figure A)



Kit Assembly 99-5804

Ford Expedition 1997-2002/F-150 1997-2003/F-150 Heritage 2004/ F-250 1998/Excursion 2000-2005, Lincoln Blackwood 2002/Navigator 1997-2002

1. Remove the top (2) Phillips screws securing the climate control cluster to the sub-dash.

Note, for the Ford Expedition 1997-1998, F-150 1997-1998, F-250 1998 remove the rear support bracket from the dash cavity using one of the following methods:

(a) Remove (1) 7mm hex-head bolt securing the bottom of the bracket to the back wall of the sub-dash and (2) 7mm hex-head bolts securing

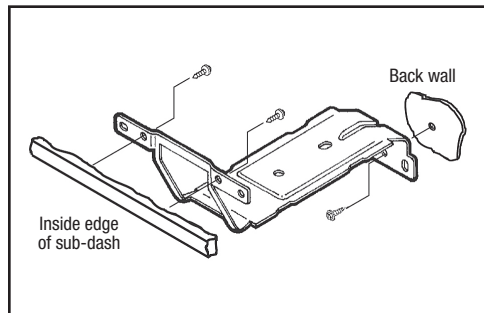

(Figure A)

the top of the bracket to the inside edge of the sub-dash. Remove bracket. (Figure A)

(b) Remove (1) hex-head bolt securing the bottom of the bracket to the back wall of the sub-dash and cut the bracket flush with the top edge of the radio opening. Remove the bracket. (Figure B)

2. Slide the radio/kit assembly into the dash cavity and mount the bottom legs of the kit to the same holes in the climate control cluster with the (2) Phillips screws previously removed. (Figure C)

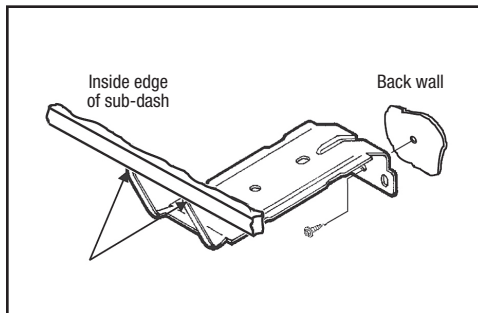

(Figure B)

3. Locate the factory wiring harness in the dash. Metra recommends using the proper mating adapter from Metra or AXXESS. Re-connect the negative battery terminal and test the unit for proper operation.
4. Reassemble dash in reverse order of disassembly.

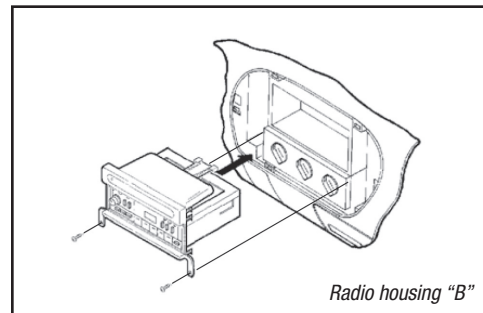

(Figure C)



Installation instructions for 99-5804



REV. 3/25/2015 INST99-5804



KNOWLEDGE IS POWER

Enhance your installation and fabrication skills by enrolling in the most recognized and respected mobile electronics school in our industry. Log onto www.installerinstitute.com or call 800-354-6782 for more information and take steps toward a better tomorrow.



**Metra recommends MECP
certified technicians**



Instrucciones de instalación para 99-5804

APLICACIONES

Lista de aplicaciones dentro

Ford/Lincoln/Mazda/Mercury 1995-2011 99-5804

CARACTERÍSTICAS DEL KIT

- Provisión de radio DIN con bolsillo
- Provisión de radio ISO con bolsillo



COMPONENTES DEL KIT

- A) Carcasa del radio "A" • B) Carcasa del radio "B" • C) Soporte trasero

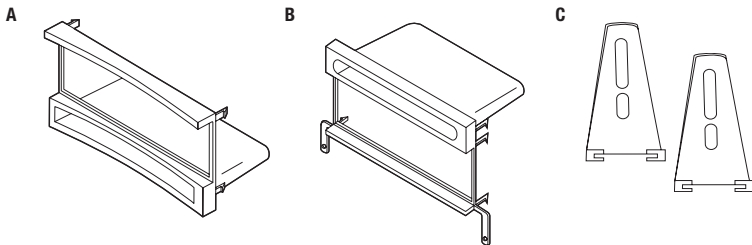

CABLEADO Y CONEXIONES DE ANTENA

Arnés de cableado: (se venden por separado)

- Visite www.metraonline.com para ver aplicaciones específicas de interfase

Adaptador de antena:

- 40-CR10 - Cable adaptador de antena Chrysler 2002

HERRAMIENTAS REQUERIDAS

- Llaves de remoción de unidad central 86-5618
- Destornillador Phillips • Navaja • Llave mecánica

PRECAUCIÓN: Metra recomienda desconectar el terminal negativo de la batería antes de comenzar cualquier instalación. Todos los accesorios, interruptores y, especialmente, las luces indicadoras de airbag deben estar enchufados antes de volver a conectar la batería a comenzar el ciclo de ignición.

NOTA: Remítase a las instrucciones incluidas con el radio de postventa.

Aplicaciones

Ford

Crown Victoria	1995-2011
Econoline	1997-2008
Escape	2001-2007
Excursion	2000-2005
Expedition	1997-2002
Explorer	1995-2001
Explorer Sport Trac	2001-2005
F-150	1997-2003
F-150 Heritage	2004
F-250	1998-2004
F-350	1999-2004
F-450	1999-2004
F-550	1999-2004
F-650	2000-2010
F-750	2000-2010
Ranger	1995-2011
Windstar	1999-2003

Lincoln

Blackwood	2002
Continental	1995-1997
Mark 8	1995-1998
Navigator	1997-2002
Town Car	1995-2002

Mazda

B-Series Pickup	1995-2009
-----------------------	-----------

Mercury

Cougar (<i>con 6 discos en el tablero</i>).....	2000-2002
Grand Marquis	1995-2011
Marauder	2003-2004
Mariner	2005-2007
Mountaineer	1997-2001

Indice

Desmontaje del tablero

- **Ford** Crown Victoria 1995-2011/Econoline 1997-2008/
Escape 2001-2007/Explorer 1995-2001/Explorer Sport Trac 2001-2005/
F-250, F-350, F-450, F-550 1999-2004/F-650, F-750 2000-2010/
Ranger 1995-2011/Windstar 1999-2003 3
- **Lincoln** Continental 1995-1997/Mark 8 1995-1998/
Town Car 1995-2002 3
- **Mazda** B-Series pickup 1995-2009 3
- **Mercury** Cougar (*con 6 discos en el tablero*) 2000-2002/
Grand Marquis 1995-2011/Mountaineer 1997-2001/
Mariner 2005-2007/Marauder 2003-2004 3
- **Ford** F150 1997-2003/ F-150 Heritage 2004/ F-250 1998/
Expedition 1997-2002/Excursion 2000-2005 4-5
- **Lincoln** Blackwood 2002/Navigator 1997-2002 4-5

Indice

Ensamble del kit

- **Ford** Econoline 1997-2008/Escape 2001-2007/Explorer 1995-2001/
Explorer Sport Trac 2001-2005/F-250, F-350, F-450, F-550 1999-2004/
Ranger 1995-2011/Windstar 1999-2003, **Lincoln**
Continental 1995-1997/Mazda B-Series 1995-2009, **Mercury**
Mountaineer 1997-2001/Mariner 2005-2007 4-5
- **Ford** Crown Victoria 1995-2011/F-650, F-750 2000-2010, **Mercury**
Cougar (*con 6 discos en el tablero*) 2000-2002/Grand Marquis 1995-2011
Marauder 2003-2004/Town Car 1995-2002/
Lincoln Continental 1995-1997/Mark 8 1995-19985
- **Ford** Expedition 1997-2002/F-150 1997-2003/F-150 Heritage 2004/
F-250 1998/Excursion 2000-2005, **Lincoln** Blackwood 2002/
Navigator 1997-2002.....6

Ford Crown Victoria 1995-2011/Econoline 1997-2008/Escape 2001-2007/Explorer 1995-2001/Explorer Sport Trac 2001-2005/F-250, F-350, F-450, F-550 1999-2004/F-650, F-750 2000-2010/Ranger 1995-2011/Windstar 1999-2003, Lincoln Continental 1995-1997/Mark 8 1995-1998/Town Car 1995-2002, Mazda B-Series pickup 1995-2009, Mercury Cougar (*con 6 discos en el tablero*) 2000-2002/Grand Marquis 1995-2011/Mountaineer 1997-2001/Mariner 2005-2007/Marauder 2003-2004

1. Usando las llaves 86-5618 de Metra, jale el radio de fábrica del tablero y desconecte el cableado. (Figura A)
2. Localice la carcasa "A" del radio. (Figura B)

Continúe con el ensamble del kit, página 4 o 5

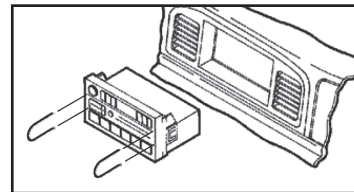

(Figura A)

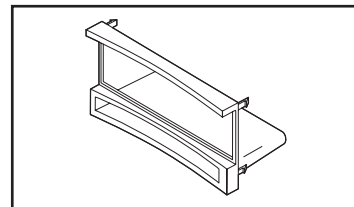

(Figura B)

**Ford F150 1997-2003/F-150 Heritage 2004/
F-250 1998/Expedition 1997-2002/Excursion
2000-2005, Lincoln Blackwood 2002/
Navigator 1997-2002**

1. Coloque sus dedos índices en los bordes internos de las rejillas del aire acondicionado y jale hacia adentro. (Figura A)
2. Sujete el borde expuesto de cada apertura de rejilla y jale hacia afuera el bisel de la moldura del radio. (Figura A)
3. Quite el bisel de la moldura del tablero (**NO es necesario** desconectar el cableado de la bolsa de aire). (Figura A)
4. Usando las llaves 86-5618 de Metra, jale el radio de fábrica del tablero y desconecte el cableado.
5. Localice la carcasa "B" del radio. (Figura B)

Continúe con el ensamble del kit, página 4 o 5. 6

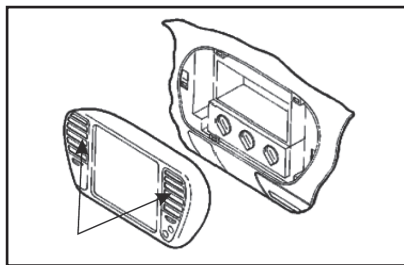

(Figura A)

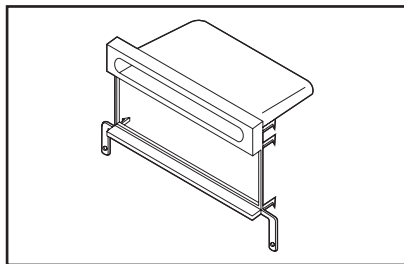

(Figura B)

**Ford Econoline 1997-2008/Escape 2001-2007/
Explorer 1995-2001/Explorer Sport Trac
2001-2005/F-250/F-350/F-450/F-550 1999-2004/
Ranger 1995-2011/Windstar 1999-2003, Lincoln
Continental 1995-1997/Mazda B-Series
1995-2009, Mercury Mountaineer 1997-2001/
Mariner 2005-2007**

1. Deslice la reja DIN en la carcasa del radio y sujétela doblando hacia abajo las pestañas de metal. Deslice el radio de mercado secundario en la reja hasta que quede firme. (Figura A)
2. Monte el soporte trasero en la parte posterior del radio con la tornillería incluida con el mismo. (Figura A)
3. Ubique el arnés de cableado

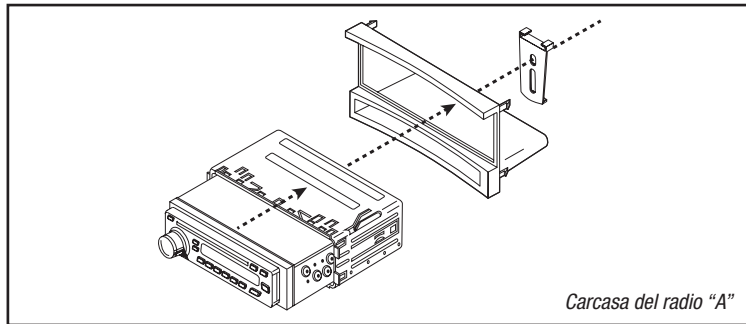

Carcasa del radio "A"

(Figura A)

**Ford Econoline 1997-2008/Escape 2001-2007/
Explorer 1995-2001/Explorer Sport Trac
2001-2005/F-250/F-350/F-450/F-550 1999-2004/
Ranger 1995-2011/Windstar 1999-2003, Lincoln
Continental 1995-1997/Mazda B-Series
1995-2009, Mercury Mountaineer 1997-2001/
Mariner 2005-2007**

de fábrica en el tablero. Metra recomienda el uso de un adaptador adecuado de acoplamiento de Metra o de AXXESS. Vuelva a conectar la terminal negativa de la batería y pruebe la unidad

para verificar que funcione correctamente.

4. Coloque a presión el ensamble del kit del radio en el sub tablero. (Figura B)

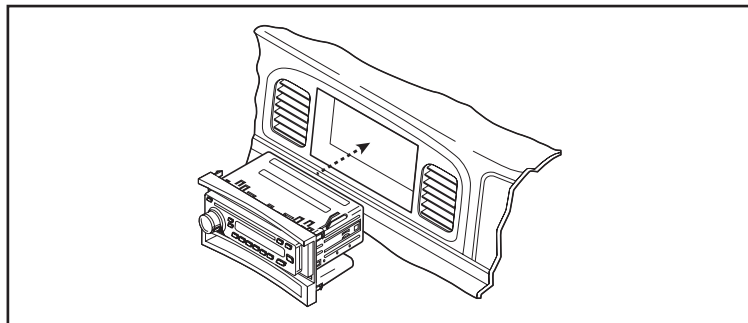

(Figura B)

**Ford Crown Victoria 1995-2011/F-650,
F-750 2000-2010, Mercury Cougar (con 6 discos en
el tablero) 2000-2002/Grand Marquis 1995-2011/
Marauder 2003-2004/Town Car 1995-2002,
Lincoln Mark 8 1995-1998**

1. Deslice la reja DIN en la carcasa del radio y sujétela doblando hacia abajo las pestañas de metal. Luego, deslice el radio de mercado secundario en la reja hasta que quede firme. (Figura A)
2. Ubique el arnés de cableado de fábrica en el tablero. Metra

recomienda el uso de un adaptador adecuado de acoplamiento de Metra o de AXXESS. Vuelva a conectar la terminal negativa de la batería y pruebe la unidad para verificar que funcione correctamente.

3. Coloque a presión el radio/ensamble del kit en el sub tablero. (Figura A)

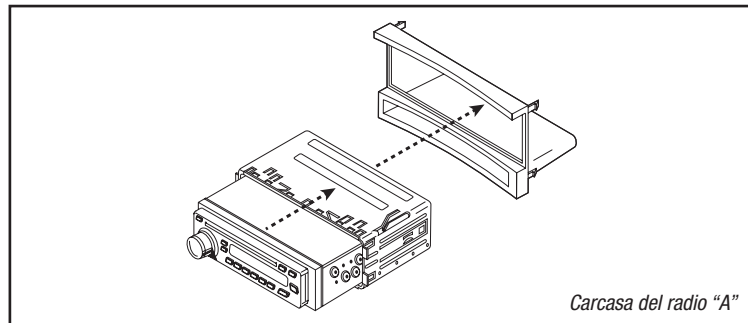

Carcasa del radio "A"

(Figura A)

**Ford Expedition 1997-2002/F-150 1997-2003/F-150 Heritage 2004/
F-250 1998/Excursion 2000-2005, Lincoln Blackwood 2002/Navigator 1997-2002**

1. Quite los (2) tornillos Phillips superiores que sujetan el conjunto de control de clima al sub tablero.

Nota, para Ford Expedition 1997-1998, F-150 1997-1998, F-250 1998 quite el soporte trasero de la cavidad del tablero siguiendo uno de estos métodos:

(a) Quite (1) perno de cabeza hexagonal de 7mm que sujeta la parte inferior del soporte a la pared trasera del sub tablero y (2) pernos de cabeza hexagonal de 7mm que sujetan la parte superior

del soporte al borde interior del sub tablero. Quite el soporte. (Figura A)

(b) Quite (1) perno de cabeza hexagonal que sujeta la parte inferior del soporte a la pared trasera del sub tablero y corte el soporte al ras del borde superior de la apertura del radio. Quite el soporte. (Figura B)

2. Deslice el radio/ensamble del kit en la cavidad del tablero y monte las patas inferiores del kit en los mismos orificios que el conjunto del control

de clima con los (2) tornillos Phillips previamente retirados. (Figura C)

3. Ubique el arnés de cableado de fábrica en el tablero. Metra recomienda el uso de un adaptador adecuado de acoplamiento de Metra o de AXXESS. Vuelva a conectar la terminal negativa de la batería y pruebe la unidad para verificar que funcione correctamente.
4. Vuelva a armar el tablero al revés de como lo desarmó.

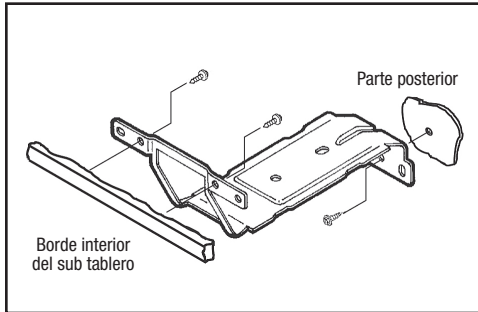

(Figura A)

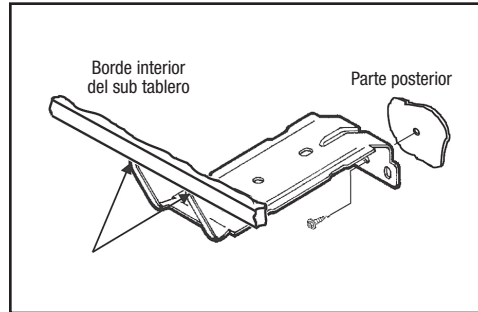

(Figura B)

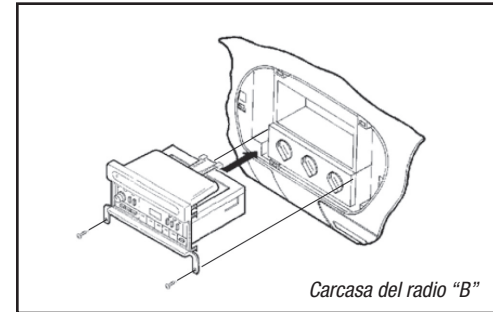

(Figura C)



Notas

Blank lined area for taking notes, consisting of 13 horizontal lines on a white background.



Instrucciones de instalación para 99-5804



REV. 3/25/2015 INST99-5804



EL CONOCIMIENTO ES PODER

Mejore sus habilidades de instalación y fabricación inscribiéndose en la escuela de dispositivos electrónicos móviles más reconocida y respetada de nuestra industria. Regístrese en www.installerinstitute.com o llame al 800-354-6782 para obtener más información y avance hacia un futuro mejor.



Metra recomienda técnicos con certificación del Programa de Certificación en Electrónica Móvil (Mobile Electronics Certification Program, MECP).