



## Installation instructions for 99-5510

### APPLICATIONS

See application list inside

# Ford/Jeep/Lincoln/Mercury 1975-2000 99-5510

### KIT FEATURES

- DIN radio provision

### KIT COMPONENTS

- A) Radio housing • B) Rounded faceplate • C) Cornered faceplate • D) Rear support • E) Bracket set #1
- F) Bracket set #2 • G) Spacer set #1 • H) Spacer set #2 • I) (4) #8 x 1" Phillips screws

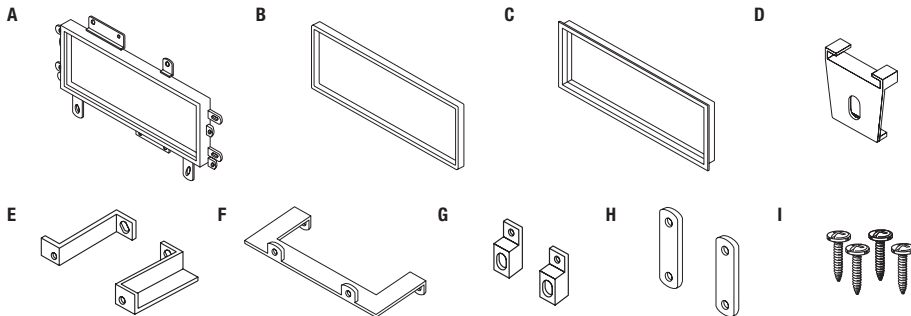

REV 10/9/2014 INST99-5510

### WIRING & ANTENNA CONNECTIONS (sold separately)

Wiring Harness:

- 70-1002
- 70-1770
- 70-1772
- 70-1781

Antenna Adapter:

- Not required

### TOOLS REQUIRED

- Phillips screwdriver • Cutting tool
- 86-5618 Radio removal keys

**CAUTION:** Metra recommends disconnecting the negative battery terminal before beginning any installation. All accessories, switches, and especially air bag indicator lights must be plugged in before reconnecting the battery or cycling the ignition.

**NOTE:** Refer to the instructions included with the aftermarket radio.



99-5510

## Applications

### AMC

Alliance.....	1983-1987
Encore.....	1983-1987
GTA.....	1983-1987

### Ford

Aerostar.....	1992-1997
Aerostar.....	1985-1991
Aspire.....	1995-1997
Bronco.....	1992-1996
Bronco (full size).....	1987-1991
Bronco II.....	1983-1988
Contour.....	1995-2000
Crown Victoria.....	1992-1994
Econoline.....	1975-1991
Escort.....	1991-1996
Escort.....	1985-1990
F-Series Pickup.....	1992-1996
F-Series Pickup.....	1987-1991
Festiva.....	1988-1993
LTD.....	1979-1986
LTD Crown Victoria.....	1979-1991
Mustang.....	1994-2000
Ranger.....	1985-1988

### Ford (continued)

Taurus.....	1990-1995
Taurus.....	1986-1989
Tempo.....	1989-1994
Thunderbird.....	1989-1997
Thunderbird.....	1983-1988
Windstar.....	1995-1998

### Jeep

Cherokee.....	1984-1995
Cherokee.....	1996
Comanche.....	1986-1992
Grand Wagoneer.....	1987-1995
Wagoneer.....	1984-1996
Wrangler.....	1984-1996

### Lincoln

Continental.....	1988-1994
Continental.....	1985-1987
Mark VII.....	1990-1992
Mark VII.....	1984-1989
Mark VIII.....	1993-1995
Town Car.....	1990-1994
Town Car.....	1985-1989

### Mercury

Capri XR2.....	1991-1994
Cougar.....	1989-1997
Cougar.....	1983-1988
Grand Marquis.....	1979-1994
Lynx.....	1985-1987
Mystique.....	1995-2000
Marquis.....	1979-1986
Sable.....	1990-1995
Sable.....	1986-1989
Topaz.....	1989-1994
Tracer.....	1991-1996
Tracer (hatchback).....	1988-1990

## Table of Contents

### Dash Disassembly

– AMC Alliance/Encore/GTA 1983-1987 .....	4	– Ford Tempo/Mercury Topaz 1989-1994 .....	11
– Ford Aerostar 1985-1991 .....	4	– Ford Thunderbird/Mercury Cougar 1989-1997 .....	12
– Ford Aspire 1995-1997 .....	5	– Ford Thunderbird/Mercury Cougar 1985-1988 .....	12
– Ford Bronco ( <i>full size</i> )/F-Series Pickup 1987-1991 .....	5	– Ford Windstar 1995-1998 .....	13
– Ford Bronco II/Ranger 1985-1988 .....	6	– Jeep Cherokee 1984-1995/Commanche 1986-1992/ Wagoneer 1984-1996 .....	13
– Ford Contour/Mercury Mystique 1995-2000 .....	6	– Jeep Cherokee 1996 .....	14
– Ford LTD/LTD Crown Victoria, Mercury Marquis/Grand Marquis 1979-1989 .....	7	– Jeep Grand Wagoneer 1987-1995 .....	14
– Ford Crown Victoria/LTD Crown Victoria, Mercury Grand Marquis 1990-1994 .....	7	– Jeep Wrangler 1986-1996 .....	15
– Ford Escort/Mercury Tracer 1991-1996 .....	8	– Lincoln Continental 1988-1994/Mark VII 1990-1992/ Town Car 1990-1994 .....	15
– Ford Escort/Mercury Lynx 1985-1990 .....	8	– Lincoln Continental 1985-1987 .....	16
– Ford F-Series Pickup/Bronco 1992-1996 .....	9	– Lincoln Mark VII 1984-1989 .....	16
– Ford Festiva 1988-1993 .....	9	– Lincoln Mark VIII 1993-1995 .....	17
– Ford Mustang 1994-2000 .....	10	– Lincoln Town Car 1984-1989 .....	17
– Ford Taurus/Mercury Sable 1990-1995 .....	10	– Mercury Capri XR2 1991-1994 .....	18
– Ford Taurus/Mercury Sable 1986-1989 .....	11	– Mercury Tracer ( <i>hatchback</i> ) 1988-1990 .....	18
		<b>Kit Assembly .....</b>	<b>19</b>

## AMC Alliance/Encore/GTA 1983-1987

1. Gently remove the climate control trim panel and (2) Phillips screws exposed.
2. Lift up on the dash trim bezel and remove. Remove (2) screws securing the factory radio and disconnect the wiring.
3. Cut and remove all mounting tabs on the radio housing EXCEPT tabs "B".

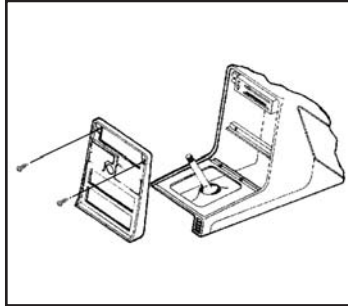

(Figure A)

**Note:** The mounting tabs can be identified by the stamped letter on the back of each tab.

4. Mount bracket set #1 to the back of the mounting tabs with (2) #8 x 1" Phillips screws supplied.

*Continue to kit assembly*

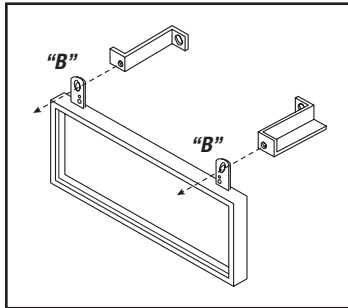

(Figure B)

## Ford Aerostar 1985-1991

1. Remove (2) Phillips screws from the base of the dash trim bezel. Pry down on the (2) tabs located at the top of the dash trim bezel and remove the bezel. (Figure A)
2. Remove (4) screws securing the factory radio and disconnect the wiring.
3. Cut and remove all mounting tabs on the radio housing EXCEPT tabs "D" and "F". (Figure B)

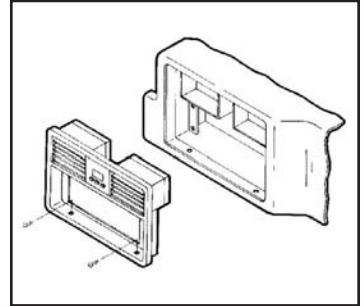

(Figure A)

**Note:** The mounting tabs can be identified by the stamped letter on the back of each tab.

4. Locate spacer set #2 (the spacers must be placed behind the mounting tabs during installation). (Figure B)

*Continue to kit assembly*

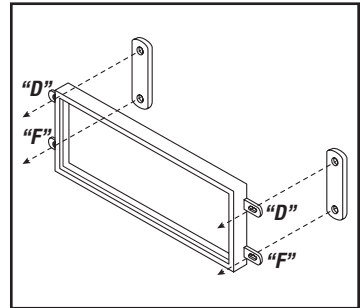

(Figure B)

## Ford Aspire 1995-1997

1. Using Metra's 86-5618, pull the factory radio from the dash and disconnect the wiring. (Figure A)
2. Locate the rounded and cornered faceplates. (Figure B)

*Continue to kit assembly*

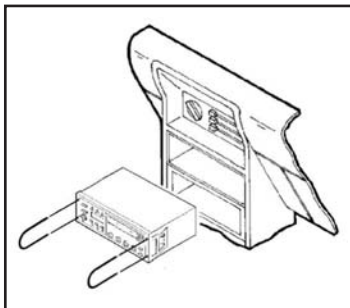

(Figure A)

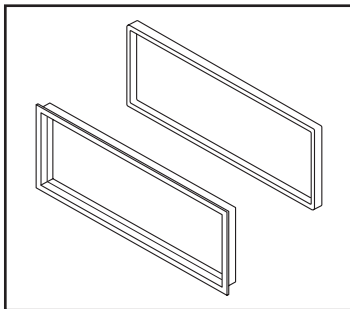

(Figure B)

## Ford Bronco (full size)/F-Series Pickup 1987-1991

1. Carefully pull and remove the dash trim bezel. Remove (4) screws securing the factory radio and disconnect the wiring. (Figure A)
2. Cut and remove all mounting tabs on the radio housing EXCEPT tabs "D" and "F". (Figure B)

**Note:** The mounting tabs can be identified by the stamped letter on the back of each tab.

3. Locate spacer set #2 (the spacers must be placed behind the mounting tabs during installation). (Figure B)

*Continue to kit assembly*

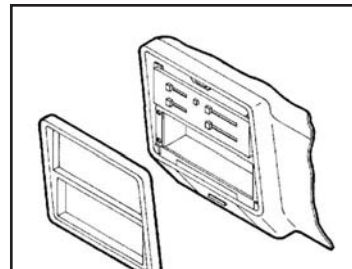

(Figure A)

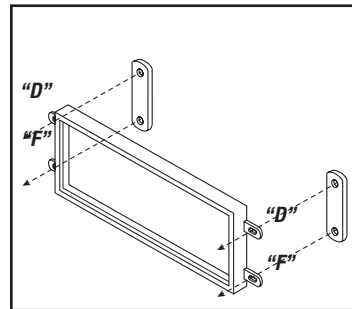

(Figure B)

## Ford Bronco II/Ranger 1985-1988

1. Remove (4) Phillips screws from the top edge of the dash trim bezel. Remove the light switch knob, cigarette lighter and ashtray. (Figure A)
2. Unsnap the molding located below the dash trim bezel and remove (4) screws exposed. (Figure A)
3. Remove (4) screws securing the factory radio and disconnect the wiring.
4. Cut and remove all mounting tabs on the radio housing EXCEPT tabs "D" and "F". (Figure B)

**Note:** The mounting tabs can be identified by the stamped letter on the back of each tab.

5. Locate spacer set #2 (the spacers must be placed behind the mounting tabs during installation). (Figure B)

*Continue to kit assembly*

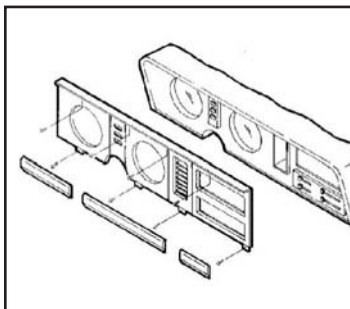

(Figure A)

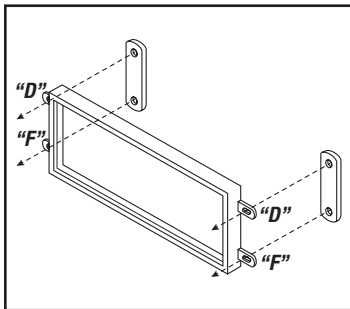

(Figure B)

## Ford Contour/Mercury Mystique 1995-2000

1. Using Metra's 86-5618, pull the factory radio from the dash and disconnect the wiring. (Figure A)
2. Locate the rounded and cornered faceplates. (Figure B)

*Continue to kit assembly*

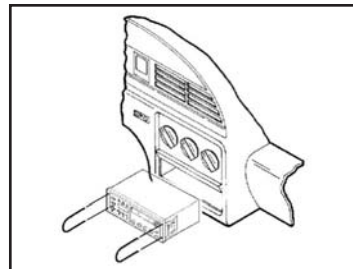

(Figure A)

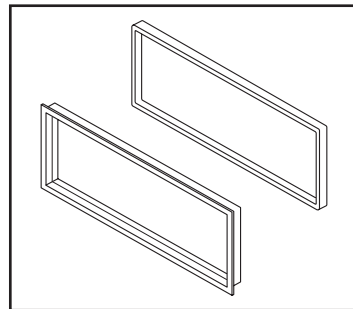

(Figure B)

## Ford LTD/LTD Crown Victoria, Mercury Marquis/Grand Marquis 1979-1989

1. Open the ashtray and remove (2) Phillips screws securing the dash trim bezel. Remove (4) screws securing the factory radio and disconnect the wiring. (Figure A)
2. Cut and remove all mounting tabs on the radio housing EXCEPT tabs "D" and "F". (Figure B)

**Note:** The mounting tabs can be identified by the stamped letter on the back of each tab.

3. Locate spacer set #2 (the spacers must be placed behind the mounting tabs during installation). (Figure B)

*Continue to kit assembly*

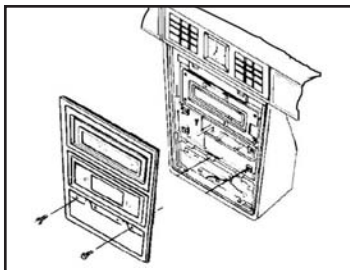

(Figure A)

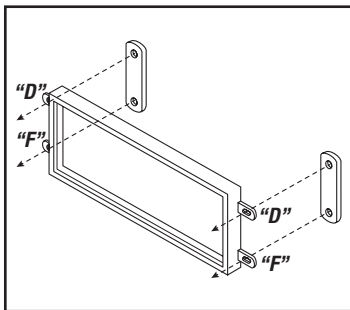

(Figure B)

## Ford Crown Victoria/LTD Crown Victoria, Mercury Grand Marquis 1990-1994

1. Using Metra's 86-5618, pull the factory radio from the dash and disconnect the wiring. (Figure A)
2. Locate the rounded and cornered faceplates. (Figure B)

*Continue to kit assembly*

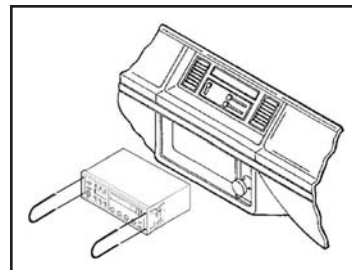

(Figure A)

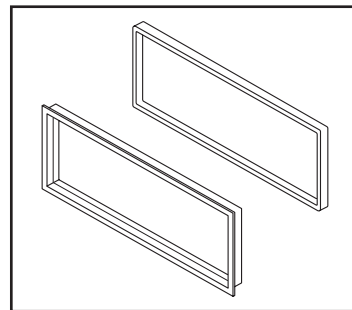

(Figure B)

## Ford Escort/Mercury Tracer 1991-1996

1. Using Metra's 86-5618, pull the factory radio from the dash and disconnect the wiring. (Figure A)
2. Locate the rounded and cornered faceplates. (Figure B)

*Continue to kit assembly*

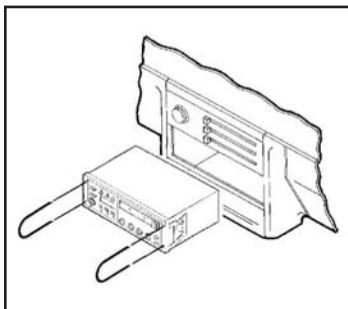

(Figure A)

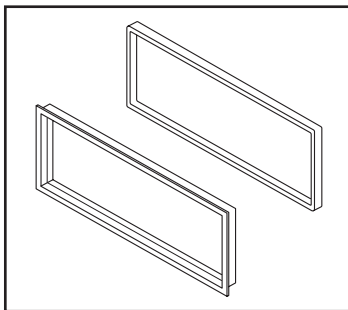

(Figure B)

## Ford Escort/Mercury Lynx 1985-1990

1. Remove (4) screws from the top edge of the dash trim bezel.
2. Remove (2) screws from the bottom edge of the dash trim bezel. Remove the climate control knobs and remove the bezel. (Figure A)
3. Remove (4) hex-head screws securing the factory radio and disconnect the wiring.
4. Cut and remove all mounting tabs on the radio housing EXCEPT tabs "B". (Figure B)

**Note:** The mounting tabs can be identified by the stamped letter on the back of each tab.

5. Mount bracket #2 to the bottom of the housing with (2) #8 x 1" Phillips Screws supplied. (Figure B)

*Continue to kit assembly*

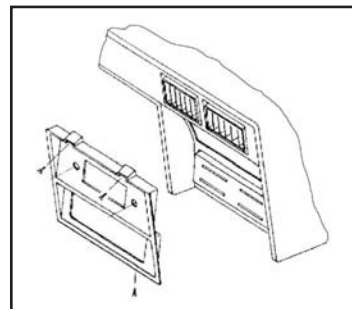

(Figure A)

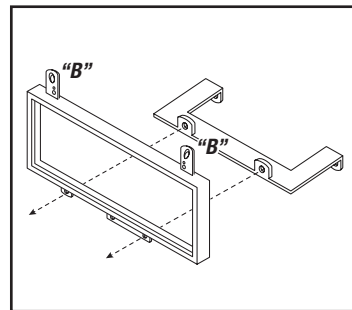

(Figure B)



## Ford F-Series Pickup/Bronco 1992-1996

1. Using Metra's 86-5618, pull the factory radio from the dash and disconnect the wiring. (Figure A)
2. Locate the rounded and cornered faceplates. (Figure B)

*Continue to kit assembly*

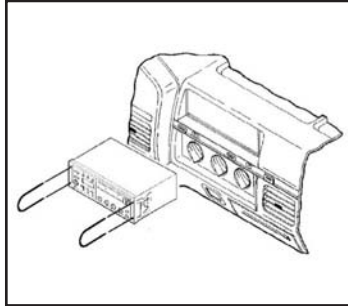

(Figure A)

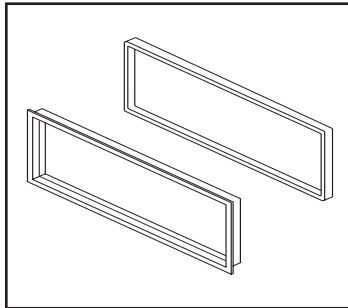

(Figure B)

## Ford Festiva 1988-1993

1. Remove (4) Phillips screws from the bottom of the dash trim bezel. Remove the bezel.
2. Remove (2) screws securing the factory radio and disconnect the wiring. (Figure A)
3. Cut and remove all mounting tabs on the radio housing EXCEPT tabs "E". (Figure B)

**Note:** The mounting tabs can be identified by the stamped letter on the back of each tab.

4. Locate spacer set #1 (the spacers must be placed behind the mounting tabs during installation). (Figure B)

*Continue to kit assembly*

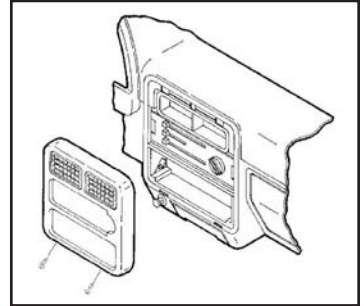

(Figure A)

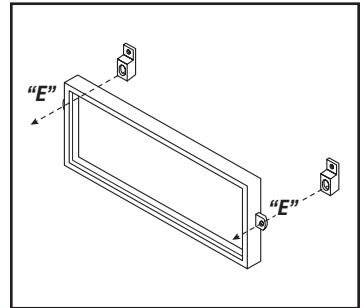

(Figure B)

## Ford Mustang 1994-2000

1. Using Metra's 86-5618, pull the factory radio from the dash and disconnect the wiring. (Figure A)
2. Locate the rounded and cornered faceplates. (Figure B)

*Continue to kit assembly*

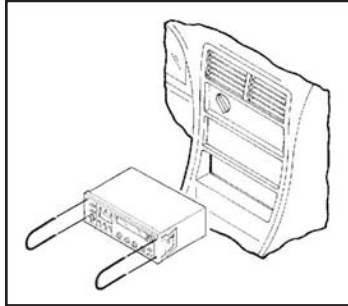

(Figure A)

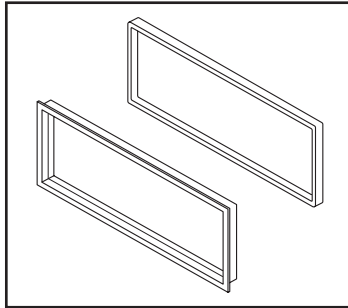

(Figure B)

## Ford Taurus/Mercury Sable 1990-1995

1. Using Metra's 86-5618, pull the factory radio from the dash and disconnect the wiring. (Figure A)
2. Locate the rounded and cornered faceplates. (Figure B)

*Continue to kit assembly*

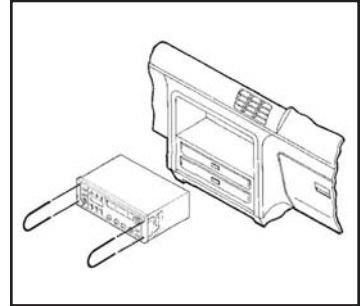

(Figure A)

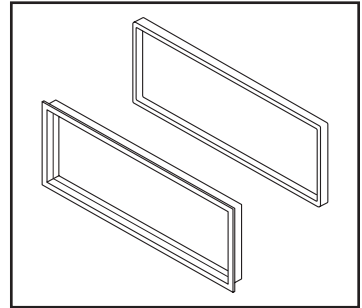

(Figure B)

## Ford Taurus/Mercury Sable 1986-1989

1. Remove (1) 7mm hex-head screw from the bottom of the radio trim bezel. Gently unclip the bezel and disconnect the antenna switch power lead. (Figure A)
2. Remove (4) screws securing the factory radio and disconnect the wiring.
3. Cut and remove all mounting tabs on the radio housing EXCEPT tabs "A". (Figure B)

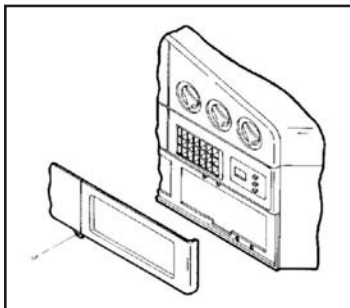

(Figure A)

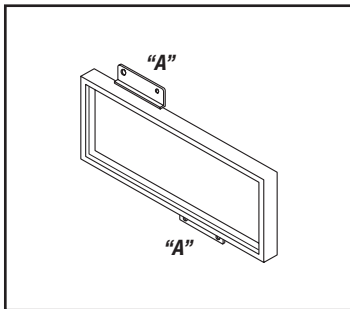

(Figure B)

**Note:** The mounting tabs can be identified by the stamped letter on the back of each tab.

*Continue to kit assembly*

## Ford Tempo/Mercury Topaz 1989-1994

1. Using Metra's 86-5618, pull the factory radio from the dash and disconnect the wiring. (Figure A)
2. Locate the rounded and cornered faceplates. (Figure B)

*Continue to kit assembly*

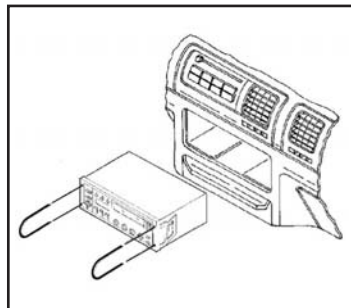

(Figure A)

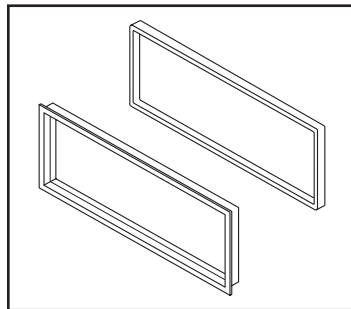

(Figure B)

## Ford Thunderbird/Mercury Cougar 1989-1997

1. Using Metra's 86-5618, pull the factory radio from the dash and disconnect the wiring. (Figure A)
2. Locate the rounded and cornered faceplates. (Figure B)

*Continue to kit assembly*

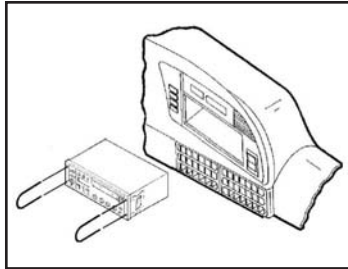

(Figure A)

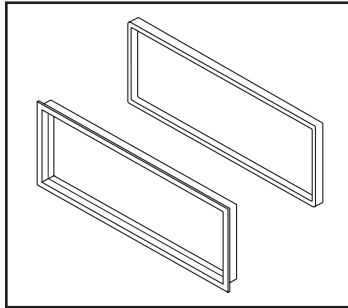

(Figure B)

## Ford Thunderbird/Mercury Cougar 1985-1988

1. Remove (2) screws from the top of the dash trim bezel.
2. Open the ashtray and remove (2) screws from the ashtray cavity.
3. Remove (4) screws securing the factory radio and bezel. (Figure A)
4. Cut and remove all mounting tabs on the radio housing EXCEPT tabs "D" and "F".

**Note:** The mounting tabs can be identified by the stamped letter on the back of each tab.

5. Locate spacer set #2 (the spacers must be placed behind the mounting tabs during installation). (Figure B)

*Continue to kit assembly*

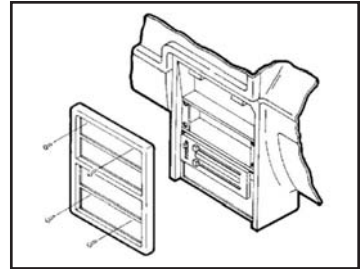

(Figure A)

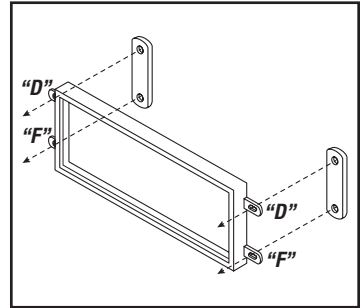

(Figure B)

## Ford Windstar 1995-1998

1. Using Metra's 86-5618, pull the factory radio from the dash and disconnect the wiring. (Figure A)
2. Locate the rounded and cornered faceplates. (Figure B)

*Continue to kit assembly*

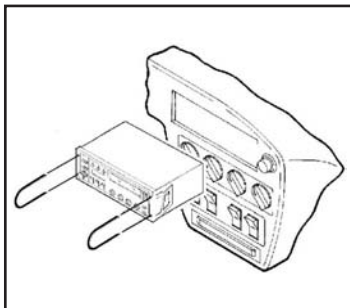

(Figure A)

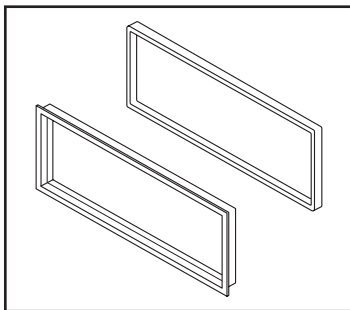

(Figure B)

## Jeep Cherokee 1984-1995/Comanche 1986-1992/Wagoneer 1984-1996

1. Unsnap the steering column trim panel and remove.
2. Remove (4) screws from the dash trim bezel and remove the bezel.
3. Remove (2) screws securing the factory radio and disconnect the wiring. (Figure A)
4. Cut and remove all mounting tabs on the radio housing EXCEPT tabs "E". (Figure B)

**Note:** The mounting tabs can be identified by the stamped letter on the back of each tab.

*Continue to kit assembly*

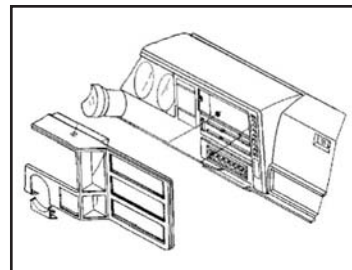

(Figure A)

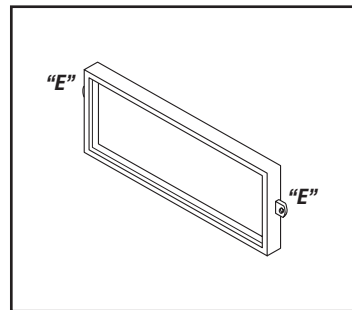

(Figure B)

## Jeep Cherokee 1996

1. Remove (3) torx-head screws from the steering column trim panels. Unscrew the tilt steering lever and unsnap the trim panels.
2. Remove (4) screws from the dash trim bezel and remove the bezel.
3. Remove (2) screws securing the factory radio and disconnect the wiring. (Figure A)
4. Cut and remove all mounting tabs on the radio housing EXCEPT tabs "E". (Figure B)

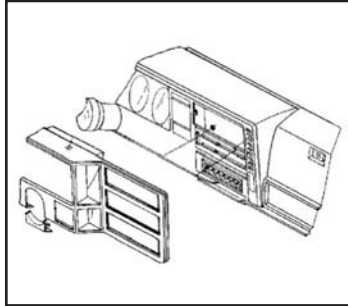

(Figure A)

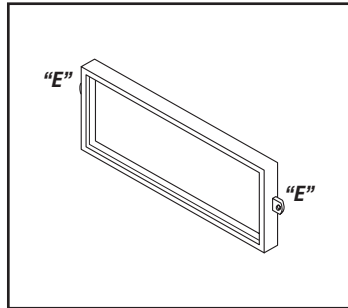

(Figure B)

**Note:** The mounting tabs can be identified by the stamped letter on the back of each tab.

Continue to kit assembly

## Jeep Grand Wagoneer 1987-1995

1. Gently unclip the dash trim bezel.
2. Remove (2) screws securing the factory radio and disconnect the wiring. (Figure A)
3. Cut and remove all mounting tabs on the radio housing EXCEPT tabs "E". (Figure B)

**Note:** The mounting tabs can be identified by the stamped letter on the back of each tab.

Continue to kit assembly

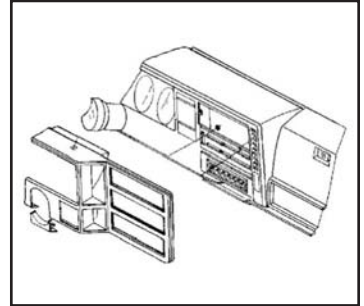

(Figure A)

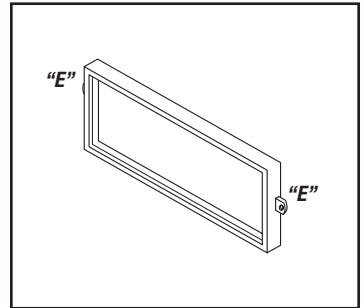

(Figure B)

## Jeep Wrangler 1986-1996

1. Remove (6) Phillips screws from the face of the dash trim bezel. Remove the bezel. (Figure A)
2. Remove (2) screws securing the factory radio and disconnect the wiring.
3. Cut and remove all mounting tabs on the radio housing EXCEPT tabs "B". (Figure B)

**Note:** The mounting tabs can be identified by the stamped letter on the back of each tab.

4. Mount bracket set #1 to the back of the mounting tabs with (2) #8 x 1" Phillips screws supplied. (Figure B)

*Continue to kit assembly*

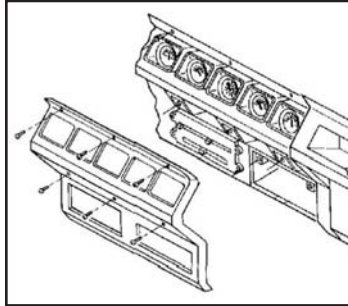

(Figure A)

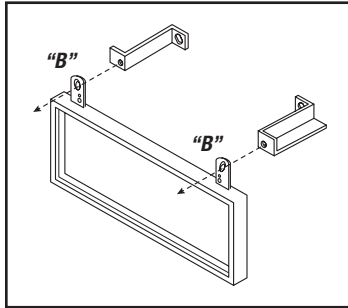

(Figure B)

## Lincoln Continental 1988-1994/Mark VII 1990-1992/Town Car 1990-1994

1. Using Metra's 86-5618, pull the factory radio from the dash and disconnect the wiring. (Figure A)
2. Locate the rounded and cornered faceplates. (Figure B)

*Continue to kit assembly*

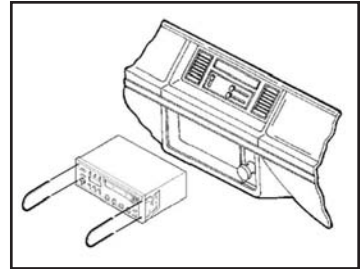

(Figure A)

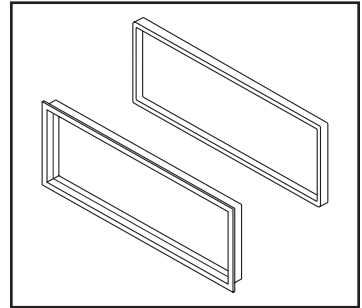

(Figure B)

## Lincoln Continental 1985-1987

1. Remove (2) #8 Phillips screws below the radio opening. Open the ashtray and remove (2) #8 Phillips screws exposed (it is NOT necessary to remove the center screw). (Figure A)
2. Unclip and remove the dash trim bezel. (Figure A)
3. Remove (4) hex-head screws securing the factory radio and disconnect the wiring.
4. Cut and remove all mounting tabs on the radio housing EXCEPT tabs "D" and "F". (Figure B)

*Note: The mounting tabs can be identified by the stamped letter on the back of each tab.*

5. Locate spacer set #2 (the spacers must be placed behind the mounting tabs during installation). (Figure B)

*Continue to kit assembly*

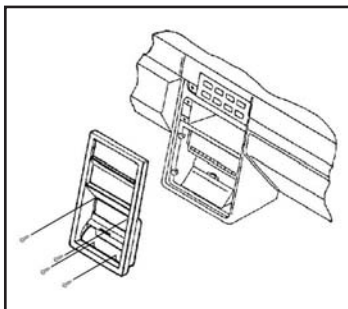

(Figure A)

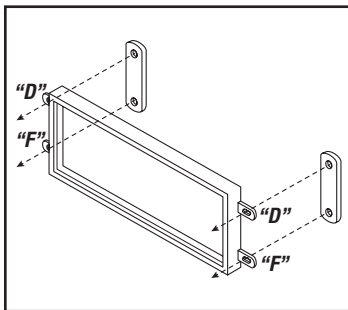

(Figure B)

## Lincoln Mark VII 1984-1989

1. Gently pry out on the dash trim bezel and remove. (Figure A)
2. Remove (4) 5mm hex-head sheet metal screws securing the factory radio and disconnect the wiring.
3. Cut and remove all mounting tabs on the radio housing EXCEPT tabs "D" and "F". (Figure B)

*Note: The mounting tabs can be identified by the stamped letter on the back of each tab.*

4. Locate spacer set #2 (the spacers must be placed behind the mounting tabs during installation). (Figure B)

*Continue to kit assembly*

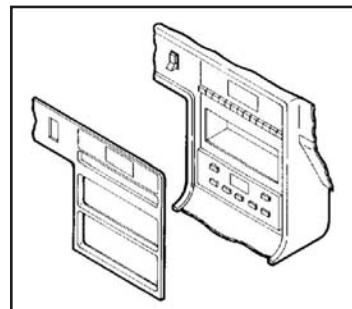

(Figure A)

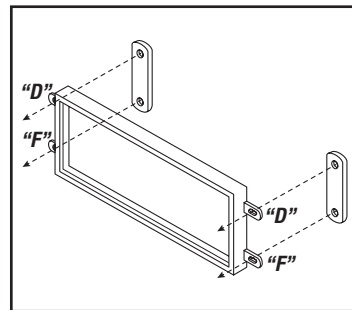

(Figure B)



## Lincoln Mark VIII 1993-1995

1. Using Metra's 86-5618, pull the factory radio from the dash and disconnect the wiring. (Figure A)
2. Locate the rounded and cornered faceplates. (Figure B)

*Continue to kit assembly*

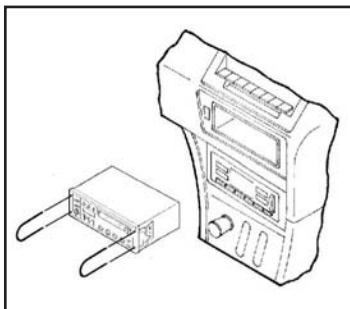

(Figure A)

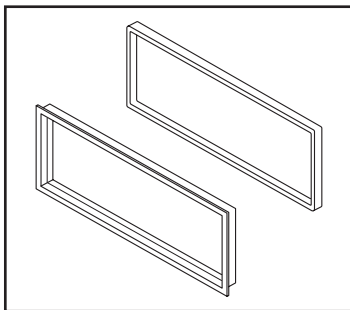

(Figure B)

## Lincoln Town Car 1984-1989

1. Remove (3) #8 Phillips screws from the bottom of the radio trim bezel. Unsnap the plastic strip located above the bezel and remove (3) Phillips screws exposed. (Figure A)
2. Gently pull the instrument cluster trim bezel away from the dash and remove the radio trim bezel. (Figure A)
3. Remove (3) hex-head screws securing the factory radio and disconnect the wiring.
4. Cut and remove all mounting tabs on the radio housing EXCEPT tabs "D" and "F". (Figure B)

**Note:** *The mounting tabs can be identified by the stamped letter on the back of each tab.*

5. Locate spacer set #2 (the spacers must be placed behind the mounting tabs during installation). (Figure B)

*Continue to kit assembly*

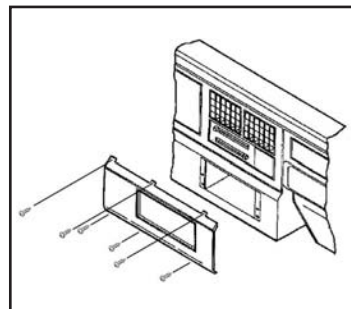

(Figure A)

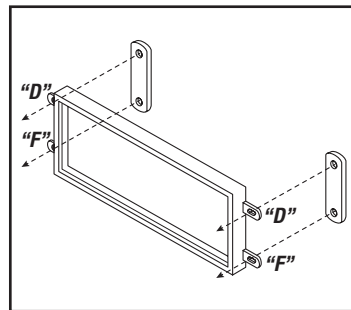

(Figure B)

## Mercury Capri XR2 1991-1994

1. Using Metra's 86-5618, pull the factory radio from the dash and disconnect the wiring. (Figure A)
2. Locate the rounded and cornered faceplates. (Figure B)

*Continue to kit assembly*

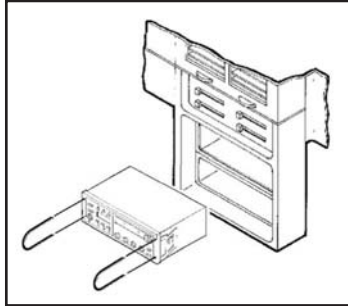

(Figure A)

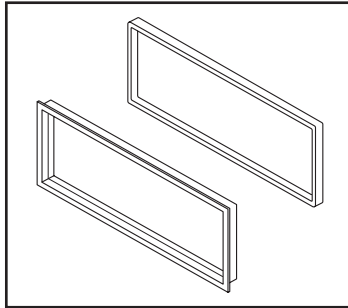

(Figure B)

## Mercury Tracer (hatchback) 1988-1990

1. Remove (3) Phillips screws from the top of the dash trim bezel. Remove the ashtray and (2) Phillips screws from the bottom of the bezel. (Figure A)
2. Remove (4) Phillips screws securing the factory radio and disconnect the wiring.
3. Cut and remove all mounting tabs on the radio housing EXCEPT tabs "C" and "F". (Figure B)

**Note:** The mounting tabs can be identified by the stamped letter on the back of each tab.

*Continue to kit assembly*

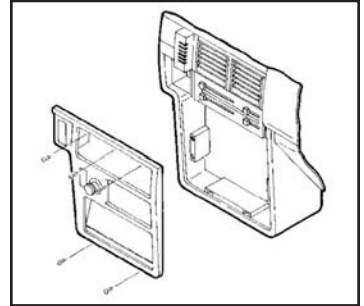

(Figure A)

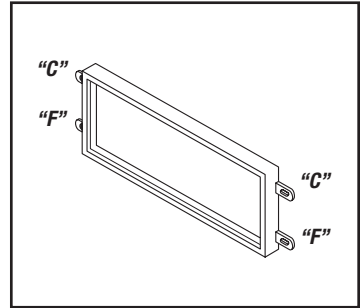

(Figure B)

## Kit Assembly

**(A)** For the Ford Aspire 1992-1996, Bronco 1992-1996, Contour 1995-2000, Crown Victoria 1992-1994, LTD Crown Victoria 1990-1991, Escort 1991-1996, F-Series Pickup, Mustang 1994-2000, Taurus 1990-1995, Tempo 1989-1994, Thunderbird 1989-1997, Windstar 1995-1998, Lincoln Continental 1988-1994, Mark 7 1990-1992, Mark 8 1993-1995, Town Car 1990-1994, Mercury Capri XR2 1991-1994, Cougar 1989-1997, Grand Marquis 1990-1994, Mystique 1995-2000, Sable 1990-1995, Topaz 1989-1994, Tracer 1991-1996, follow these instructions:

1. Remove the metal "DIN" cage from your aftermarket radio.
2. Slide the cage through the desired faceplate and then into the radio opening of the vehicle. Then bend the metal locking tabs down to secure the cage in place. *Then continue to step 3, next page.* (Figure A)

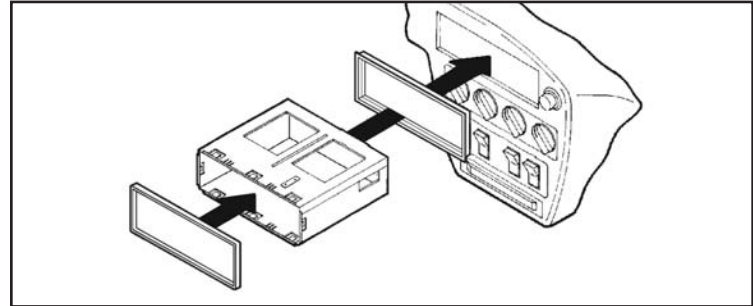

(Figure A)

**(B)** For all other vehicles, follow below:

1. Remove the metal "DIN" cage from your aftermarket radio.
2. Slide the cage into the radio housing, and then bend the metal locking tabs down to secure the cage in place. *Then continue to step 3, next page.* (Figure B)

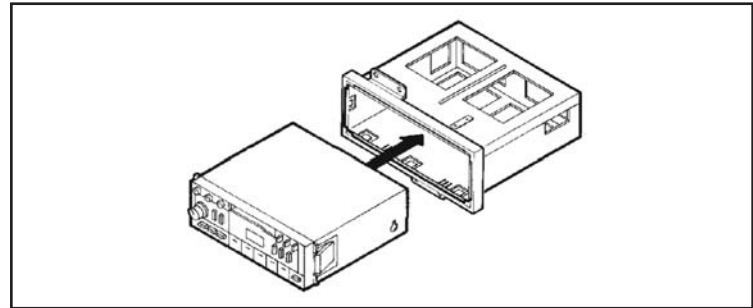

(Figure B)

**All vehicles:**

3. Locate the factory wiring harness in the dash. Metra recommends using the proper mating adapter from Metra or AXXESS. Test the radio for proper operation.
4. Slide the radio into the mounted cage until secure.
5. Reassemble dash in reverse order of disassembly.



Installation instructions for 99-5510



REV 10/9/2014 INST99-5510



### KNOWLEDGE IS POWER

Enhance your installation and fabrication skills by enrolling in the most recognized and respected mobile electronics school in our industry. Log onto [www.installerinstitute.com](http://www.installerinstitute.com) or call 800-354-6782 for more information and take steps toward a better tomorrow.



**Metra recommends MECP certified technicians**