



Ford F-250/350/450/550 XL (w/o color screen) 2017-up

*Visit MetraOnline.com for up-to-date vehicle specific applications.

KIT FEATURES

- ISO DDIN radio provision
- Painted scratch-resistant matte black to match the factory color and finish

KIT COMPONENTS

- A) Radio trim panel • B) Radio brackets • C) Switch trim panel • D) #8 x 3/8" Phillips screws (4) • E) #6 x 3/8" Phillips screws (4) • F) Panel clips (6)

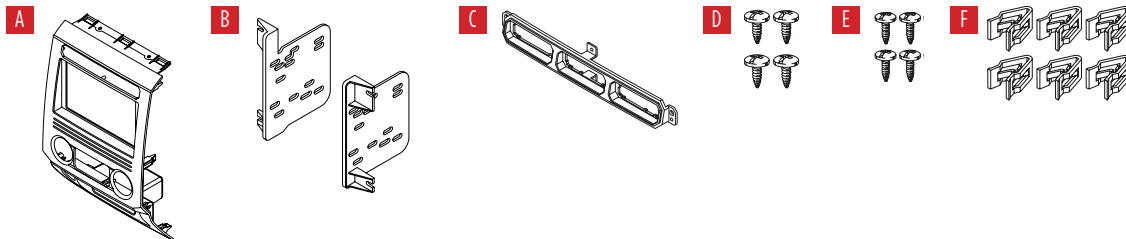

TABLE OF CONTENTS

Dash Disassembly	2
Kit Preparation	2
Kit Assembly	3

WIRING & ANTENNA CONNECTIONS (sold separately)

Visit metraonline.com for audio and steering wheel interface options.

Antenna Adapter: 40-EU10

TOOLS REQUIRED

- Panel removal tool • Phillips screwdriver
- 9/32" socket wrench • Torx screwdriver

Attention! With the key out of the ignition, disconnect the negative battery terminal before installing this product. Ensure that all installation connections are secure before cycling the ignition to test this product.

DASH DISASSEMBLY

1. Remove the storage mat in the pocket above the climate-control/radio trim panel, then remove (2) 9/32" screws exposed. (Figure A)
2. Unclip and remove the pocket, then remove (2) 9/32" screws exposed. (Figure B)
3. Unclip, unplug, and remove the climate-control/radio trim panel.

Continue to Kit Preparation

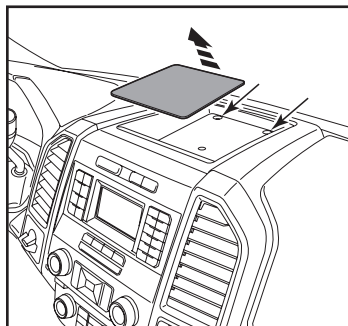

(Figure A)

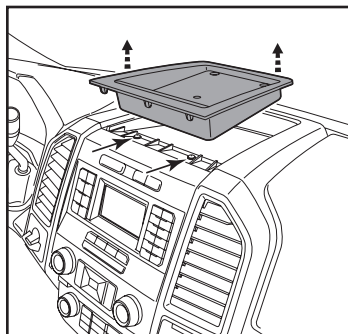

(Figure B)

KIT PREPARATION

From the factory climate-control/radio trim panel:

1. Remove (4) Torx screws securing the climate control panel, then remove. (Figure A)
2. Unclip and remove the switches. (Figure A)
3. Unclip and remove the LINE IN jack. (Figure A)
4. Unclip and remove the power port assembly. (Figure A)

To the 95-5850B climate-control/radio trim panel:

5. Secure the climate control panel to the panel using (4) #6 x 3/8" Phillips screws provided. (Figure B)
6. Secure the **switch trim panel** to the panel using (4) #8 x 3/8" Phillips pan-head screws provided. (Figure B)
7. Snap the factory switches into the switch panel. (Figure B)
8. Snap the LINE IN jack to the panel. (Figure B)
9. Snap the power port assembly to the panel. (Figure B)
10. Attach (6) **panel clips** to the panel.

Continue to Kit Assembly

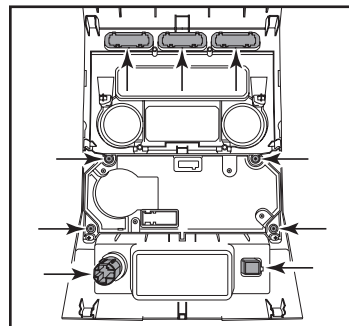

(Figure A)

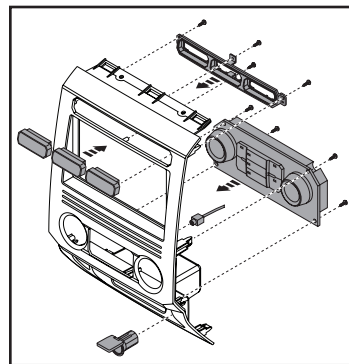

(Figure B)

KIT ASSEMBLY

ISO DDIN radio provision

1. Attach the **radio brackets** to the radio using the screws supplied with the radio. (Figure A)
2. Locate the factory wiring harness and antenna connector in the dash, and complete all necessary connections to the radio. Metra recommends using the proper mating adapter from Metra and/or AXXESS. Test the radio for proper operation.
3. Remove (4) screws in the dash cavity, then secure the completed assembly into the dash using those screws. (Figure B)
4. Snap the **radio trim panel** over the completed assembly, then reassemble the dash in reverse order of disassembly to complete the installation.

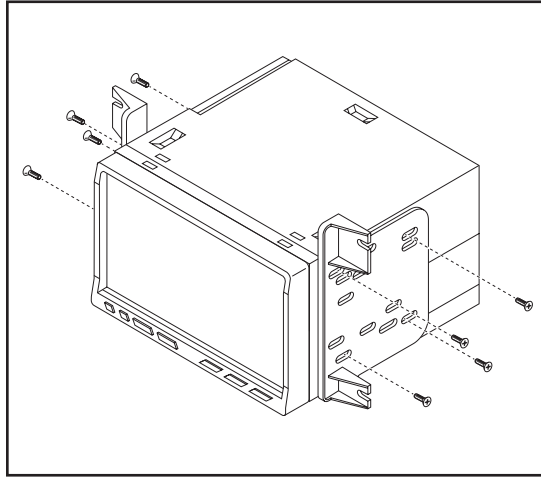

(Figure A)

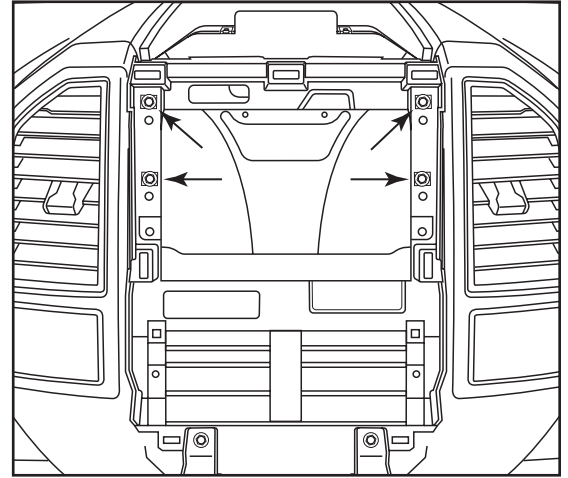

(Figure B)



95-5850B
INSTALLATION INSTRUCTIONS



Having difficulties? We're here to help.



Contact our Tech Support line at:

386-257-1187



Or via email at:

techsupport@metra-autosound.com

Tech Support Hours (Eastern Standard Time)

Monday - Friday: 9:00 AM - 7:00 PM

Saturday: 10:00 AM - 7:00 PM

Sunday: 10:00 AM - 4:00 PM



KNOWLEDGE IS POWER

Enhance your installation and fabrication skills by enrolling in the most recognized and respected mobile electronics school in our industry. Log onto www.installerinstitute.edu or call 386-672-5771 for more information and take steps toward a better tomorrow.



**Metra recommends MECP
certified technicians**



Ford F-250/350/450/550 XL (sin pantalla a color) 2017-up

Visite MetraOnline.com para más información acerca del producto y las aplicaciones específicas más actualizadas del vehículo

CARACTERÍSTICAS DEL KIT

- Provisión de radio ISO DDIN
- Pintado de negro mate resistente a los arañazos para combinar con el color y acabado de fábrica

COMPONENTES DEL KIT

- A) Panel de moldura para radio • B) Soportes del radio • C) Panel de moldura del interruptor • D) Tornillos Phillips #8 de 3/8" (4)
- E) Tornillos Phillips #6 de 3/8" (4) • E) Ganchos para panel (6)

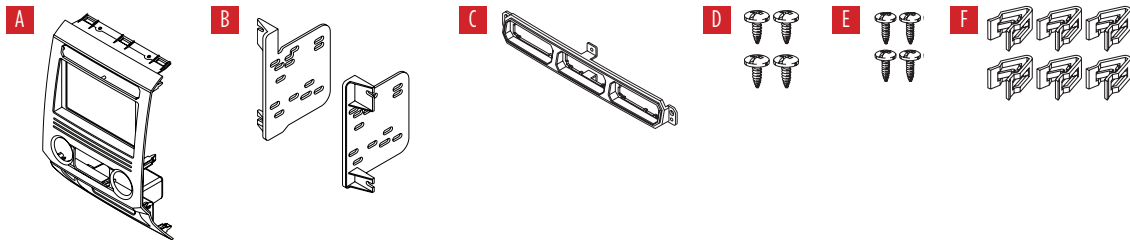

INDICE

Desmontaje del tablero	2
Preparación del kit.....	2
Ensamble del kit	3

CABLEADO Y CONEXIONES DE ANTENA

(se venden por separado)

Árnés de cableado: Visite metraonline.com para conocer las opciones de interfaz de control del volante y audio / video.

Adaptador de antena: 40-EU10

HERRAMIENTAS NECESARIAS

- Herramienta para retiro de paneles
- Destornillador Phillips
- Llave de tubo de 9/32"
- Destornillador Torx

¡Atención! Deje que el vehículo se asiente con la llave fuera del encendido durante unos minutos antes de quitar la radio de fábrica. Al probar el equipo del mercado de accesorios, asegúrese de que todo el equipo de fábrica esté conectado antes de encender el llave de encendido.

DESMONTAJE DEL TABLERO

1. Quite el tapete de almacenamiento en la cavidad que está encima del panel de moldura para radio / control de clima. Después, quite los (2) tornillos de 9/32" expuestos. (Figura A)
2. Desenganche y quite la cavidad; después, quite los (2) tornillos de 9/32" expuestos. (Figura B)
3. Desenganche, desconecte y quite el panel de moldura para radio / control de clima.

Continúe con la preparación del kit

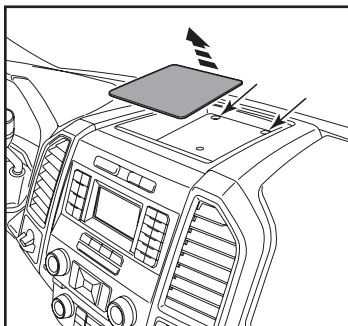

(Figura A)

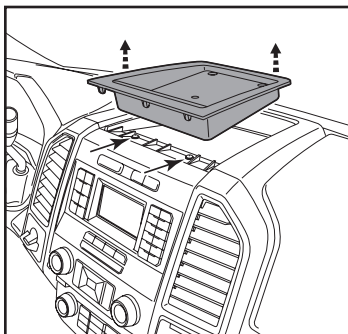

(Figura B)

PREPARACIÓN DEL KIT

Del panel de moldura para radio / control de clima de fábrica:

1. Quite los (4) tornillos Torx que fijan el panel de control de clima y quítelo. (Figura A)
2. Desenganche y quite los interruptores. (Figura A)
3. Desenganche y quite el puerto de entrada de línea. (Figura A)
4. Desenganche y quite el ensamble de puertos de alimentación. (Figura A)

Al panel de moldura de radio / control de clima 99-5850CH:

5. Fije el panel de control de clima al panel con los (4) tornillos Phillips #6 de 3/8" que se incluyen en el kit. (Figura B)
 6. Fije el **panel de moldura del interruptor** al panel con los (4) tornillos Phillips #8 de 3/8" incluidos. (Figura B)
 7. Coloque a presión los interruptores de fábrica en el panel del interruptor. (Figura B)
 8. Coloque a presión el puerto de entrada de línea al panel. (Figura B)
 9. Coloque a presión el ensamble de puertos de alimentación al panel. (Figura B)
 10. Coloque los (6) **ganchos para panel** en el panel.
- Continúe con el ensamble del kit

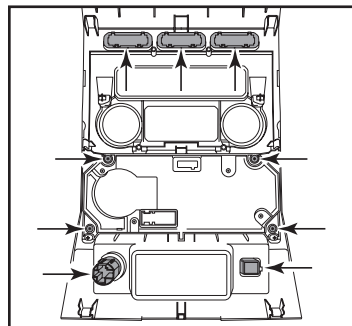

(Figura A)

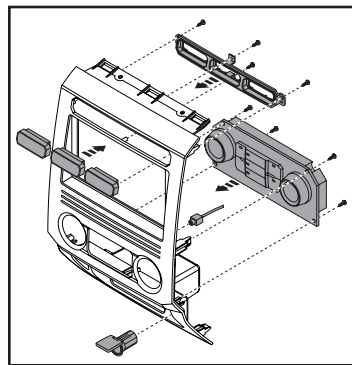

(Figura B)

ENSAMBLE DEL KIT

1. Una los **soportes del radio** al radio usando los tornillos que vienen con el radio. (Figura A)
2. Localice el arnés de cableado de fábrica y el conector de la antena en el tablero y realice todas las conexiones necesarias al radio. Metra recomienda el uso de adaptadores de acoplamiento adecuados de Metra o de Axxess. Pruebe el radio para asegurarse de que funciona bien.
3. Quite los (4) tornillos en la cavidad del tablero. Después, fije el ensamble completo al tablero usando esos mismos tornillos. (Figura B)
4. Coloque a presión el **panel de moldura para radio** encima del ensamble completo. Después, vuelva a ensamblar el tablero en orden inverso al desensamble para terminar la instalación.

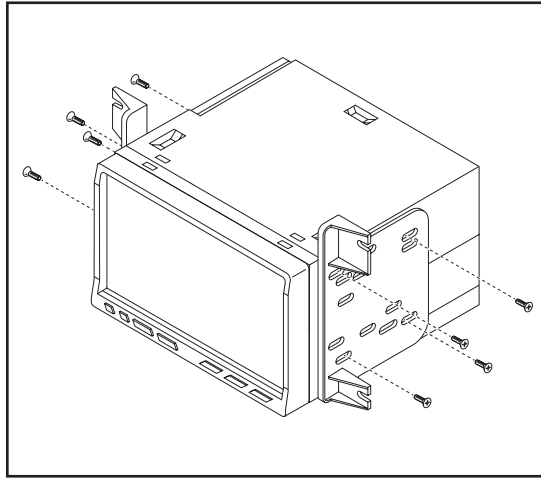

(Figura A)

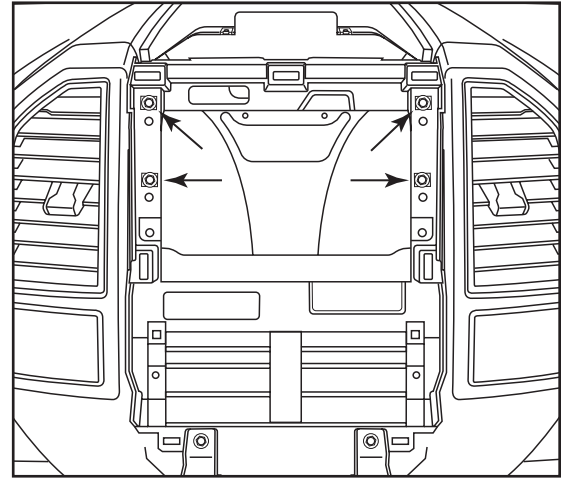

(Figura B)



95-5850B
INSTRUCCIONES DE INSTALACIÓN



¿Tienes dificultades? Estamos aquí para ayudar.



Póngase en contacto con nuestra
línea de soporte técnico en:
386-257-1187



O por correo electrónico a:
techsupport@metra-autosound.com

Horas de soporte técnico (hora estándar del este)

Monday - Friday: 9:00 AM - 7:00 PM

Saturday: 10:00 AM - 7:00 PM

Sunday: 10:00 AM - 4:00 PM



KNOWLEDGE IS POWER

Enhance your installation and fabrication skills by enrolling in the most recognized and respected mobile electronics school in our industry. Log onto www.installerinstitute.edu or call 386-672-5771 for more information and take steps toward a better tomorrow.



**Metra recomienda MECP
técnicos certificados**