

Sensus QR-S

Installation Instructions

Questions about installation or applications? Contact Sensus Technical Support at 1-800-638-3748

805 Liberty Boulevard
DuBois, PA 15801
1-800-375-8875
www.sensus.com/gas

The QR-S is designed to resolve standard regulator performance issues in high-efficiency equipment applications. It should be used for compatible regulators only.

To determine if the QR-S will resolve the problem:

- Temporarily remove the spring tower cap.
- Supervise an operation cycle of the equipment.
- If the performance issue is resolved, the QR-S will address the problem.
- If the performance issue is not resolved, further evaluation is necessary.

Do not operate the regulator without the spring tower cap in place other than for testing the regulator or adjusting the set pressure of the regulator.



Warning

Only qualified personnel should install or service a regulator. Regulators should be installed, operated, and maintained in accordance with applicable codes and regulations, and Sensus instructions.

If the regulator vents gas or a leak develops in the system, it indicates that service is required. Failure to take the regulator out of service immediately may create a hazardous condition. Personal injury, equipment damage, or leakage due to escaping gas or bursting of pressure-containing parts may result if this regulator is over pressured or is installed where service conditions could exceed published specification limits, or where conditions exceed any ratings of the adjacent piping or piping connections.

To avoid such injury or damage, provide pressure-relieving or pressure-limiting devices (as required by the appropriate code, regulation, or standard) to prevent service conditions from exceeding limits.

Additionally, physical damage to the regulator could result in personal injury and property damage due to escaping gas. To avoid such injury and damage, install the regulator in a safe location.

Models 243-8-1(M), 243-8-2(M) and 243-12-2(M) Retrofit Instructions

1. Remove shipping cap from the QR-S.
2. Check the O-ring for dirt or damage before installation.
3. Remove seal and wire (if applicable) from the regulator.
4. Remove and discard tower cover cap and O-ring.
5. Check the spring tower top surface and chamfer for dirt or nicks.

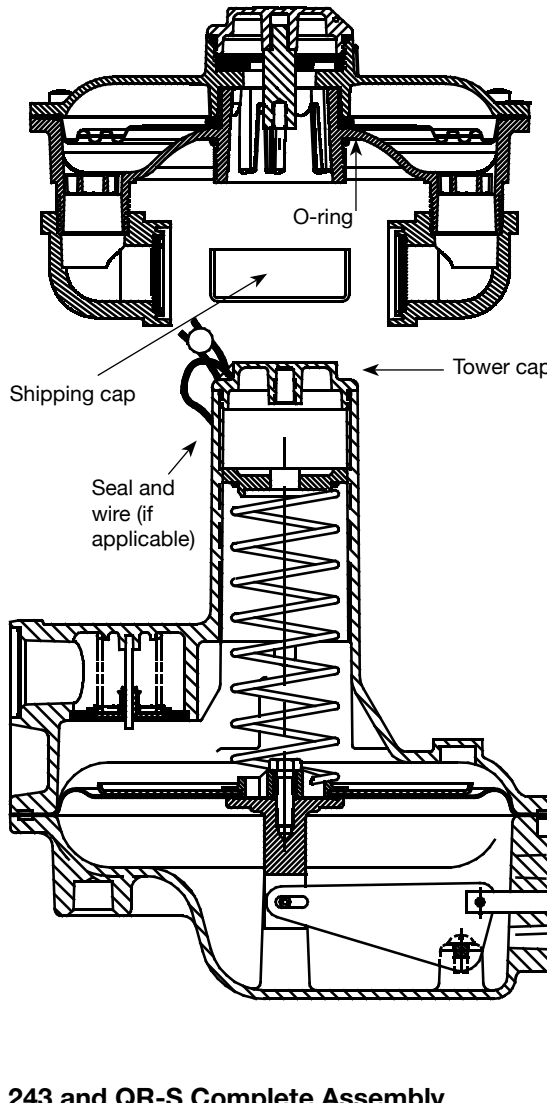

6. Thread QR-S assembly onto main regulator tower. Hand turn, only the QR-S housing to 1/8 to 1/4 turn beyond contact with the O-ring. **DO NOT OVER-TIGHTEN.**

7. Install seal and wire (if applicable).

The regulator can be adjusted with the QR-S installed. Access adjustment by removing QR-S cover cap. (Tool extension may be needed.)

243 and QR-S Complete Assembly

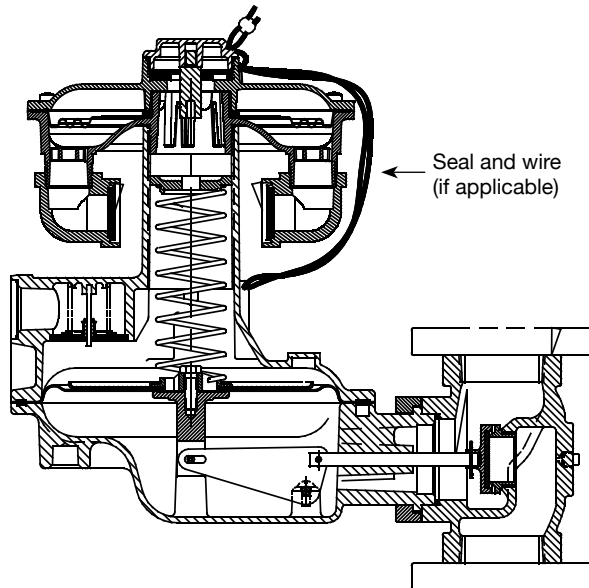

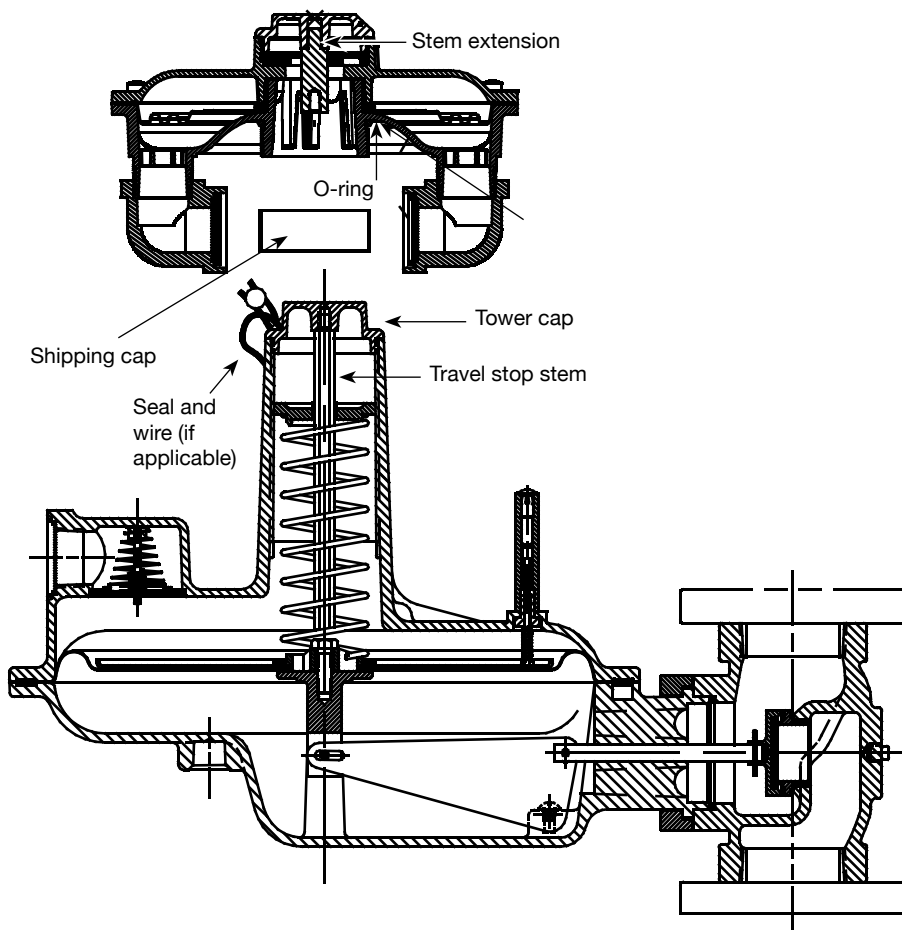

Model 243-12-1 Retrofit Instructions

1. Remove shipping cap from the QR-S.
2. Check the O-ring for dirt or damage before installation.
3. Remove seal and wire (if applicable) from the regulator.
4. Remove tower cap, O-ring and travel stop stem. Remove stem from cap. Discard cap and O-ring.
5. Check the spring tower top surface and chamfer for dirt or nicks.
6. Install stem from Step 4 into stem extension in QR-S expansion chamber. Loctite® #242 is recommended.
7. Thread QR-S assembly onto main regulator tower. Hand turn, only the QR-S housing to 1/8 to 1/4 turn beyond contact with the O-ring. DO NOT OVER-TIGHTEN.
8. Install seal and wire (if applicable).

The regulator can be adjusted with the QR-S installed. Access adjustment by removing QR-S cover cap. (Tool extension may be needed.)

NOTE: Remote vent lines do not need to be connected to the QR-S vents. Only connect remote vent piping to the main regulator upper case 1" NPT vent connection.

243-12-1 and QR-S Complete Assembly

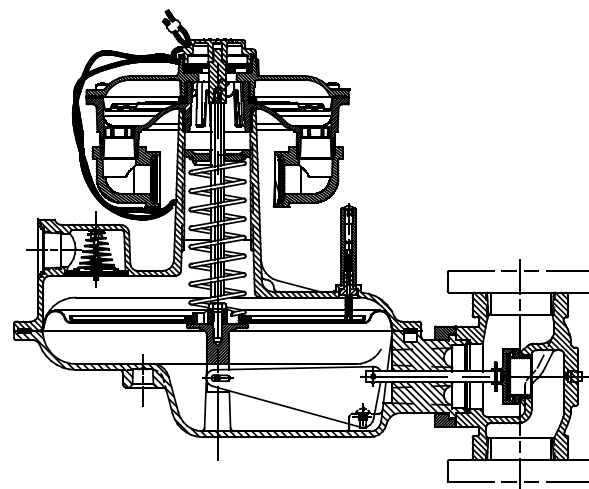

Model 243 Vent Positions

Position as shown

NOTES:

Vent elbows must be repositioned with 243 regulator orientations

Vents need not be tight, nor do their threads need sealed. Direction of vent opening is most important to protect against weather entry.

Remote vent lines do not need to be connected to the QR-S vents. Only connect remote vent pipe to the main regulator upper case 1" NPT vent connection.

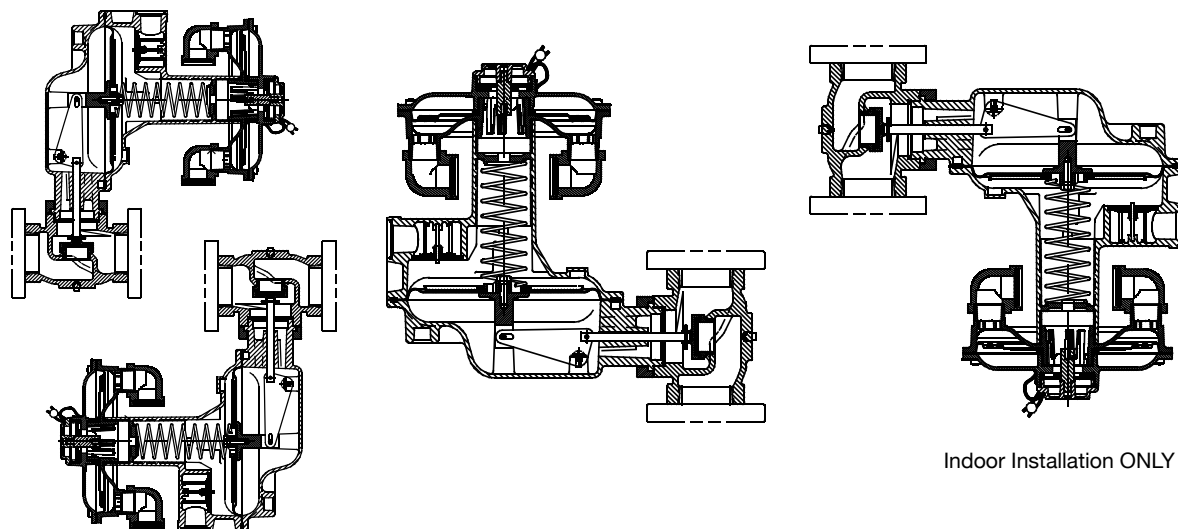

Indoor Installation ONLY

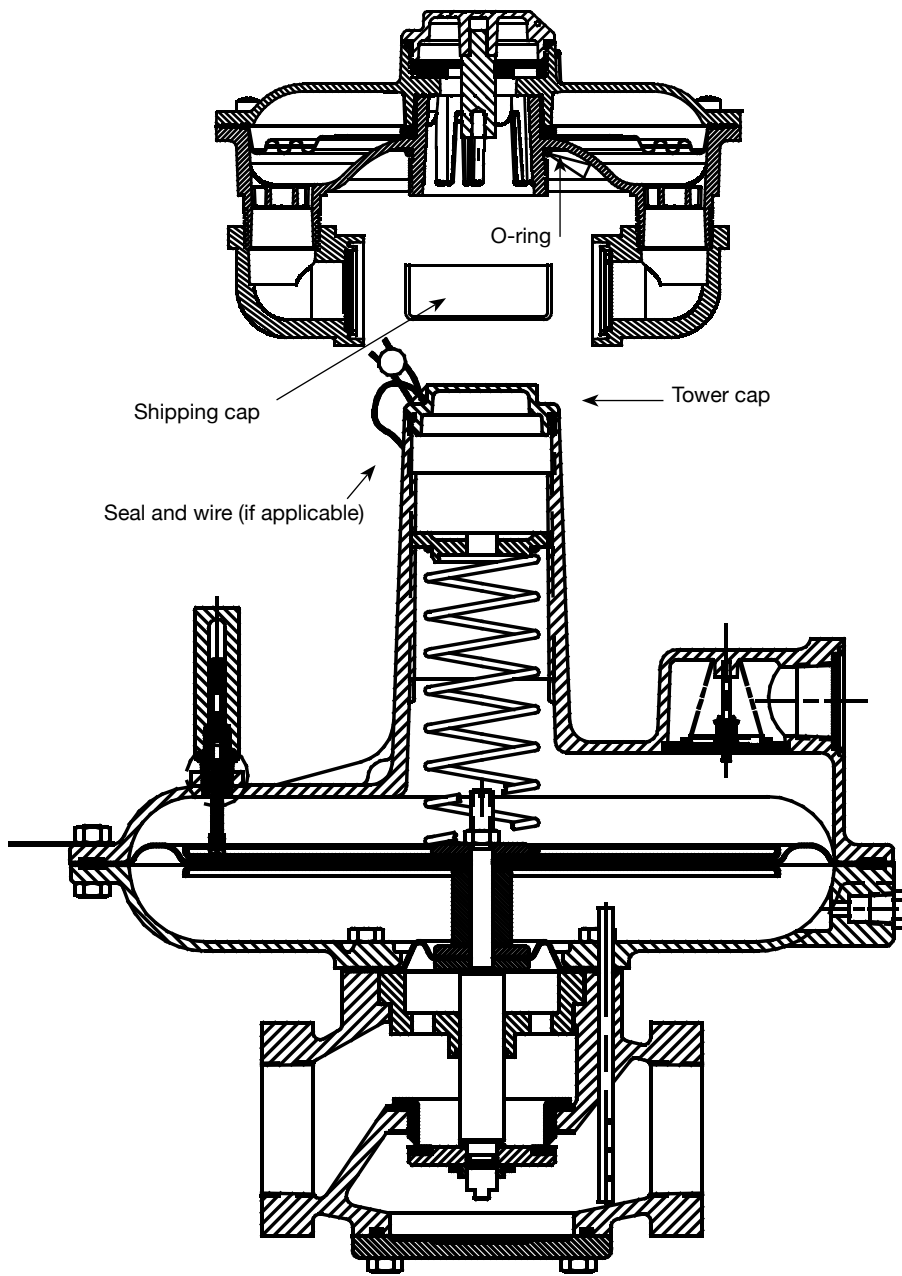

Model 121 and 122 Retrofit Instructions

1. Remove shipping cap from the QR-S.
2. Check the O-ring for dirt or damage before installation.
3. Remove seal and wire (if applicable) from the regulator.
4. Remove and discard tower cover cap and O-ring.
5. Check the spring tower top surface and chamfer for dirt or nicks.
6. Thread QR-S assembly onto main regulator tower. Hand turn, only the QR-S housing to 1/8 to 1/4 turn beyond contact with the O-ring. **DO NOT OVER-TIGHTEN.**
7. Install seal and wire (if applicable).

The regulator can be adjusted with the QR-S installed. Access adjustment by removing QR-S cover cap. (Tool extension may be needed.)

NOTE: Remote vent lines do not need to be connected to the QR-S vents. Only connect remote vent piping to the main regulator upper case 1" NPT vent connection.

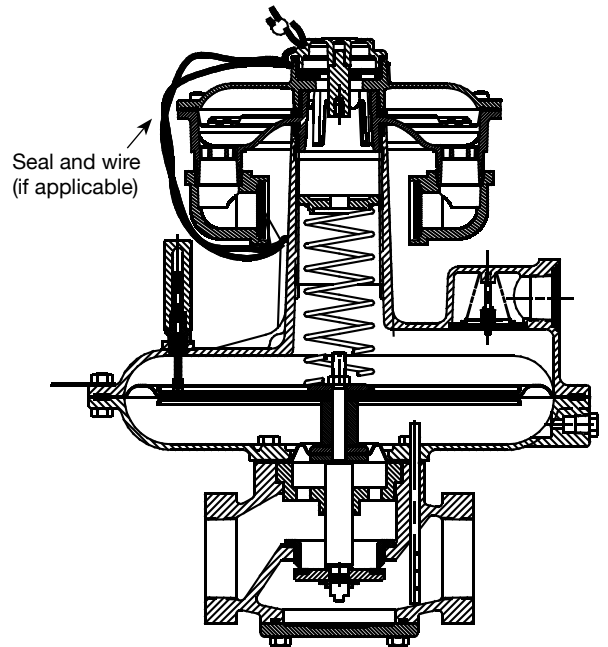

Model 121 and 122 Vent Positions

Position as shown

NOTES:

Vent elbows must be repositioned with 121/122 regulator orientations

Vents need not be tight, nor do their threads need sealed. Direction of vent opening is most important to protect against weather entry.

Remote vent lines do not need to be connected to the QR-S vents. Only connect remote vent pipe to the main regulator upper case 1" NPT vent connection.

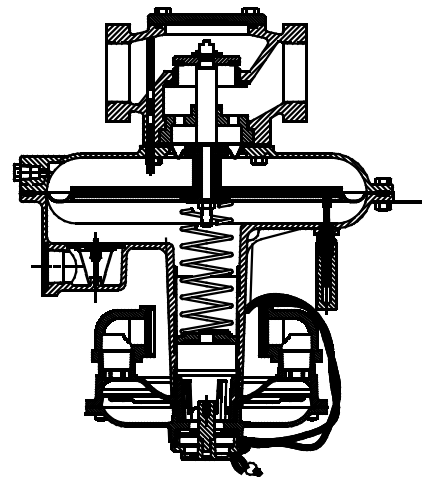
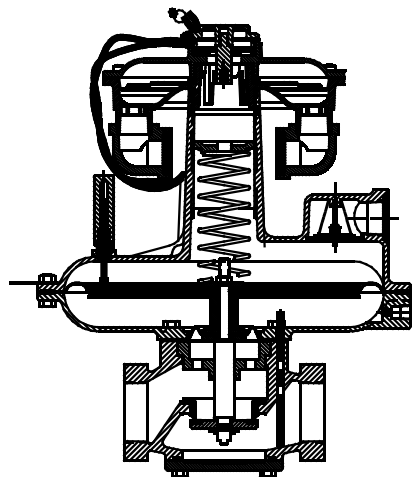

Indoor Installation ONLY

QR-S Complete Assembly

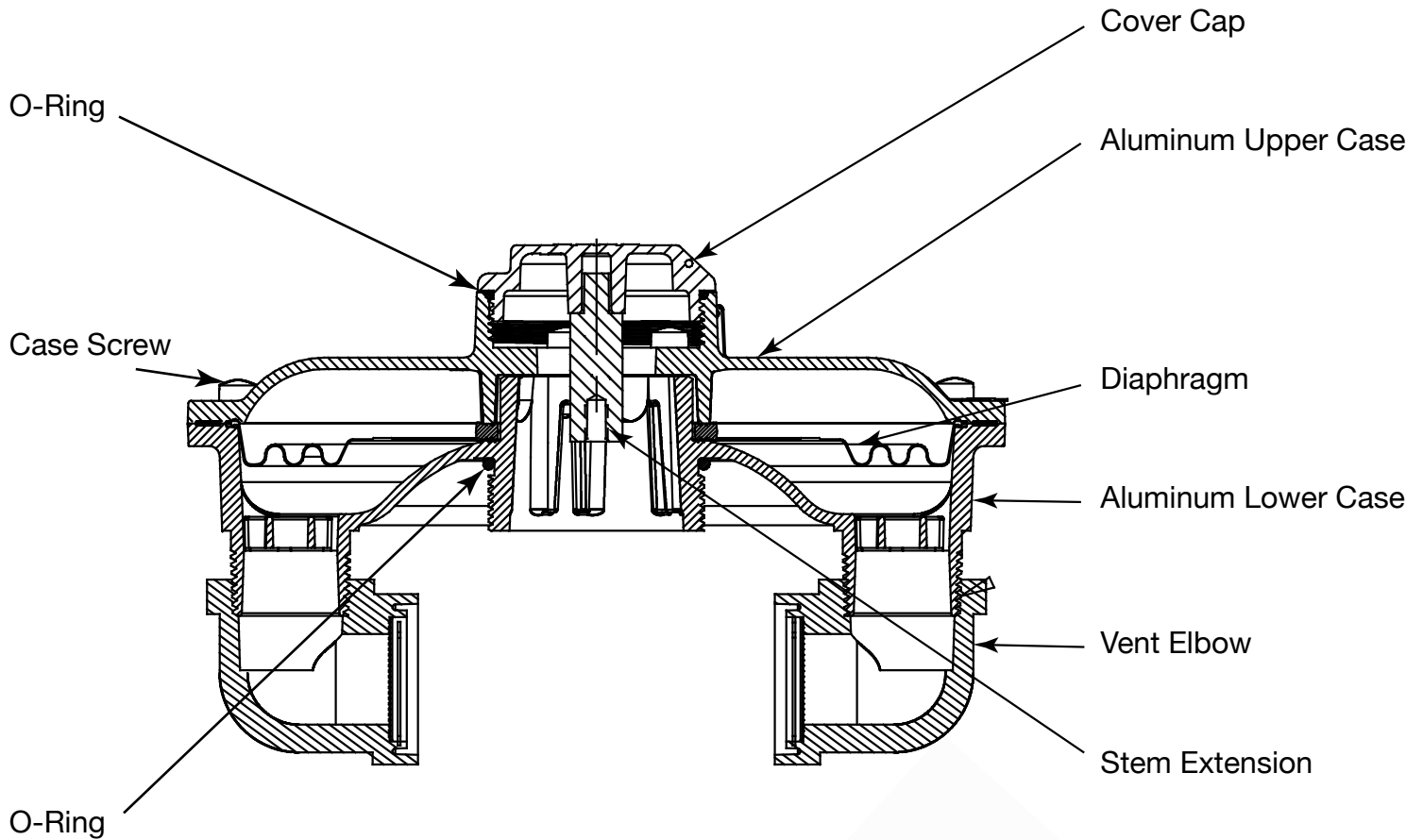

Venting: The Sensus QR-S does not require independent vent piping to the exterior of the building for the following reasons:

1. Very low operating stresses: In normal operation, the QR-S diaphragm has NO significant differential pressure stresses. Less than 0.4 inches water column (0.014 psi) pressure occurs at the QR-S diaphragm as it reacts to the main regulator diaphragm (regardless of the pressures upstream or downstream of the main regulator). Furthermore, there are no linkages connected to the QR-S diaphragm to induce any changing mechanical stresses.
2. Insignificant wear stresses: During normal operation, the QR-S diaphragm does NOT stroke far enough to even make contact with the insides of its cases. Less than +/- 0.5 inches of motion occurs to the QR-S diaphragm from its relaxed position, whereas the clearance to the cases is +/-0.6 inches. Again, this is regardless of the operating pressures of the main regulator. The QR-S simply reacts to the motion of the main regulator diaphragm, allowing for indirect communication of the air above the main regulator diaphragm with ambient atmosphere.
3. Long life and strength: The diaphragm material is very flexible, but yet strong. It has passed flexometer testing to 4 million, very severe, double bending cycles, without any signs of failure. In the application of residential gas meters, this diaphragm material is projected to last years beyond that of prior acceptable materials. The degree of travel flexing and duty cycle in the QR-S application is actually less than that occurring in the gas meter application. Furthermore, at unexpected maximum emergency conditions of 25 psig, this diaphragm material confined within the QR-S will continually hold that pressure.

