

The background of the page is white with several thin, teal-colored wavy lines that curve across the space, creating a modern and clean aesthetic.

Baby Monitor
USER MANUAL

COOAU

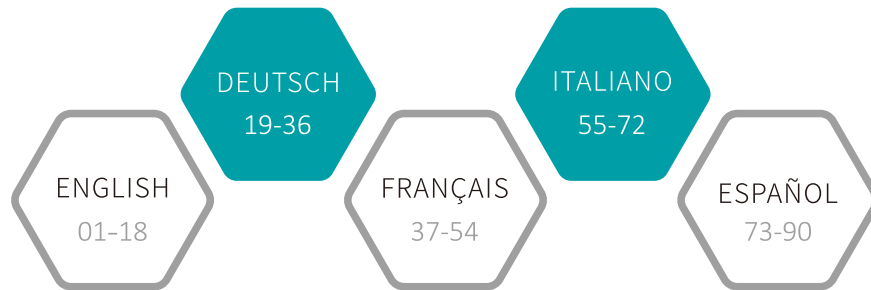



→ ENGLISH

This device complies with part 15 of the FCC Rules. Operation is subject to the following two conditions:







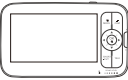
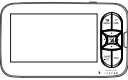
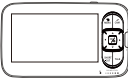
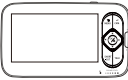
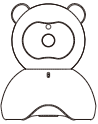
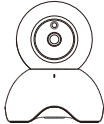

- (1) this device may not cause harmful interference, and
- (2) this device must accept any interference received, including interference that may cause undesired operation.

WARNING

Incorrect use of the product(s) may lead to safety risks. Therefore, we STRONGLY recommend reading the following instructions before using your product.

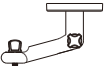
1. Keep the cord(s) away from children in case of strangulation (3 feet/ 1 meter away).
2. Put the product(s) in a dry place in case of short-circuit.
3. Use the AC adapter(s) provided by us ONLY. Using unauthorized charging cables and AC adapters may result in overheat even explosion.
4. Unplug the AC adapter(s) if you don't use it(them).
5. Check your baby's activities regularly as this product is not designed for supervision but for assisting your supervising.

PACKING LIST

Monitor		or		or		or		
Camera		or		or		or		
				or				
AC Power Adapter x2	Mount Kit		Camera Mount				Micro-USB Power Cable x2	User Manual

CAMERA

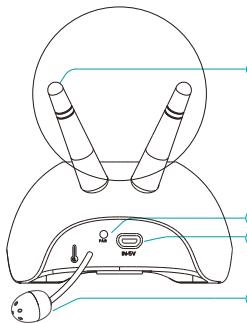
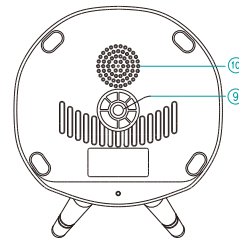
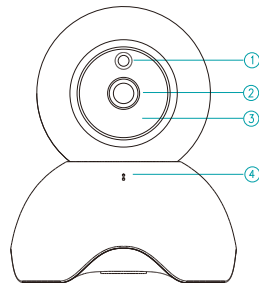
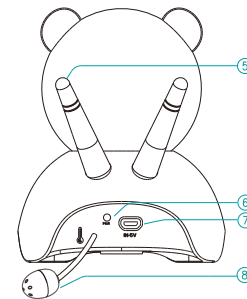
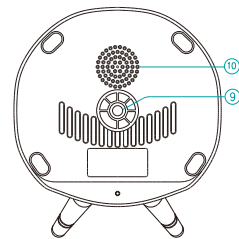
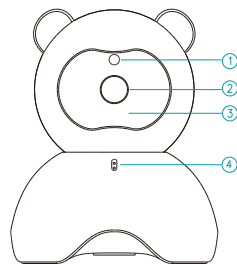

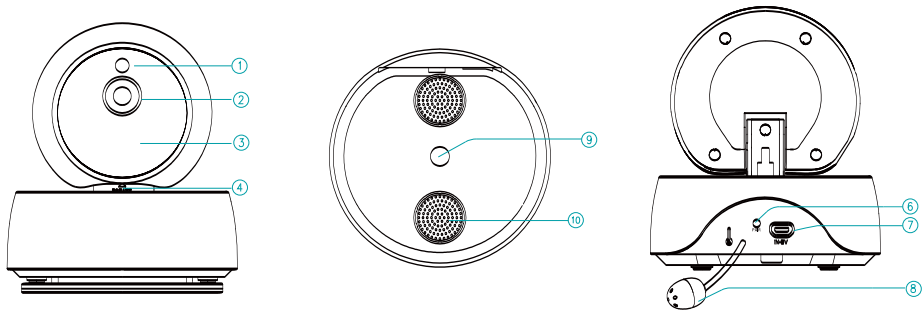
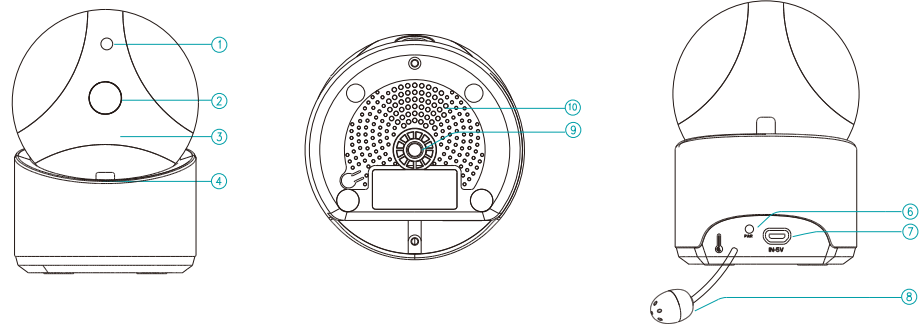

- 1. Night Vision Sensor
- 2. Camera Lens
- 3. IR LED
- 4. Microphone
- 5. Antenna
- 6. Pair Button
- 7. Power Input
- 8. Temperature Sensor
- 9. Mounting Bracket
- 10. Speaker

MONITOR

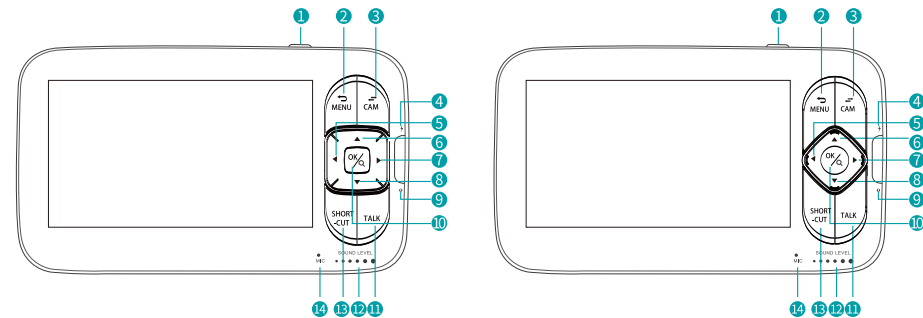
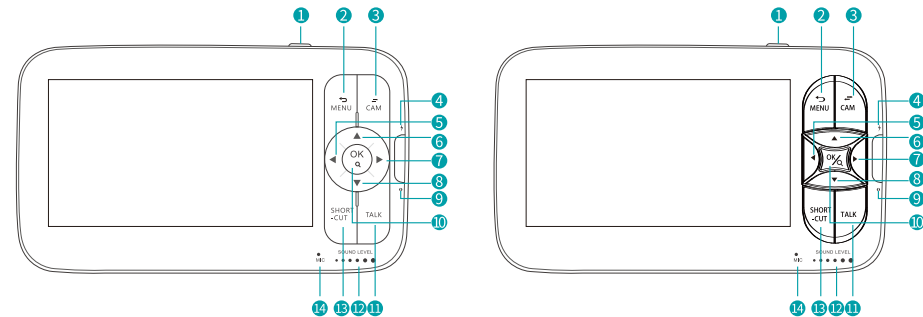

1. **Power/Sleep Button:** Long press to turn on/off the monitor; short press to turn on/off the screen.
2. **Menu/Back:** Press to enter menu page or press as a Back button.
3. **Camera Switch:** Switch cameras if connected with 2 or more cameras.
4. **Charging Indicator:** It gives off yellow light while the monitor is being charged.
5. **Left:** Press to pan the camera leftward or to change your selection leftward.
6. **Up:** Press to tilt the camera upward or to change your selection upward.
7. **Right:** Press to pan the camera rightward or to change your selection rightward.
8. **Down:** Press to tilt the camera downward or to change your selection downward.
9. **Power Indicator:** The green light turns on if connected to electricity.
10. **Zoom/OK:** Press to Zoom in/out or to confirm your selection.
11. **Talk:** Press to talk to your baby in the monitoring image.
12. **Sound Level LED:** Low/high level shows low/high sound detected by the camera.
13. **Volume/Brightness:** Press to adjust the monitor's volume or brightness in the monitoring image.
14. **Microphone**

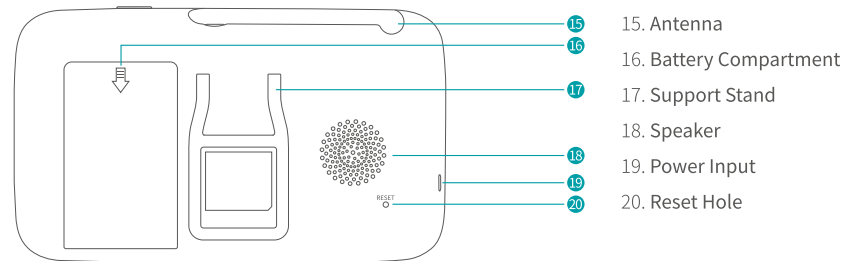
**Note:**

1. If you **RESET** with a pin, the monitor will be forced shutdown.
2. Do not open the battery compartment without official guidance.

GETTING STARTED

Step 1:

1. Connect the camera to the AC adapter.
2. Plug the AC adapter into a socket.

Note: Put the camera away from your baby (3ft/1m away at least).

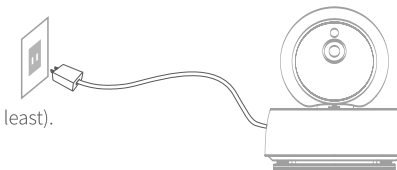
**Step 2:**

1. Connect the monitor to the AC adapter.
2. Plug the AC adapter into a socket.
3. Long press the Power button to turn on the monitor then you can see the monitoring interface.

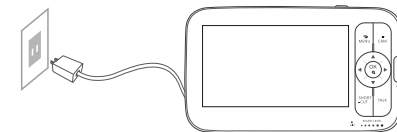
**Note:**

The monitor takes about 4 hours to be fully charged, and it lasts about 4-5 hours.

CAMERA SETTING

Notice:

The camera and monitor were paired already. This function is to add new cameras to the monitor.

1. Add cameras

Step 1:

1. Press  to enter menu page.
2. Choose  and press OK button.

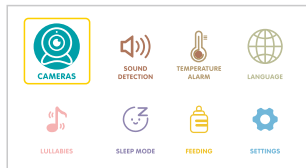

Step 2:

1. Select  then press OK button.

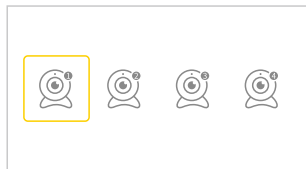

Step 3:

1. Select  and press OK button TWICE.
See Camera is NOT paired.
2. Press OK button to start pairing.

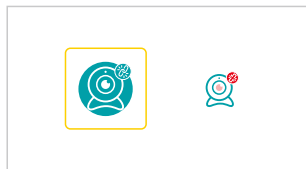

Step 4:

1. Press  PAIR button on the back of the camera.
2. Then see the prompted Paired.

Note: Four cameras at most can be connected to one monitor.

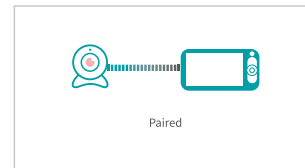

2. Delete cameras

Step 1:

1. Press  to enter menu page.
Choose  and press OK.

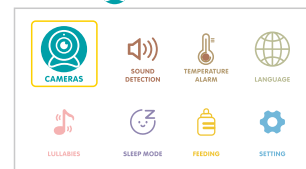

2. Select the camera need deleting.
Press OK.

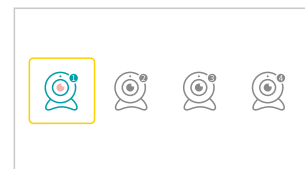

Step 2:

1. Select the right camera icon. Press OK TWICE.

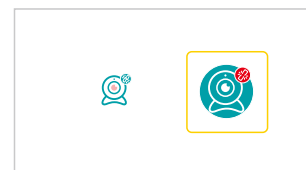

2. See Deleted. Your camera is deleted.

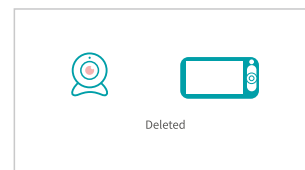

SOUND DETECTION

Explanation:

There are four options of sound detection, OFF, LOW (80dB), MEDIUM (70dB) and HIGH (65dB). OFF means you shut down the function; LOW means the sound can be detected if it reached 80dB, and so on for MEDIUM and HIGH.

Step 1:

1. Press  to enter menu page. Choose  and press OK.

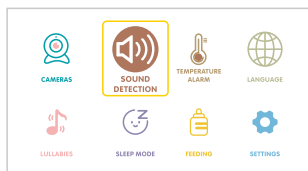

2. Select the option you want. Press OK.

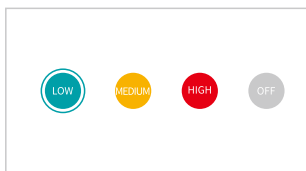

TEMPERATURE ALARM

Explanation:

This function is to send alarms if the temperature is too low (< 15°C/59°F) or too high (> 29°C/84°F).

Step 1:

1. Press  to enter menu page. Choose  and press OK.



2. Select the option you want. Press OK.

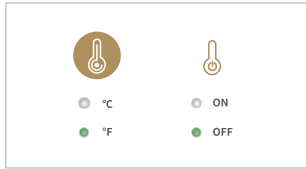

Note: A sound/temperature alarm can be temporarily turned off by pressing any button on the monitor.

LANGUAGE

Explanation:

There are eight languages built in our device, you can choose your language here.

Step 1:

1. Press  to enter menu page.

Choose  and press OK.

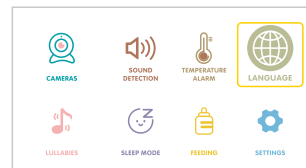

2. Select your language and press OK to confirm.

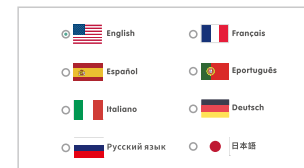

LULLABIES

Explanation:

This function is to comfort your baby when needed.

Step 1:

1. Press  to enter menu page.

Choose  and press OK.

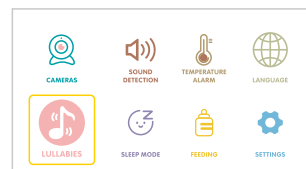

2. Select the lullaby you want.

Select ALL to play the lullabies in a loop.

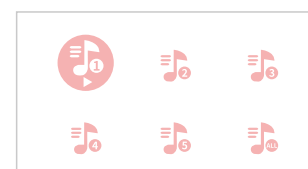

SLEEP MODE

Explanation:

This function is to prolong your monitor's runtime by shutting down the screen.

Step 1:

1. Press **MENU** to enter menu page.

Choose  and press OK.

2. Select the time you want.

Select OFF to turn off Sleep Mode.

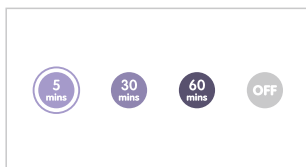
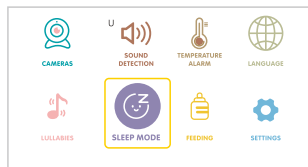

Note: The screen will automatically light up if there is a sound alarm or a temperature alarm.

FEEDING

Explanation:

This function is to remind you of feeding your baby. OFF means you shut down the function; 2.5 hour means it reminds you every 2.5 hours and so on for the other options.

Step 1:

1. Press **MENU** to enter menu page.

Choose  and press OK.

2. Select the time you want.

Select OFF to turn off the feeding reminder.



SETTINGS

Explanation:

This function is to set Date/Time, turn on/off OSD, restore factory settings and provide service support information.

Date/Time:

1. Press **MENU** to enter menu page.

Choose  and press OK.

2. Select Date/Time.

Press OK to enter the interface.

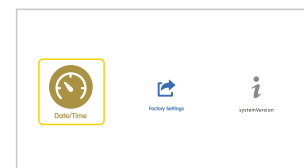

3. Press OK to start/finish setting.

 stands for starting the setting.

4.  stands for finishing the setting.



Note:

* Press Up/Down/Left/Right to select and press OK button to confirm.

* If OSD is ON, the date and time will be displayed on the status bar of the monitor; otherwise, it will not be displayed.

Restore factory settings:

1. Select and conform 

Press OK to enter the interface.

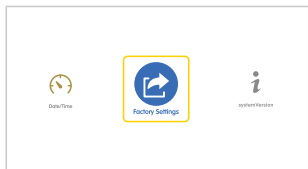

2. Conform YES to reset.

Press  or conform NO to exit.

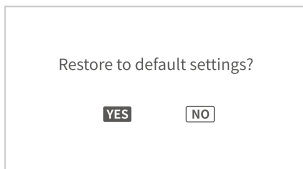

1. Select .

Press OK to enter the interface.

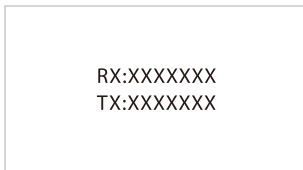
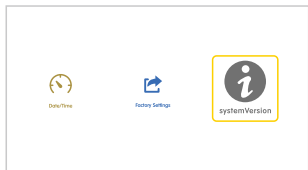

ICONS EXPLANATION

1. Status Bar Icons

: No signal connection

: Signal strength

: Live video loop

: Lullabies enabled

: Sleep Mode enabled

27°C: Current room temperature

: Battery Level

: Sound detection enabled

: Temperature alarm enabled

: Feeding reminder enabled

2. Notifications Icons



: No camera connected

: Sound Alarm

: Temperature Alarm

: Feeding Notification

Explanation:

You can open Live-Video-Loop function through short presses on the  button until you see  on the status bar. When Live-Video-Loop function is on, the connected cameras will automatically switch every 10 seconds. And if there is a sound/temperature alarm, the camera-switch function will pause temporarily.

DIMENSION

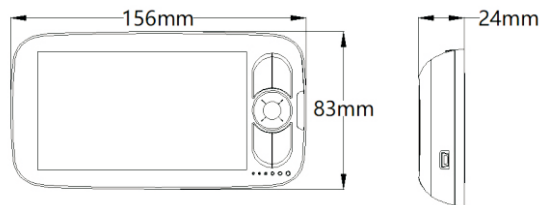

SPECIFICATION

Wireless Camera	
Image Sensor	1/4-inch CMOS H62
Camera resolution	1280*720
Field of viewing angle	70°(Horizontal test)
Night Vision	> 5(IR OFF)/<0(IR ON)
IR Range	5 meter
Video Resolution	1280 x 720P/25fps
Video Code Rate	32kbps-8Mbps
Audio Compression	PCM
Audio Transmission	Two-way voice intercom(Half Duplex)
Sound Sensitivity	-47dBm
Alarm Mode	Voice detection
Wireless Transmission Way	2.4GHz FHSS
Transmission Range	500ft in residential area
	700-900ft in open area

Interface	DC Socket
	Set Button
Power Supply	5V, 1.5A
Working current	400(max)
Temperature Alarm Range	590-840°F/15-29°C
Sound Alarm Range	≧60 dB
Monitor	
Display screen size	5 inch
Display screen description	High-definition screen, good image quality
Resolution	1280*720
Video input	Support one channel
Audio input	Built-in microphone
Interface	1 DC power interface
	1 power switch
	1 menu button
	1 left and right arrow keys
	1 confirmation button
	1 shortcut key
	1 Intercom key
	1 split screen button
Power Supply	5V, 1.5A
Working current	500(max)
Built-in lithium battery	2000mAh
Size	156x83x24(mm)
Weight	256g
General	
Storage Temperature Range	-20° ~ +60°
Operation Humidity	15%~85%

FAQ

Q1. Why did I fail to connect the camera to the monitor?

- * Make sure to plug the power adapter into the camera and socket firmly.
- * Make sure the camera and the monitor is within the effective distance.

Q2. Why is the live video so blurry?

- * Make sure there is no obstacle on the lens of the camera.

Q3. Why did the monitor make noise?

- * The camera and monitor may be too close. Put them further apart.

Q4. Can I hear my baby when I turn off the screen?

- * Yes. You should turn on Sound Detection, and it will wake up the screen and make a sound alarm if a loud sound is detected.

Q5. Why is the picture black and white?

- * The Night Vision Mode will be activated if the camera worked in a dark environment (Brightness \leq 5 Lux).

Q6. How long will the monitor stand by with screen on?

- * The monitor can last about 5 hours, and the time of endurance varies depending on the brightness.

If you meet any problem while using our baby monitor, please don't hesitate to contact us through our support email box. We are extremely willing to solve all the problem you meet.

Support email address: service@cooau.net







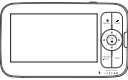
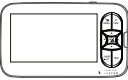
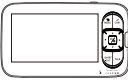
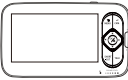
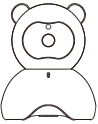
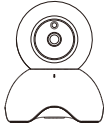

→ DEUTSCH

SICHERHEITSHINWEISE

Die falsche Verwendung des Produkt kann zu Sicherheitsrisiken führen. Derum empfehlen Sie wir DRINGEND, die folgenden Anweisungen lesen, bevor Sie verwenden.

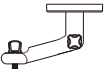
1. Halten Sie Kabel im Falle einer Strangulation von Kindern fern (3 Fuß / 1 Meter).
2. Legen Sie das / die Produkt (e) bei Kurzschluss an einen trockenen Ort.
3. Verwenden Sie AC-Adapter NUR gelieferten von uns. Die Verwendung von nicht zugelassenen Ladekabeln und Gleichstromadaptern kann zu Überhitzung und Explosion führen.
4. Ziehen Sie den AC-Adapter heraus, wenn Sie nicht verwenden.
5. Überprüfen Sie regelmäßig die Aktivitäten Ihres Babys, da dieses Produkt nicht für die Überwachung vorgesehen ist, sondern Sie bei der Überwachung unterstützt.

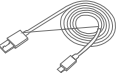
INHALT

Monitor		or		or		or	
Kamera		or		or		or	
AC Adapter x2		Montagesatz 		Kamerahalterun  or 		Micro USB Kabel x2 	Bedienungsanleitung 

KAMERA

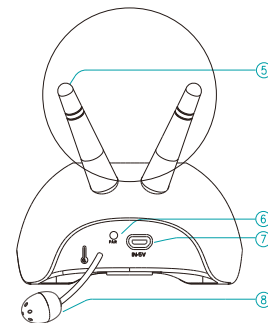
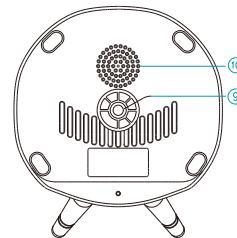
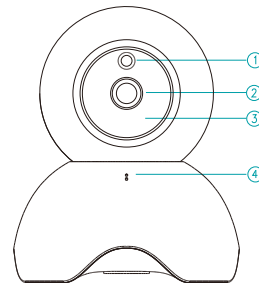
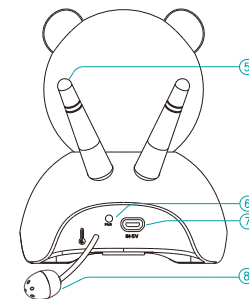
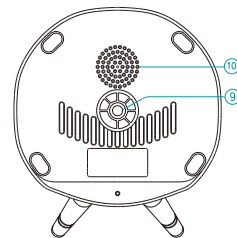
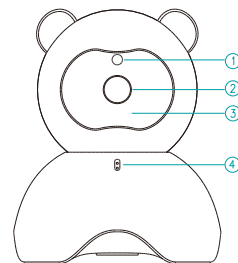

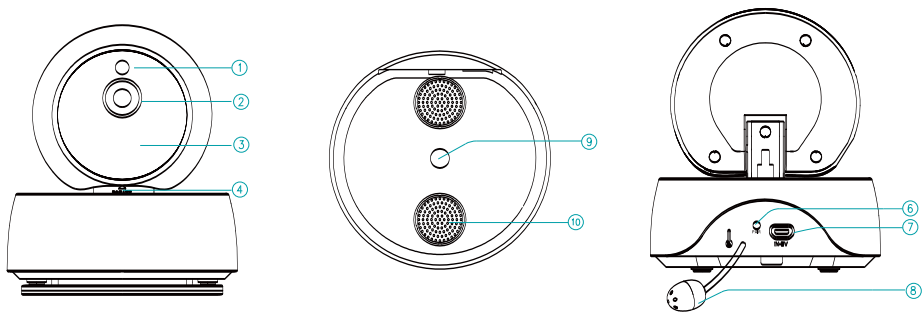
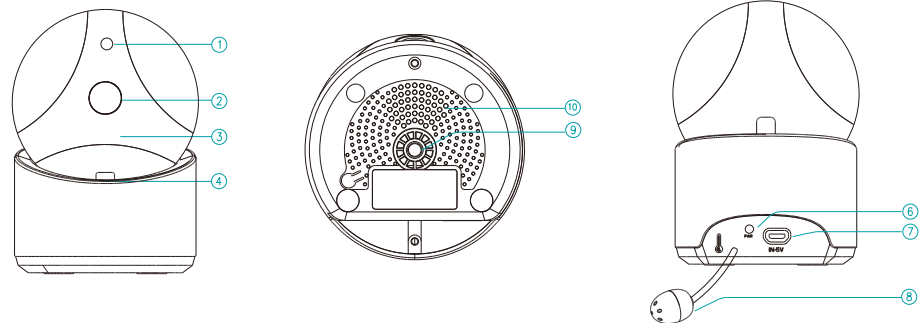

- | | | |
|---------------------|----------------------|------------------|
| 1. Nachtsichtsensor | 5. Antenne | |
| 2. Kameralinsen | 6. Pair Taste | |
| 3. IR LED | 7. Leistungsaufnahme | 9. Montageloch |
| 4. Mikrofon | 8. Temperatur Sensor | 10. Lautsprecher |

MONITOR

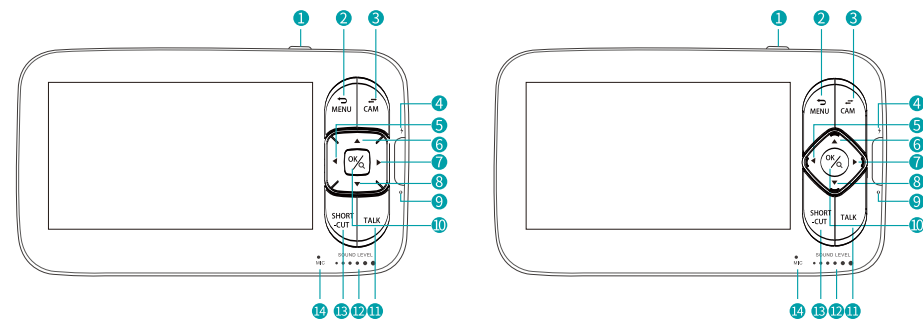
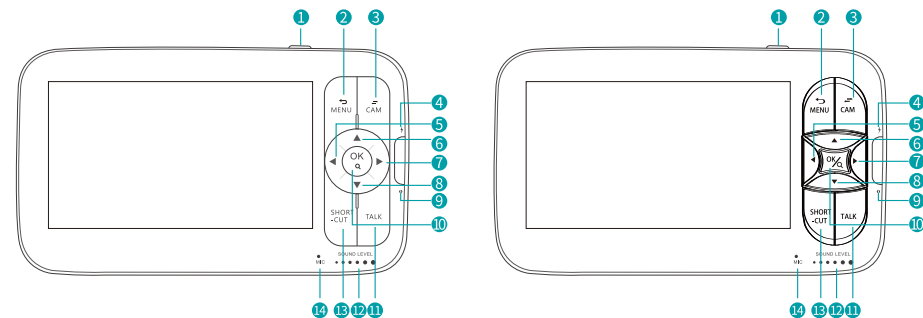

1. **Power/Sleep-Taste:** Lang drücken, um den Monitor ein- oder auszuschalten. kurz drücken, um den Bildschirm ein- /auszuschalten.
2. **Menü/Zurück:** Drücken Sie diese Taste, um die Menüseite aufzurufen, oder drücken Sie sie als Zurück-Taste.
3. **Kameraschalter:** Wechselt die Kamera, wenn zwei oder mehr Kameras angeschlossen sind.
4. **Ladeanzeige:** Sie leuchtet gelb, während der Monitor geladen wird.
5. **Links:** Drücken Sie diese Taste, um die Kamera nach links zu schwenken oder Ihre Auswahl nach links zu ändern.
6. **Nach oben:** Drücken Sie diese Taste, um die Kamera nach oben zu neigen oder Ihre Auswahl nach oben zu ändern.
7. **Rechts:** Drücken Sie diese Taste, um die Kamera nach rechts zu schwenken oder Ihre Auswahl nach rechts zu ändern.
8. **Nach unten:** Drücken Sie diese Taste, um die Kamera nach unten zu neigen oder Ihre Auswahl nach unten zu ändern.
9. **Stromanzeige:** Das grüne Licht leuchtet auf, wenn Strom angeschlossen ist.
10. **Zoom/OK:** Drücken Sie diese Taste, um die Ansicht zu vergrößern/zu verkleinern oder um Ihre Auswahl zu bestätigen.
11. **Sprechen:** Drücken Sie, um mit Ihrem Baby im Überwachungsbild zu sprechen.
12. **Schallpegel-LED:** Niedriger/hoher Pegel zeigt den von der Kamera erkannten niedrigen/hohen Ton an.
13. **Lautstärke/Helligkeit:** Drücken Sie diese Taste, um die Lautstärke oder Helligkeit des Monitors im Überwachungsbild anzupassen.
14. **Mikrofon**

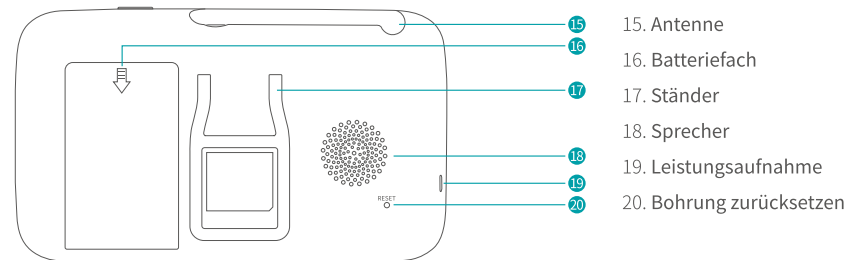

Hinweise :

1. Wenn Sie den **RESET** Knopf drücken, wird das Herunterfahren des Monitors erzwungen.
2. Öffnen Sie das Batteriefach nicht ohne offizielle Anleitung.

AUFLADEN

Schritt 1:

1. Schließen Sie die Kamera an den Gleichstrom Adapter an.
2. Stecken Sie den AC-Adapter in eine Steckdose.

Hinweis: Stellen Sie die Kamera nicht in der Nähe Ihres Babys auf (mindestens 1 m Abstand).

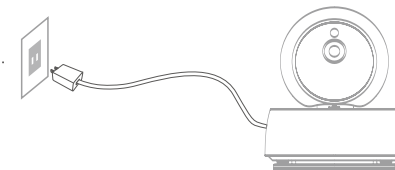

Schritt 2:

1. Schließen Sie den Monitor an den Gleichstromadapter an.
2. Stecken Sie den AC-Adapter in eine Steckdose.
3. Halten Sie die Ein-/Aus-Taste lange gedrückt um den Monitor anzuschalten und das zu überwachende Areal zu sehen.

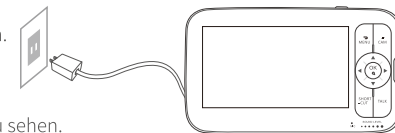

Hinweis: Das vollständige Aufladen des Monitors dauert 4 Stunden. Und es hält ungefähr 4 - 5 Stunden.



KAMERA EINSTELLUNGEN

Beachte:

Die Kamera und der Monitor waren bereits gekoppelt. Diese Funktion dient zum Hinzufügen neuer Kameras zum Monitor.

1. Fügen Sie Kameras hinzu

Schritt 1:

1. Drücken Sie , um die Menüseite aufzurufen.
2. Wählen Sie  und drücken Sie die OK-Taste.



Schritt 2:

1. Wählen Sie  und drücken Sie die Taste OK.

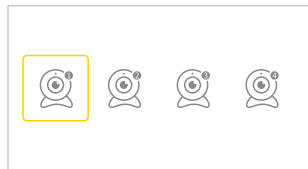

Schritt 3:

1. Wählen Sie  und drücken Sie die OK-Taste.
Siehe **Kamera ist nicht gekoppelt**.
2. Drücken Sie die OK-Taste, um die Kopplung zu starten.

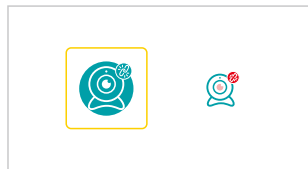

Schritt 4:

1. Drücken Sie die  -Taste am Rückseite der Kamera.
 2. Dann sehen Sie die Aufforderung **Die Kopplung ist Ok.**
- Hinweis:** Maximal vier Kameras können an einen Monitor angeschlossen werden.



2. Lösche Kameras

Schritt 1:

1. MENU drücken, um die Menüseite aufzurufen.
Wählen Sie  und drücken Sie OK.

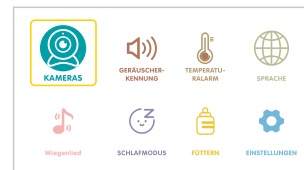

2. Wählen Sie die zu löschende Kamera aus.
Drücke OK.

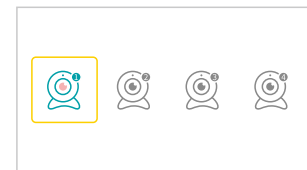

Schritt 2:

1. Wählen Sie das rechte Kamerasymbol.
Drücken Sie zweimal OK.

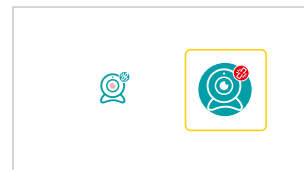

2. Siehe **Das Löschen ist OK.**
Ihre Kamera wird gelöscht.

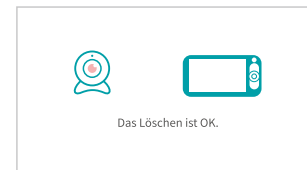



GERÄUSCHERKENNUNG

Erläuterung:

Es gibt vier Optionen für die Tonerkennung: AUS, NIEDRIG (80dB), Standard (70 dB) und HOCH (65dB). AUS bedeutet, dass Sie die Funktion beendet haben. LOW bedeutet, dass der Ton erkannt werden kann, wenn er 80 dB erreicht, und so weiter für Standard und Hoch.

Schritt 1:

1. Drücken Sie , um die Menüseite aufzurufen.
Wählen Sie  und drücken Sie OK.

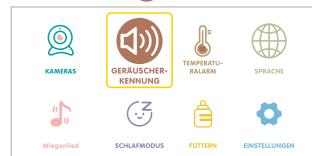

2. Wählen Sie die gewünschte Option.
Drücke OK.

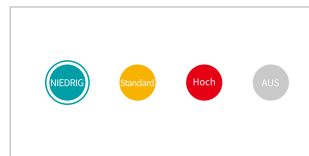



TEMPERATURALARME

Erläuterung:

Diese Funktion dient zum Senden von Alarman, wenn die Temperatur zu niedrig (unter 15 °C) oder zu hoch (über 30°C) ist.

Schritt 1:

1. Drücken Sie , um die Menüseite aufzurufen.
Wählen Sie  und drücken Sie OK.



2. Gewünschte Einheit auswählen und bestätigen.
EIN/AUS bedeutet Öffnen/Schließen des Alarms.

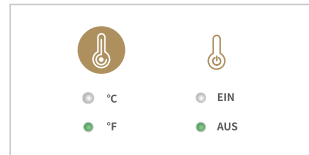



Hinweis: Eine Alarmmeldung kann vorübergehend durch das Drücken einer beliebigen Taste des Monitors ausgeschaltet werden.

SPRACHEN

Erläuterung:

In unserem Gerät sind acht Sprachen integriert. Hier können Sie Ihre Sprache auswählen.

Schritt 1:

1. Drücken Sie , um die Menüseite aufzurufen.
Wählen Sie  und drücken Sie OK.

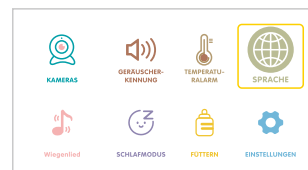

2. Wählen Sie Ihre Sprache und bestätigen Sie mit OK.

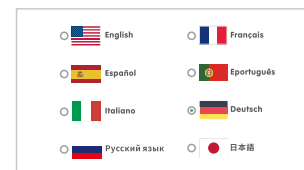



SCHLAFLIEDER

Erklärung:

Diese Funktion soll Ihr Baby bei Bedarf trösten.

Schritt 1:

1. Drücken Sie , um die Menüseite aufzurufen.
Wählen Sie  und drücken Sie OK.



2. Wählen Sie das gewünschte Wiegenlied aus.
Wählen Sie ALL, um das Schlaflied in einer Schleife abzuspielen.

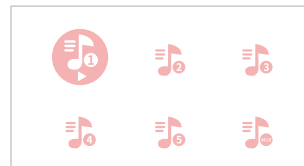

SCHLAFMODUS

Erläuterung:

Mit dieser Funktion können Sie die Laufzeit Ihres Monitors verlängern, indem Sie den Bildschirm herunterfahren.

Schritt 1:

1. Drücken Sie , um die Menüseite aufzurufen.

Wählen Sie  und drücken Sie OK.

2. Wählen Sie die gewünschte Uhrzeit aus.

Wählen Sie AUS, um den Ruhemodus zu deaktivieren.



Hinweis: Der Bildschirm leuchtet automatisch auf, wenn ein akustischer Alarm oder ein Temperaturalarm vorliegt.

FÜTTERUNGSERINNERUNG

Erläuterung:

Diese Funktion soll Sie an das Stillen Ihres Babys erinnern. AUS bedeutet, dass Sie die Funktion beendet haben.

2,5 Stunden bedeutet, dass Sie alle 2,5 Stunden daran erinnert werden, usw. für die anderen Optionen.

Schritt 1:

1. Drücken Sie , um die Menüseite aufzurufen.

Wählen Sie  und drücken Sie OK.

2. Wählen Sie die gewünschte Zeit. Wählen Sie AUS,

um die Fütterungserinnerung auszuschalten.



EINSTELLUNGEN

Erläuterung:

Mit dieser Funktion können Sie Datum und Uhrzeit einstellen, das OSD ein- und ausschalten, die Werkseinstellungen wiederherstellen und Geben Sie Informationen zum Service-Support an.

Terminzeit:

1. Drücken Sie , um die Menüseite aufzurufen.

Wählen Sie  und drücken Sie OK.

2. Wählen Sie Datum/Uhrzeit.

Drücken Sie OK, um die Schnittstelle aufzurufen.

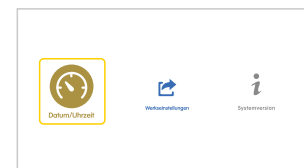

3. Drücken Sie OK, um die Einstellung zu starten/zu beenden.  steht für das Starten der Einstellung.

4.  steht für das Beenden der Einstellung.



Hinweis:

- * Wählen Sie mit **Auf/Ab/Links/Rechts** die Option aus und drücken Sie zur Bestätigung die Taste **OK**.
- * Wenn **OSD** aktiviert ist, werden Datum und Uhrzeit in der Statusleiste des Monitors angezeigt. Andernfalls wird es nicht angezeigt.

Werkseinstellungen wiederherstellen:

1. Auswählen und anpassen 

Drücken Sie **OK**, um die Schnittstelle aufzurufen.

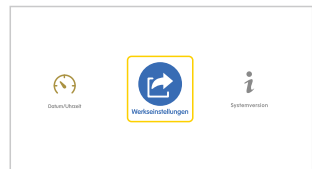

2. Zum Zurücksetzen **JA** bestätigen.

 drücken oder **NEIN** bestätigen, um den Vorgang zu beenden.







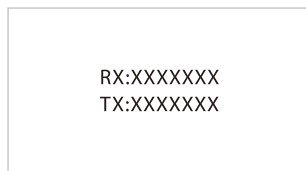
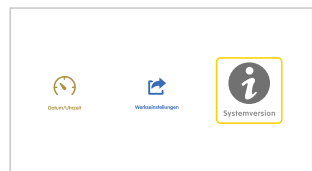



1. Wählen Sie **i**.

Drücken Sie **OK**, um die Schnittstelle aufzurufen.







SYMBOLERLÄUTERUNGEN



1. Statusleistensymbole

-  : Keine Signalverbindung
-  : Signalstärke
-  : Live-Video-Loop
-  : Schlaflied aktiviert
-  : Schlafmodus aktiviert
- 27°C : Aktuelle Raumtemperatur
-  : Batterie Level
-  : Sounderkennung aktiviert
-  : Temperaturalarm aktiviert
-  : Fütterungserinnerung aktiviert

2. Benachrichtigungssymbole

-  : Keine Kamera angeschlossen
-  : Ton Alarm
-  : Temperaturalarm
-  : Fütterungsb Benachrichtigung

Erklärung:

Sie können die Live-Video-Loop Funktion mit Hilfe kurzen Drückens der  Taste einschalten bis Sie  in der Statusleiste sehen können. Wenn die Live-Video-Loop Funktion aktiviert ist, werden die damit verbundenen Kameras automatisch im 10 Sekunden Takt wechseln und Ihnen die Aufnahmen übertragen. Sollte es eine Alarmmeldung geben, wird der Kamerawechsel vorübergehend eingestellt.

ABMESSUNGEN

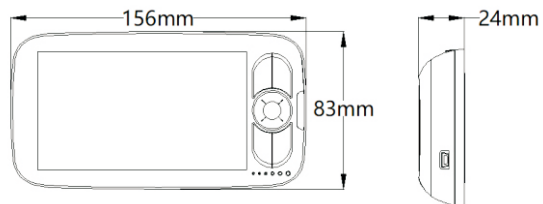

SPEZIFIKATION

Drahtlose Kamera	
Bildsensor	1/4 Zoll CMOS H62
Kameraauflösung	1280*720
Blickwinkel	70°(Horizontaltest)
Nachtsicht	> 5(IR OFF)/<0(IR ON)
IR-Bereich	5 meter
Videoauflösung	1280 x 720P/25fps
Videoencodegeschwindigkeit	32kbps-8Mbps
Audiokomprimierung	PCM
Audioübertragung	Gegensprechanlage (Halbduplex)
Schallempfindlichkeit	-47dBm
Alarmmodus	Spracherkennung
Drahtloser Übertragungsweg	2.4GHz FHSS
Sendereichweite	500ft in Wohngegend
	700-900ft im offenen Bereich

Schnittstelle	DC-Buchse
	Set-Taste
Netzteil	5V, 1.5A
Arbeitsstrom	400(max)
Temperaturalarmbereich	590-840°F/15-29°C
Schallalarmbereich	≥ 60 dB
Monitor	
Bildschirmgröße	5 Zoll
Bildschirmbeschreibung anzeigen	High-Definition-Bildschirm, gute Bildqualität
Auflösung	1280*720
Videoeingang	Unterstützen Sie einen Kanal
Audioeingang	Eingebautes Mikrophon
Schnittstelle	1 Gleichstromschnittstelle
	1 Netzschalter
	1 Menütaste
	1 linke und rechte Pfeiltaste
	1 Bestätigungstaste
	1 Tastenkürzel
	1 Intercom-Taste
1 geteilte Bildschirmtaste	
Netzteil	5V, 1.5A
Arbeitsstrom	500(max)
Eingebaute Lithiumbatterie	2000mAh
Größe	156x83x24(mm)
Gewicht	256g
Allgemeines	
Lagertemperaturbereich	-20° ~ +60°
Betriebsfeuchtigkeit	15%~85%

FAQ

Q1. Warum verbindet sich die Kamera nicht mit dem Monitor?

- * Vergewissern Sie sich das der Stecker fest in der Kamera und dem Netzteil steckt.
- * Vergewissern Sie sich, dass die Kamera und der Monitor die richtige Entfernung haben.

Q2. Warum ist das Live Video verschwommen?

- * Vergewissern Sie sich das nichts vor den Linsen oder vor der Kamera steht.

Q3. Warum macht der Monitor Geräusche?

- * Die Kamera und der Monitor steht zu nah nebeneinander. Stellen Sie beide weiter auseinander.

Q4. Kann ich mein Baby hören, wenn ich den Bildschirm ausschalte?

- * Ja. Sie sollten die Geräuscherkennung aktivieren. Sie weckt den Bildschirm und gibt einen akustischen Alarm aus, wenn ein lautes Geräusch erkannt wird.

Q5. Warum ist das Bild schwarz - weiss?

- * Der Nachtsichtmodus schaltet sich ein, wenn die Kamera in einer dunklen Umgebung an ist. (Helligkeit ≤ 5 Lux)

Q6. Wie lange bleibt der Monitor bei eingeschaltetem Bildschirm im Standby-Modus?

- * Der Monitor kann ca. 5 Stunden lang betrieben werden und die Lebensdauer hängt von der Helligkeit ab.

Wenn Sie bei der Verwendung unseres Babyphone auf ein Problem stoßen, zögern Sie bitte nicht, uns über unsere Support-E-Mail-Box zu kontaktieren. Wir sind sehr bereit, alle Probleme zu lösen, denen Sie begegnen.
Support-E-Mail-Adresse: service@cooau.net











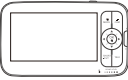

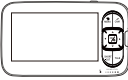
→ FRANÇAIS

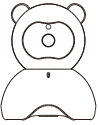
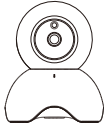
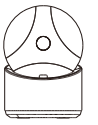
ATTENTION

L'utilisation incorrecte du produit peut entraîner des risques en sécurité. Nous vous recommandons VIVEMENT de lire les instructions ci-dessous avant votre utilisation.

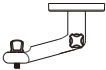
1. Gardez le(s) corde(s) hors de portée des enfants en cas de strangulation (à 3 pieds ou 1 mètre).
2. Placez le (s) produit (s) dans un endroit sec en cas de court-circuit.
3. Utilisez UNIQUEMENT le(s) adaptateur(s) fourni(s) par nous. L'utilisation de câbles de charge et d'adaptateurs non autorisés peut entraîner une surchauffe, voire une explosion.
4. Débranchez le(s) adaptateur(s), si vous ne le(s) utilisez pas.
5. Faites attention régulièrement aux activités de votre bébé, car le produit n'est pas conçu pour la surveillance, mais pour vous aider en surveillance.

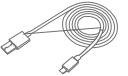
LISTE DE PAQUET

Moniteur		or		or		or	
Caméra		or		or		or	
Adaptateurs AC x2						or	
							
					Câbles de micro-USB x2		Mode d'emploi

CAMERA

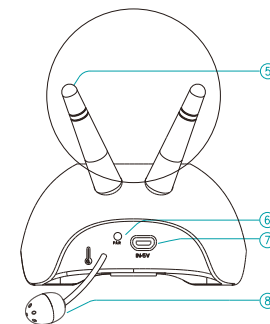
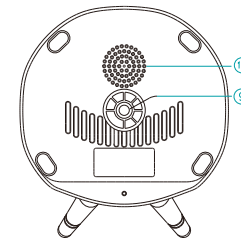
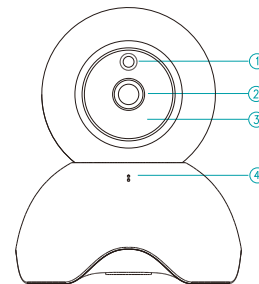
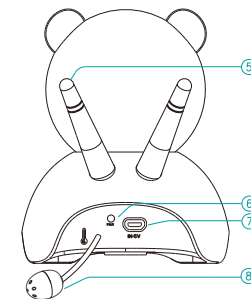
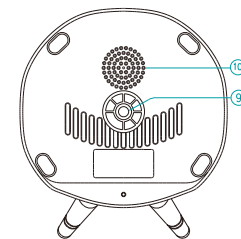
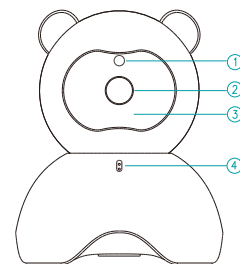

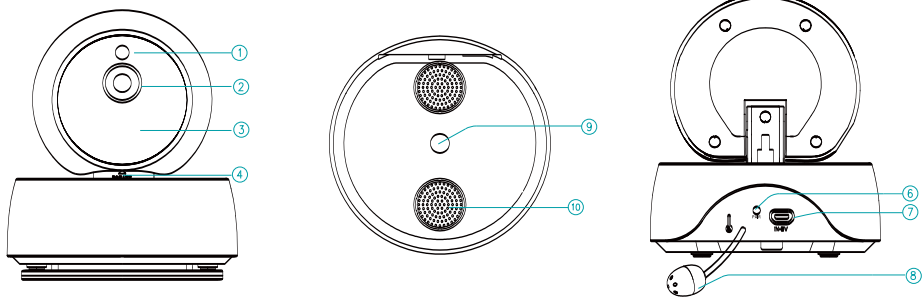
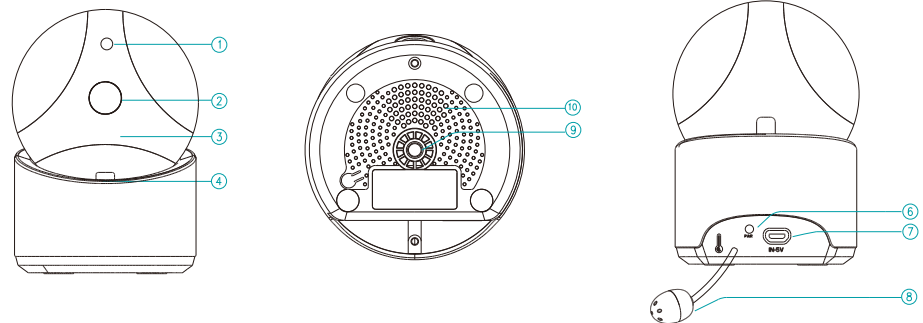

1. Capteur de vision nocturne
2. La lentille de la caméra
3. IR LED
4. Microphone

5. Antenne
6. Bouton appariement
7. L'entrée de courant
8. Capteur de température

9. Support de fixation
10. Parleur

MONITEUR

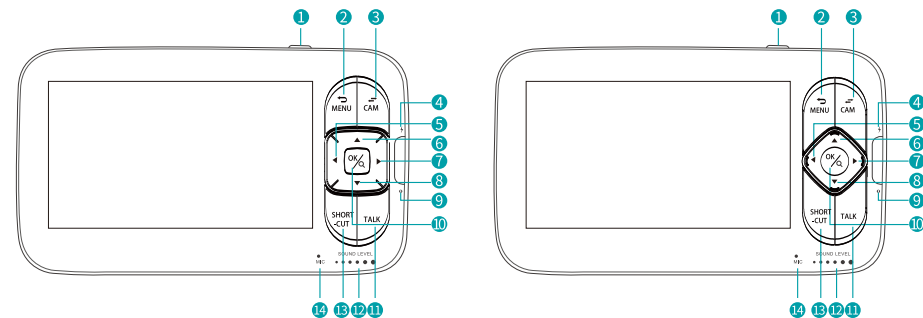
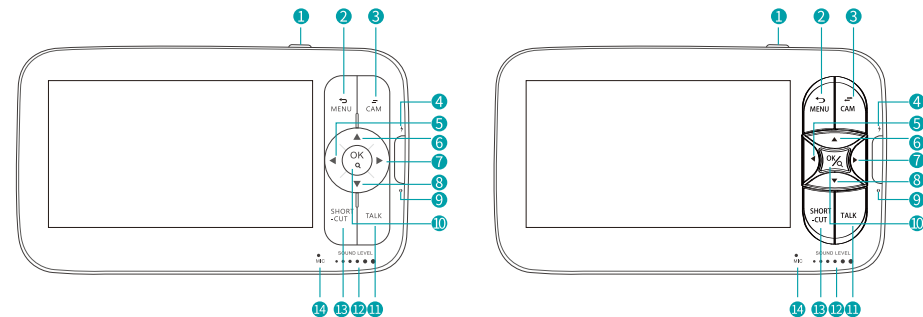

1. **Bouton d'alimentation / veille:** Appui long pour allumer/éteindre le moniteur; appuyez brièvement pour allumer / éteindre l'écran.
2. **Menu / Retour:** Appuyez sur le bouton pour entrer la page de menu ou pour retourner au dernier page.
3. **Commutateur de caméra:** Commutez les caméras s'il y a 2 caméras ou plus.
4. **Indicateur de charge:** Il émet une lumière jaune pendant le chargement du moniteur.
5. **Gauche:** Appuyez pour incliner la caméra à gauche ou pour changer le choix à gauche.
6. **Haut:** Appuyez pour incliner la caméra vers le haut ou pour changer votre sélection vers le haut.
7. **Droite:** Appuyez pour incliner la caméra ou pour changer votre sélection vers la droite.
8. **Bas:** Appuyez pour incliner la caméra vers le bas ou pour changer votre sélection vers le bas.
9. **Indicateur d'alimentation:** Le voyant vert s'allume s'il est connecté à l'électricité.
10. **Zoom / OK:** Appuyez pour effectuer un zoom avant ou arrière ou pour confirmer votre sélection.
11. **Parler:** Appuyez pour parler à votre bébé dans l'image de surveillance.
12. **LED qui indique le niveau sonore:** Le niveau bas / haut indique le son faible/élevé détecté par la caméra.
13. **Volume / Lumiosité:** Appuyez pour régler le volume ou la luminosité de l'affichage du moniteur.
14. Microphone

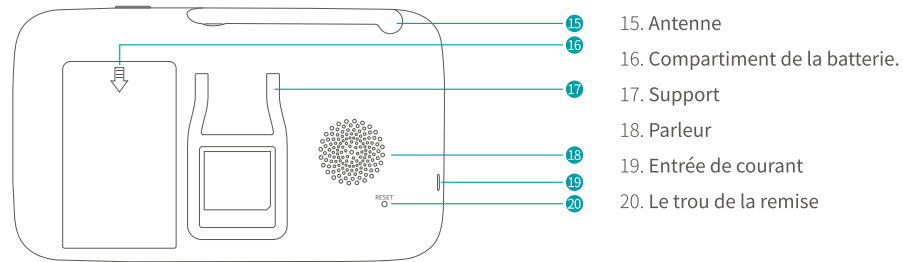

15. Antenne
16. Compartiment de la batterie.
17. Support
18. Parleur
19. Entrée de courant
20. Le trou de la remise

Remarques:

1. Si vous appuyez sur **RESET** avec une broche, le moniteur pourra être éteint par force.
2. Il est interdit d'ouvrir le compartiment de cellule sans instruction officielle.

CHARGEMENT

Étape 1:

1. Connectez la caméra à l'adaptateur.
2. Branchez l'adaptateur AC dans une prise.

Remarque: Éloignez la caméra hors de portée de votre bébé (au moins de 3ft / 1 mètre).

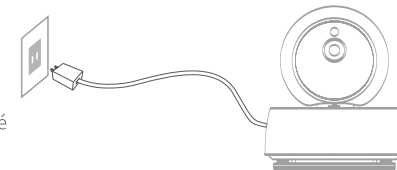

Étape 2:

1. Connectez le moniteur à l'adaptateur AC.
2. Branchez l'adaptateur AC dans une prise.
3. Cliquez sur le bouton d'alimentation pour démarrer le moniteur et voir l'interface de surveillance.

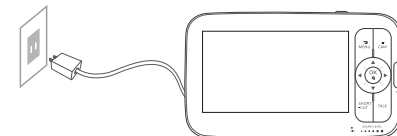

Remarque: Le moniteur prend 4 heures pour être complètement chargé. Et cela dure environ 4 à 5 heures.



RÉGLAGE DE LA CAMÉRA

A remarquer:

La caméra et le moniteur ont été déjà appariés. Cette fonction consiste à rajouter de nouvelles caméras sur le moniteur.

1. Ajouter des caméras

Étape 1:

1. Appuyez sur  pour accéder à la page du menu.
2. Choisissez  et appuyez sur le bouton OK.



Étape 2:

1. Sélectionnez  puis appuyez sur le bouton OK.

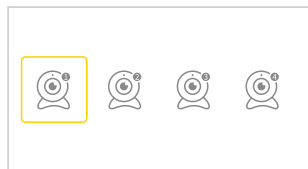

Étape 3:

1. Sélectionnez  et appuyez sur le bouton OK. Caméra n'est pas connectée s'affiche.
2. Appuyez sur le bouton OK pour commencer l'appariement.

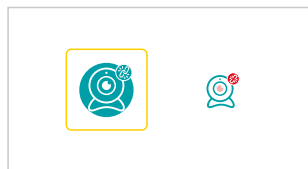

Étape 4:

1. Appuyez sur le bouton  de l'arrière de la caméra.
2. Puis Connexion OK s'affiche.

Remarque: Quatre caméras au maximum peuvent être connectées à un moniteur.

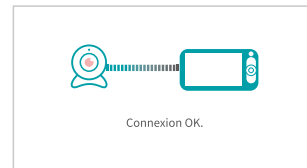

2. Supprimer les caméras

Étape 1:

1. Appuyez sur le bouton menu. Choisissez  et appuyez sur OK.



2. Sélectionnez la caméra à supprimer et appuyez sur OK.

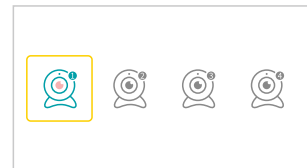

Étape 2:

1. Sélectionnez l'icône de caméra. Appuyez sur OK DEUX fois.

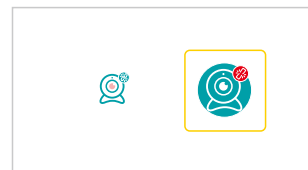

2. Effacement est OK s'affiche. Votre caméra a été supprimée.

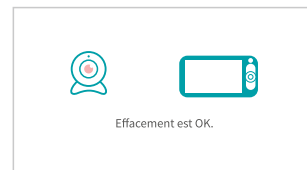



DÉTECTION SONORE

Explication:

Il existe quatre options de détection du son, à savoir AEERT, BAS (80dB), DEFAULT (70 dB) et HAUT (65 dB). ARRET signifie que vous éteignez la fonction; BAS signifie que le son peut être détecté s'il atteint 80dB, et ainsi de suite pour DEFAULT et HAUT.

Etape 1:

1. Appuyez sur  pour accéder à la page de menu. Choisissez  et appuyez sur OK.
2. Sélectionnez l'option vous voulez. Appuyez sur OK.

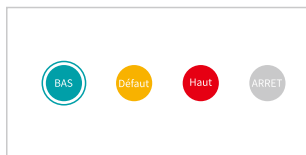

ALARME DE TEMPÉRATURE

Explication:

Cette fonction permet d'envoyer des alarmes si la température est trop basse (inférieure à 15°C / 59°F) ou trop élevée (supérieure à 29°C/84°F).

Etape 1:

1. Appuyez sur  pour accéder à la page de menu. Choisissez  et appuyez sur OK.
2. Sélectionnez et confirmez l'unité souhaitée. MARCHE / ARRET signe démarrer / fermer l'alarme.

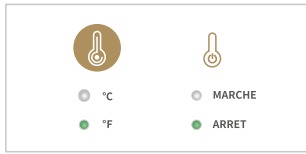



Remarque: En appuyant sur n'importe quel bouton du moniteur, la détection sonore / de température peut être temporairement désactivée.

LANGUE

Explication:

L'appareil comporte 8 genres de langues. Vous pouvez donc choisir votre propre langue ici.

Etape 1:

1. Appuyez sur  pour accéder à la page de menu. Choisissez  et appuyez sur OK.
2. Sélectionnez la langue et appuyez sur OK pour confirmer.

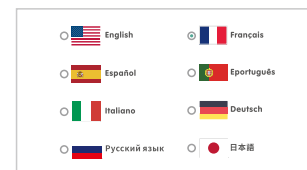



BERCEUSE

Explication:

Cette fonction a pour but de réconforter votre bébé en cas de besoin.

Etape 1:

1. Appuyez sur  pour accéder à la page de menu. Choisissez  et appuyez sur OK.
2. Sélectionnez la berceuse que vous désirez. Sélectionnez TOUT pour démarrer toutes les berceuses.

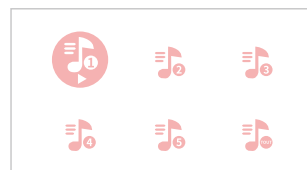



MODE VEILLE

Explication:

Cette fonction permet de prolonger la durée d'exécution de votre moniteur en éteignant l'écran.

Étape 1:

1. Appuyez sur  pour accéder à la page de menu.
Choisissezz  et appuyez sur **OK**.

2. Sélectionnez le temps que vous désirez
Sélectionnez **OFF** pour arrêter la mode veille.

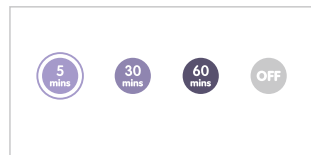
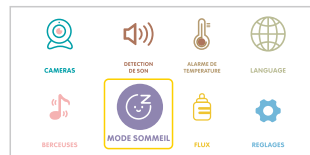



Remarque: L'écran s'allumera automatiquement s'il y a une alarme sonore ou une alarme de température.

ALIMENTATION

Explication:

Cette fonction a pour objet de vous rappeler de nourrir votre bébé. « Fermer » signifie éteindre la fonction. « 2,5 heures » signifie le rappel une fois toutes les 2,5 heures et ainsi de suite.

Étape 1:

1. Appuyez sur  pour accéder à la page du menu.
Vérifiez  et appuyez **OK**.

2. Choisissez le temps.
Sélectionnez **ARRET** pour désactiver la fonctionnalité de rappel d'alimentation.

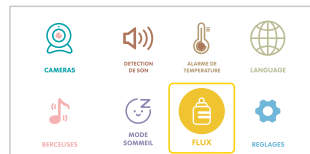



RÉGLAGES

Explication:

Cette fonction permet de définir la date / heure, d'activer / désactiver l'OSD, de restaurer les paramètres d'usine et de fournir des informations de support technique.

Date/Temps:

1. Appuyez sur  pour accéder à la page de menu.
Choisissezz  et appuyez sur **OK**.

2. Sélectionnez **Date / Heures**
Appuyez sur **OK** pour entrer l'interface.

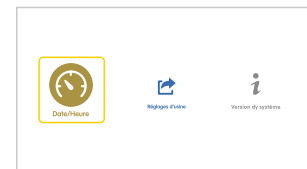

3. Appuyez sur **OK** pour démarrer / terminer la configuration.
Le représentant de  commence le réglage,
4.  est synonyme de réglage final.

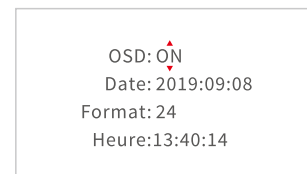
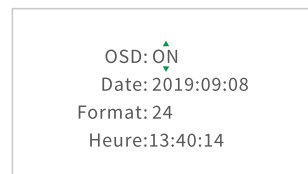

Note:

* Appuyez sur les boutons **Haut / Bas / Gauche / Droite** pour sélectionner, puis appuyez sur le bouton **OK** pour confirmer.

* Si l'OSD est activé, la date et l'heure seront affichées sur la barre d'état du moniteur. Sinon, il ne sera pas affiché.

Restaurer les réglages d'usine:

1. Sélectionnez et appuyez 

Appuyez sur **OK** pour entrer dans l'interface.

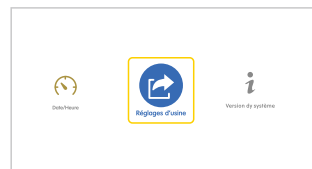

2. Confirmez l'option **OUI**, restaurez les paramètres

d'usine. Appuyez  ou confirmez **NON** pour quitter.



1. Choisissez .

Appuyez sur **OK** pour entrer dans l'interface.

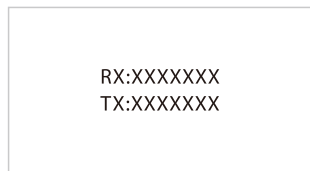
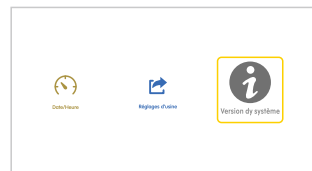

EXPLICATION DES ICÔNES

1. Icônes de la barre d'état

 : Aucune connexion de signal

 : Force du signal

 : Boucle vidéo en direct

 : Berceuses activées

 : Mode veille activé

27°C : Température ambiante actuelle

 : Niveau de batterie

 : Détection sonore activée

 : Alarme de température activée

 : Rappel d'alimentation activé

2. Icônes de notifications



 : Aucune caméra connectée

 : Alarme sonore

 : Alarme de température

 : Notification d'alimentation

Note:

Vous pouvez activer la fonction boucle de vidéo en direct en cliquant sur le bouton  jusqu'à quand tu vois  dans la barre d'état. Lorsque la fonction boucle de vidéo en direct est démarrée, la caméra connectée est automatiquement commutée toutes les 10 secondes. En cas de la détection sonore / de température, la fonction de commutation de caméra est temporairement suspendue.

DIMENSION

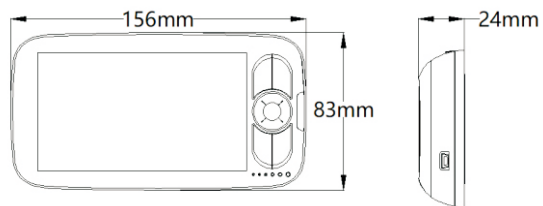

SPÉCIFICATION

Caméra sans fil

Capteur d'image	CMOS H62 1/4 de pouce
Résolution de la caméra	1280*720
Champ d'angle de vision	70° (test horizontal)
Vision nocturne	> 5(IR OFF)/ < 0(IR ON)
Gamme IR	5 mètres
Résolution vidéo	1280 x 720P/25fps
Taux de code vidéo	32kbps-8Mbps
Compression audio	PCM
Transmission audio	Interphone vocal bidirectionnel (Demi-duplex)
Sensibilité Sonore	-47dBm
Mode d'alarme	Détection de la voix
Manière de transmission sans fil	2.4GHz FHSS
Portée de transmission	500 pieds dans une zone résidentielle
	700-900ft en zone ouverte

Interface	Prise de courant continu
	Bouton de réglage
Source de courant	5V, 1.5A
Courant de travail	400(max)
Plage d'alarme de température	590-840°F/15-29°C
Plage d'alarme sonore	≥ 60 dB
Monitor	
Afficher la taille de l'écran	5 pouces
Description de l'écran d'affichage	Écran haute définition, bonne qualité d'image
Résolution	1280*720
Entrée vidéo	Soutenir un canal
Entrée audio	Microphone intégré
	1 interface d'alimentation CC
Interface	1 interrupteur
	1 bouton de menu
	1 touches fléchées gauche et droite
	1 bouton de confirmation
	1 touche de raccourci
	1 touche d'interphone
	1 bouton écran divisé
Source de courant	5V, 1.5A
courant de travail	500(max)
Batterie au lithium intégrée	2000mAh
Taille	156x83x24(mm)
Poids	256g
Général	
Plage de température de stockage	-20° ~ +60°
Opération Humidité	15%~85%

FAQ

Q1. Pourquoi n'ai-je pas réussi à connecter la caméra au moniteur?

- * Assurez-vous de brancher fermement l'adaptateur d'alimentation sur la caméra et sur la prise.
- * Assurez-vous que la caméra et le moniteur se trouvent dans la distance effective.

Q2. Pourquoi la vidéo en direct est-elle si floue?

- * Assurez-vous qu'il n'y a pas d'obstacle sur la lentille ou devant la caméra.

Q3. Pourquoi le moniteur a-t-il fait du bruit?

- * La caméra et le moniteur sont peut-être trop proches. Mettez-les plus éloignés.

Q4. Puis-je entendre mon bébé lorsque j'éteins l'écran?

- * Oui. Vous devez activer la détection du son pour que l'écran se réactive et déclenche une alarme sonore si un son fort est détecté.

Q5. Pourquoi la photo est-elle en noir et blanc?

- * Le mode de vision nocturne est activé si la caméra fonctionne dans un environnement sombre (luminosité ≤ 5 lux).

Q6. Combien de temps le moniteur restera-t-il en veille avec l'écran allumé?

- * Le moniteur peut durer environ 5 heures et la durée d'endurance varie en fonction de la luminosité.

Si vous rencontrez un problème lors de l'utilisation de notre moniteur pour bébé, n'hésitez pas à nous contacter via notre messagerie électronique. Nous sommes extrêmement disposés à résoudre tous les problèmes que vous rencontrez.

Adresse électronique du support: service@cooau.net

→ ITALIANO

ATTENZIONE

Un uso improprio dei prodotti può comportare rischi per la sicurezza. Pertanto, si raccomanda vivamente di leggere le seguenti istruzioni prima di utilizzare il prodotto.

1. Tenere i cavi fuori dalla portata dei bambini per evitare lo strangolamento (3 piedi / 1 metro di distanza).
2. Per evitare cortocircuiti, collocare il prodotto o i prodotti in un luogo asciutto.
3. Utilizzare SOLO gli adattatori CA forniti da noi. L'uso di cavi di ricarica non autorizzati e adattatori CA può causare surriscaldamento e persino un'esplosione.
4. Scollegare gli adattatori CA se non in uso.
5. Controlla regolarmente le attività del tuo bambino, poiché questo prodotto non è stato progettato per la supervisione, ma per aiutare la supervisione.

CONTENUTO DELLA CONFEZIONE

Monitor	
Camera	
Adattatore di alimentazione CA x2	
Kit di montaggio	
Staffa per videocamera	
Cavo di alimentazione Micro-USB x2	
Manuale utente	

CAMERA

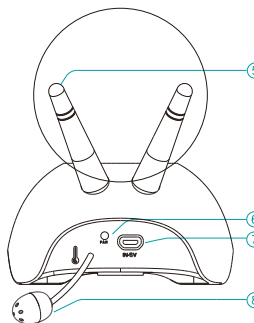
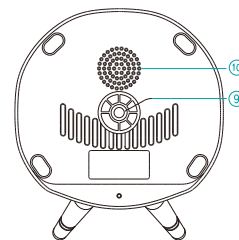
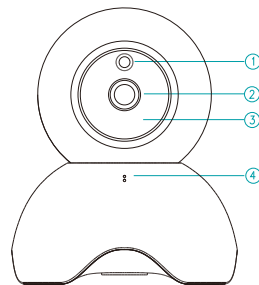
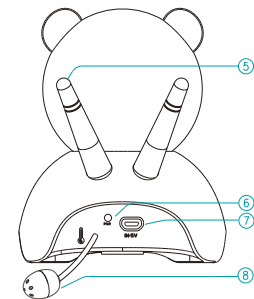
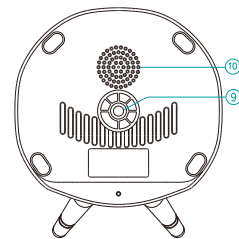
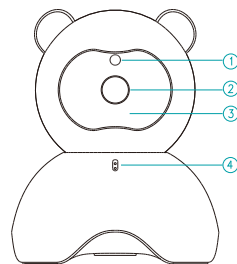

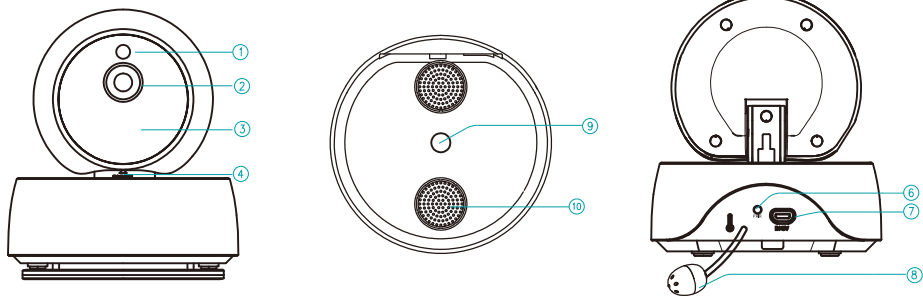
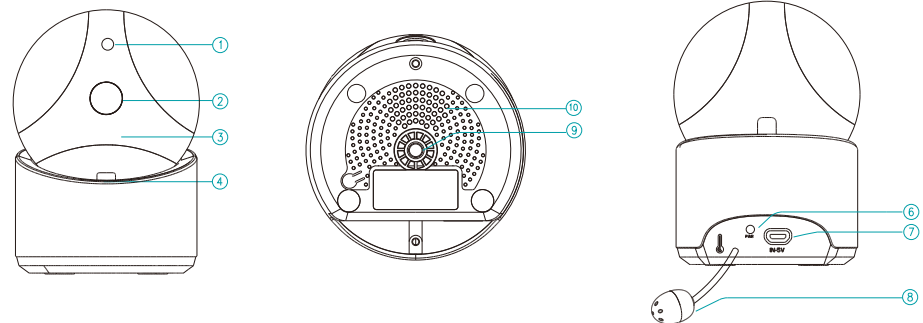

1. Sensore di Visione Notturna
2. Obiettivo della Camera
3. LED IR
4. Microfono

5. Antenna
6. Pulsante di Accoppiamento
7. Ingresso in Corrente
8. Sensore di Temperatura

9. Foro di Montaggio
10. Altoparlante

MONITOR

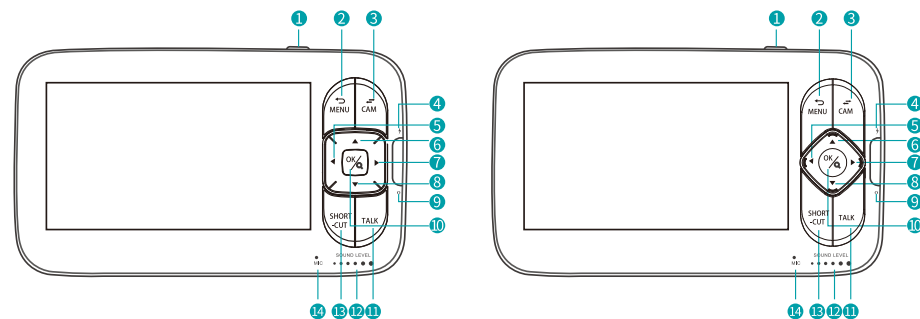
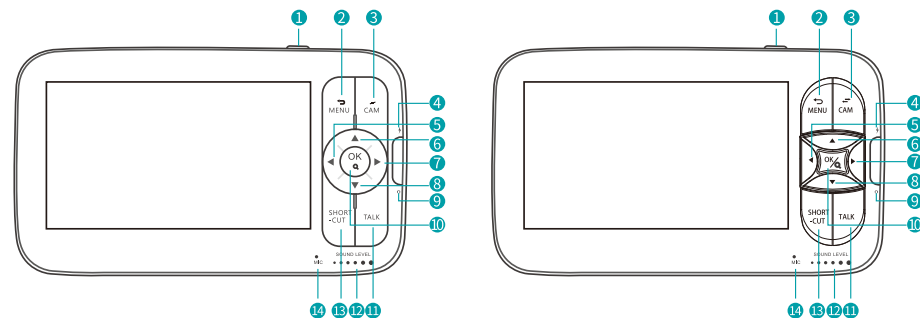

1. **Pulsante On/Off:** premere a lungo per accendere/spegnere il monitor; premere brevemente per accendere/spegnere il display.
2. **Menu/In dietro:** Premere per entrare nella pagina del menu o premere il pulsante Indietro.
3. **Camera Switch:** Cambia videocamera se sei collegato a 2 o più videocamere.
4. **Indicatore di carica:** Emette una luce gialla mentre il monitor è in carica.
5. **A sinistra:** Premere per spostare la fotocamera a sinistra o per cambiare la selezione a sinistra.
6. **Sopra:** Premere per inclinare la fotocamera verso l'alto o per modificare la selezione.
7. **Destra:** Premere per spostare la fotocamera a destra o per modificare la selezione a destra.
8. **In basso:** Premere per inclinare la fotocamera verso il basso o per cambiare la selezione verso il basso.
9. **Indicatore di alimentazione:** La luce verde si accende se è collegata all'elettricità.
10. **Zoom/OK:** Premere per ingrandire o rimpicciolire o per confermare la selezione.
11. **Parlare:** Premere per parlare con il tuo bambino nell'immagine del monitor.
12. **LED del livello sonoro:** Il livello basso/alto mostra il suono basso/alto rilevato dalla telecamera.
13. **Volume/luminosità:** Premere per regolare il volume o la luminosità del monitor nell'immagine del monitor.
14. **Microfono**

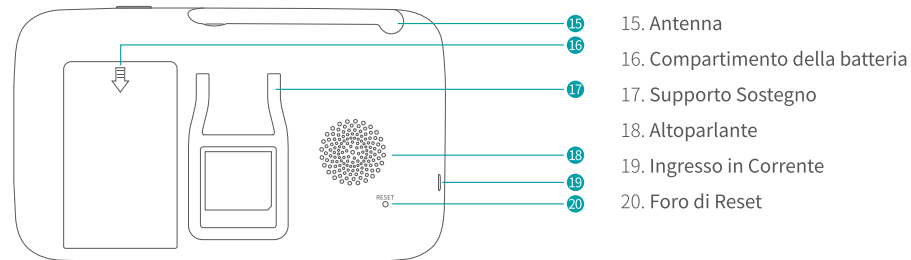

Nota:

1. Premendo il tasto **RESET** con un pin, il monitor verrà automaticamente forzato all'arresto.
2. Non aprire il vano batteria senza la guida ufficiale

CARICA

Passo 1:

1. Collegare la fotocamera all'alimentazione CA adattatore.
2. Inserire l'adattatore CA in una presa a muro.

Nota: Allontanare la fotocamera dal bambino (minimo 3 piedi/1m).

Passo 2:

1. Collegare il monitor all'adattatore CA.
2. Inserire l'adattatore CA in una presa a muro.
3. Premere a lungo il pulsante di accensione per accendere il monitor, è quindi possibile vedere l'interfaccia di monitoraggio.

Nota: Il monitor impiega 4 ore per caricarsi completamente; dura da 4 a 5 ore.

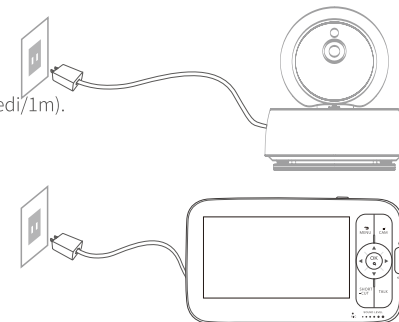



CONFIGURAZIONE DELLA TELECAMERA

Attenzione:

La camera e il monitor sono ora accoppiati. Questa funzione consente di aggiungere nuove camere al monitor.

1. Aggiungere altre Camere

Passo 1:

1. Premere  per accedere alla pagina del menu.
2. Scegliere  e premere il pulsante OK.



Passo 2:

1. Selezionare  e quindi premere il pulsante OK.

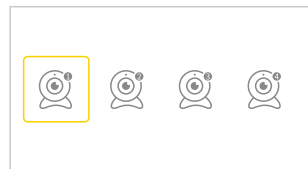

Passo 3:

1. Selezionare  e fare clic su OK.
Verificare che **La fotocamera non è accoppiata.**
2. Premere il pulsante OK per avviare l'accoppiamento.

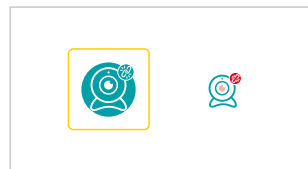

Passo 4:

1. Fare clic sul pulsante  sul retro della camera.
2. Poi vedi il messaggio L'accoppiamento è OK.

Nota: È possibile collegare fino a quattro camere a un monitor.



2. Cancellare Camere

Passo 1:

1. Premere per accedere alla pagina del menu.
Selezionare  e premere OK.



2. Selezionare la telecamera di cui hai bisogno.
Premere OK.

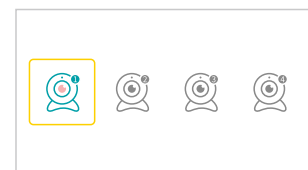

Passo 2:

1. Selezionare l'icona della camera a destra.
Premere **OK DUE VOLTE.**

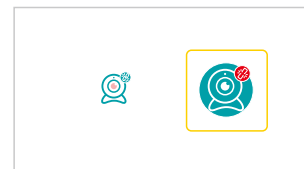

2. Vedere **Soppresso.**
La camera verrà cancellata.

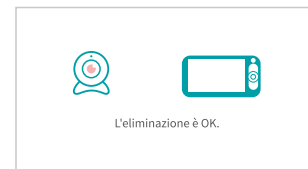



RICONOSCEZZA DEL SUONO

Spiegazione:

Ci sono quattro opzioni di rilevamento del suono: OFF, LOW (80dB), DEFAULT (70dB) e HIGH (65dB).

OFF significa che la funzione è disattivata; LOW significa che il suono può essere rilevato se raggiunge i 80dB, e così via per DEFAULT e HIGH.

Passo 1:

1. Premere  per accedere alla pagina del menu.
Selezionare  e premere OK.



2. Selezionare l'opzione desiderata.
Premere OK.





ALLARME TEMPERATURA

Spiegazione:

Questa funzione consente di inviare allarmi se la temperatura è troppo bassa (< 15°C/59°F) o troppo alta (> 29°C/84°F).

Passo 1:

1. Premere  per accedere alla pagina del menu.
Selezionare  e premere OK.



2. Selezionare e confermare l'unità desiderata.
ON/OFF significa aprire/chiedere l'allarme.

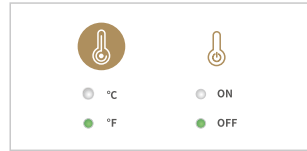



Nota: L'allarme suono/temperatura può essere temporaneamente spento premendo un qualsiasi bottone sul monitor.

LINGUA

Spiegazione:

Ci sono otto lingue integrate nel nostro dispositivo, potete scegliere qui la vostra lingua.

Passo 1:

1. Premere  per accedere alla pagina del menu.
Selezionare  e premere OK.



2. Selezionare la lingua e premere OK per confermare.

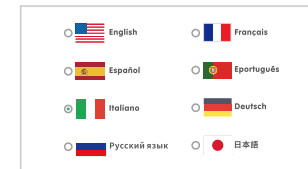



NINNANANNE

Spiegazione:

Questa funzione è di confortare il vostro bambino quando necessario.

Passo 1:

1. Premere  per accedere alla pagina del menu.
Selezionare  e premere OK.



2. Selezionare la ninnananna desiderata.
Selezionare **TUTTO** per riprodurre la ninnananna in un loop.

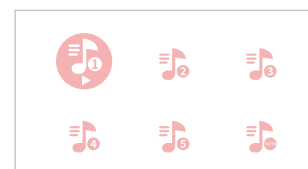

MODALITÀ SLEEP

Spiegazione:

Questa funzione consente di prolungare il tempo di funzionamento del monitor spegnendo il display.

Passo 1:

1. Premere  per accedere alla pagina del menu. selezionare  e premere OK.
2. Selezionare l'ora desiderata. Selezionare OFF per disattivare la funzione riposo.

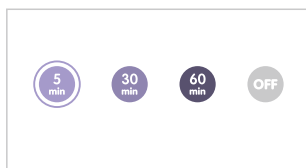

Nota: Il display si illumina automaticamente in presenza di un allarme acustico o di un allarme di temperatura.

POTENZA

Spiegazione:

Questa funzione serve a ricordarvi di dare da mangiare al vostro bambino. OFF significa che la funzione è disattivata; 2,5 ore significa che ogni 2,5 ore e così via per le altre opzioni.

Passo 1:

1. Premere  per accedere alla pagina del menu. selezionare  e premere OK.
2. Selezionare l'ora desiderata. Selezionare OFF per disattivare il promemoria di alimentazione.





AGGIUSTAMENTI



Spiegazione:

Questa funzione serve per impostare la data/ora, attivare/disattivare l'OSD, ripristinare le impostazioni di fabbrica e fornire informazioni di supporto.

Data/ora:

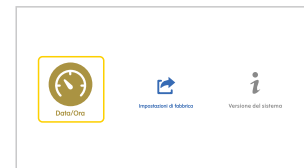
1. Premere  per accedere alla pagina del menu. Selezionare  e premere OK.
2. Selezionare **Data/ora**. Premere OK per accedere all'interfaccia.



3. Premere OK per avviare/finire la configurazione.  è l'inizializzazione dell'impostazione.
4.  significa terminare l'impostazione.

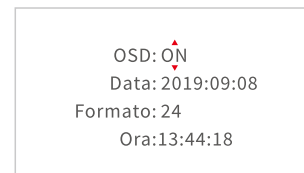
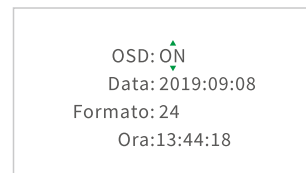

Nota:

- * Premere **Su/Giù/Sinistra/Destra** per selezionare e premere il pulsante **OK** per confermare.
- * Se l'**OSD è abilitato**, la data e l'ora vengono visualizzate nella barra di stato del monitor, altrimenti non vengono visualizzate.

Ristabilire le impostazioni di fabbrica:

1. Selezionare e confermare 

Premere **OK** per accedere all'interfaccia.



2. Modulo **SI** per riavviare.

Premere **MENU** o **NO** per uscire.

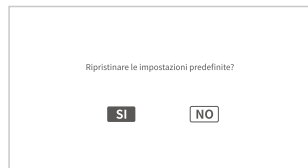



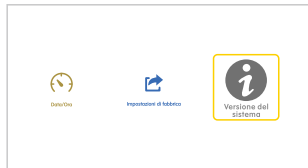





1. Selezionare **i**.







SPIEGAZIONE DI ICONE



1. Icone della barra di stato

-  : Nessuna connessione di segnale
-  : Potenza del segnale
-  : Loop video in diretta
-  : Ninnenanne attivate
-  : Modalità Sleep attivata
- 27°C : Temperatura ambiente attuale
-  : Livello della batteria
-  : Rilevamento del suono attivato
-  : Allarme temperatura abilitato
-  : Promemoria di accensione

2. Icone di notifica

-  : Nessuna camera collegata
-  : Allarme sonoro
-  : Allarme temperatura
-  : Notifica dei mangimi

Spiegazione:

È possibile aprire la funzione Live-Video-Loop tramite una breve pressione sul pulsante  fino a quando non viene visualizzato  sulla barra di stato. Quando la funzione Live-Video-Loop è attiva, le telecamere collegate cambieranno automaticamente ogni 10 secondi. E se c'è un allarme di suono o temperatura, la funzione di interruttore della fotocamera si fermerà temporaneamente.

DIMENSIONE

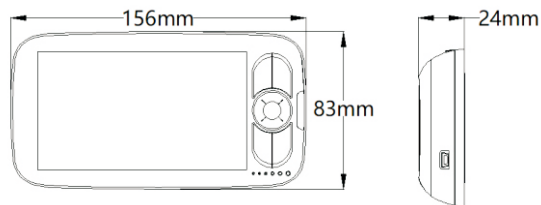

SPECIFICHE

Telecamera senza fili

Sensore d'immagine	1/4-inch CMOS H62
Risoluzione della fotocamera	1280*720
Campo dell'angolo di visione	70°(Horizontal test)
Visione notturna	>5(IR OFF)/<0(IR ON)
Gamma IR	5 metri
Risoluzione video	1280 x 720P/25fps
Velocità codice video	32kbps-8Mbps
Compressione audio	PCM
Trasmissione audio	Citofono vocale a due voci (Half Duplex)
Sensibilità al suono	-47dBm
Modalità sveglia	Rilevazione vocale
Modo di trasmissione wireless	2.4GHz FHSS
Gamma di transmission	500 piedi in zona residenziale 700-900 piedi in area aperta

Interfaccia	Pres a DC Pulsante Imposta
Alimentazione elettrica	5V, 1.5A
Corrente di lavoro	400(max)
Corrente di lavoro	590-840°F/15-29°C
Gamma di allarmi sonori	≧60 dB
Tenere sotto controllo	
Visualizza le dimensioni dello schermo	5 pollici
Visualizza la descrizione dello schermo	Schermo ad alta definizione, buona qualità dell'immagine
Risoluzione	1280*720
Ingresso video	Supporta un canale
Ingresso audio	Microfono incorporato
Interfaccia	1 interfaccia di alimentazione CC
	1 interruttore di alimentazione
	1 pulsante menu
	1 tasti freccia sinistra e destra
	1 pulsante di conferma
	1 tasto di scelta rapida
Alimentazione elettrica	5V, 1.5A
	corrente di lavoro
Batteria al litio integrata	2000mAh
Taglia	156x83x24(mm)
Peso	256g
Generale	
Gamma di temperature di stoccaggio	-20° ~ +60°
Umidità operativa	15%~85%

DOMANDE FREQUENTI

Q1. Perché la camera non era collegata al monitor?

- * Assicurarsi di collegare saldamente l'adattatore di alimentazione alla camera e alla spina.
- * Assicurarsi che la camera e il monitor si trovino entro la distanza effettiva.

Q2. Perché il video in diretta è così sfocato?

- * Assicurarsi che non ci siano ostacoli nell'obiettivo o davanti alla camera.

Q3. Perché il monitor fa rumore?

- * La camera e il monitor potrebbero essere troppo vicini. Separateli ulteriormente.

Q4. Posso sentire il mio bambino quando spengo lo schermo?

- * Sì, è necessario attivare la funzione di **rilevamento del suono**, che attiverà lo schermo e emetterà un allarme acustico se viene rilevato un suono forte.

Q5. Perché l'immagine è in bianco e nero?

- * La modalità visione notturna si attiva se la camera opera in un ambiente buio (Luminosità ≤ 5 Lux).

Q6. Per quanto tempo il monitor rimane in standby con lo schermo acceso?

- * Il monitor può durare circa 5 ore e il tempo di resistenza varia a seconda della luminosità.

Se riscontri problemi durante l'utilizzo del nostro baby monitor, non esitare a contattarci tramite la nostra casella di posta elettronica dell'assistenza. Siamo estremamente disposti a risolvere tutti i problemi che incontri.

Indirizzo e-mail di supporto: service@cooau.net

→ **ESPAÑOL**

ADVERTENCIA

El uso incorrecto de los productos puede conllevar riesgos para la seguridad. Por lo tanto, le recomendamos encarecidamente que lea las siguientes instrucciones antes de utilizar su producto.

1. Mantenga el (los) cable(s) fuera del alcance de los niños para evitar casos de estrangulamiento (3 pies/ 1 metro de distancia).
2. Para evitar un cortocircuito, coloque el producto(s) en un lugar seco.
3. Utilice ÚNICAMENTE los adaptadores de CA suministrados por nosotros. El uso de cables de carga y adaptadores de CA no autorizados puede provocar un sobrecalentamiento e incluso una explosión.
4. Desconecte el(los) adaptador(es) de CA si no lo utiliza(n).
5. Compruebe regularmente las actividades de su bebé, ya que este producto no está diseñado para la supervisión, sino para ayudar a su supervisión.

CONTENIDO DEL PAQUETE

Monitor		or		or		or	
Cámara		or		or		or	
Adaptador de alimentación de CA x2		Kit de montaje		or		Cable de alimentación Micro-USB x2	

CÁMARA

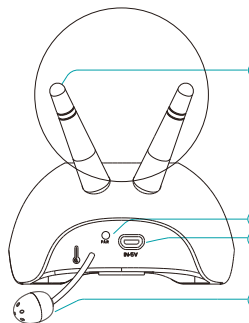
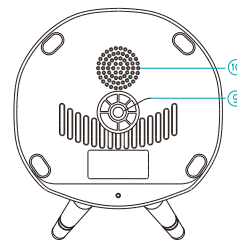
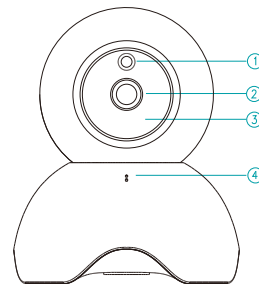
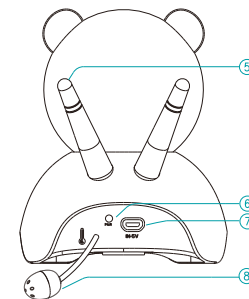
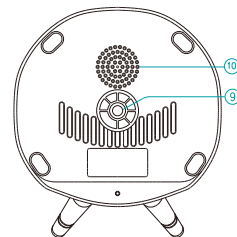
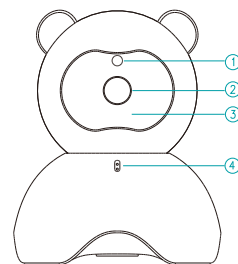

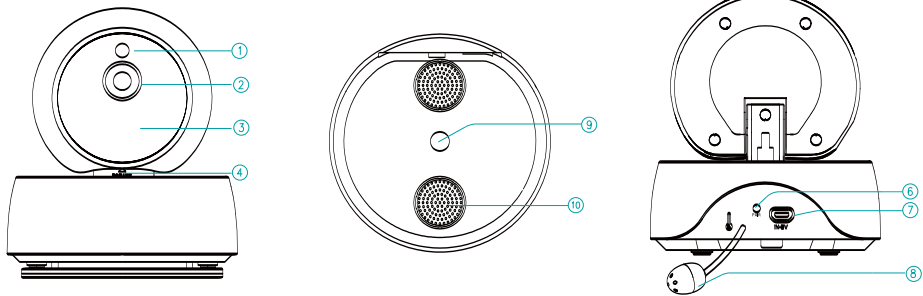
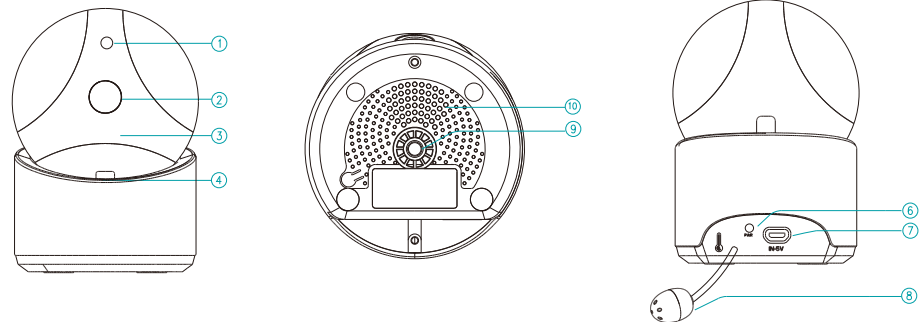

1. Sensor de Visión Nocturna
2. Lente de la Cámara
3. LED IR
4. Micrófono

5. Antena
6. Botón de Emparejamiento
7. Entrada de Corriente
8. Sensor de Temperatura

9. Orificio de Montaje
10. Altavoz

MONITOR

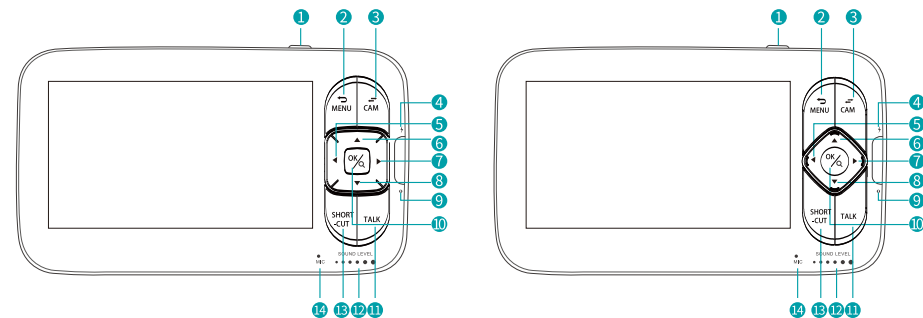
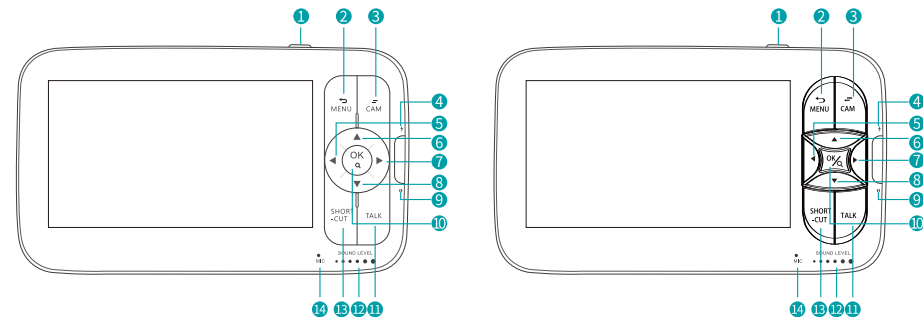

1. **PBotón de encendido/apagado:** Pulsación larga para encender/apagar el monitor; pulsación corta para encender/apagar la pantalla.
2. **Menú/Atrás:** Presione para entrar a la página del menú o presione el botón Atrás.
3. **Interruptor de cámara:** Cambie de cámara si está conectado con 2 o más cámaras.
4. **Indicador de carga:** Emite luz amarilla mientras se está cargando el monitor.
5. **Izquierda:** Púselo para desplazar la cámara hacia la izquierda o para cambiar su selección hacia la izquierda.
6. **Arriba:** Pulse para inclinar la cámara hacia arriba o para cambiar su selección hacia arriba.
7. **Derecha:** Púselo para desplazar la cámara hacia la derecha o para cambiar su selección hacia la derecha.
8. **Abajo:** Pulse para inclinar la cámara hacia abajo o para cambiar su selección hacia abajo.
9. **Indicador de Encendido:** La luz verde se enciende si está conectada a la electricidad.
10. **Zoom/OK:** Pulse para acercar o alejar el zoom o para confirmar su selección.
11. **Hablar:** Oprima para hablar con su bebé en la imagen de monitorización.
12. **LED de nivel de sonido:** El nivel bajo/alto muestra el sonido bajo/alto detectado por la cámara.
13. **Volumen/Brillo:** Pulse para ajustar el volumen o el brillo del monitor en la imagen de monitorización.
14. **Micrófono**

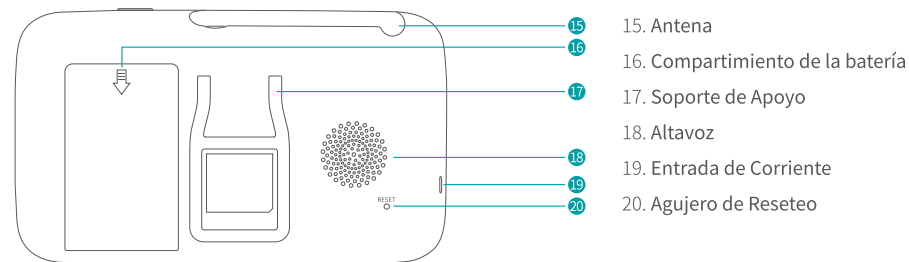

Nota:

1. Si pulsa **RESET** con un pin, el monitor se apagará de forma forzada.
2. No abra el compartimento de la batería sin la autorización oficial.

CARGA

Paso 1:

1. Conecte la cámara al AC adaptador.
2. Enchufe el adaptador de CA en un enchufe.

Nota: Aleje la cámara de su bebé (3 pies/1m como mínimo).

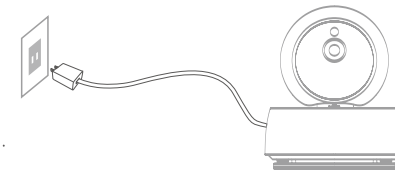

Paso 2:

1. Conecte el monitor al adaptador de CA.
2. Enchufe el adaptador de CA en un enchufe.
3. Pulse el botón de encendido para abrir el monitor y podrá ver la interfaz de monitorización.

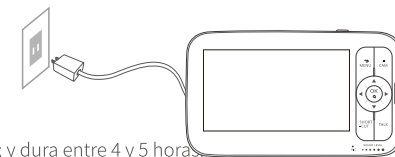

Nota: El monitor tarda 4 horas en cargarse completamente; y dura entre 4 y 5 horas.



CONFIGURACIÓN DE LA CÁMARA

Aviso:

La cámara y el monitor ya están emparejados. Esta función es para añadir nuevas cámaras al monitor.

1. Añadir Cámaras

Paso 1:

1. Presione  para entrar a la página del menú.
2. Elija  y presione el botón OK.



Paso 2:

1. Seleccione  y luego presione el botón OK.

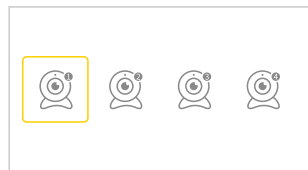

Paso 3:

1. Seleccione  y pulse el botón OK.
Ver que la Cámara NO está emparejada.
2. Presione el botón OK para iniciar el emparejamiento.

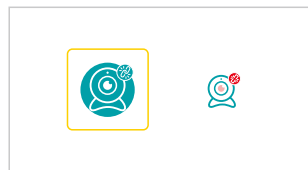

Paso 4:

1. Pulse el botón  en el botón  de la parte trasera de la cámara.
2. Luego vea el mensaje **Emparejamiento correcto**.

Nota: Se pueden conectar como máximo cuatro cámaras a un monitor.



2. Eliminar Cámaras

Paso 1:

1. Pulse para entrar en la página del menú.
Seleccione  y pulse OK.



2. Seleccione la cámara que necesita ser borrada.
Pulse OK.

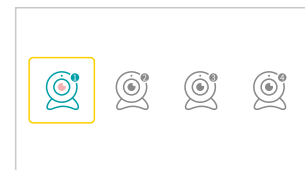

Paso 2:

1. Seleccione el icono de la cámara derecha.
Presione **OK DOS VECES**.

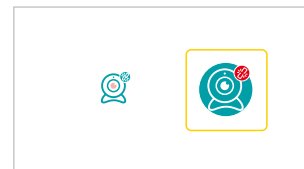

2. Ver **Eliminación correcta**.
Su cámara se eliminará.

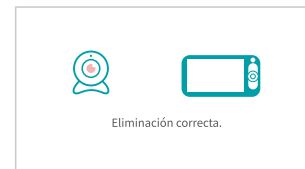

DETECCIÓN DE SONIDO

Explicación:

Hay cuatro opciones de detección de sonido: OFF, BAJO (80dB), POR DEFECTO (70dB) y ALTO (65dB). OFF significa que se apaga la función; BAJO significa que el sonido puede ser detectado si alcanza los 80dB, y así sucesivamente para POR DEFECTO y ALTO.

Paso 1:

1. Presione  para entrar a la página del menú.
Seleccione  y pulse OK.



2. Seleccione la opción que desee.
Pulse OK.

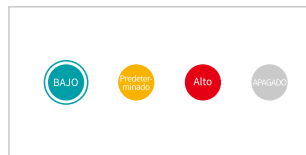



ALARMA DE TEMPERATURA

Explicación:

Esta función es para enviar alarmas si la temperatura es demasiado baja (< 15°C/59°F) o demasiado alta (> 29°C/84°F).

Paso 1:

1. Presione  para entrar a la página del menú.
Seleccione  y pulse OK.



2. Seleccione y confirme la unidad que desee.
ON/OFF significa abrir/cerrar la alarma.

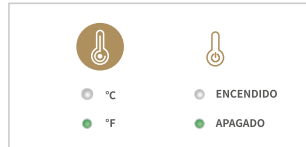

Nota: Una alarma de sonido / temperatura se puede apagar temporalmente pulsando cualquier botón del monitor.

IDIOMA

Explicación:

Hay ocho idiomas incorporados en nuestro dispositivo, puede elegir su idioma aquí.

Paso 1:

1. Presione  para entrar a la página del menú.
Seleccione  y pulse OK.



2. Seleccione su idioma y pulse OK para confirmar.

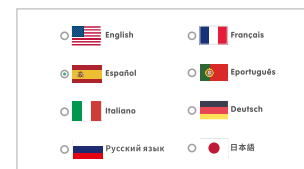



NANAS

Explicación:

Esta función es para consolar a su bebé cuando sea necesario.

Paso 1:

1. Presione  para entrar a la página del menú.
Seleccione  y pulse OK.



2. Seleccione la canción de cuna que quiera.
Seleccione ALL para reproducir la canción de cuna en bucle.

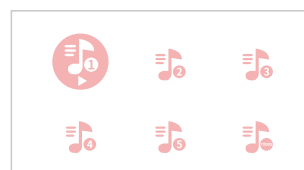



MODO DE SUEÑO

Explicación:

Esta función es para prolongar el tiempo de ejecución de su monitor apagando la pantalla.

Paso 1:

1. Pulse  para entrar en la página del menú. seleccione  y pulse OK.

2. Seleccione la hora que desee. Seleccione OFF para desactivar el modo de reposo.

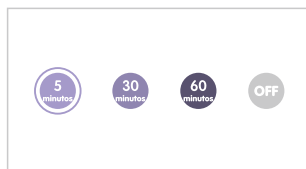



Nota: La pantalla se iluminará automáticamente si hay una alarma sonora o una alarma de temperatura.

ALIMENTACIÓN

Explicación:

Esta función es para recordarle que debe alimentar a su bebé. OFF significa que usted apaga la función; 2.5 horas significa que le recuerda cada 2.5 horas y así sucesivamente para las otras opciones.

Paso 1:

1. Presione  para entrar a la página del menú. seleccione  y pulse OK.

2. Seleccione la hora que desee. Seleccione OFF para desactivar el recordatorio de alimentación.





AJUSTES

Explicación:

Esta función sirve para ajustar la fecha/hora, activar/desactivar el OSD, restaurar los ajustes de fábrica y proporcionar información de asistencia técnica.

Fecha/Hora:

1. Presione  para entrar a la página del menú. Seleccione  y pulse OK.

2. Seleccione Fecha/Hora. Pulse OK para entrar en la interfaz.

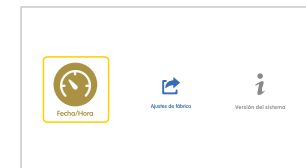

3. Pulse OK para iniciar/finalizar la configuración.  es la inicialización del ajuste.

4.  significa terminar el ajuste.



Nota:

* Pulse **Arriba/Abajo/Izquierda/Derecha** para seleccionar y pulse el botón **OK** para confirmar.

* Si **OSD** está **activado**, la fecha y la hora se mostrarán en la barra de estado del monitor; de lo contrario, no se mostrarán.

Restaurar los ajustes de fábrica:

1. Seleccionar y conformar 

Pulse **OK** para entrar en la interfaz.

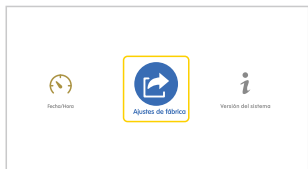

2. Conformar **SI** para reiniciar.

Pulse **MENU** o conforme a **NO** para salir.

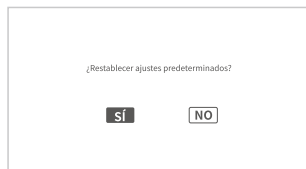

1. Seleccione **i**.

Pulse **OK** para entrar en la interfaz.

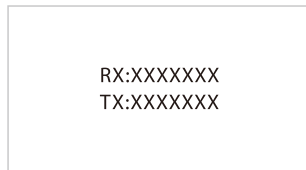
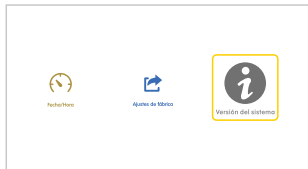

EXPLICACIÓN DE LOS ICONOS

1. Iconos de la barra de estado

 : Sin conexión de señal

 : Intensidad de la señal

 : Bucle de vídeo en directo

 : Canciones de cuna activadas

 : Modo de reposo activado

27°C : Temperatura ambiente actual

 : Nivel de batería

 : Detección de sonido activada

 : Alarma de temperatura habilitada

 : Recordatorio de alimentación activado

2. Iconos de Notificaciones



 : No hay cámara conectada

 : Alarma de sonido

 : Alarma de temperatura

 : Notificación de alimentación

Explicación:

Puede abrir la función Live-Vídeo-Loop pulsando brevemente el botón  hasta que vea  en la barra de estado. Cuando la función de Live Vídeo-Loop está activada, las cámaras conectadas cambiarán automáticamente cada 10 segundos. Y si hay una alarma de sonido / temperatura, la función de intercambio de cámara se detendrá temporalmente.

DIMENSIÓN

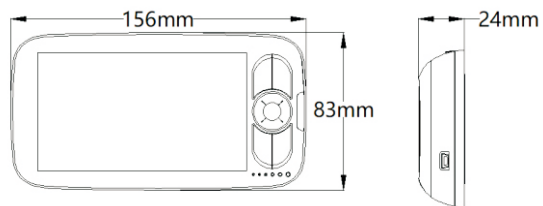

ESPECIFICACIÓN

Cámara inalámbrica

Sensor de imagen	1/4 de pulgada, CMOS H62
Resolución de la cámara	1280*720
Campo de ángulo de visión	70° (prueba horizontal)
Vision nocturna	>5(IR OFF)/<0(IR ON)
Rango IR	5 metros
Resolución de video	1280 x 720P/25fps
Tasa de código de video	32kbps-8Mbps
Compresión de audio	PCM
Transmisión de audio	Intercomunicador de voz bidireccional (Medio duplex)
Sensibilidad al sonido	-47dBm
Modo de alarma	Detección de voz
Manera de transmisión inalámbrica	2.4GHz FHSS
Rango de transmisión	500 pies en zona residencial
	700-900 pies en área abierta

Interfaz	DC Enchufe
	Botón de ajuste
Fuente de alimentación	5V, 1.5A
Corriente de trabajo	400(máximo)
Rango de alarma de temperatura	590-840°F/15-29°C
Rango de alarma sonora	≥ 60 dB
Monitor	
Tamaño de pantalla	5 pulgadas
Descripción de la pantalla de visualización	Pantalla de alta definición, buena calidad de imagen.
Resolución	1280*720
Entrada de video	Admite un canal
Entrada de audio	Micrófono incorporado
Interfaz	1 interfaz de alimentación de CC
	1 interruptor de encendido
	1 botón de menú
	1 teclas de flecha izquierda y derecha
	1 botón de confirmación
	1 tecla de acceso directo
	1 tecla de intercomunicador
1 botón de pantalla dividida	
Fuente de alimentación	5V, 1.5A
corriente de trabajo	500(máximo)
Batería de litio incorporada	2000mAh
tamaño	156x83x24(mm)
Peso	256g
General	
Rango de temperatura de almacenamiento	-20° ~ +60°
Operación Humedad	15%~85%

PREGUNTAS FRECUENTES

Q1. ¿Por qué no se conectó la cámara al monitor?

- * Asegúrese de conectar firmemente el adaptador de corriente a la cámara y al enchufe.
- * Asegúrese de que la cámara y el monitor están dentro de la distancia efectiva.

Q2. ¿Por qué el video en vivo es tan borroso?

- * Asegúrese de que no haya ningún obstáculo en el objetivo o delante de la cámara.

Q3. ¿Por qué hace ruido el monitor?

- * La cámara y el monitor pueden estar demasiado cerca. Sepáralas más.

Q4. ¿Puedo escuchar a mi bebé cuando apago la pantalla?

- * Sí, debe activar la función de detección de sonido, que activará la pantalla y emitirá una alarma sonora si se detecta un sonido fuerte.

Q5. ¿Por qué la imagen es en blanco y negro?

- * El modo de visión nocturna estará activado si la cámara funciona en un entorno oscuro ($\text{Brightness} \leq 5 \text{ Lux}$).

Q6. ¿Cuánto tiempo estará el monitor en espera con la pantalla encendida?

- * El monitor puede durar unas 5 horas, y el tiempo de resistencia varía en función de la luminosidad.

Si tiene algún problema mientras usa nuestro monitor para bebés, no dude en comunicarse con nosotros a través de nuestro buzón de correo electrónico de soporte. Estamos extremadamente dispuestos a resolver todo el problema que encuentre.

Dirección de correo electrónico de soporte: service@cooau.net