



## Instruction Manual

SLE75 / SLE100 / SLE125/  
SLE150 / SLE200 Cassette Fires

**This product is only suitable for well insulated spaces or occasional use.**

To be left with the customer after demonstrating the features of the Solution SLE electric fire.

**The complete installation must be carried out in accordance with current Standards and Local Codes. The instructions in this manual must be followed to ensure safe operation of the appliance. It should be noted that the requirements and this publication may be superseded during the life of the Fireplace - please refer to [www.solutionfires.co.uk](http://www.solutionfires.co.uk) for up-to-date instructions.**



The product complies with the European Safety Standards EN60335-2-30 and the European Standard Electromagnetic Compatibility (EMC) EN55014, EN60555-2 and EN60555-3. These cover the essential requirements of EEC Directives 2006/95/EC and 2004/108/EC

# Contents

Important Safety Advice.....	03
Installation & Operating Instructions.....	05
Installation Requirements.....	05
Unpacking and Testing.....	05
Installation.....	05
Remote Control Operating Instructions.....	10
Powering the Fire.....	10
Heater ON/OFF.....	10
Remote Control Buttons.....	11
Flame Preset.....	11
Volume.....	11
Product Dimensions.....	13
Technical Parameters.....	14
Cleaning.....	15
Thermal Safety Cut-Out.....	15
Light Emitting Diode.....	16
Battery Replacement Remote Control.....	15
Troubleshooting.....	16
Servicing and Maintenance.....	17
Correct Disposal of this Product.....	17
Solution Fires Warranty.....	18
Replaceable Parts.....	19
Wiring Diagram.....	20
<b>Solution Fires App Control Instructions.....</b>	<b>21</b>

# Important Safety Advice

When using electrical appliances, basic precautions should be followed to reduce the risk of fire, electric shock, and injury to persons, including the following:

- **WARNING:** If the appliance is damaged, check immediately with your retailer before installation and operation. The heater must not be used if any part of it is damaged.
- Do not use outdoors.
- **WARNING:** In order to avoid overheating, do not cover the heater.
- The appliance carries the Warning Symbol indicating that it must not be covered or has a do not cover label. Do not cover or obstruct in any way the heat outlet grille located above the window of the appliance. 
- Do not place material or garments over the front of the appliance as this could cause overheating and a fire risk.
- In the event of a fault unplug the heater.
- Unplug the appliance when not required for long periods.
- This appliance can be used by persons if they have been given instruction concerning use of the appliance in a safe way or are supervised and understand the hazards involved.
- This appliance can be used by children aged from 8 years and above and persons with reduced physical, sensory or mental capabilities or lack of experience or knowledge if they have been given instruction or supervision concerning use of the appliance in a safe way and understand the hazards involved.
- Children shall not play with the appliance. Cleaning and user maintenance shall not be carried out by children without adequate supervision.
- Children of less than 3 years should be kept away from the appliance unless continuously supervised.
- Children aged from 3 years and less than 8 years shall only switch on/off the appliance provided that it has been placed or installed in its intended normal operating position and they have been given instruction or supervision concerning use of the appliance in a safe way and understand the hazards involved.
- Children aged from 3 years and less than 8 years shall not plug in, regulate or clean the appliance or perform user maintenance on the appliance.
- If the supply cord is damaged, switch off the mains power at the wall socket immediately.
- **WARNING:** The heater must not be located immediately below, above or in front of a fixed socket outlet or electrical connection box.
- **WARNING:** Do not use this heater in small rooms when they are occupied by persons not capable of leaving the room on their own, unless constant supervision is provided.
- **CAUTION:** In order to avoid a hazard due to inadvertent resetting of the thermal cut-out, this appliance must not be supplied through an external switching device, such as a timer, or connected to a circuit that is regularly switched on and off by the utility.
- **CAUTION:** Some parts of this appliance around the heater grill can become very hot and cause burns. Particular attention has to be given where children and vulnerable people are present.
- The heater must not be positioned or used where it may come into contact with water, for example but not exclusively, in wet rooms, bathrooms, swimming pools, laundries or used to dry clothes.
- Do not use the appliance in rooms with explosive gas (e.g. petrol) or while using inflammable glue or solvent (e.g. when gluing or varnishing parquet floors, PVC etc.)
- Do not insert any objects into the appliance.
- This appliance must be connected to a 220-240VAC 50-60Hz supply.
- If the supply cord is damaged, it must be replaced by the manufacturer, its agent or a similarly qualified person in order to avoid a hazard.

- This appliance is supplied with a power lead complete with a moulded 13 Amp UK three-pin plug to connect into a standard UK socket outlet. This appliance must be earthed. The plug must be easily accessible after siting the appliance. Should a new fuse be required, consult a competent person to establish the reason for the fuse operating. Only once the fault is rectified should a new 13A fuse be inserted into the plug.
- Use only a dry duster or vacuum cleaner with brush attachment to clean the appliance. Never use abrasive cleaners, water, steam cleaners or aerosols on or near the appliance.
- Only control the appliance using the manual operations or the supplied remote control described in this manual. Do not use this heater with a programmer, timer, separate remote control system or any other device that switches the heater on automatically. You may also use the Solution Fires App to control your fire.

**Remote Control Battery Warning:**

Only adults should handle the batteries. Do not allow a child to use the remote control unless the battery cover is securely attached to the battery compartment. All batteries must be disposed of at your local recycling point.

**Box Contents:**

Please check that the following components are included within the box. If anything is missing or damaged, please contact the retailer and do not use the appliance until you have everything.

- Appliance with trailing lead with moulded 13 Amp plug.
- Remote control hand set and batteries.
- Fixing brackets/side plaster beads.
- Instruction Manual.
- Glass Removal Suction Pad(s) - 1 for SLE75 SLE100 and SLE125, 2 for SLE150 and SLE200.
- Magnet Tool

**Installation - Front Glass Removal (Caution - wear suitable gloves when handling glass)**

1. Remove the long front steel cover at the bottom of the front glass screen with the magnet tool provided.

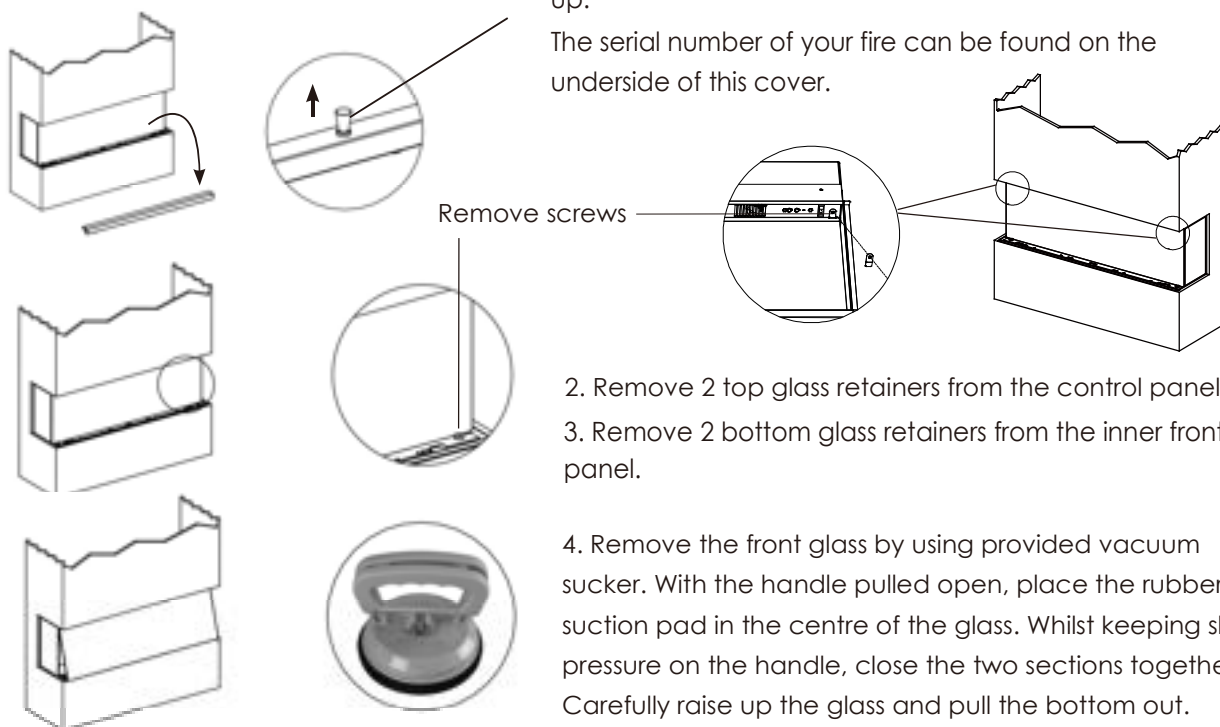

**Magnet tool**

Place the tool to one end of the cover and slowly lift up.

The serial number of your fire can be found on the underside of this cover.

2. Remove 2 top glass retainers from the control panel.
3. Remove 2 bottom glass retainers from the inner front panel.

4. Remove the front glass by using provided vacuum sucker. With the handle pulled open, place the rubber suction pad in the centre of the glass. Whilst keeping slight pressure on the handle, close the two sections together. Carefully raise up the glass and pull the bottom out.

# Installation & Operating Instructions

## Installation Requirements

Before commencing installation of the unit consideration should be given to the following:

1. Read these instructions thoroughly.
2. You will need the suitable tools (e.g. drill and drill bits, screwdrivers, spirit level, tape measure).
3. Select a location that is not prone to moisture.
4. A 13 amp, 240 Volt socket or switched, fused spur capable of accommodating a maximum load of 2050 watts must be available close to the appliance. The socket must be accessible at all times and must not be placed directly behind the unit. Ensure that the circuit and associated breaker are sized for the connected load.
5. This product has been designed to be installed into a plaster board, or existing chimney breast.
6. Please seek advice from a professional, with reference to the structural integrity of the installation site.
7. If the product is to be installed into an open chimney or flue, it is important that the chimney flue is blocked off to prevent any up/down draughts and falling debris which could restrict and alter the airflow to the product.
8. It is also important to ensure that the product has a minimum internal clearance directly above and below the product of 100mm, this is to ensure that the product can circulate the required airflow for the heater unit.
9. The product should never be sealed into an opening with the use of silicones or adhesives as this can also alter the airflow and hinder any further servicing of the product.
10. DO NOT SCREW ANY FIXINGS INTO THE BODY OF THE FIRE TO MOUNT ANY FURNITURE OR OTHER PARTS NOT SUPPLIED WITH THE FIRE.

**Note: Plaster flanges and furniture guides are not for support, ensure all furniture/falsework is independently supported.**

## Installing Product:

### Unpacking & Testing

1. Carefully remove the unit from the packaging and prior to installing the unit, test the unit by plugging the power supply into a conveniently located 13 amp earthed socket.
2. Your product is supplied with one or more wall mounting brackets. (Dependent on Model)
3. Establish the desired finished height from floor level to the bottom of the plaster kit of the product.
4. Fix the wall bracket to the wall ensuring to use the correct hardware fixings (not provided) given the wall construction, plaster board or solid wall.

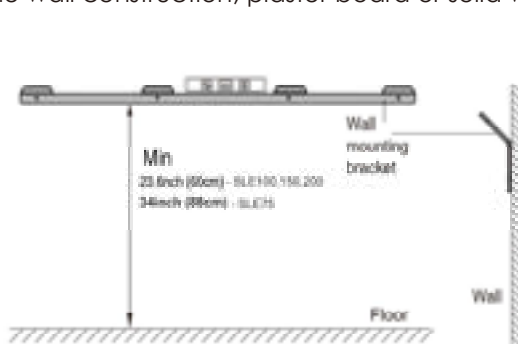

Fig.3

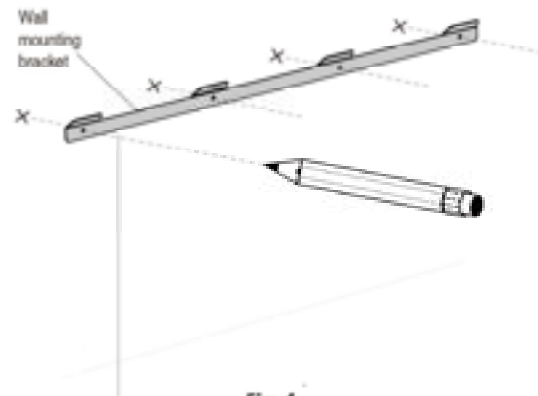

Fig.4

The fire is designed to be permanently fixed to a wall at a suitable height, the wall bracket must be fitted horizontally and the cable routed to the bottom right of the fire. A height of 60cm - SLE100, SLE125, SLE150, SLE200 and 88cm - SLE75 from the floor to the bottom of the bracket is suggested. You will need to calculate the height of the bracket if the fire is being fitted into a suite or purpose-made chimney breast. **See following page for further frame fitting instructions.**

# Installation Instructions

## Installation - Continued

5. Remove the wall brace brackets, then lift and hook the product onto the wall bracket and secure using the wall brace brackets.

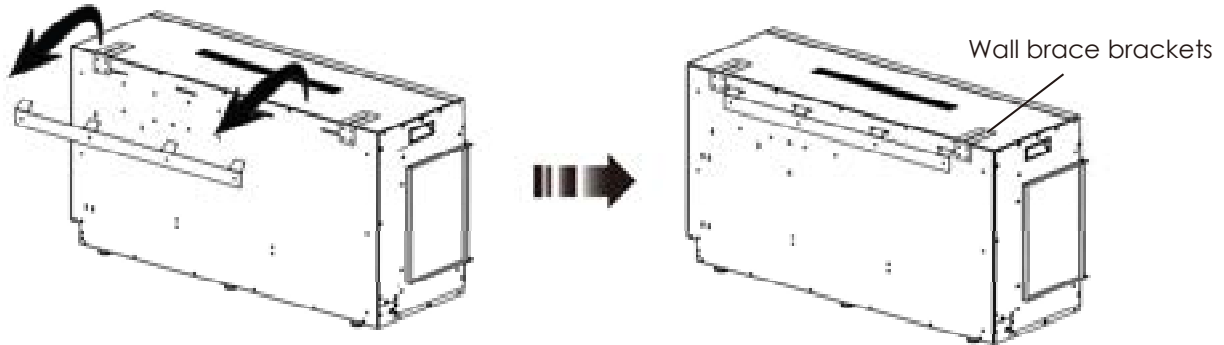

6. Fix the wall brace brackets ready to secure to the wall.

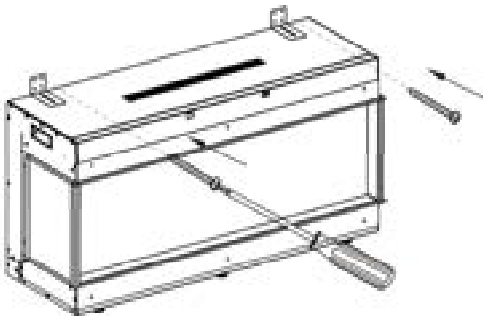

7. Once the product is secured to the wall and connected to the power supply, the false construction such as plaster board wall or chimney breast can be formed around it.

8. The product is also designed to allow a platform to support it. The front feet are adjustable by using a slotted screwdriver (see Fig 1), remove the front metal cover by using the magnet tool (supplied) for this operation. Adjust the rear feet from beneath the fire and fine-tune using the front feet.

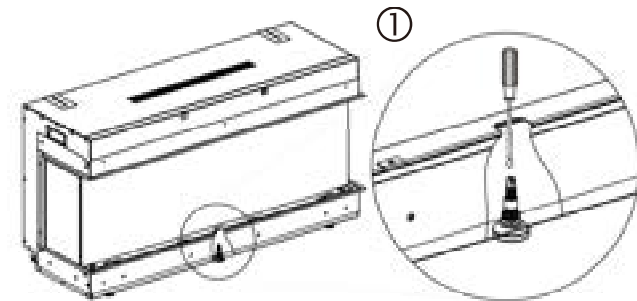

## Scene Lighting Kit

If you are using a scene lighting kit ensure the kit is plugged into the external power socket on the fire before building the appliance into any fireplace or suite (Fig 2). The maximum connected load is 12V DC, 5A and only genuine Solution Fires parts may be connected. The light kit provided by the manufacturer has 4m of LED strip lights which is the maximum allowable length.

**Note:** Ensure all power is off during the installation process.

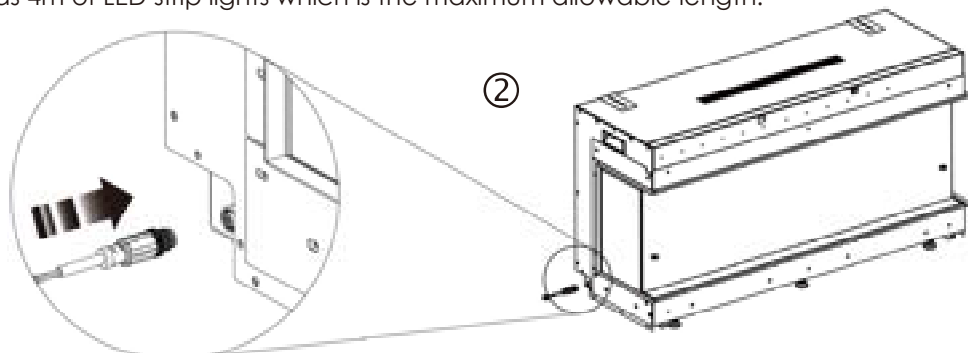

# Installation Instructions

## Installation - Continued

The SLE Cassette Fires are designed for four different installation types.

### Installation - Option 1 - Front View

#### Option 1

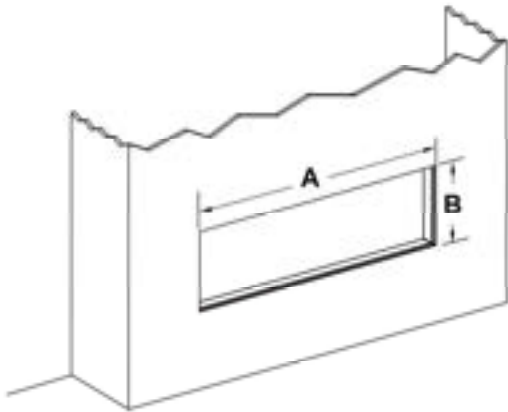
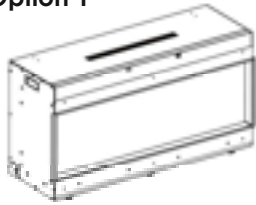

#### NOTE:

No screws or fixings for the furniture surrounding your fire may be fixed to the fire. This will invalidate your warranty.

Remove the furniture guides and recycle when installing the fire as shown in Options 1-4

Model	A	B	C	D	E	F	G
SLE75	750mm	580mm	808mm	226mm	334mm	118mm	110mm
SLE100	1000mm	305mm	533mm	226mm	334mm	118mm	110mm
SLE125	1250mm	305mm	533mm	226mm	334mm	118mm	110mm
SLE150	1500mm	305mm	533mm	226mm	334mm	118mm	110mm
SLE200	2000mm	305mm	533mm	226mm	334mm	118mm	110mm

The above table contains the **minimum** opening

A = Width to outside of plaster flanges

B = Height to outside of plaster flanges

C = Height of fire (min)

D = Depth from front of fire body to rear of side plaster flange

E = Depth of fire

F = Height of fire above top plaster bead

G = Min height from underside of adjustable foot to underside of lower plaster flange

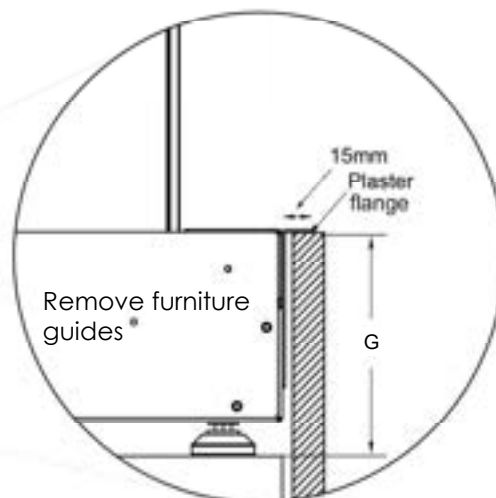
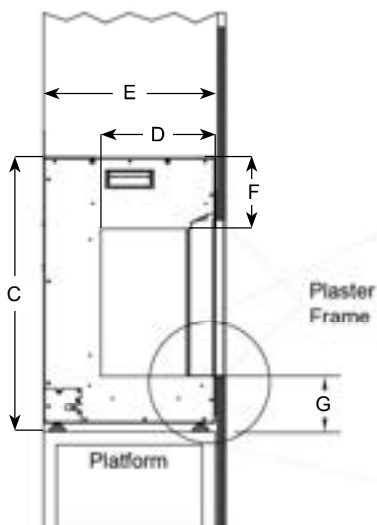

# Installation Instructions

## Installation - Option 2 & 3 - Left or Right Corner View

Remove one steel side panel by removing 12 screws before installation.

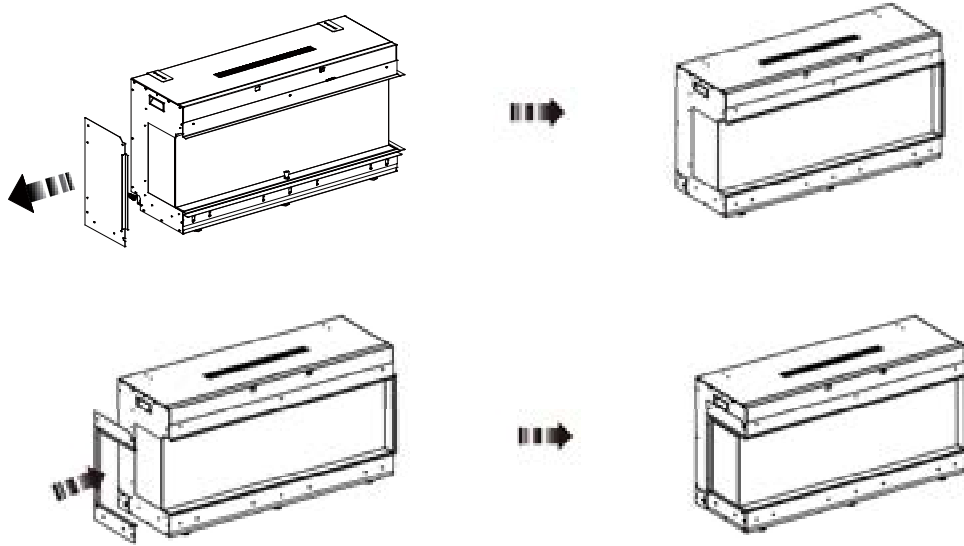

Replace all screws that have been removed.

### Option 2

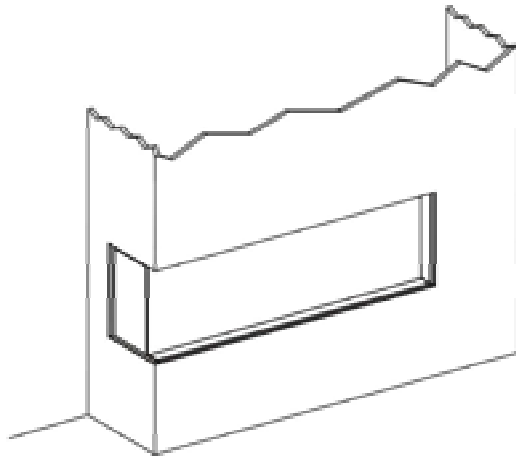

**Note:**

Remove furniture guides for this option.

### Option 3

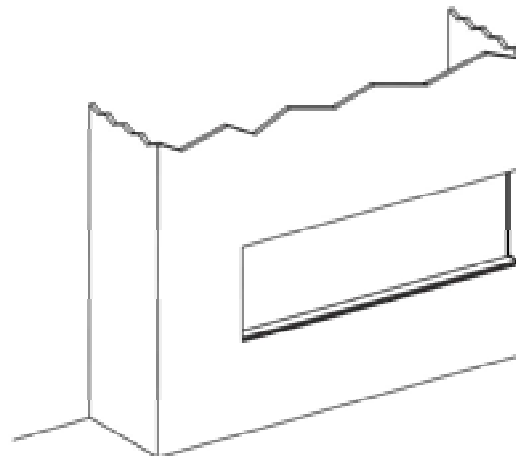

**Note:**

Remove furniture guides for this option.



# Installation Instructions

## Installation - Option 4 - Panoramic Three Sided View

Remove 2 steel side panels by removing the screws before installation.

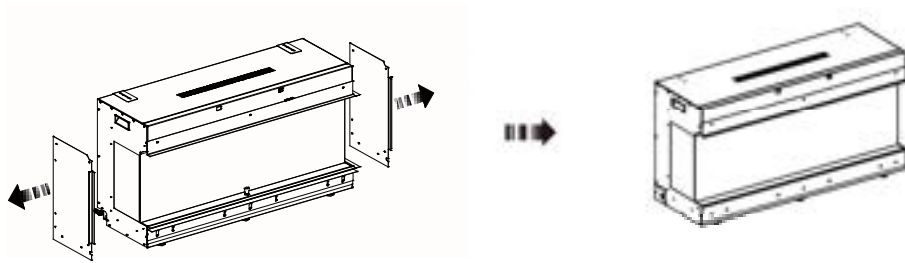

Fix the side plaster brackets and put all the screws back onto side panels.

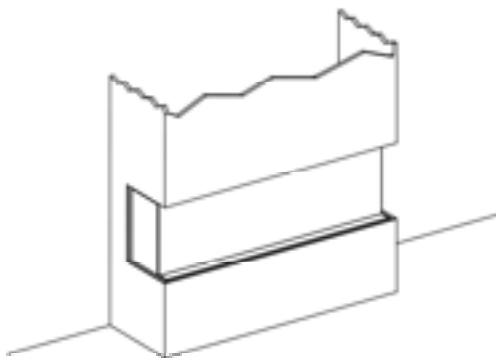
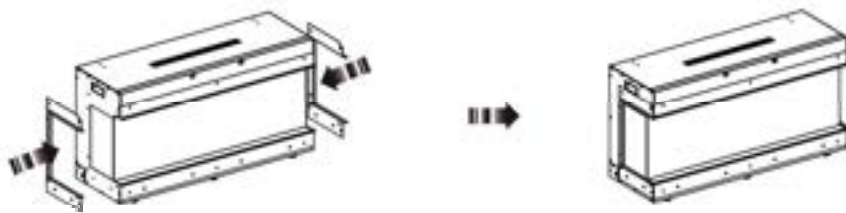

### Option 4

**Note:** Plaster flanges and furniture guides are not for support, ensure all furniture work is independently supported.  
Remove furniture guides for this option.

### Alternative - Floating Base

Slide base onto fire and fix/support securely to the wall.

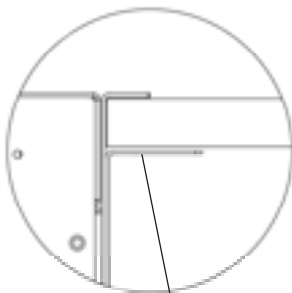

Furniture Guides  
on Front & Sides  
(Adjustable for material  
10-25mm thick)

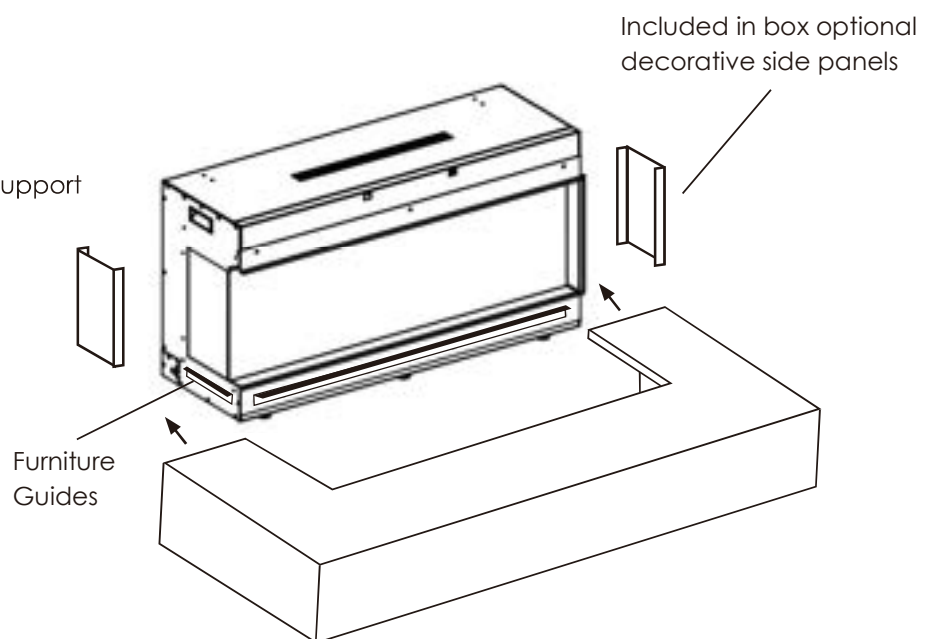

# Operating Instructions

Fig.19

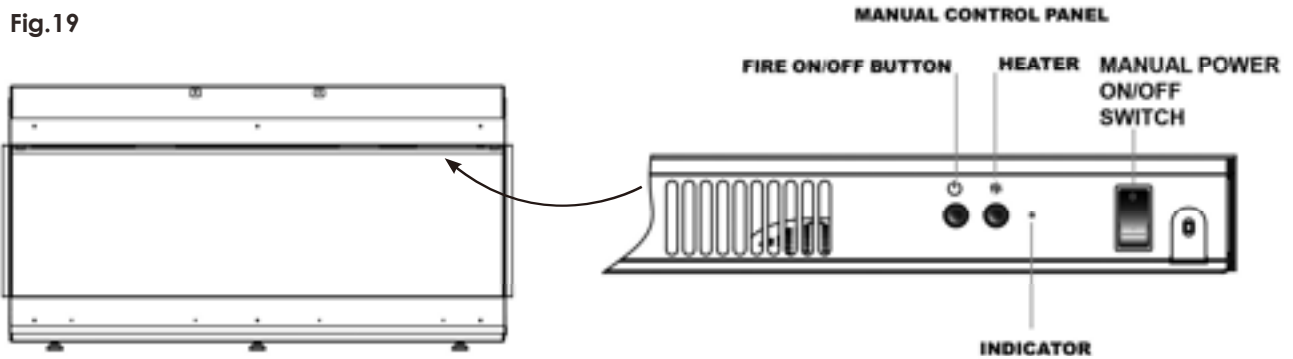

**! NOTE:** The unit can be operated on the manual control panel and with the supplied remote control. For the unit to operate, the manual ON/OFF switch, located on the rightside of the control panel must be switched to the “I” position.

A red light will illuminate when the fire is plugged in and the manual ON/OFF button is switched to “I”. The red light will go OFF once the manual power ON/OFF switch is pushed to ON.

## RED INDICATOR LIGHT

The red indicator light has 2 functions as follows:

1 - Confirmation that power is reaching the fire from the house supply - continuously on until the fire is turned on.

2 - Indication of when the open window device has operated - blinks on for 0.5 seconds and off for 0.5 seconds until the window/door is closed and the heater is turned back on.

Use the manual control panel on/off button to turn your fire on or off. Use the Heater button to cycle through low heat, high heat and heater off.

**NOTE:** The unit may emit a slight, harmless odour and smoke when first used. This odour & smoke is normal and it is caused by heating the internal heater parts and will not occur again.

**NOTE:** Ensure the manual ON/OFF switch located at the top of the front glass on the right hand side is switched to the “I” position.

## Remote Control Buttons and Display

### Powering the Fireplace

Press the fire on/off button to turn on the fire. Press the Power button again to turn off the fire, for added realism the fire will slowly fade before switching off.

**NOTE:** All previous settings are held in memory, so the next time you power up the fireplace, the unit will turn on with the same settings.

### Heater ON/OFF “Heat”

Press the Heater ON/OFF button on Remote Control to switch on or off the Heater.

**NOTE:** As an additional safety feature, the heater will turn off after 12 hours continuous operation in case it has been left on by mistake.

**! NOTE:** Before attempting any operation with the remote, press and slide the battery door (on the back of remote) open and insert two AAA batteries, checking that the + and - ends of the battery match inside the battery compartment, close the battery door.

# Operation Continued

## Remote Control Buttons and Display



### Flame Colour - Flam

Press the Flam button to cycle through the 9 flame colours and off

### Down Light Colour - D Lt

Press the D Lt button to cycle through the 9 down light colours and off

### Scene Light Colour - Scn

Scene lighting is an optional extra and this button will only operate if the Scene lights have been installed.

Press the Scn button to cycle through the 9 scene light colours and off.

### Fuel Bed Colours - Fuel

Press the Fuel button to cycle through the 9 fuel bed colours and off

NOTE: If you have turned off all but one of the lighting elements, you will not be able to turn off the last one using these buttons. This is for you to know that your fire is still powered on.

### Custom Setting - Cust

Using the 4 buttons detailed above, select your desired fire colours and then hold down the Cust button for 4 seconds. This will enable you to recall that setting each time you momentarily press the Cust button. To overwrite your setting, simply choose another set-up for your fire and hold down the Cust button for 4 seconds.

### Dimming Buttons - Dim- and Dim+

Use these buttons to set the brightness level of your fire.

### Flame Preset - PS

Press the Flame Preset button to cycle through the 6 factory set preset lighting options.

### Volume - Vol

Press the Volume button to cycle through the volume settings from off to loudest, back to off.

**IMPORTANT NOTE:** The fan will run for approximately 10 seconds after the heating function is turned off to remove any residual heat from the unit to protect the control components from any potential overheating. Do not press heater ON/OFF button again as this will turn the heat back on.

**Open Window Device function:**

To ensure minimum energy wastage, this appliance will turn off the heaters should an open door or window be detected. When the heater is in operation (H01 or H02) and once the ambient temperature drops 5°C within 10 minutes, the appliance heaters will turn off automatically. Upon activation of the Open Window Device, the red indicator light will blink on for 0.5 seconds and then off for 0.5 seconds, repeating until the heaters have been restarted. Close the window/door or turn off any cooling items, push the heater control buttons on remote control to restart the heaters. To prevent nuisance activations of this device please ensure that there are no open vents in the vicinity of the fire or the furniture it is housed in.

# Product Dimensions

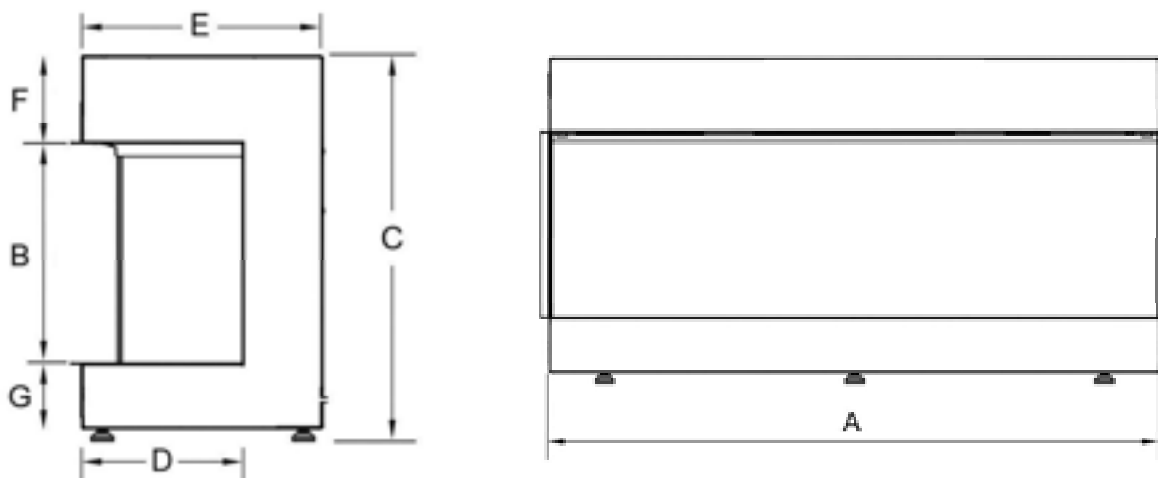

Dimensions							
	A	B	C*	D	E	F	G*
SLE75	750	580	808	226	334	118	110
SLE100	1000	305	533	226	334	118	110
SLE125	1250	305	533	226	334	118	110
SLE150	1500	305	533	226	334	118	110
SLE200	2000	305	533	226	334	118	110

\*These fires stand on adjustable leveling feet so this is a minimum dimension

**Note:** Dimensions stated are in millimetres unless otherwise stated and may be subject to a small tolerance.

## Commissioning and Handover

On completion of the installation:

- Ensure that the operating instructions for the unit are left with the customer.
- Ensure to advise the customer on the correct use of the appliance and how to isolate the unit when required.
- Advise the user what to do should smoke or fumes be emitted from the unit.

# Technical Parameters

## Information requirements for electric local space heaters

Model identifier(s): SLE75/SLE100/SLE125/SLE150/SLE200					
Item	Symbol	Value	Unit	Item	Unit
<b>Heat output</b>				<b>Type of heat input, for electric storage local space heaters only (select one)</b>	
Nominal heat output	$P_{nom}$	2.0	kW	manual heat charge control, with integrated thermostat	[no]
Minimum heat output (indicative)	$P_{min}$	1.0	kW	manual heat charge control with room and/or outdoor temperature feedback	[no]
Maximum continuous heat output	$P_{max,c}$	2.0	kW	electronic heat charge control with room and/or outdoor temperature feedback	[no]
Auxiliary electricity consumption				fan assisted heat output	[no]
At nominal heat output	$e_{l_{max}}$	N/A	kW	<b>Type of heat output/room temperature control (select one)</b>	
At minimum heat output	$e_{l_{min}}$	N/A	kW	single stage heat output and no room temperature control	[no]
In standby mode	$e_{l_{SB}}$	0.45	W	Two or more manual stages, no room temperature control	[no]
				with mechanic thermostat room temperature control	[no]
				with electronic room temperature control	[no]
				electronic room temperature control plus day timer	[no]
				electronic room temperature control plus week timer	[yes]
				<b>Other control options (multiple selections possible)</b>	
				room temperature control, with presence detection	[no]
				room temperature control, with open window detection	[yes]
				with distance control option	[yes]
				with adaptive start control	[no]
				with working time limitation	[no]
				with black bulb sensor	[no]
Contact details	Capital Fireplaces Ltd, Units 12-17 Henlow Trading Est, Henlow, Bedfordshire SG16 6DS				

## Cleaning

**NOTE:** Allow the fire to completely cool before cleaning it.

1. Switch off and unplug from the power supply before cleaning.
2. Using a soft, dry cloth, carefully clean the exterior surface of the product.
3. Do not allow water or other liquids to run into the interior of the product, as this is a hazard.
4. Lightly run a vacuum cleaner nozzle over the grills along the control panel to remove any dust or dirt that may have accumulated inside or on the unit.

**CAUTION:** Do not use harsh detergents, chemical cleaners or solvents as they may damage the surface finish of the plastic components.

## Thermal Safety Cut-Out

A thermal safety cut-out is incorporated in the heater to prevent damage due to overheating. This can happen if the heat outlet is restricted in any way. The heater will switch on once the heater has cooled. If the cut-out continues to operate intermittently, the heater should be switched off and a service agent contacted.

## Light Emitting Diode

This fire is fitted with LED's (Light Emitting Diodes) in place of traditional incandescent bulbs. These generate the same light levels as traditional bulbs, but use a fraction of the energy consumed.

## Battery Replacement Remote Control

**Battery information - see Fig. 35**

1. Slide open the battery cover on the back of the remote control
2. Install AAA batteries into the remote control
3. Replace the battery cover



**Fig.35**

### Discard leaky batteries

Dispose of batteries in the proper manner according to local regulations.

Any battery may leak electrolyte if mixed with a different battery type, if inserted incorrectly, if all the batteries are not replaced at the same time, if disposed of in a fire, or if an attempt is made to charge a battery not intended to be recharged.

# Troubleshooting

**(IF IN DOUBT isolate the appliance and seek professional advice)**

## **The unit does not switch on:**

- Check main power on/off switch is on and red light on control panel illuminates. If the light does not illuminate check the power to the fire from the wall and check the fuse in the plug and the circuit breakers in the distribution panel.
- Check the battery in the remote control handset.
- If none of the above work, then please refer to your retailer.

## **The heater smells of burning:**

- On first uses there may be a smell as the heating elements burn off residual deposits from manufacture.
- After periods of no use, dust can settle on the elements and will burn off. Excessive dust and fluff is a fire risk and should be eliminated by following the service and maintenance steps on page 20.
- If smell continues, please refer to your retailer.

## **When the heater is switched on it cuts itself off.**

- This could be the normal operation of the thermostat having been set to a target temperature which has been reached, and is fine.
- This could be the safety thermal cut-out device operating. If this operates, then firstly isolate the appliance from the mains and then check for obstructions to the air flow and remove them. This could be fluff in the control panel grills, for example. Once the obstruction(s) have been removed, let the appliance cool down for 15 minutes and then reconnect the appliance to the mains and try the appliance again. If the issue persists, then seek the advice of your retailer.
- As an additional safety feature, the heater will turn off after 12 hours continuous operation in case it has been left on by mistake.

## **The appliance seems to work, but no lights are illuminated.**

- Check the flame effect and fuel bed lights have not been turned off from the remote.
- Turn fire off then back on after 2 minutes.
- Please refer to your retailer.

## **SLE fire sounds**

- Your fire will make some sounds during normal operation. There are four sources of sound:

**1. Switch/thermostat** - During operation they will make quiet clicking sounds and will occur when your heater fan and heating elements are switched on or off.

**2. Flame Effect** - To ensure you experience a slow and relaxed flame effect speed, the electric motor provides its drive via an internal gearbox that will emit a very faint gear noise.

**3. Fan Heater** - just like any fan heater there will be the sound of air being blown into the room.

**4. Sampled Fire Sounds** - The SLE75, 100, 125, 150 and 200 feature a fire audio option. The volume of this sound can be adjusted using your handset or smart device. Excessive noise should be referred to your retailer.

## **The thermostat reading on the screen does not match the room temperature.**

- The thermostat reading is of the ambient temperature in the immediate vicinity of the fire. It may be necessary to set a higher target temperature in some instances. In some cases it may be more suitable to turn on the heating element(s) without setting a target temperature – see heater instructions.



## Servicing and Maintenance

- There are no user-serviceable components to this appliance – do not attempt to service the appliance. If there are issues that cannot be resolved with your appliance, then please contact your retailer.
- Hard floor covering in particular, but all floor covering cause fluff that can be drawn into the air intakes. From time-to-time and no less than every two months, isolate the fire from the mains and attach the brush accessory to your vacuum cleaner and gently vacuum the air intakes and outlets. (See image below)
- Use only a clean dry duster to clean the surfaces of the appliance. DO NOT use water, abrasive cleaners, steam or other household industrial products or cleaners.

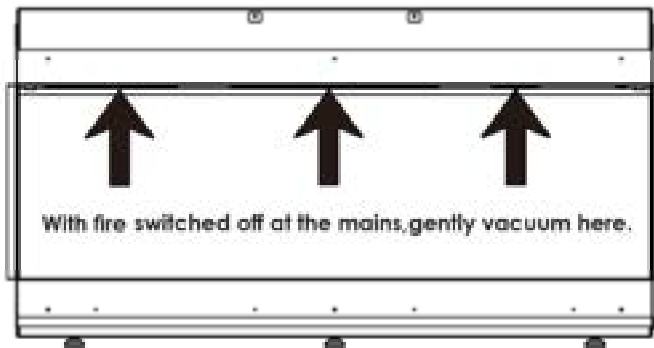

- If you have bought a new handset then you will need to pair it with your fire. This can be done with your fire turned on using the switch on the fire and holding down the new handset "Heat" and "Vol" buttons simultaneously for 5 seconds. Upon successful connection the fuel bed of your fire will flash 3 times.

## Correct Disposal Of This Product

This marking indicates that this product should not be disposed with other household wastes throughout the EU. To prevent possible harm to the environment or human health from uncontrolled waste disposal, recycle it responsibly to promote the sustainable reuse of material resources. To return your used device, please contact the retailer where the product was purchased. They can take this product for environmental safe recycling.



# Solution Fires Warranty

All Solution Fires come with a standard 1 year parts warranty extendable to 2 years on registration.

Any fire purchased outside of our authorised dealer network will carry a 1 year non-extendable warranty.

To activate your extended warranty, you must register your fire online at [www.solutionfires.co.uk](http://www.solutionfires.co.uk) within one month of the purchase date. Any fires registered after this period will carry a 1 year non-extendable warranty.

**For full details of our warranty and to view the limitations and exclusions please visit our website [www.solutionfires.co.uk](http://www.solutionfires.co.uk)**

For added peace of mind, why not purchase our Platinum Warranty Plan for a one off payment of £49.99 which gives you peace of mind for 5 years from date of purchase on all included parts and a 25% discount off non included parts and accessories.

The platinum warranty is only available up to 60 days from date of purchase and only to customers who have purchased their fire from an authorised dealer. **Apply via our website [www.solutionfires.co.uk](http://www.solutionfires.co.uk)**

To ensure your Solution Fire continues to operate at its optimum level you must follow the care and maintenance advice in the user instructions.

## Terms & Conditions

This warranty is for domestic use, not transferable and is extended only to, and solely for, the benefit of the original purchaser of the Solution Fire. Please retain your dated sales receipt as a proof of purchase.

During your warranty period, only genuine Solution Fire spare parts must be used in the servicing and maintenance of your Solution Fire, these spare parts can be ordered from [www.solutionfires.co.uk](http://www.solutionfires.co.uk), or directly from a Solution Fire Retailer. Items considered as consumable such as glass, screens, bulbs, LED boards, ceramic logs, fuses and batteries which are either subject to normal wear and tear or parts that require replacement in connection with normal maintenance are not covered by the warranty. Loss or damage of any remote

control handsets is also excluded from the warranty.

Should you experience problems with your Solution Fire, any claim must be submitted to the Solution Fire Retailer from where the Solution Fire was purchased.

The Solution Fire warranty does not cover:

- 1) Damage resulting from installation and usage where the appliance has not been installed or used in accordance with the Solution Fire installation and operation instructions, or if the installation does not conform to local building, fire and safety regulations.
- 2) Damage caused by unauthorised modifications, use or repair.
- 3) Damage or defects caused by the product being stored in a damp, unheated environment.
- 4) Consequential loss (to the extent permitted by the law) relating to other associated products that have not been supplied by Solution Fires.
- 5) Consequential loss (to the extent permitted by law) related to decorations, furnishings or other household assets.
- 6) Removal and re-installation costs.
- 7) Accidental damage.

Repaired or replaced components are covered only for the remainder of the original warranty period.

In the event of a product fault occurring during the warranty period, Solution Fires will send the appropriate component to rectify the fault, free of charge.

Nothing in the warranty shall make Solution Fires liable for any or special, incidental or consequential damages, injury to persons or property, or any other consequential loss beyond the consumer's statutory rights. The liability on these issues is covered by Solution Fire Terms and Conditions of Sale.

Solution Fires total liability extends only to the purchase price paid for the goods, except where such a limitation is prohibited by statute. Solution Fires, in the event of a warranty claim, reserves the right to either replace the goods in question or to refund the purchase price of the goods. The Solution Fire warranty does not affect your statutory rights.

# Exploded View

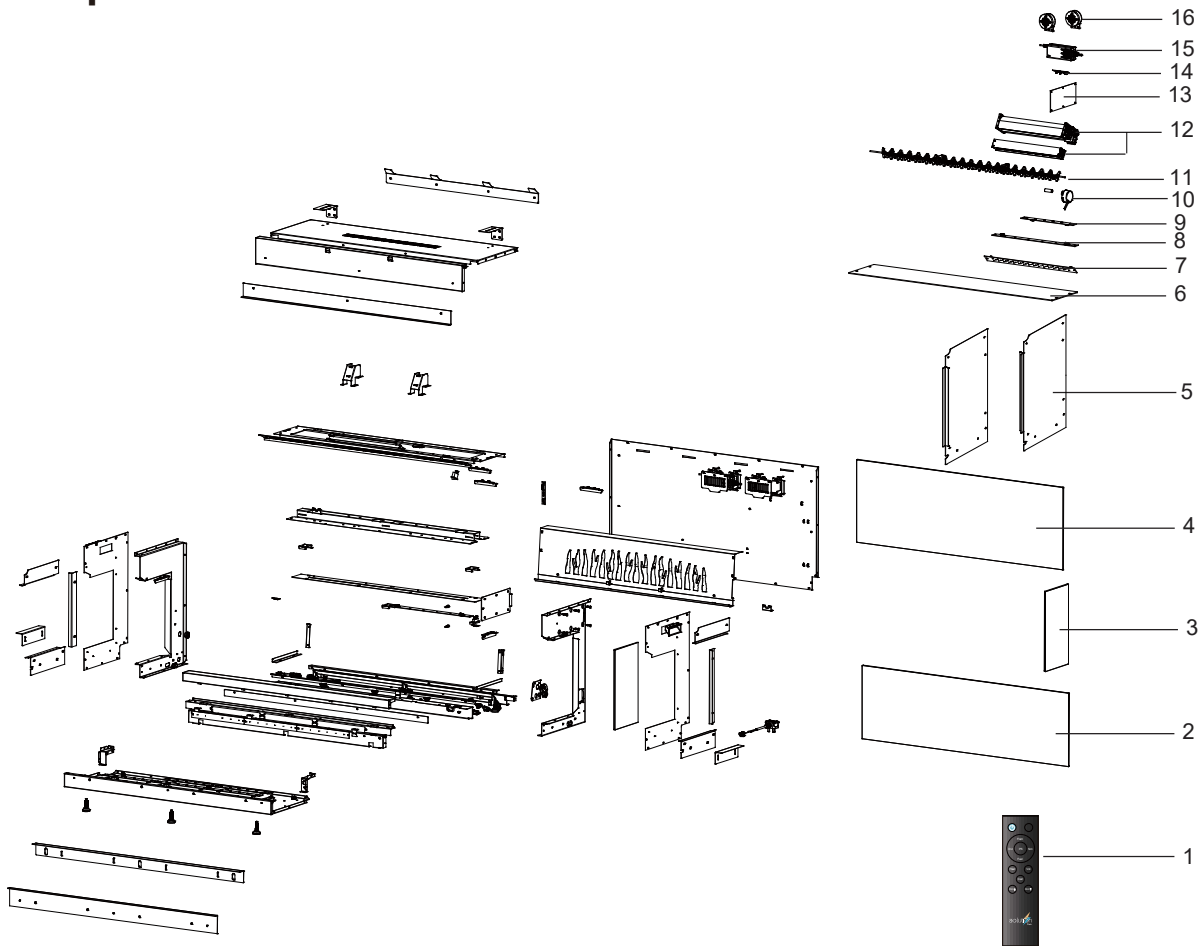

## Replaceable Parts

No	Description	Part Number				
		SLE75	SLE100	SLE125	SLE150	SLE200
1	Remote Control Handset	2203126	2203126	2203126	2203126	2203126
2	Front Glass Plain	2203012	2203013	2203014	2203014	2203015
3	Side Glass Plain	2203017	2203018	2203018	2203018	2203018
4	Flame Screen	2203021	2203022	2203023	2203023	2203024
5	Steel Side Panels (Pair)	2203025	2203026	2203026	2203026	2203026
6	Fuel Bed	2203033	2203034	2203035	2203035	2203036
7	Flame Effect Lights	2203122	2203122	2203122	2203122	2203122
8	Down Lights	2203043	2203043	2203043	2203043	2203043
9	Fuel Bed Lights	2203045	2203045	2203045	2203045	2203045
10	Flame Motor and Bush	2203048	2203118	2203118	2203118	2203118
11	Rotisserie	2203083	2203084	2203085	2203085	2203086
12	Heater and Fan Assembly	2203051	2203051	2203051	2203051	2203051
13	Main PCB Board	2203125	2203125	2203125	2203125	2203125
14	Control Board	2203055	2203055	2203055	2203055	2203055
15	Power Supply 5A-12V	2203057	2203057	2203057	2203057	2203057
16	Loud Speakers	2203059	2203059	2203059	2203059	2203059
17	Decorative Side Panels	2203093	2203092	2203092	2203092	2203092

# Wiring Diagram

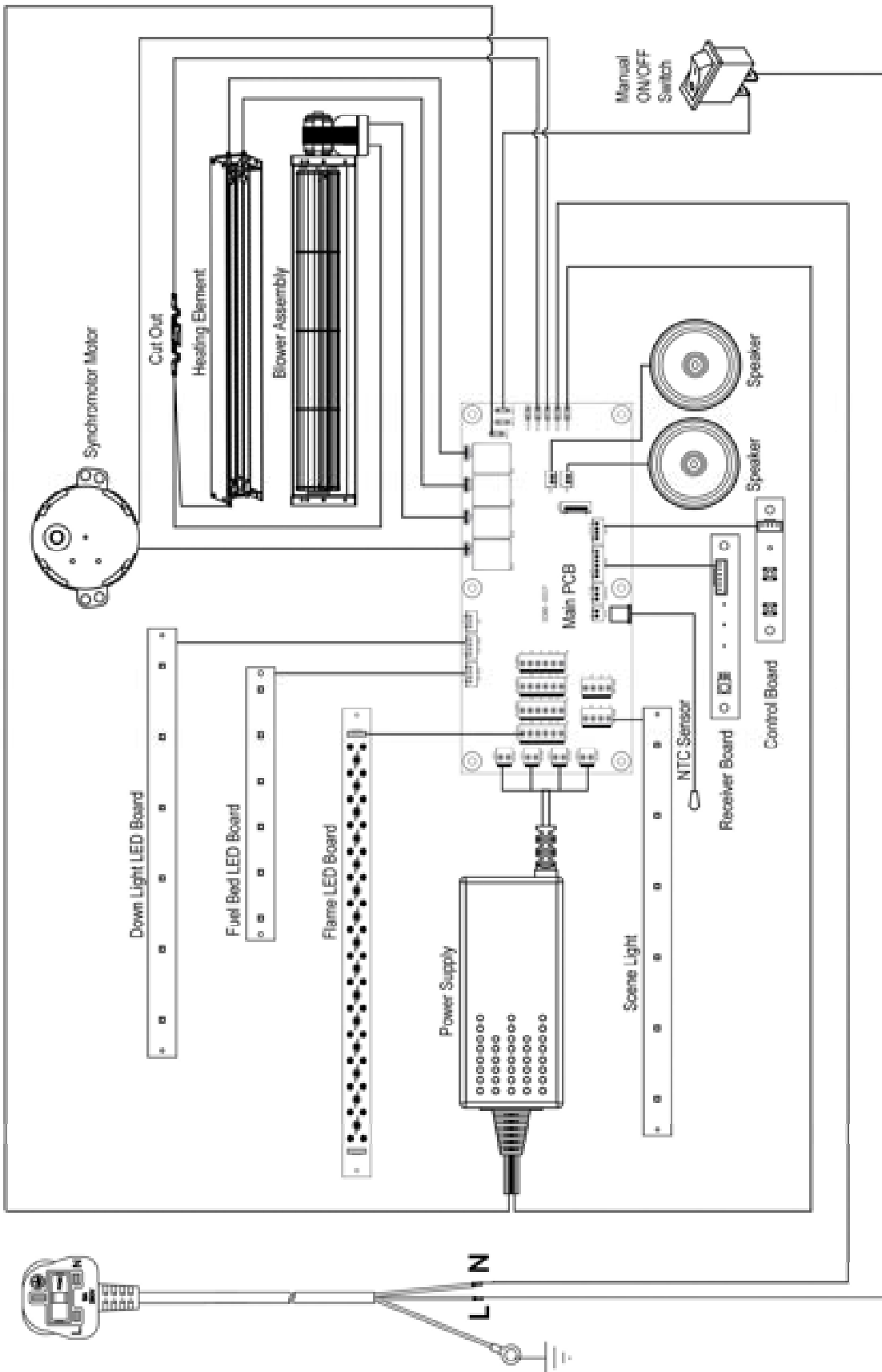



## APP CONTROL INSTRUCTIONS

This section outlines how to set up your fire with your app, how to use the app and further explains the additional features of using a smart watch and Amazon Alexa with your Solution Fire.

From time-to-time improvements will be introduced and we would ask that you periodically check the website [www.solutionfires.co.uk](http://www.solutionfires.co.uk) for updates to these instructions.

Please note the handset that was supplied with your fire and the Solution Fires app work independently of each other. As such neither handset will be able to receive feedback from the other.

# Contents

Pairing your Fire.....	23
Naming Fires.....	29
Adding Fires.....	30
Home Screen Explained.....	31
<b>Accessing Features via Settings Menu</b>	
Target Temperature.....	33
Colour and Brightness.....	33
Sound.....	34
Visual Presets.....	34
7 Day Programmer.....	34
Account Settings.....	36
Smart - Android Wear or Apple iOS.....	37
Amazon/Alexa.....	37
FAQ Relating to the Solution Fires App .....	39

# Pairing your Fire

In the following instructions the numbers adjacent the screen shots correlate with the paragraph numbers. To pair your Solution Fires App with your fire having already installed the fire and controlled it with the supplied handset, please refer to Section 13.

Pairing your Solution Fires App with your fire from installation start-up:

1. Download the Solution Fires App from the App Store, Google Play Store or from our website at [www.solutionfires.co.uk](http://www.solutionfires.co.uk)
2. Plug in the fire and turn it on using the manual power ON/OFF switch shown below.

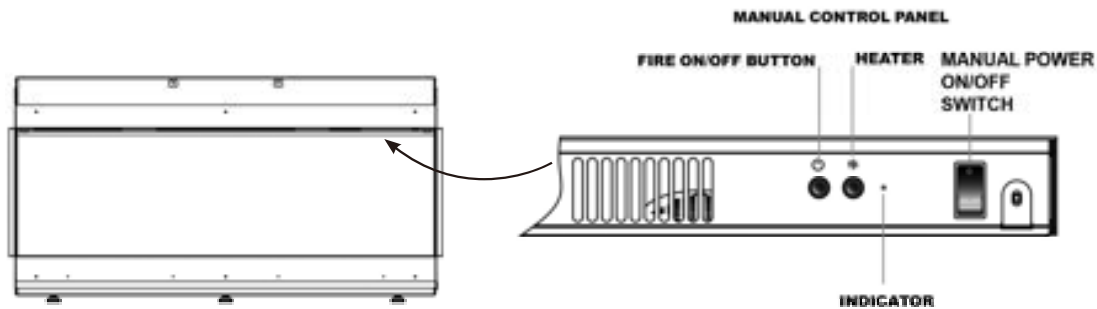

3. Ensure the manual power button is switched to on and the red LED light is illuminated. This indicates that the fire is ready for pairing with the Solution Fires App.
4. Open the Solution Fires App.
5. Wait a moment for the Solution Fires App to initiate and then it will ask you to create an account or log in to your existing account. If you have already registered and signed in to your account, your App will proceed to screen 6. It is essential to have an account in order to use the Solution Fires App. To create an account only your name, a valid e-mail address and a password is required as well as your agreement to the Terms and Conditions. Our Terms and Conditions can also be viewed on our website at [www.solutionfires.co.uk](http://www.solutionfires.co.uk)

**NOTE:** Your fire will connect to the 2.4GHz Wi-Fi signal not the 5GHz signal - please ensure you select the 2.4GHz signal if your router identifies the two signals independent of each other.

During this process you may be asked to allow the App to know your location. This is a requirement of your device. The App will only work if you allow this. The App does not use this information in any way.

1

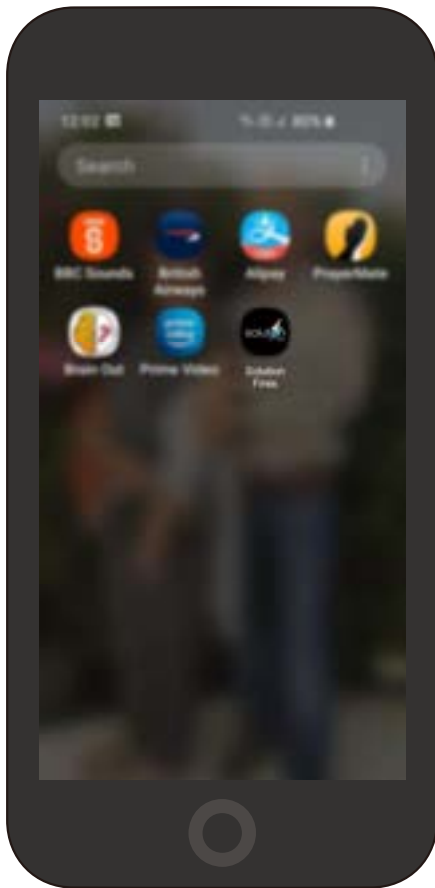

4



5

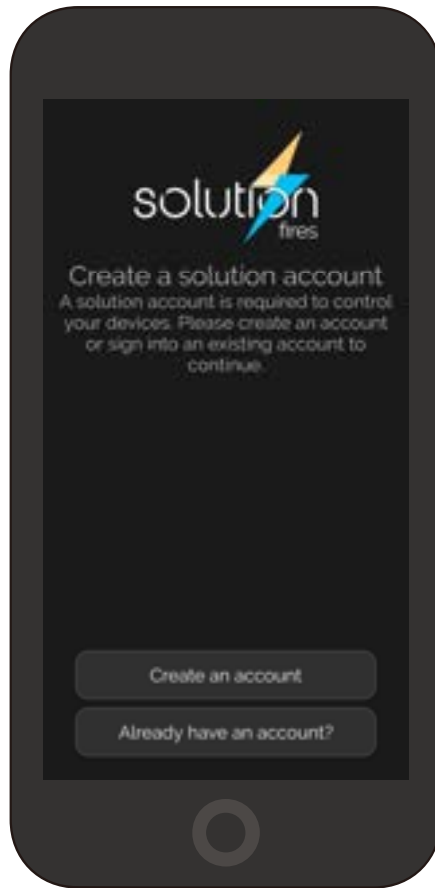

5

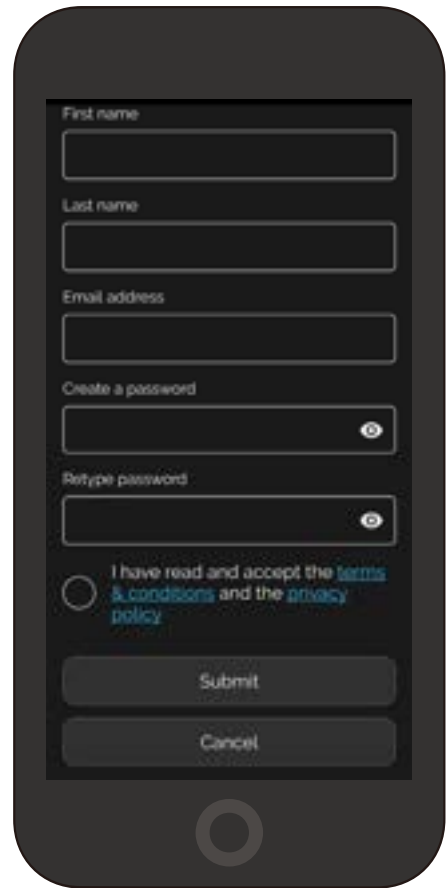



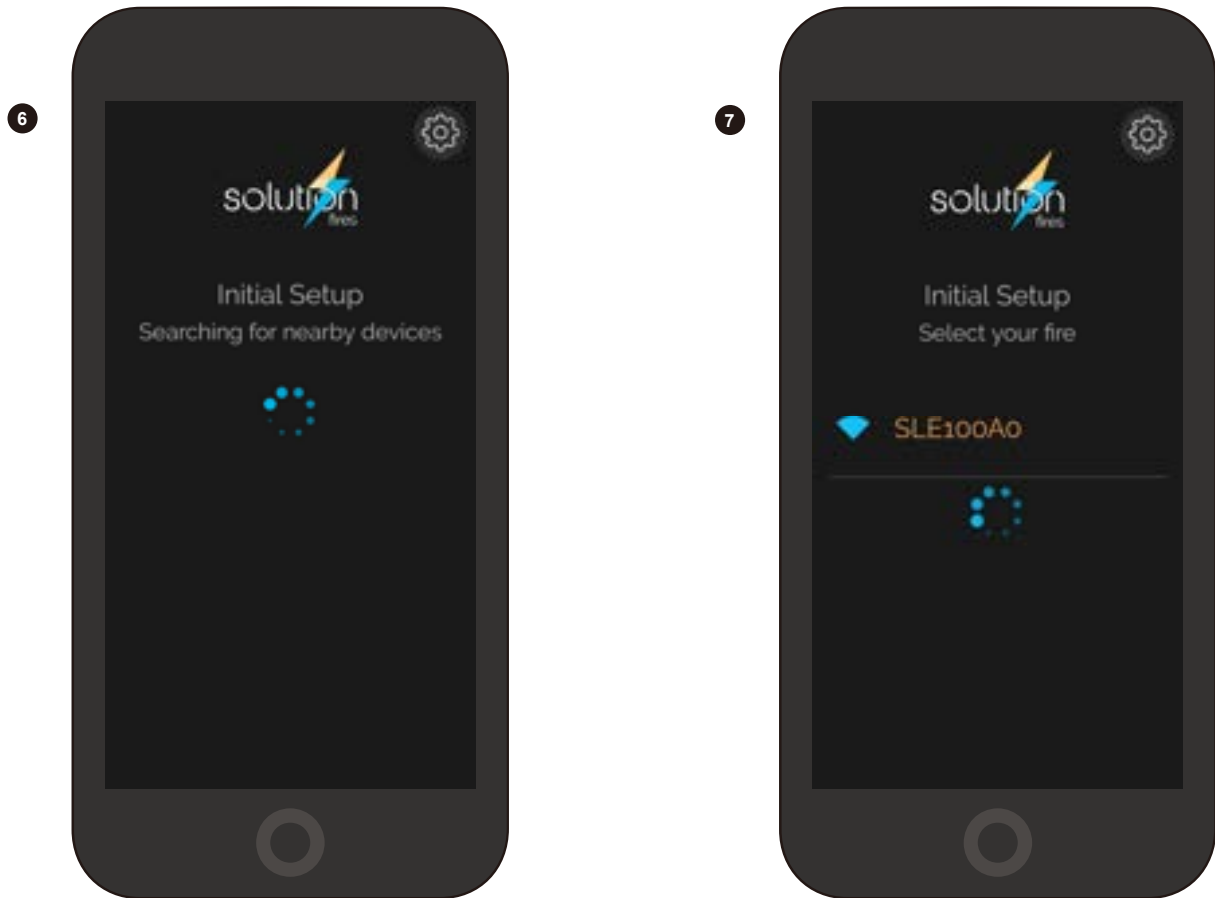

6. Once you have touched the "Submit" button having created an account or logged into your account, the Solution Fires App will start to search for your Solution SLE Fire.
7. Your Solution Fires App will find the fire you are trying to connect to and show it listed on the App screen. The fire will have a unique factory pre-set name similar to "SLE XXXXX".  
If your App does not find your fire then please refer to step 13 below.

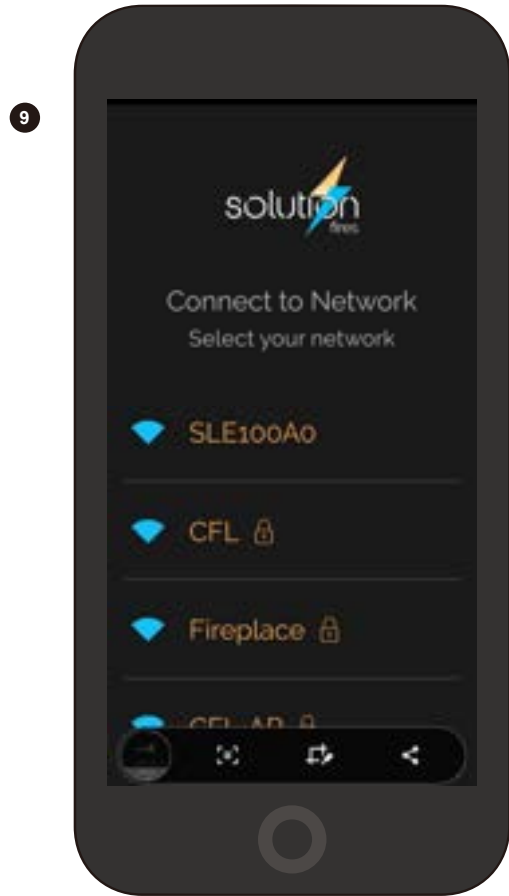
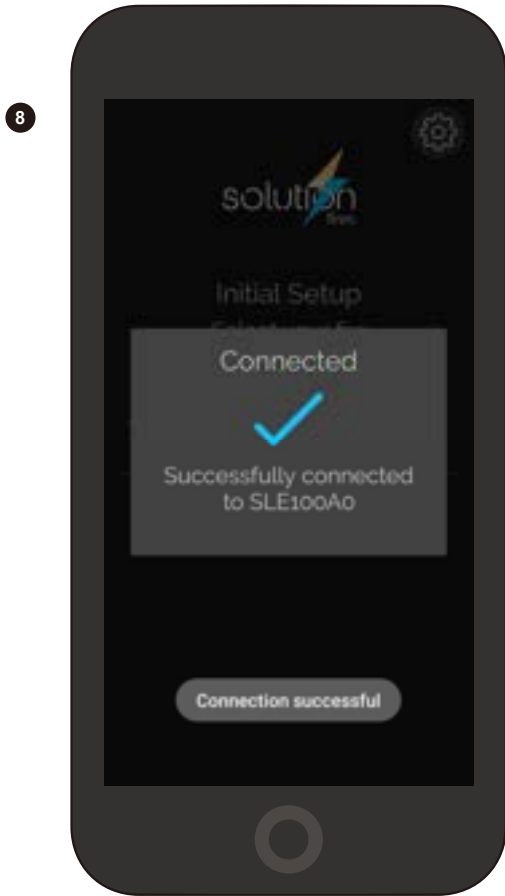

8. Select your fire and your app will then connect and this screen will appear.
9. You will now be directed through the process of connecting your fire to your Wi-Fi network. This screen will list available Wi-Fi networks including the one that your fire has created for this pairing process. Select your home Wi-Fi network that you wish to connect your fire to by touching its name on the screen. For iOS devices, the strongest Wi-Fi signal will be identified and you will be asked for the password for that network. If this is not the network you wish to connect to, then you must type in the name of your desired network manually and provide the password in the normal way. Take care to type accurately.



10. You will now be asked for the password to your Wi-Fi network. Touch the eye icon  to review the password typed in.
11. These two screens pop-up automatically one after the other. Once connected you can turn on your fire and start to enjoy the wide array of features provided to you via the Solution Fire APP. If your fire has not connected, please refer to section 13.
12. The App should now show the home screen. If your home screen does not update with the room temperature within two minutes and two dashes remain beneath the words "Room Temperature" it is likely that you have entered the incorrect password to your Wi-Fi. If this is the case, you will need to restart the process at section 13.
13. If you have been using your fire without an App or if you are waiting a long time and/or your app reverts to the Home screen, but you cannot control your fire then follow the next few steps. Make sure the Manual Power ON/OFF switch is in the ON position. Turn on the fire using the Fire ON/OFF button. Then press and hold the fire on/off button for 10 seconds. This prepares your fire for the pairing process.

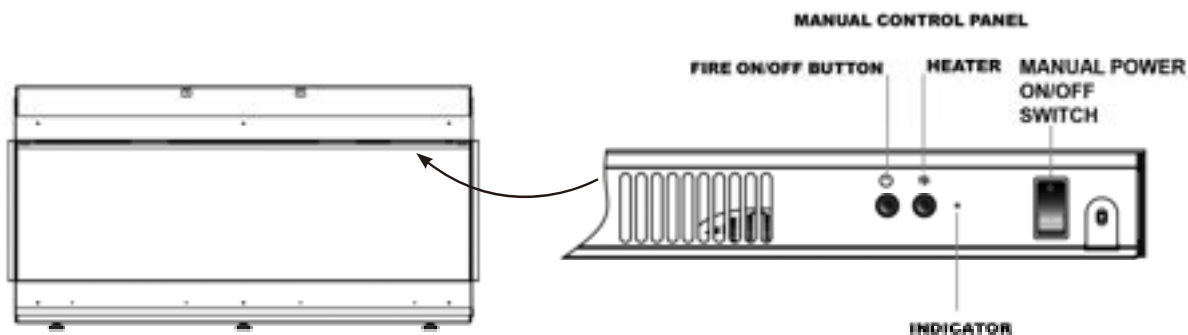

14. Open the Solution Fires Application and follow the instructions from point 5. When you arrive at the Home screen, your fire will take up to a minute to inform the app of the various settings of the fire – for example, the App may be presenting you with the Home screen as shown in point 12 where you can turn on the fire, when in fact the fire is already on. At this juncture, you could turn on the fire which will set the fire to the factory default setting. From that point on, you may start to enjoy the many control features.

10

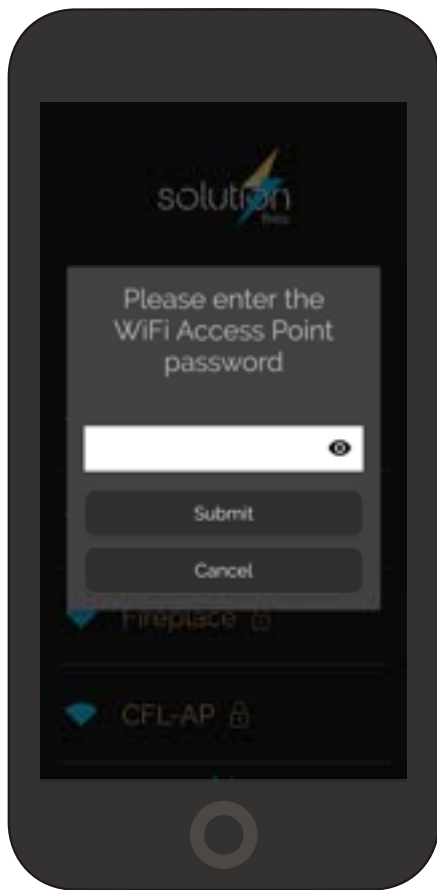

11

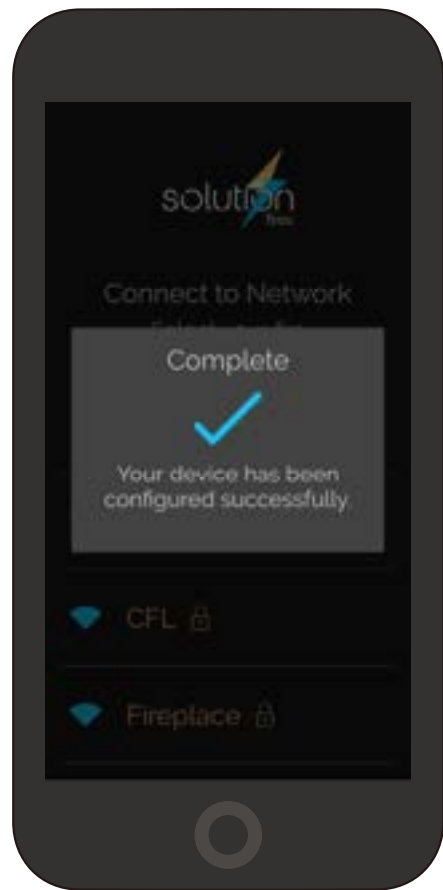

11



12



# Naming Fires

- 15. You may want to change the name of your fire. To do this, touch the settings  button at the top of the Home screen.
- 16. Select Adding & naming fires.
- 17. If you have more than one fire listed here you can rename them all one by-one. Touch the blue "pad and pencil" button adjacent the fire whose name you would like to change.
- 18. Type new name and then submit.

15

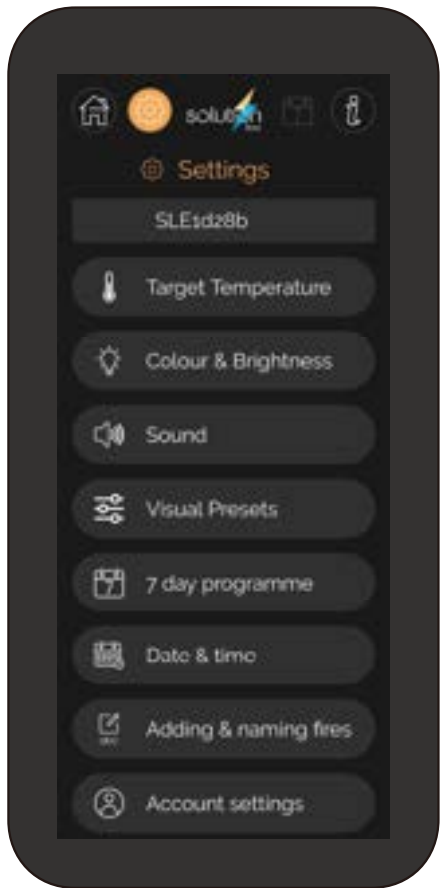

16



17



# Adding Fires

- 19. You may want to add another fire so that you can control up to 5 fires from your App. To do this, touch the settings  button at the top of the Home screen.
- 20. Select Adding & naming fires.

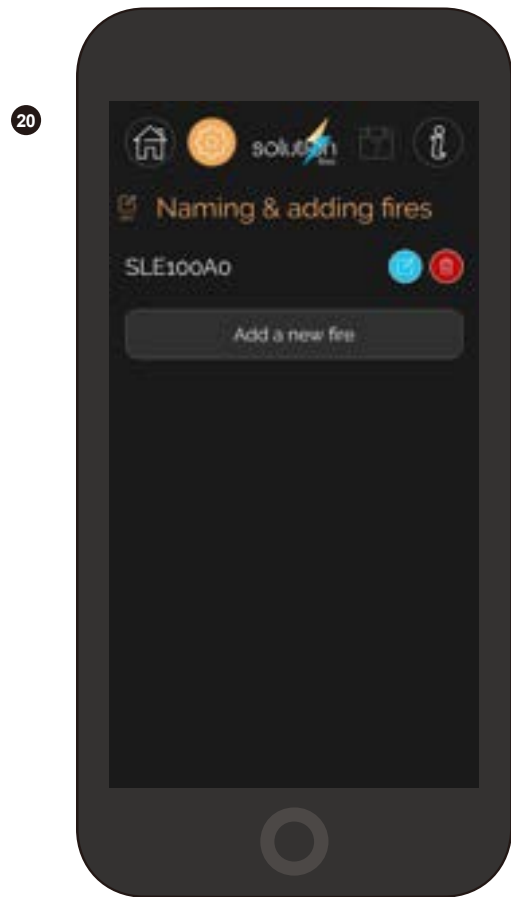
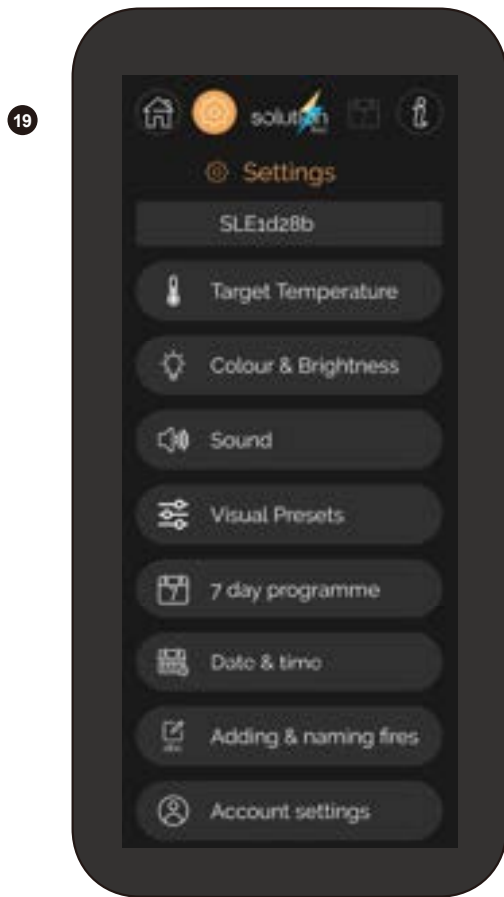

- 21. Select "Add a new fire" and follow the instructions from point 6 in the **Pairing your Fire** section of these instructions.



# Home Screen Explained

22-27



- 22.** Across the top of the screen, there are two icons/buttons each side of the Solution fires logo. To the left are the Home button and the Settings button. To the right are the 7-day timer button and the Instructions button.
- a.** The home button will bring you back to this screen whenever you touch it.
  - b.** The settings button takes you to the settings menu from where you can select one of the seven main control features of your fire and administer your account.
  - c.** The 7-day programmer button will be bright if you have set the 7-day timer function and is a short cut button to the screen where you are able to set the 7-day timer.
  - d.** The ⓘ button takes you to the instructions for using your App.
- 23.** Beneath the "Home" logo is the name of your fire. If you have paired your app to more than one fire, then there will be a small arrow to the right of the name. Touching this allows you to select from a drop-down list the fire you would like to control.
- 24.** Room temperature is measured in the vicinity of the fire. When you first pair your fire and App, this may be blank as the app awaits a signal from the fire to confirm the room temperature. This may take up to one minute.

**25.** Manual heater buttons.

- a.** Press  for 1kW of heat or  for 2kW of heat.
  - b.** If you would like your fire to be set-up to reach a room temperature of your choice, then please see section 28 of these instructions on setting Target Temperature. By activating the heater buttons from the Home screen, you override the Target Temperature feature if it has been set.
  - c.** If you have set the 7-day programmer, this will override both the manual heater buttons and the target temperature function.
- 26.** Your fire is equipped with an energy saving device which detects if a door or window is left open by analysing if a sudden drop in room temperature occurs. If this does happen then your fire will automatically stop heating the room, the red indicator light on the manual control panel will blink rapidly and a pop-up warning appears on your application. Follow the instructions on this screen to reset your heater.



- 27. a.** Lights – touching this button takes you to the screen where you can control the colour and brightness (colour only for downlight) of the individual lighting elements of your fire. Please refer to section 30 of these instructions.
- b.** Sound – your fire has a factory pre-set of no sound. This can be adjusted from this button – see section 32 of these instructions.
- c.** Pre-sets – Choose from 6 different factory set fire settings. On the “Visual Presets” screen there is a seventh button which when touched allows you to change your fire to a set-up that you have chosen. Please refer to sections 29-31 of these instructions for more information on how to set up your “Custom Preset”.



## Accessing Features via Settings Menu

(See previous page)

### Target Temperature

28. When you first set up your app, the first time you visit this screen, you will see two dashes instead of numbers. This will change to your setting once you adjust the slider control. Set your desired target temperature for your room.
29. You can select a target temperature between 1°C (34°F) and 30°C (86°F). Once you have set this, your fire will automatically control its heater to warm your room to that temperature and maintain it around that temperature. Set the temperature by sliding the button along the line or by touching the + or – symbols. Save your target temperature as your Custom setting - this would then be activated when you select your “Custom Preset” from the “Visual Presets” screen – please see section 33.

**NOTE** - If you set a target temperature when using the 7-day programmer (section 34), that will not be reflected on this screen when your fire is under the control of your 7-day timer settings.

### Colour and Brightness

30. Select your own colour and brightness settings for each element of your fire. You can also navigate directly to this screen from the Home screen.
31. Select the element of your fire that you would like to adjust – in this case the fuel bed has been selected. Adjust the brightness using the slider or the + and – symbols. Select one of the nine different colours. The “Scene Light” button will be only available if you have added the optional extra Scene Light kit to your fire. Save your light settings as your “custom preset” which would then be activated from the “Visual Presets” screen - please see section 33.

28



30





32

## Sound

32. Mute or adjust the volume of the sound of your fire.

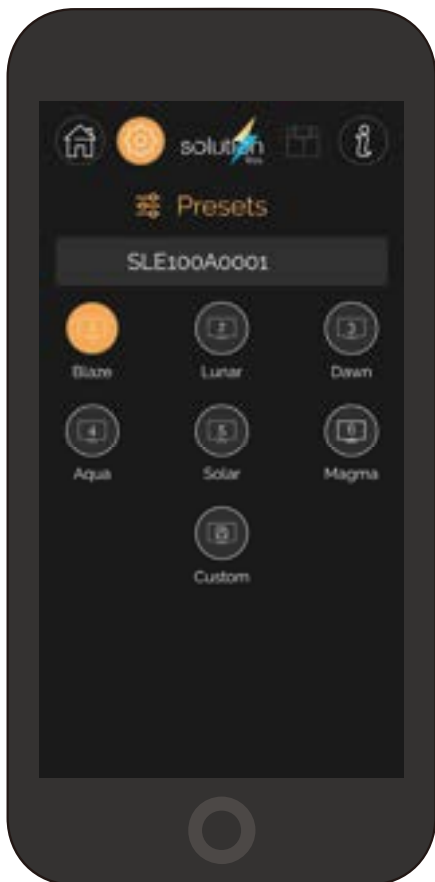

33

## Visual Presets

33. Select any one of the six factory set lighting schemes or your own Custom effect.

## 7 Day Programmer

34



**34.** Your app will automatically take the day and time from your phone or tablet. If you are setting your fire up in a different time zone to the one your phone or tablet was set up in, then first select "Date & Time" from the Settings menu and choose the time zone your fire is located in. Now select "7 day programme" from the settings menu and proceed as follows:

**a.** Turn on the "Use 7-day programme"

**b.** Select whether you wish to control the flame picture only or the flame picture and the heating together.

**c.** Select the days you wish to control. There are "bulk" options of "Weekdays", "Weekends" or "Everyday" or you may wish to set each day separately by simply selecting the initial letter of the day you wish to set.

**d.** Now set the times at which you would like your fire to operate. ON/OFF for "Period 1" by touching the "time on" and "time off" boxes in turn.

**e.** Set the target temperature you would like your fire to heat the room to. This option will not appear if you have elected to control the flame picture only at 34b above.

**f.** If you would like to control your fire for a second period on the same day(s) then follow the same process for "Period 2".

**g. It is essential to touch the "Confirm" button at the bottom of this screen to set the programme.**

**35.** You will notice that any screen you navigate to once you have set the 7-day programmer will have the illuminated calendar icon at the top right-hand side of each screen. This is a quick reference for you to check if your fire has the 7-day programme set or not. You can touch the calendar icon to navigate quickly to the 7-day timer screen.

**36.** To cancel the 7-day programmer, turn off the "Use 7-day programme" switch and press the "Confirm" button. Your previous settings will be retained in case you would like to turn the 7-day programmer back on at some future stage.

**37.** To review your settings, return to the 7-day programme screen and touch each day in turn and review the settings for each day one-at-a-time. You may review one day's setting at time allowing you to make fine adjustments to each day as you require.

**If you do make adjustments, please ensure that you "confirm" your new settings before exiting this screen.**

# Account Settings

38. The Account Settings screen is reached by selecting that button from the Settings menu.

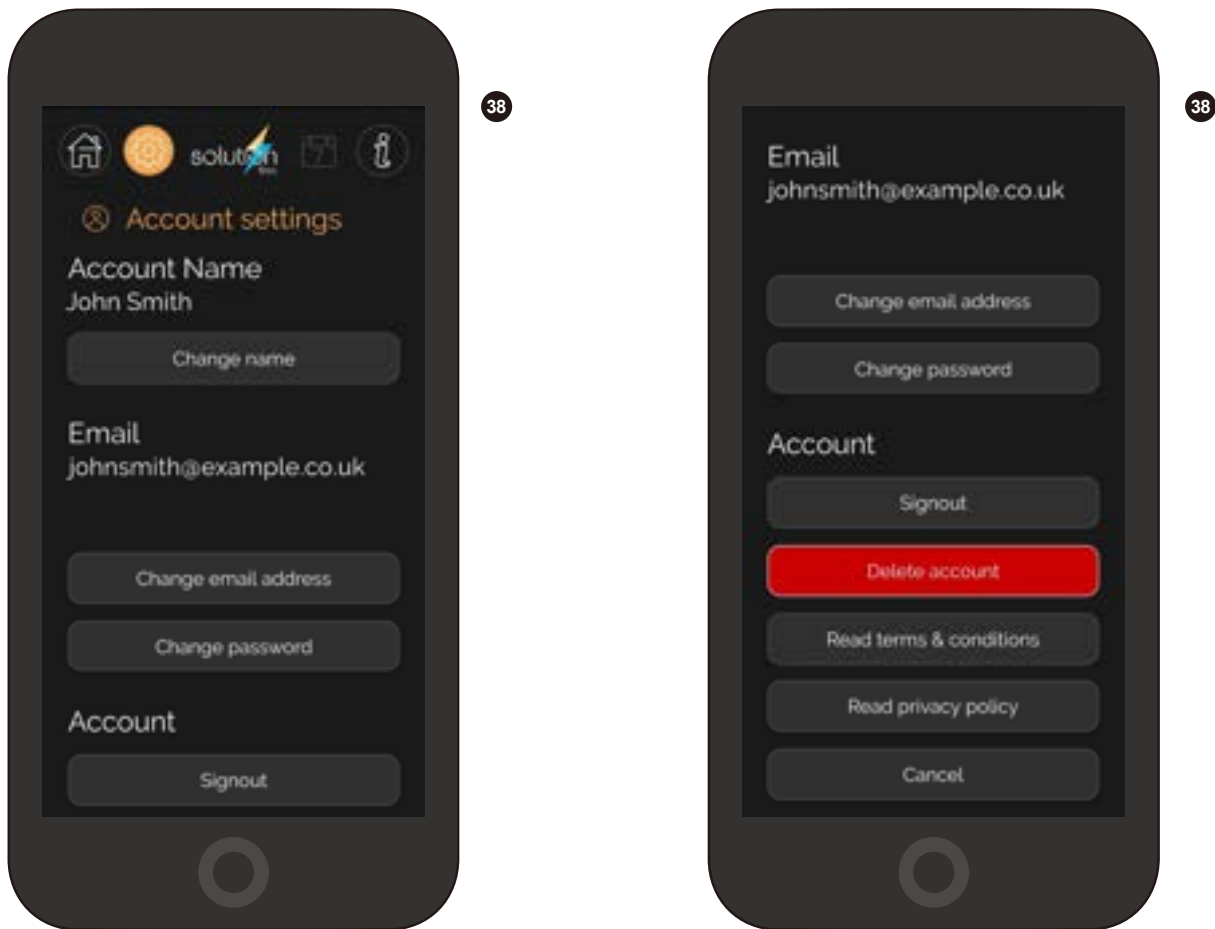

39. The features here assume that you are logged in to your account and are as follows:

- a. You may change the name of your account at any time – tap the “Change name” button where you can change your e-mail address, first and second names. The e-mail address here is the one to which e-mails to help you with forgotten passwords will be sent.
- b. You may change your e-mail address at any time – tap the “Change email address” button where you can change your e-mail address, first and second names. The e-mail address here is the one to which e-mails to help you with forgotten passwords will be sent.

- c. Touch the "Change password" button to change your password at any time. The level of security is entirely up to you.
- d. To avoid others using your app to control your fire, you can "Sign out" of your account at any time.
- e. You may decide to delete the account that you have set up. The main reason for this would be moving home.
- f. Here you may refresh your memory regarding the Terms and Conditions and Privacy Policy by touching the relevant buttons.
- g. "Cancel" takes you back to the Settings screen.

## Smart Watch - Android Wear or Apple iOS

- 40. Having paired your smart watch to the device on which you have already installed the Solution Fire App, you will be able to control the key functions of your fire from your wrist.
- 41. Please do not forget that your smart device and watch need to be in the vicinity of each other for the smart watch to function correctly.
- 42. In the case of the Android Wear Watch you will need to add the app to it by accessing the Google Play Store and adding the Solution Fires app from the phone.
- 43. In the case of the Apple iOS watches (Version 1 is not supported) the app appears automatically on the watch app screen.
- 44. Firstly, open the App on your watch, then the functions that are controllable from your smart watch are:
  - a. ON/OFF
  - b. Heat - 1kW, 2kW, OFF
  - c. Presets 1-7 (watch includes the custom preset if it has been programmed on your smart phone or tablet)

## Amazon/Alexa

- 45. Download the Solution Fires Skill onto your smart device you use to control Alexa. In order to use your Amazon Alexa to control your Solution Fire it is important that you link your Solution Fire with the Amazon Alexa app on your smart device.
- 46. There are two ways in which to ask Alexa to control your Solution Fire, Alexa will control only the first connected fire when there are multi-fire installations;
  - a. "Alexa, open Solution Fires" or "Alexa, Solution Fires"
  - b. "Alexa, [ask/tell] Solution Fires to....."

47. When you open Solution Fires, using option 46a, wait for Alexa to say: "Hi, how can I help?" within one or two seconds make your request from the list below. Alexa will confirm your request and then ask if she can help with anything else, at which point you can make further requests from the list below.
48. When you use the option 46b, add the request from the list below. You can make further requests from the request list after Alexa has confirmed your last request has been followed and has asked you: "Can I help with anything else?"
49. Some people have changed the name from "Alexa", in these cases please use the name you have chosen instead of "Alexa" in the examples above.

50. Request list;

1. "turn power [on/off]"
2. "turn [on/off]"
3. "turn [fire name] [on/off]"
4. "turn heater [on/off]"
5. "set heat level to medium"
6. "turn sound [on/off]"
7. "[mute/unmute] sound"
8. "turn volume [up/down]"
9. "change fire to [pre-set name]"
10. "set pre-set [pre-set name]"
11. "pre-set [pre-set name]"
12. "[pre-set name] effect"
13. "change colour to [pre-set name]"
14. "change pre-set to [pre-set name]"
15. "turn fire to [pre-set name]"

**Pre-set names are as follows, with alternatives to try listed in brackets:**

1. Blaze (orange, one, fire, flame, hot, default)
  2. Lunar (pink, purple, two, space, star, stars, orbit)
  3. Dawn (green, three, sunrise, drawn)
  4. Aqua (blue, four, water, underwater, bubble)
  5. Solar (yellow, five, sun)
  6. Magma (red, six, very red, lava, volcano)
  7. Custom – once you have set it. Its default is "Blaze" (my setting, seven)
51. Please refer to [www.solutionfires.co.uk](http://www.solutionfires.co.uk) periodically to see if any new commands have been added.

## FAQ relating to the Solution Fires App

### 1. Can I review the instruction from my app?

Yes, simply touch the information button at the top of your app screen and the instructions will then appear.

### 2. How do I know that my fire is ready to pair with my Wi-Fi network?

When you turn on your fire for the very first time, your fire will be broadcasting its own signal for you to connect to. If you are not sure, then use your phone or tablet to search for networks and if you see one called something similar to "SLE3df4a", then you know that your fire is ready to connect. Do not connect directly to that network on your phone other than through the Solution Fire app. Now follow the instructions to connect the fire.

### 3. What should I do if my fire is not ready to pair with my Wi-Fi network?

Ensure the manual power button is switched to on (I), using the fire on/off button indicated below, turn on the fire. Now hold the Fire on/off button for 10 seconds to put the fire in its "broadcast mode" ready for you to connect. Now follow the instructions to connect the fire.

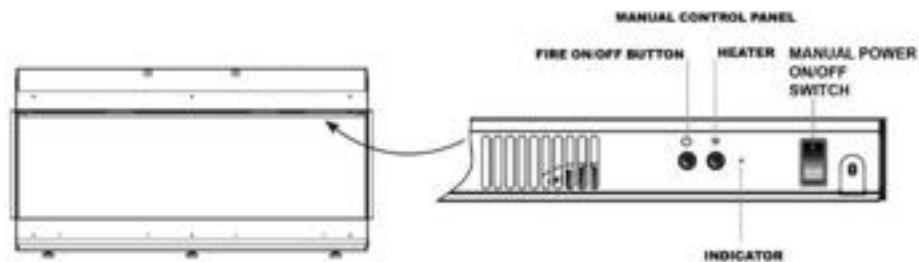

### 4. Must I allow the app to know my location for the app to work?

Yes, this is a requirement of the platforms the apps are built on and the app will not work unless you permit this. This information is not stored or used in any way by Solution Fires. Please refer to the Privacy Policy and Terms and Conditions for further information. You must enable notifications whilst using the app.

### 5. Do I need an account for my app to work?

Yes, it takes a few moments to set up an account with very little information required to set one up. Please refer to the Privacy Policy and Terms and Conditions for further information.

### 6. Must I agree to the Terms and conditions and Privacy Policy to be able to use the app?

Yes, there is a tick box to confirm your acceptance when you set up an. Please refer to the Privacy Policy and Terms and Conditions for further information.

### 7. Do I have to connect the fire to the 2.4GHz Wi-Fi signal in my home?

Yes, in common with most home appliances, the Solutions Fires range will connect only to the 2.4GHz signal from your Wi-Fi router. This is only important if your router has the 2.4GHz signal separated from the 5.0GHz signal.

### 8. Should my smart phone/tablet software be up-to-date?

Yes, please ensure you update your device software regularly.

**9. My phone/tablet does not show the correct home Wi-Fi name for me to connect to, how do I resolve this?**

This can occur if the signal of the desired network is weaker than another in your vicinity. In some cases your device may try to connect to the fire network for its internet access. When you have reached the stage in the set-up process described in the instructions where your app has identified the local Wi-Fi network to connect to, and it is not showing the correct one, simply tap the box where the name is listed and type in the correct one. TIP – it is worth using your phone/ tablet to review the available networks before reaching this stage and noting down the name of your desired network - exactly the characters and spaces as it is shown, because any mistakes in typing it in will prevent your fire from connecting to your network. Please take care to type your password accurately.

**10. My phone/tablet keeps trying to connect to the fire to access the internet, what should I do?**

This can happen, depending on the setting of your device. Go to your settings and select the "SLEXXXXX" network and "forget" it by using one of the menus provided by your device. Once you have done this, you may have to completely reboot your device and restart the pairing process, following the instructions. Please take care to type your password accurately.

**11. Can I view what I have typed in as my password?**

Yes, touch the eye icon in the box where you are typing your password to review the password typed in. The app does not know if you have typed the password correctly or not and so will proceed to its next step of the connection until you find that you are unable to proceed any further.

**12. Can I change my Solution Fires app account password?**

Yes, navigate to the settings page of your app , select "Account settings", tap the "Change password" button and follow the instructions.

**13. What should I do if I forget my Solution Fires app account password?**

When you try to log in to your account there is an underlined "Forgot password" line at the bottom of the screen. By touching this you will be sent an e-mail to the e-mail address you previously registered and from that e-mail you will be able to reset your password.

**14. Is it normal for the red indicator light to blink?**

Yes, this will happen if your Open Window Device has been detected. To reset this, ensure that the cause of the sudden drop in temperature has been resolved and then turn the heater on.

**15. I have previously been able to control my fire using my app, why am I unable to now?**

It is probable that your Wi-Fi signal is weak and has been lost or that your internet access via your router has been interrupted. To stop this it may be necessary to add a booster or improve your internet connection/broadband. You can try rebooting your router. It is also possible that you are using a different account to the one that set up the fire and the account you are using has not been set up. To set up the fire using another account, please follow the set-up procedure in the instructions.



#### **16. Can a busy network affect the performance of my app?**

For best results when controlling your fire your broadband connection should be stable and have sufficient bandwidth to allow speedy connection to the internet. It is possible that the speed of response is affected by heavy use of your Wi-Fi and local heavy 'traffic' at peak times of the day. It is also understood that weather can affect connection speeds.

#### **17. What is causing the fire to take more than one or two seconds to follow the instructions of the app?**

When using the app to set various features, occasionally there is a lag between the time you press the screen button and the signal reaching your fire. Further presses of other buttons will normally operate in the sequence you press them. However, if there are too many button presses in a short period of time the fire can miss an instruction. Simply wait a few seconds and try again if your fire is not responding to the setting you require. The lag can be caused by a number of issues including local network speed, age, version and some settings of devices in the control loop (phone/watch/tablet/operating system/router), Wi-Fi signal strength and local internet stability. Please check these. Often a reboot of your router and/or fire can help.

#### **18. Why is my room temperature not updating on my app home screen?**

If your home screen does not update with the room temperature within two minutes and two dashes remain beneath the words "Room Temperature" it is likely that you have entered the incorrect password to your Wi-Fi when setting up your fire. If this is the case, you will need to restart the process.

#### **19. Is it possible to add another Solutions Fire to my app?**

Yes, navigate to the settings page of your app, select "Adding & naming fires", tap the "Add a new fire" button and follow the instructions.

#### **20. Can I rename my fire?**

Yes, navigate to the settings page of your app, select "Adding & naming fires", tap the blue "pen and pad" icon adjacent the fire whose name you would like to change and follow the instructions.

#### **21. Can I set a 7-day timer programme for my fire?**

Yes, navigate to the settings page of your app, select "7 day programme" and follow the instructions. There is a short cut to this screen – at the top of any screen is a calendar button – touch that and you will be taken to the programme screen. Please remember to turn on the switch that says "Use 7-day programme" and "confirm" your settings at the bottom of the programming screen. Once you have done this, you will notice after a minute or two that the calendar button at the top of your app screen will highlight.

#### **22. Is it possible to store my favourite settings so I can recall them at a later date?**

Yes, once you have set your desired look and sound, press the "Save as custom" button at the bottom of any of the "Colour & Brightness", "Sound" or "Target Temperature" screens. You will then be able to revert to those settings from the "Pre-sets" screen by touching the "Custom" button.

#### **23. Can I set independently the colours and brightness of the different lit elements of my fire?**

Yes, navigate to the "Colour & Brightness" screen from the "Home" screen by touching the "Lights" button. Here you can adjust the colours by touching the relevant colour selection button, of the flame, fuel bed, down lights and scene lights (if fitted). Here you can also adjust the brightness of the flame, fuel bed and scene lights (if fitted) by using the slider control on the screen or by touching the "+" or "-" buttons at the end of the slider. Once set, you can save your bespoke fire settings as your custom setting – please see instructions for more information.

**24. Can I adjust the volume of the fire sound coming from my fire?**

Yes, simply navigate to the "Sound" screen from the "Home" screen by touching the "Sound" button. Here you can mute the crackling sound of your fire or, when it is not muted, adjust the volume of the sound by using the slider control on the screen or by touching the "+" or "-" buttons at the end of the slider.

**25. Are there some pre-set fire settings for me to review?**

Yes, these can be reviewed by touching the "Pre-sets" button on the "Home" screen and selecting one of the buttons on that screen.

**26. Can my smart watch control my fire?**

Yes, once you have paired your fire with the phone or tablet that is connected to your smart watch you can select the app on your smart watch as per the instructions for your smart watch. Using your smart watch you can control the fire on/off, mute the sounds, select pre-sets and turn on and off the heater.

**27. What should I do if my smart watch stops controlling my fire?**

Your watch may sometimes cease to control your fire because the signal between your watch and phone has been interrupted. This can be due to the distance between your watch and phone. It can also be due to your phone optimising its battery usage. Your phone is likely to be optimising its battery usage when its charge has reached about 20% or less. When optimising, the phone will divert battery power to other, more essential functions. You may be able to adjust your optimisation settings on your phone. Alternatively a solution is to charge your phone and double check the connection between your phone and watch.

**28. Can I control my fire using Alexa?**

Yes, open the Amazon Alexa app on your device and search for the Solution Fires skill and link your account to the Solution Fires account you have set up in your app, then try some of the commands listed in the instructions. For example: "Alexa, [ask/tell] Solution Fires to change colour to pink"

**29. Will the app be updated occasionally?**

From time-to-time improvements will be introduced – please refer to the [www.solutionfires.co.uk](http://www.solutionfires.co.uk) website for updates to these instructions.

**30. Can I use the remote control handset at the same time as the app?**

Please note that the remote control handset supplied with your fire and the app work independently of each other. As such neither handset will be able to receive feedback from the other, therefore whichever handset is used your last settings in that handset will be sent to the fire. This can mean after using your app, when you ask the heater to come on with the remote control your fire colours may change to the last ones set in the remote control if they are different from those colour set by the app last time.



[www.solutionfires.co.uk](http://www.solutionfires.co.uk) | [info@solutionfires.co.uk](mailto:info@solutionfires.co.uk)

CAPITAL FIREPLACES LTD, Unit 12-17 Henlow Trading Estate,  
Henlow Camp, Bedfordshire, SG16 6DS. UK.