

Strata

Low Shelving

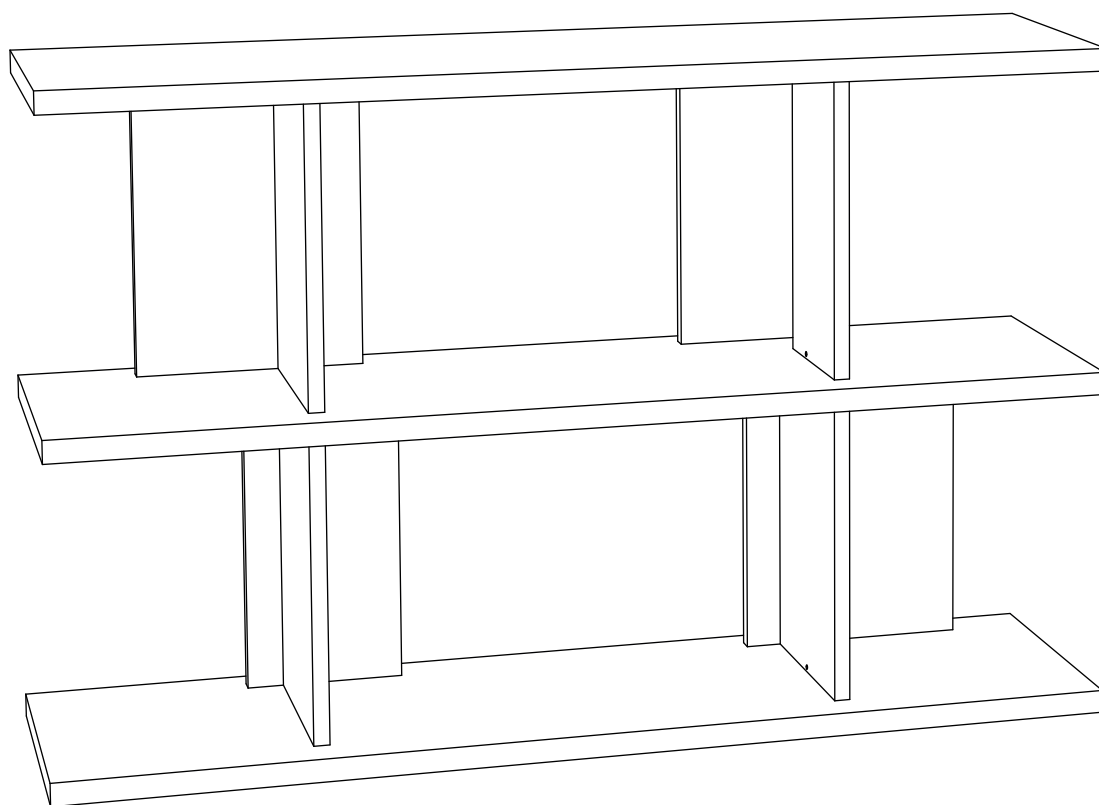

Configurations

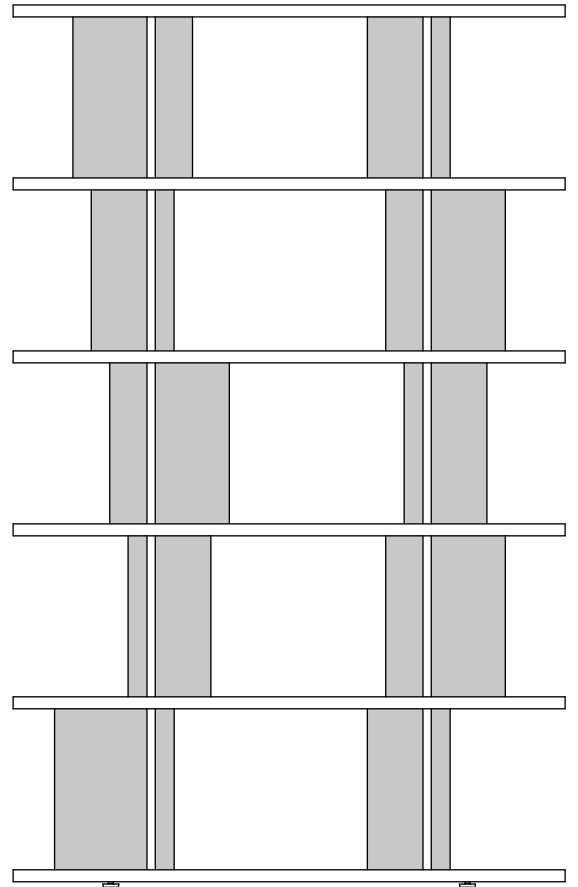
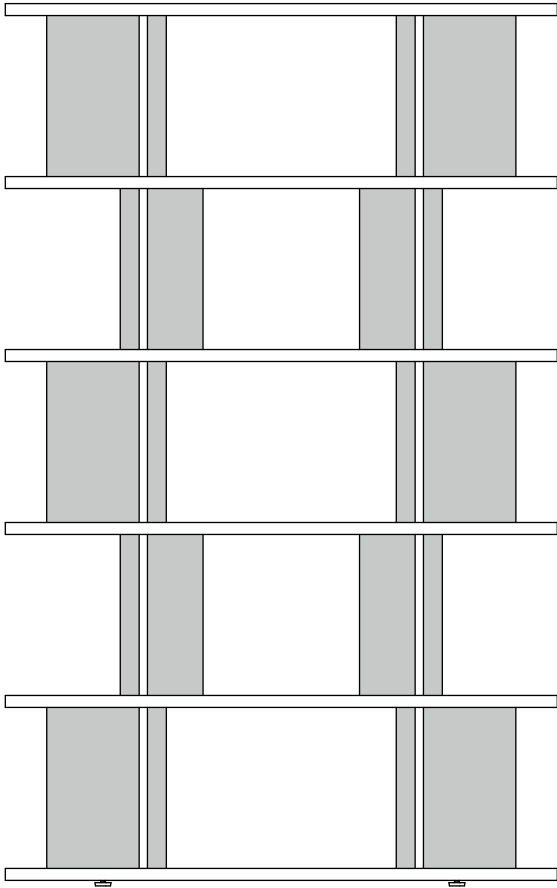

The vertical panels can be varied to your choosing, this page highlights how the back panels can be varied. Have fun and try out different variations to find what you like best.

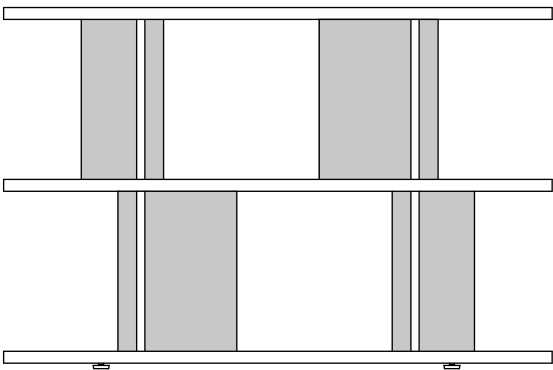

Assembly Instructions

1

Identify the top, 3rd and bottom shelves. The bottom panel will have 4 feet inserted into its underside - the 3rd shelf will have an extra 2 holes at each end on its underside and the top will have no holes on its upper surface. All other shelves can be used in any order.



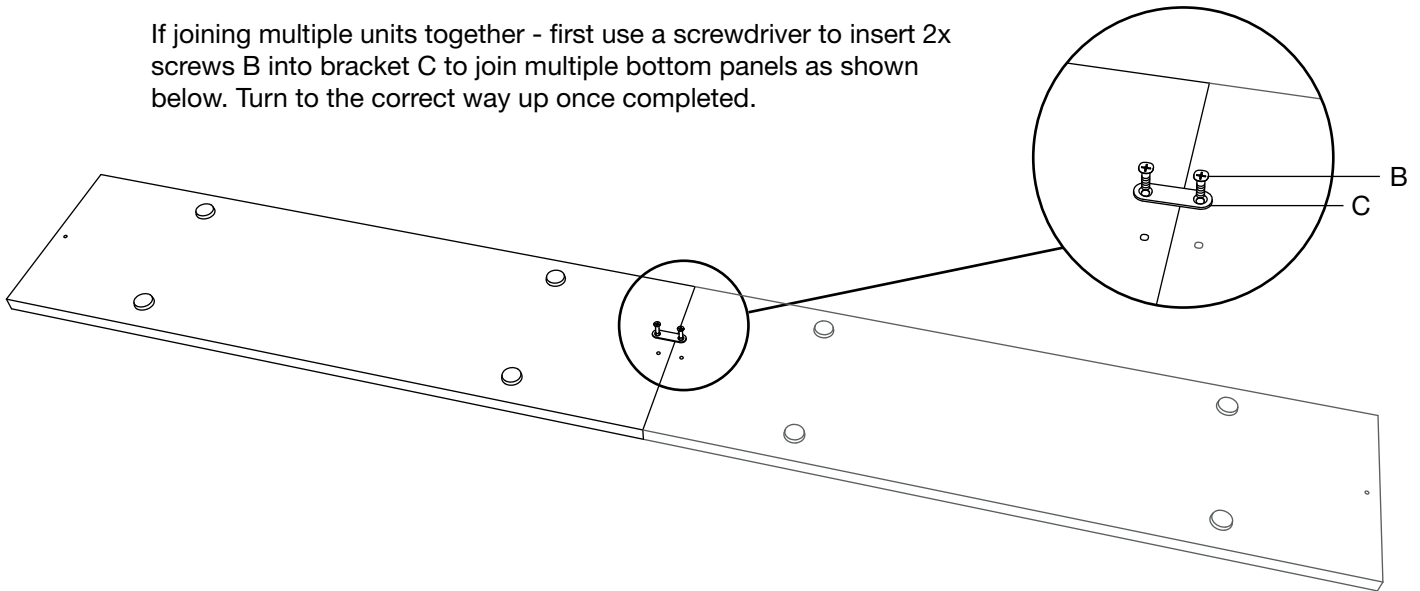





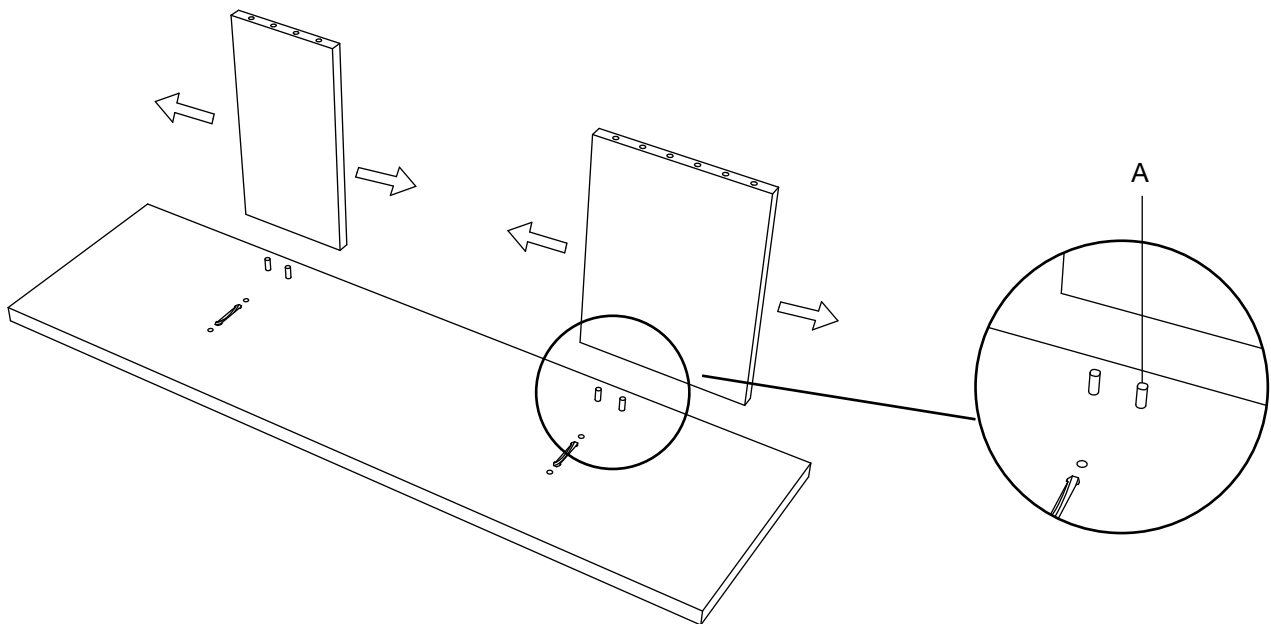

If joining multiple units together - first use a screwdriver to insert 2x screws B into bracket C to join multiple bottom panels as shown below. Turn to the correct way up once completed.

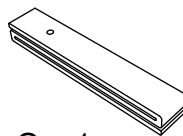

2

Insert a narrow and a wide back panel into the bottom panel using 4x dowel A. They can be interchanged and moved horizontally across different positions to create a desired visual configuration.

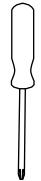

Supplied							Required	
								
A x 80	B x 4	C x 2	D x 1	E x 1	F x 2	G x 1		

3

Insert the upright partitions into the bottom shelf. There is a small and a large for each shelf. The small upright can be rotated to either run flush with the back panel or spaced away from it depending on what you prefer. Use 8x dowel A and push into position.

Fasten into position using key D turning clockwise until secure, ensuring that the holes face inwards towards each other.

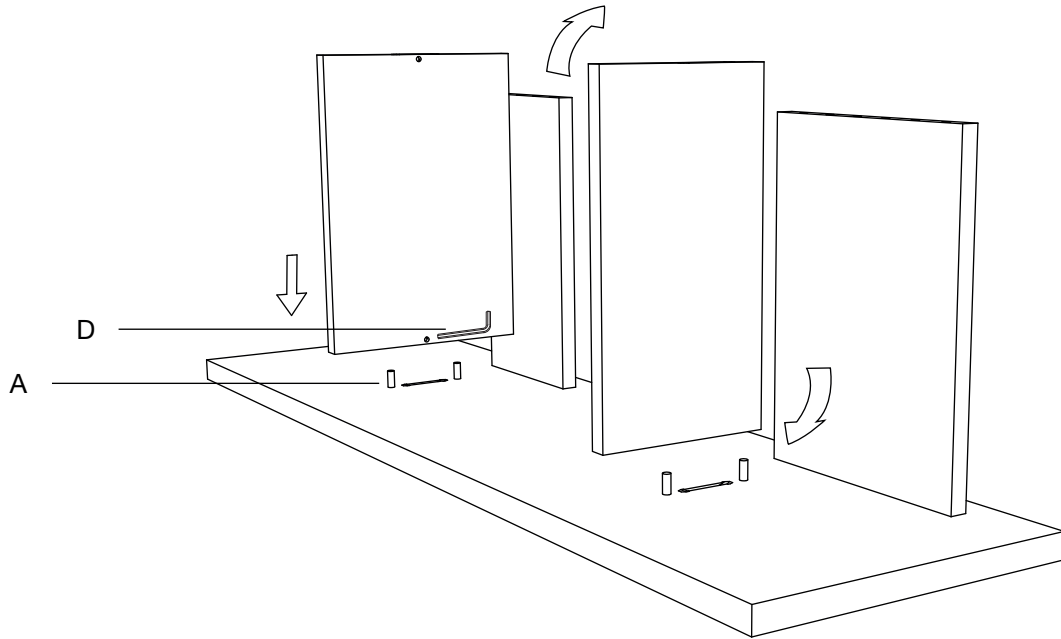

4

Add the next shelf to the existing structure using 4x dowel A and tighten using key D. Repeat steps 2 and 3 until complete. Remembering to ensure that the 3rd shelf is in its correct location.

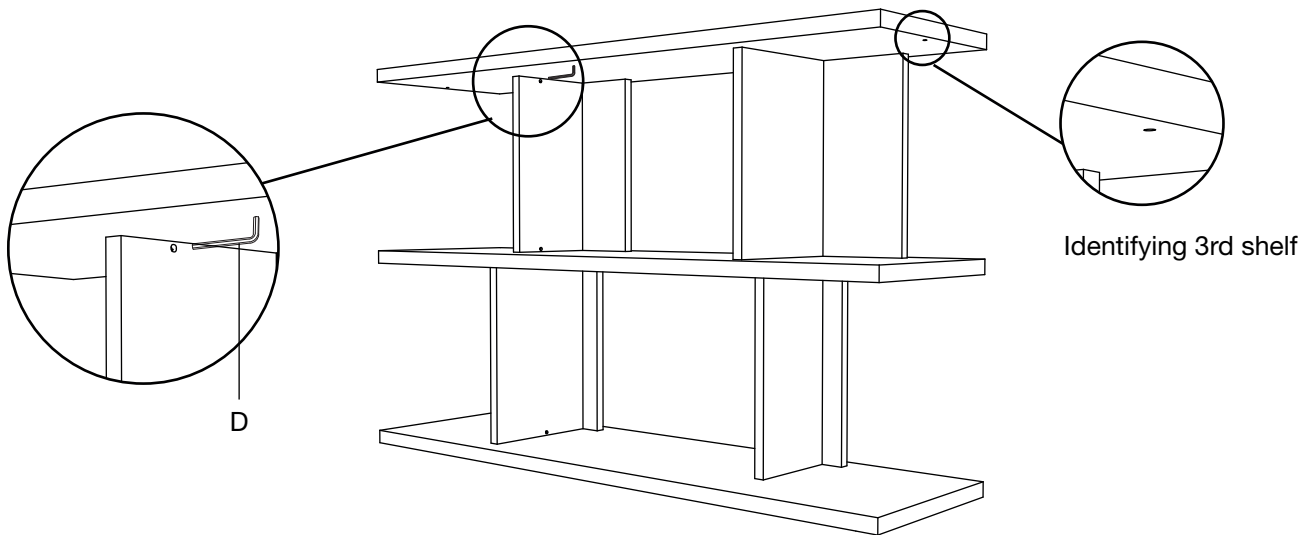

5

Once complete, if joining two or more shelves. Use a screwdriver to insert 2x screws B into bracket C, to join the underside of the 3rd shelves (top shelf on the low unit) together.

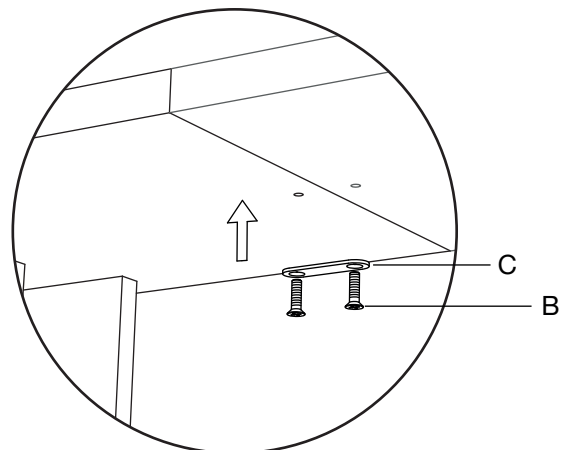

6

If required, please use 1x screw E and 1x washer F to connect wall tie G to the top shelf. The other end of the tie can then be fastened to the wall using preferred method.

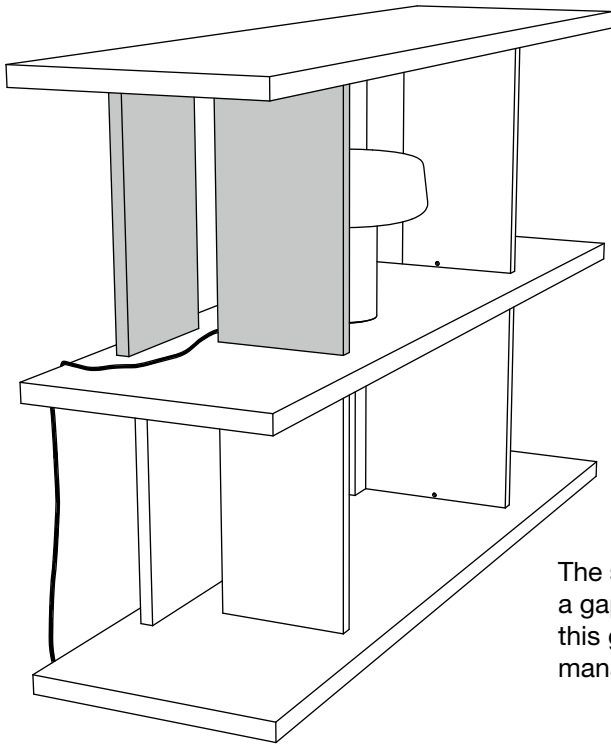

The small vertical fins can be rotated to run flush, or leave a gap against the back panels. Objects can be stored in this gap, or it can be left clear to allow for cable management.

Two units can be joined together to create further storage space.

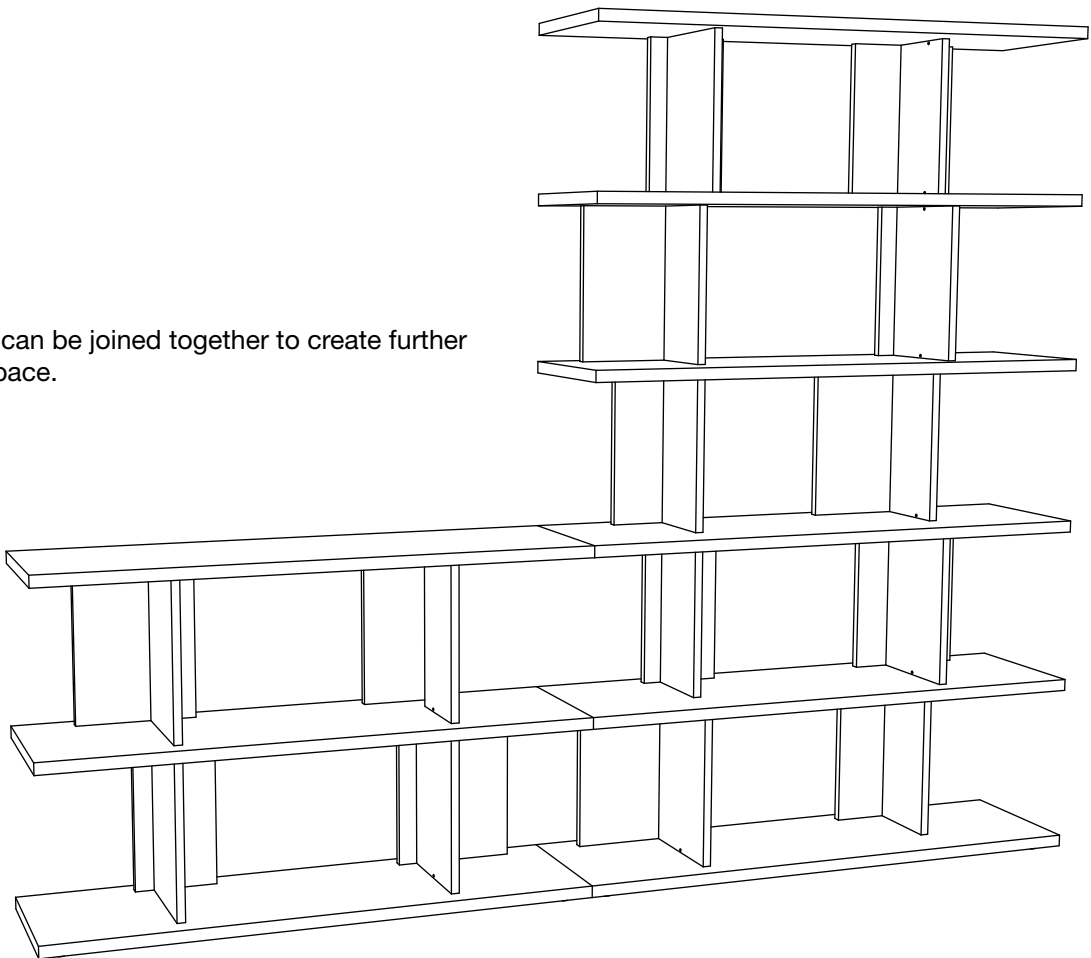

Care Instructions

Strata Low Shelving – designed by Matthew Hilton

To prolong the life of the product and retain its appearance and functionality, we would like to give you some relevant information and care advice:

This unit is manufactured using oak or walnut veneered panels.

Craftsmen manufacture this product and there is variety between each unit. This is because wood is a natural product, with natural colour and grain variations.

Natural timber is affected by sunlight; this can cause the wood colour to darken. For this reason (especially if placed in direct sunlight) it is recommended that placing objects in the same position for long periods of time is avoided. This potential colour adjustment becomes less relevant as the product ages.

It is recommended that no abrasive cleaners or solvents are used to clean the unit. Please only use proprietary furniture polishes or alternatively, warm water with a diluted mild detergent.

We thank you for purchasing this product and wish you many years of enjoyable and functional use.

For more related products please visit: casefurniture.com



Case Furniture Ltd
London, SW18 2HZ
United Kingdom

info@casefurniture.com
casefurniture.com