

DINO™ 1363/1364/1367

COFFEE & END TABLES

INSTRUCTION MANUAL

LET'S GET STARTED.

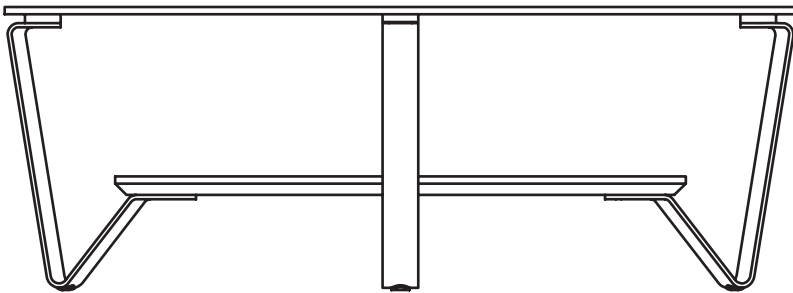

1364

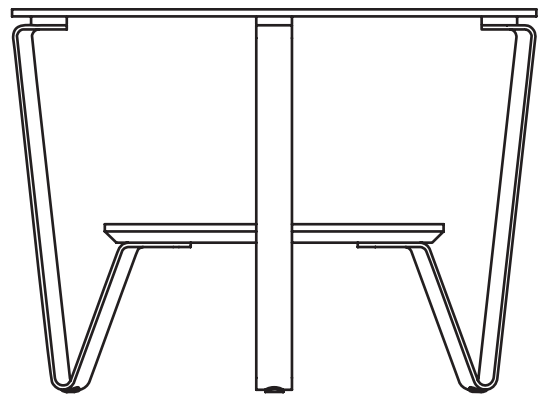

1367

DESIGN LOUIS A. LARA

BDi

BDIUSA.COM

Congratulations on the purchase of your Dino Table from BDI. Your table has been designed to provide a lifetime of enjoyment. This manual will provide assembly instructions and other helpful information to ensure you get the most out of your product. Please save it for future reference.

Your Dino Table has been engineered for simple assembly. Please follow these directions carefully to prevent any damage.

Should you need further assistance, contact BDI at customerservice@bdiusa.com.

ENJOY!

HARDWARE AND COMPONENTS

Unpack and identify the parts listed below. The assembly workspace should be a non-marring surface such as carpet. Do not use power tools for assembly of this product.

For missing hardware pieces, please contact BDI Customer Service at customerservice@bdiusa.com. For all other concerns, please contact your BDI retailer.

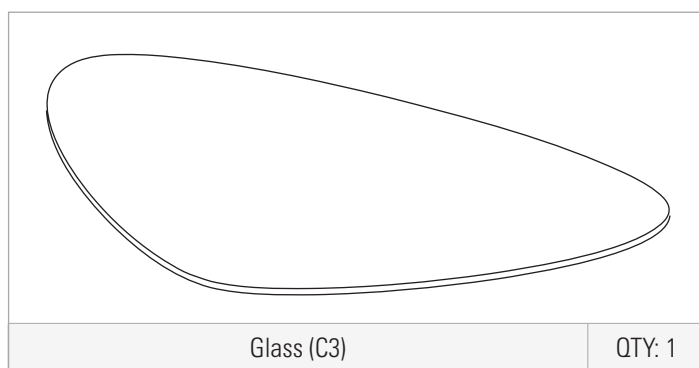
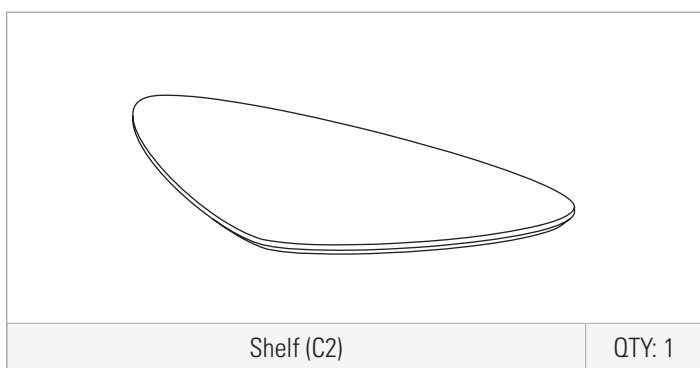
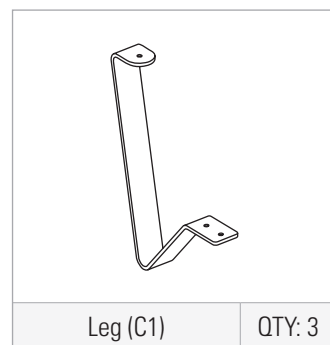
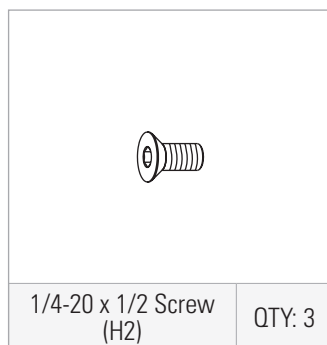
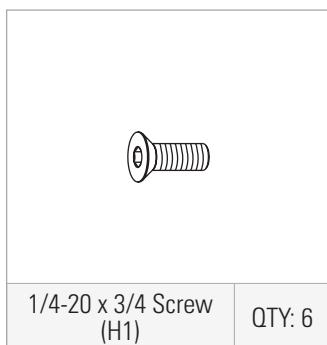
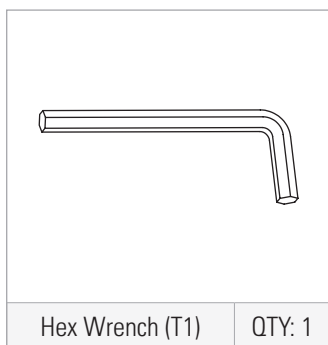

STEP 1. ATTACH LEGS TO SHELF

ASSEMBLY

Place long edge of **Shelf (C2)** on soft surface in order to prevent damage. Attach first **Leg (C1)** to middle point of **Shelf (C2)** using **Screws (H1)** and tighten using **Hex Wrench (T1)**. Attach remaining two **Legs (C1)** to **Shelf (C2)** using **Screws (H1)** and tighten using **Hex Wrench (T1)**.

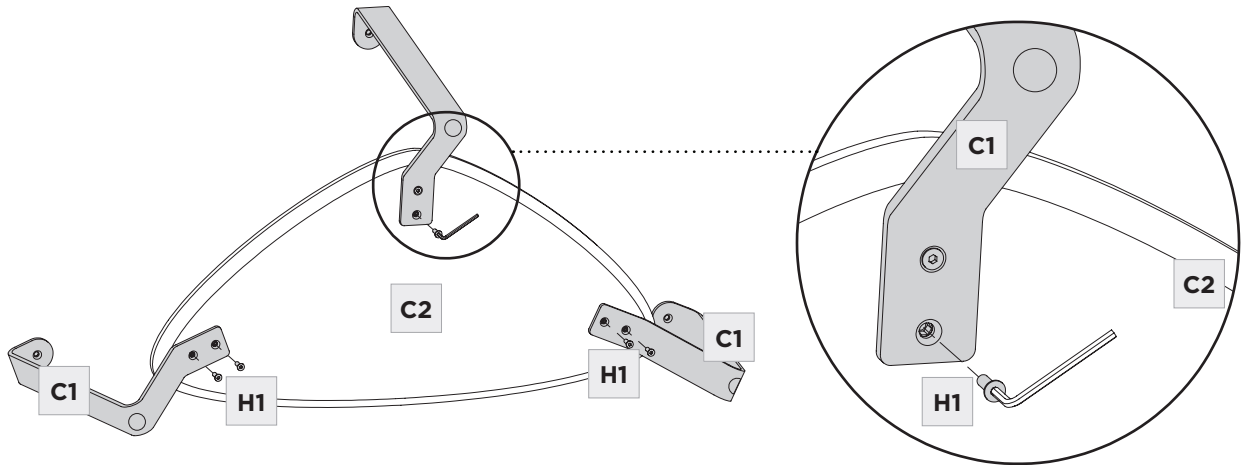

	HEX WRENCH – T1	QTY 1
	SCREW – H1	QTY 6



STEP 2. ATTACH GLASS TO LEGS

ASSEMBLY

Turn table up onto legs. Place **Glass (C3)** onto **Legs (C1)**. Loosely start all **Screws (H2)** into Glass Fittings. After all **Screws (H2)** are started, then tighten **Screws (H2)** using **Hex Wrench (T1)**.

	HEX WRENCH – T1	QTY 1
	SCREW – H2	QTY 3

