

CORA™ 1172

COFFEE TABLE

INSTRUCTION MANUAL

LET'S GET STARTED.

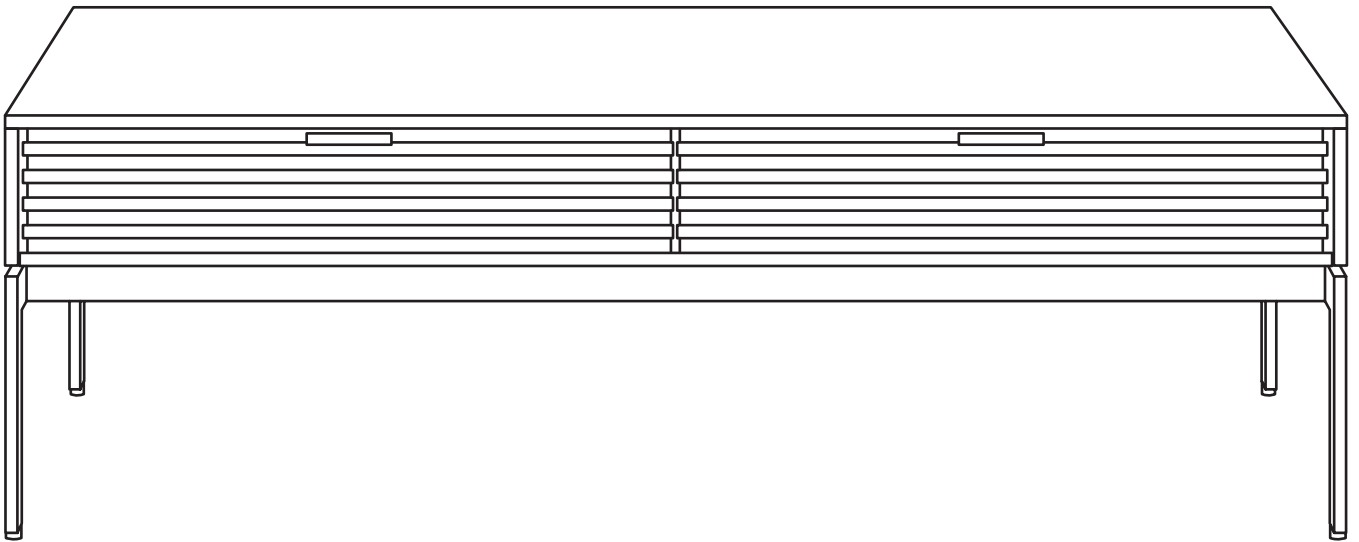

DESIGN MATTHEW WEATHERLY

BDi

BDIUSA.COM



Congratulations on the purchase of your Cora Coffee Table from BDI. Your coffee table has been designed to provide a lifetime of enjoyment. This manual will provide assembly instructions and other helpful information to ensure you get the most out of your product. Please save it for future reference.

Your Cora Coffee Table has been engineered for simple assembly. Please follow these directions carefully to prevent any damage.

Should you need further assistance, contact BDI at customerservice@bdiusa.com.

ENJOY!

HARDWARE AND COMPONENTS

Unpack and identify the parts listed below. The assembly workspace should be a non-marring surface, such as carpet. For missing hardware pieces, please contact BDI Customer Service at customerservice@bdiusa.com. For all other concerns, please contact your BDI retailer.

Do not use power tools for the assembly of this product.



TOOL REQUIRED (NOT INCLUDED)

Phillips Screwdriver



Hex Wrench (T1)

QTY: 1



Screw M6 x 16 (H1)

QTY: 8



Screw M6 x 10 (H2)

QTY: 8

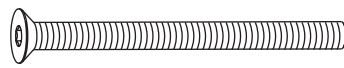

Screw M6 x 70 (H3)

QTY: 8



Wood Screw (H4)

QTY: 4

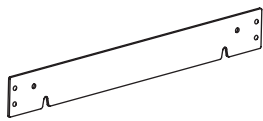

Connection Plate (C1)

QTY: 2

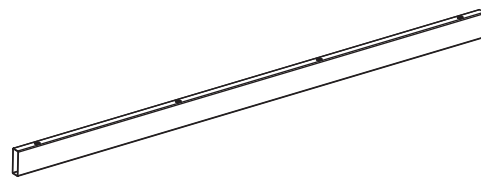

Spanner Tube (C2)

QTY: 2

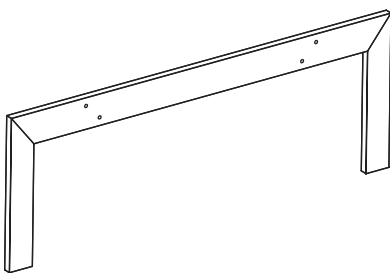

Leg (C3)

QTY: 2

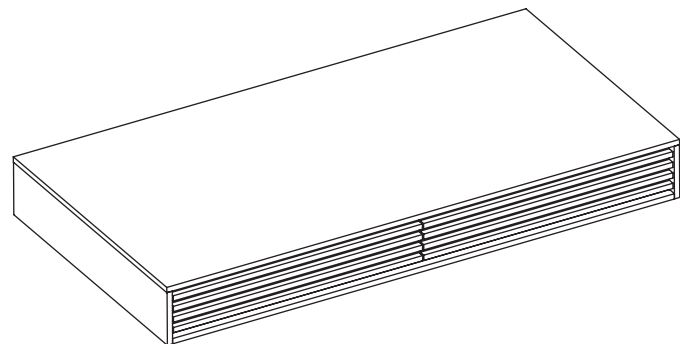

Coffee Table Case (C4)

QTY: 1

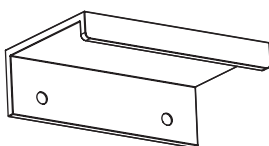



Drawer Pull (C5)

QTY: 2

STEP 1. CREATE BASE

ASSEMBLY

Attach the **Connection Plates (C1)** to the **Spanner Tubes (C2)** using **8 Screws (H1)**. Ensure that the **open slots** in the **Connection Plates** are **facing up**. Tighten with **Hex Wrench (T1)**.

	HEX WRENCH – T1	QTY 1
	SCREW – H1	QTY 8

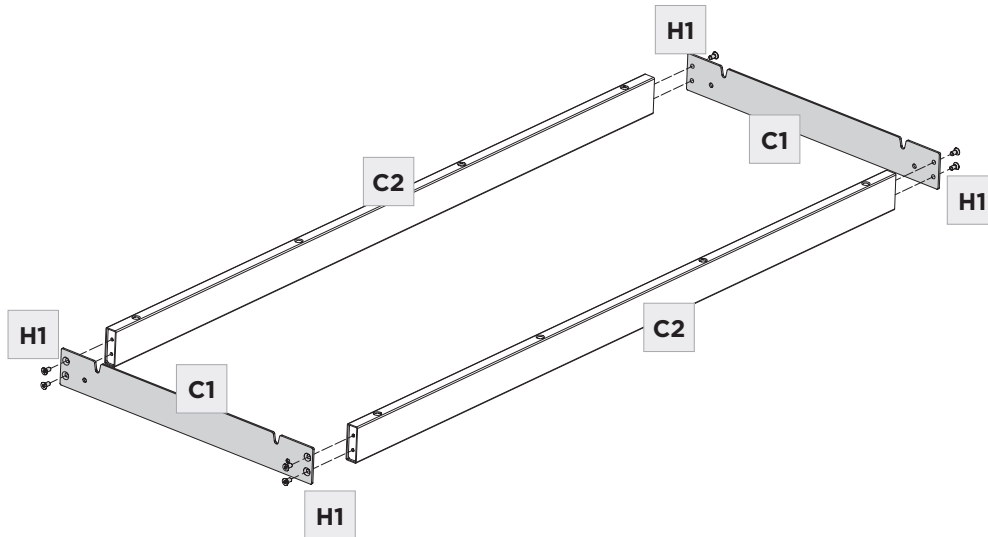

STEP 2. PREPARE LEGS

ASSEMBLY

Partially thread **2 Screws (H2)** into the lower, closer together set of holes in the cross bar of each **Leg (C3)** as shown.

Leave at least 1/4" (6mm) gap between the head of the screw and the leg.

	SCREW – H2	QTY 4
---	------------	----------

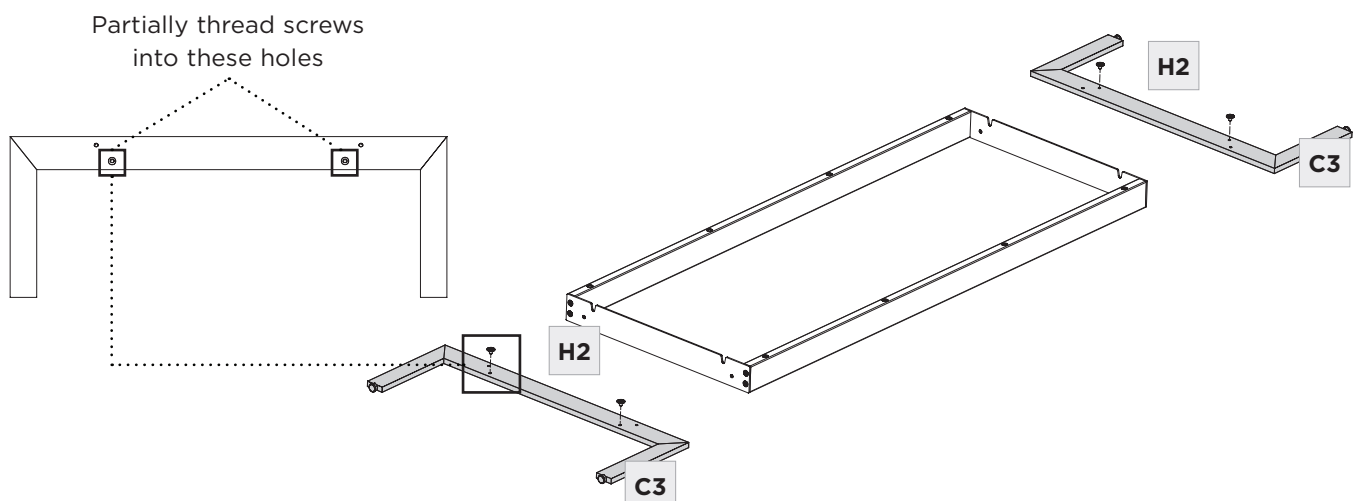

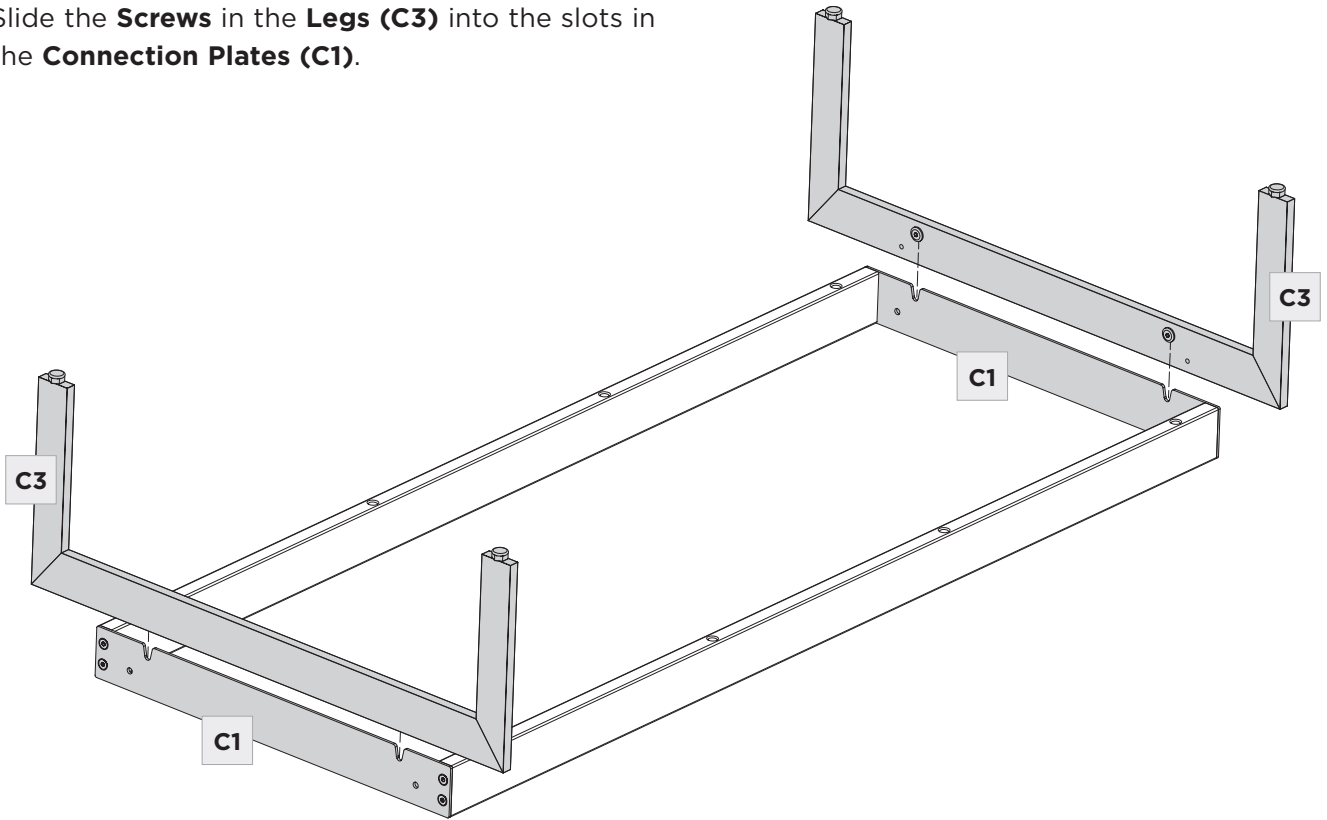

Slide the **Screws** in the **Legs (C3)** into the slots in the **Connection Plates (C1)**.



Thread the remaining **4 Screws (H2)** into the holes in the **Legs (C3)**.

Tighten all screws with **Hex Wrench (T1)**.

	HEX WRENCH – T1	QTY 1
	SCREW – H2	QTY 4

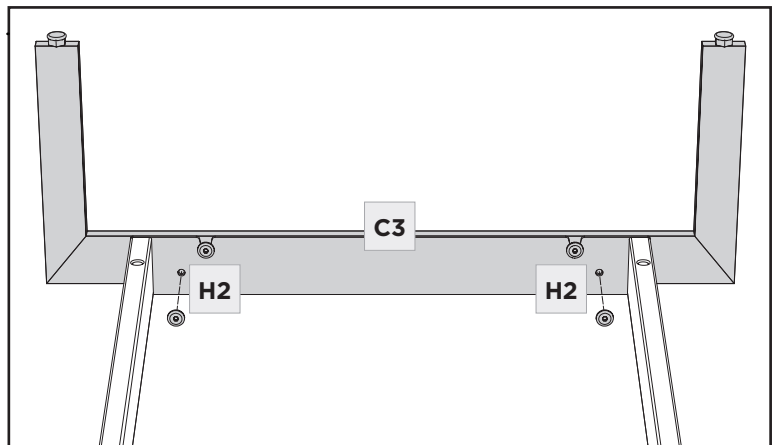
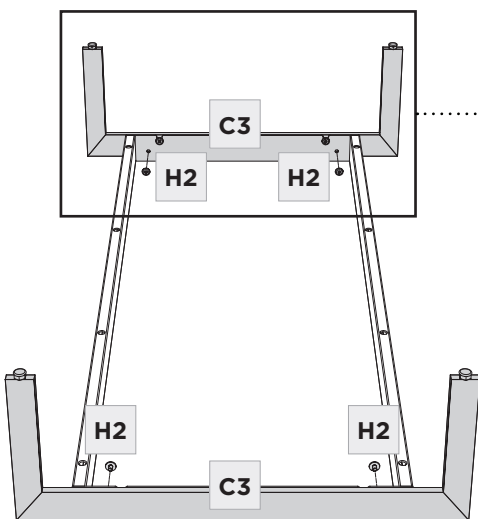

STEP 4. ATTACH BASE ASSEMBLY TO COFFEE TABLE CASE

ASSEMBLY

	HEX WRENCH – T1	QTY 1
	SCREW – H3	QTY 8

Attach the **Base Assembly** to the **Coffee Table Case (C4)** with **Screws (H3)**. Tighten with **Hex Wrench (T1)**.

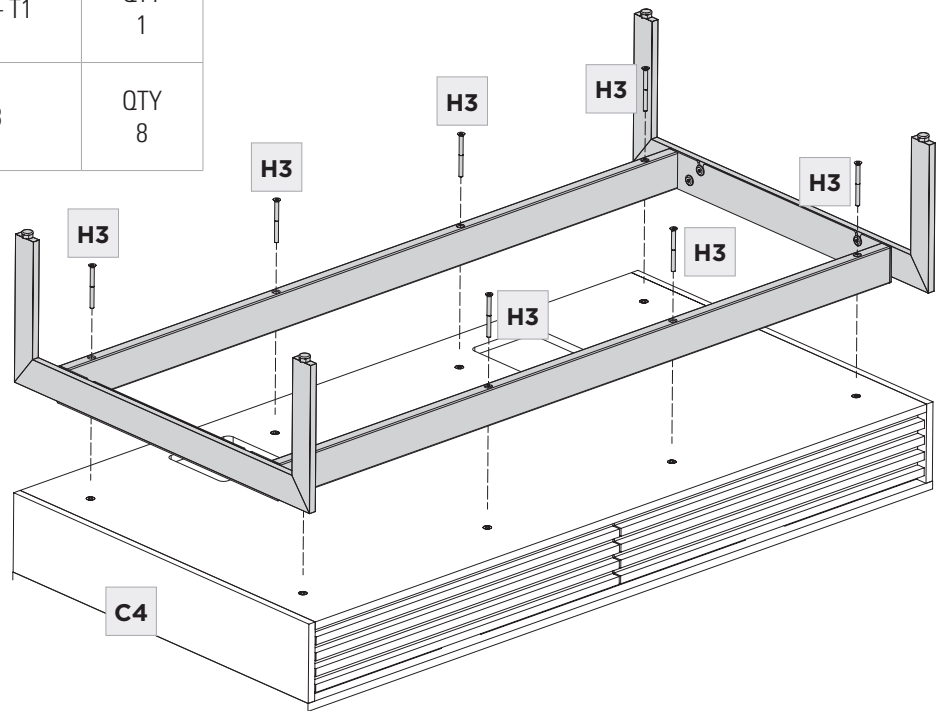



STEP 5. INSTALL DRAWER PULLS

ASSEMBLY

With help from another person, carefully flip the table onto its base. Open the drawers and install the **2 Drawer Pulls (C5)** using **4 Wood Screws (H4)**.

Tighten with **Phillips Head Screwdriver (not included)**.

	NOT INCLUDED PHILLIPS SCREWDRIVER	QTY 1
	WOOD SCREW – H4	QTY 4

