

WARNING

**DISCONNECT POWER BEFORE RELAMPING OR WIRING THE FIXTURE
READ ALL INSTRUCTIONS COMPLETELY BEFORE STARTING INSTALLATION.**

CAUTION

- **TO AVOID THE RISK OF FIRE OR SHOCK, FIXTURE MUST BE INSTALLED IN COMPLIANCE WITH ALL APPLICABLE NATIONAL AND LOCAL ELECTRICAL/BUILDING CODES.**
- **INSTALLATION AND MAINTENANCE OF THIS UNIT REQUIRES AN ELECTRICIAN OR CERTIFIED FACTORY TRAINED TECHNICIAN.**
- **If an existing fixture is being replaced, remove it and note to which of the wires in the outlet box the fixture was attached. DO NOT SEPARATE ANY OTHER WIRES THAT MAY BE IN THE BOX. DO NOT DAMAGE THE INSULATION OF OLDER WIRING. In regular circumstances the BLACK wire will be the "Hot" lead and the WHITE wire will be the "Neutral" or "Common" lead A GREEN or BARE COPPER wire is the "Ground". In older buildings it is always good practice to reconfirm the polarity of the wiring.**

NOTICE

- **The important safeguards and instructions outlined on this sheet cannot cover all possible conditions and situations that may occur. It must be understood that common sense, caution and care factors that cannot be built into any product. Caution and care must be supplied by the person(s) installing, operating and caring of this lighting fixture.**
- **This fixture is design to be mounted on a correctly installed standard round or octagon box or a through wiring box with a plaster frame. The box must be securely mounted to the structure of the building. The crossbar and hardware supplied should be used. Directly mounting the fixture to the outlet box may make it impossible to correctly align the fixture.**

FIXTURE PREPARATION

1. Remove the fixture and parts bag(s) from the carton.

NOTICE:
Before discarding the carton,
double check to make certain that all parts are found.

FIXTURE INSTALLATION

1. Insert the aircraft cable into the cable grip post of the canopy. Push the tab down on the cable grip and feed the aircraft cable. Repeat this step until you have insert all aircraft cable. (Refer Figure-1)
2. Insert the SVT wire to bushing. (Refer Figure-1)

NOTE:
Insure the height of aircraft cable and SVT wire would be sufficient as you hang the fixture

3. To change the drop height based on your desired height, push the tab down on the grip post either pull or push the aircraft cable. Repeat this to all aircraft cable until the fixture is level and with the desired height. (Refer to Figure-3)
4. Adjust the SVT wire base on the desired height. Pull/push the SVT wire to the bushing and leave 8" lead and ground wire above the canopy and cut the excess wire. (Refer to Figure-3)

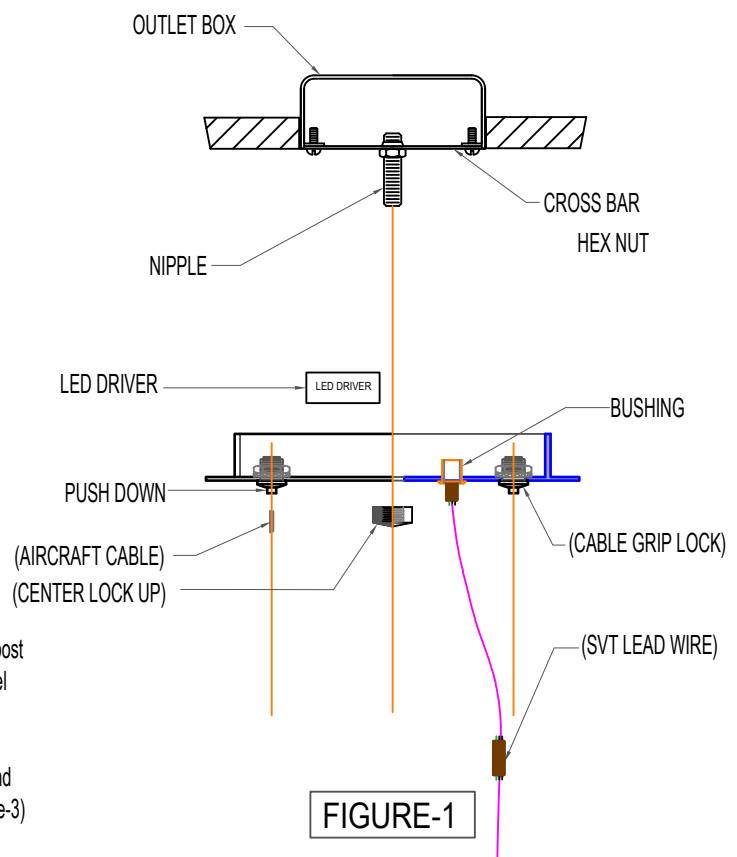

5. Place the led driver on the top of canopy and start wiring the fixture. Connect by fastening the black wire (-) coming from the fixture into the led driver where as blue wire (-) indicated. (Refer to the figure 2)

6. fasten the white wire (+) coming from the fixture into the led driver where as red wire (+)

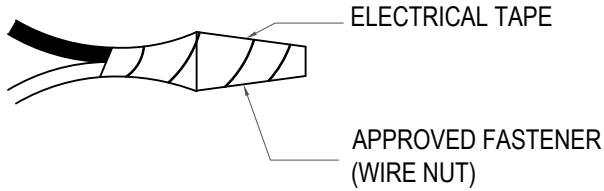

WARNING
DO NOT EXCEED RECOMMENDED WATTAGE!

NOTICE:
Must use a incandescent dimmer with LED's on this fixture.
*Lutron Maestro dimmer not compatible.

WARNING
Never fasten the ground wire to the black or "hot" wire! Failure to follow this instruction could result in serious injury or death!

WARNING
Make sure that there is no exposed wire or strands that could cause a dangerous short circuit!

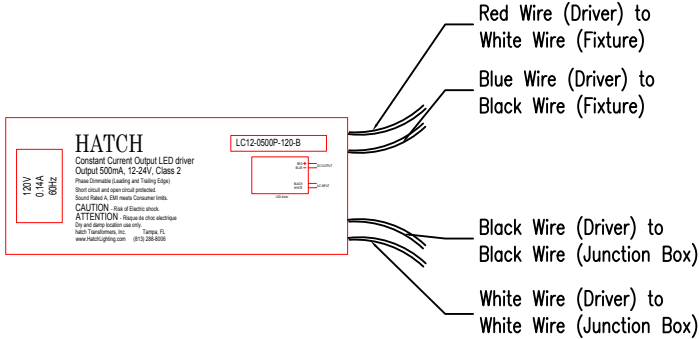

7. Attach the cross bar to the outlet box using the mounting screws. (Refer Figure-1).

8. Fasten the ground wire to the green or bare copper wire in the outlet box (if outlet box is plastic) or to the green screw on the cross bar.

9. Fasten the white wire from the junction box into the led driver where as white wire indicated (AC Input) (Refer Figure-2)

10. Fasten the black wire from the junction box into the led driver where as black wire indicated (AC Input). (Refer Figure-2)

NOTE:
Need another person that will hold the fixture during installation.

11. Thread the hex nut onto the nipple and the nipple into the cross bar . Place the canopy over the nipple and against the ceiling. Adjust the nipple so that 1/2" of threads extend beyond the canopy. (Refer to Figure 1)

12. Using the center lock up, loosely fasten the fixture to the outlet box. Adjust the orientation of the fixture. Refer to step 3 and 4 and Figure 3.

13. Once the required orientation met, tighten the center lock. Refer to Figure 1 & 3.

SEE ALSO DRIVER COLOR CODING
LED LAMP TO LED DRIVER
WIRE CONNECTION DETAILS

FIGURE-2

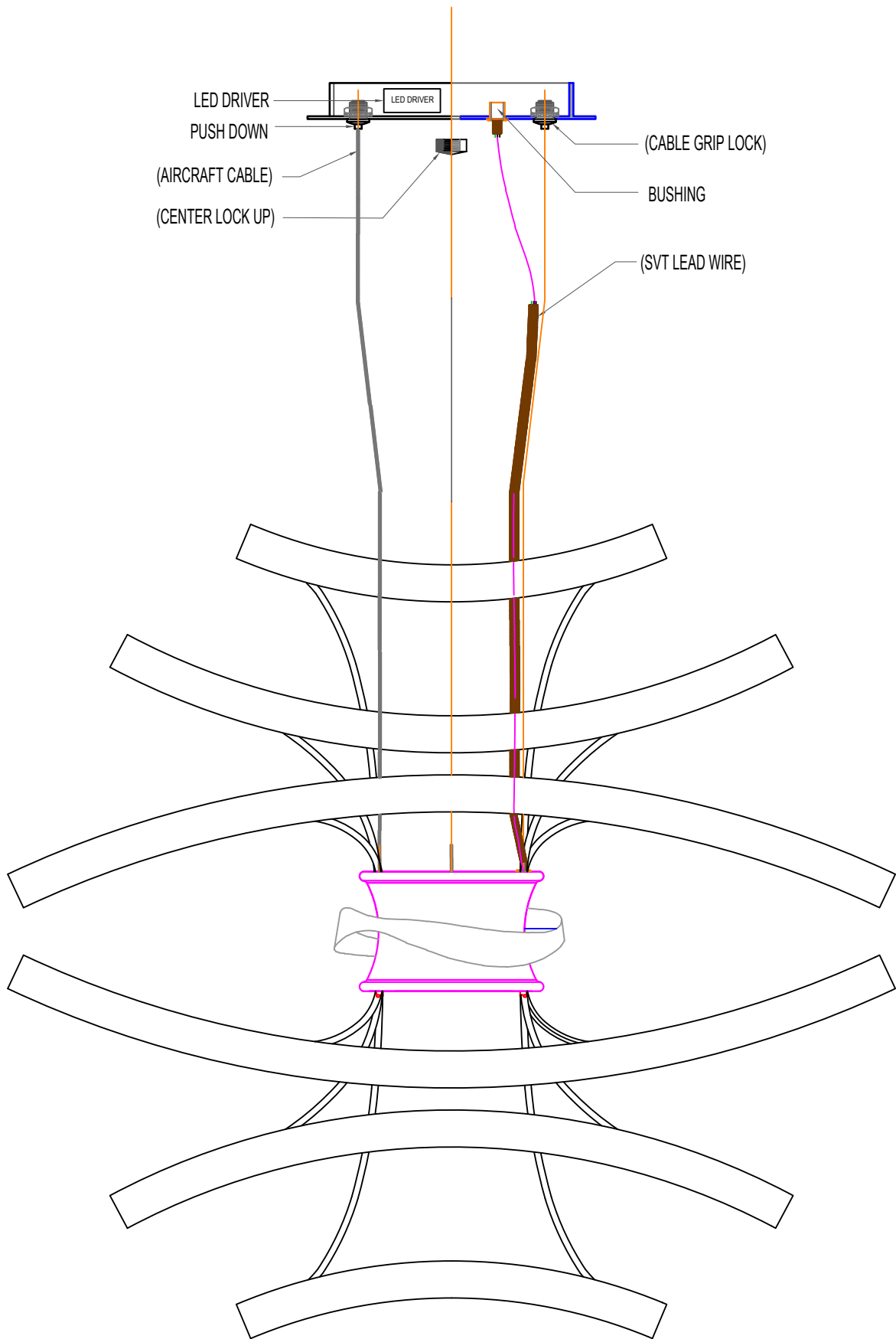

FIGURE-3

FIXTURE REASSEMBLY

NOTE:

Fixture should be reassemble prior to installation.

1. Identify Fixture A, Remove the protective cover on the LED Light on the bottom portion.
2. Identify Fixture B, place the glass on the top of fixture. Refer to Figure-3.
3. Attach Fixture B to Fixture A using the provided bolt. Use the appropriate tool in tightening the bolt. Refer to Figure 3.

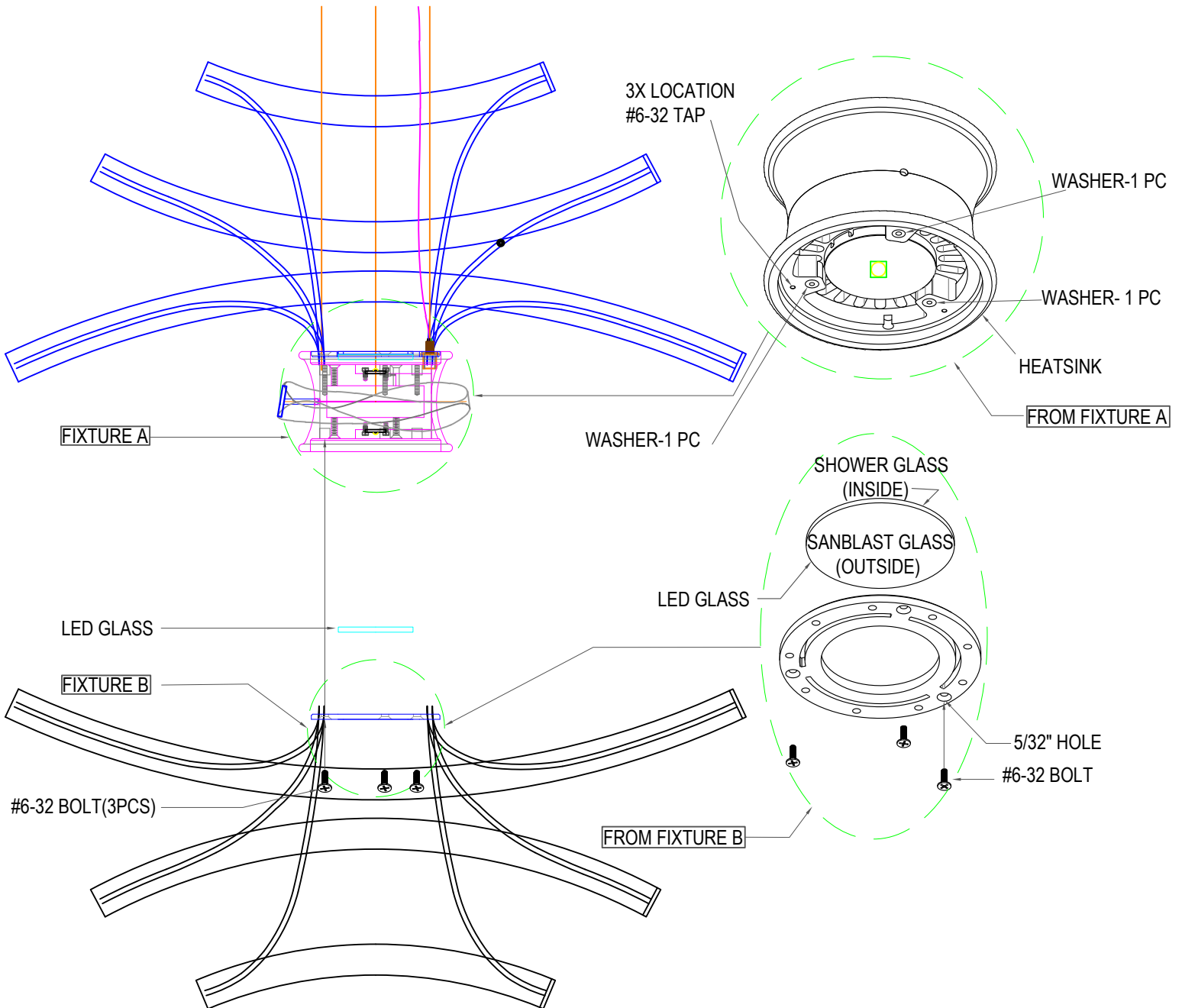

FIGURE- 4

14. Restore power to circuit at breaker or fuse box.

⚠ WARNING

**DISCONNECT POWER BEFORE RELAMPING OR WIRING THE FIXTURE
READ ALL INSTRUCTIONS COMPLETELY BEFORE STARTING INSTALLATION.**

⚠ CAUTION

- **TO AVOID THE RISK OF FIRE OR SHOCK, FIXTURE MUST BE INSTALLED IN COMPLIANCE WITH ALL APPLICABLE NATIONAL AND LOCAL ELECTRICAL/BUILDING CODES.**
- **INSTALLATION AND MAINTENANCE OF THIS UNIT REQUIRES AN ELECTRICIAN OR CERTIFIED FACTORY TRAINED TECHNICIAN.**
- **If an existing fixture is being replaced, remove it and note to which of the wires in the outlet box the fixture was attached. DO NOT SEPARATE ANY OTHER WIRES THAT MAY BE IN THE BOX. DO NOT DAMAGE THE INSULATION OF OLDER WIRING. In regular circumstances the BLACK wire will be the "Hot" lead and the WHITE wire will be the "Neutral" or "Common" lead. A GREEN or BARE COPPER wire is the "Ground". In older buildings it is always good practice to reconfirm the polarity of the wiring.**

NOTICE

- **The important safeguards and instructions outlined on this sheet cannot cover all possible conditions and situations that may occur. It must be understood that common sense, caution and care factors that cannot be built into any product. Caution and care must be supplied by the person(s) installing, operating and caring of this lighting fixture.**
- **This fixture is design to be mounted on a correctly installed standard round or octagon box or a through wiring box with a plaster frame. The box must be securely mounted to the structure of the building. The crossbar and hardware supplied should be used. Directly mounting the fixture to the outlet box may make it impossible to correctly align the fixture.**

FIXTURE PREPARATION

1. Remove the fixture and parts bag(s) from the carton.

NOTICE:

Before discarding the carton, double check to make certain that all parts are found.

FIXTURE INSTALLATION

1. Insert the aircraft cable into the cable grip post of the canopy. Push the tab down on the cable grip and feed the aircraft cable. Repeat this step until you have insert all aircraft cable. (Refer Figure-1)
 2. Insert the SVT wire to bushing. (Refer Figure-1)
- NOTE:**
Insure the height of aircraft cable and SVT wire would be sufficient as you hang the fixture
3. To change the drop height based on your desired height, push the tab down on the grip post either pull or push the aircraft cable. Repeat this to all aircraft cable until the fixture is level and with the desired height. (Refer to Figure-4)
 4. Adjust the SVT wire base on the desired height. Pull/push the SVT wire to the bushing and leave 8" lead and ground wire above the canopy and cut the excess wire. (Refer to Figure-4)

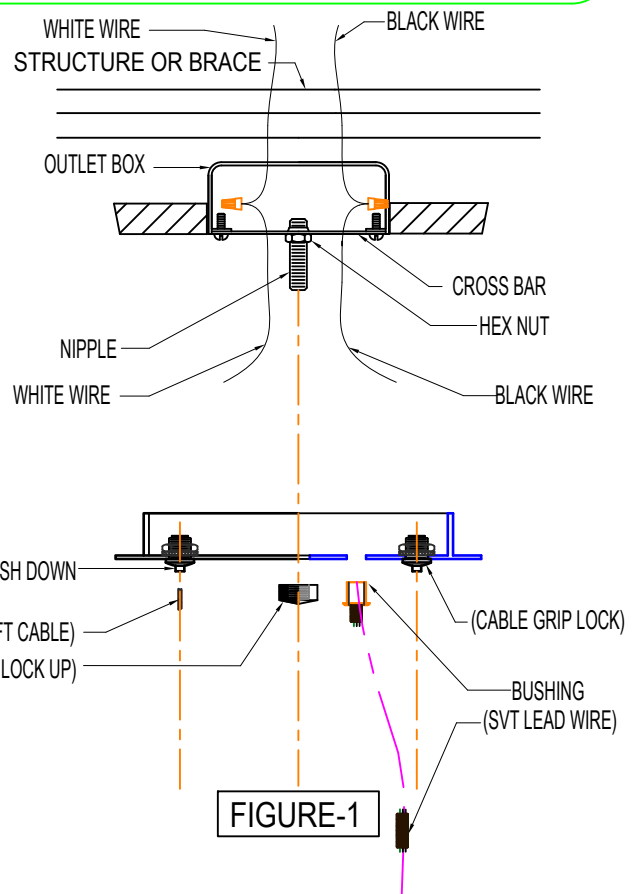

FIGURE-1

5. Attach the mounting bracket to the outlet box using the mounting screws. (Refer Figure-1).

NOTICE:
This luminaire must be mounted or supported independently of an outlet box.

NOTICE:
Must use a incandescent dimmer with LED's on this fixture.
*Lutron Maestro dimmer not compatible.

6. Fasten the ground wire to the green or bare copper wire in the outlet box (if outlet box is plastic) or to the green screw on the mounting bracket.

WARNING
Never fasten the ground wire to the black or "hot" wire! Failure to follow this instruction could result in serious injury or death!

7. Fasten the white wire of the led light to the white wire in the outlet box. Fasten the wires together with an approved fastener (wire nut). Starting about 1" below the fastener, tightly wrap the connection with electrical tape so that the connections seals the end of the fastener. (See Figure 2)

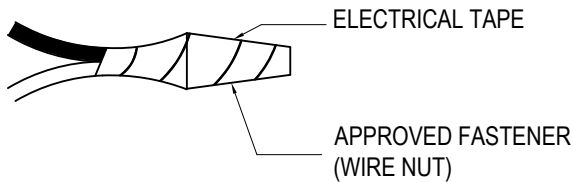

WARNING
Make sure that there is no exposed wire or strands that could cause a dangerous short circuit!

8. Connect the black wire of the led light to the black wire in the outlet box. Fasten the joined wire as in step 6.

NOTE:
LED light will be received assembled as in Replacement LED Instruction

NOTE:
Need another person that will hold the fixture during installation.

9. Thread the hex nut onto the nipple and the nipple into the mounting bracket . Place the canopy over the nipple and against the ceiling. Adjust the nipple so that 1/2" of threads extend beyond the canopy. (Refer to Figure 1)

10. Using the center lock up, loosely fasten the fixture to the outlet box. Adjust the orientation of the fixture. Refer to step 3 and 4 and Figure 4.

11. Once the required orientation met, tighten the center lock. Refer to Figure 1 & 4.

12 Restore power to circuit at breaker or fuse box.

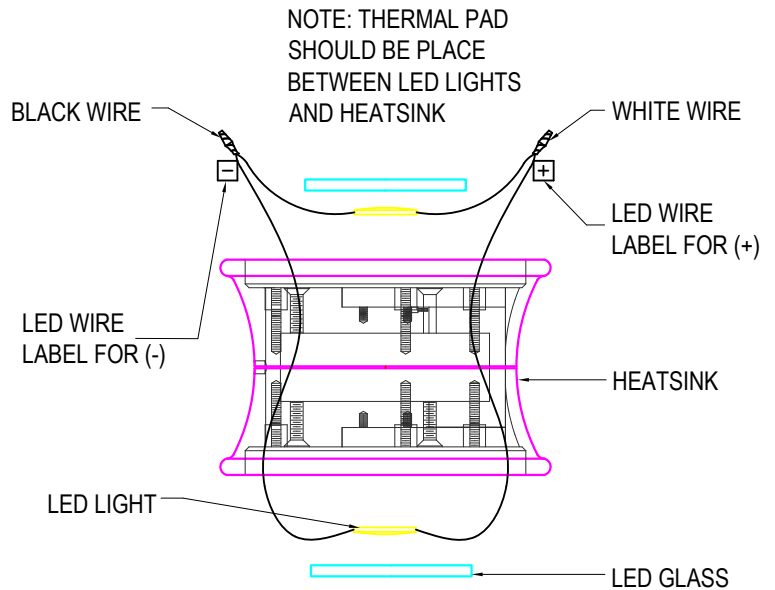

Replacement LED Instruction

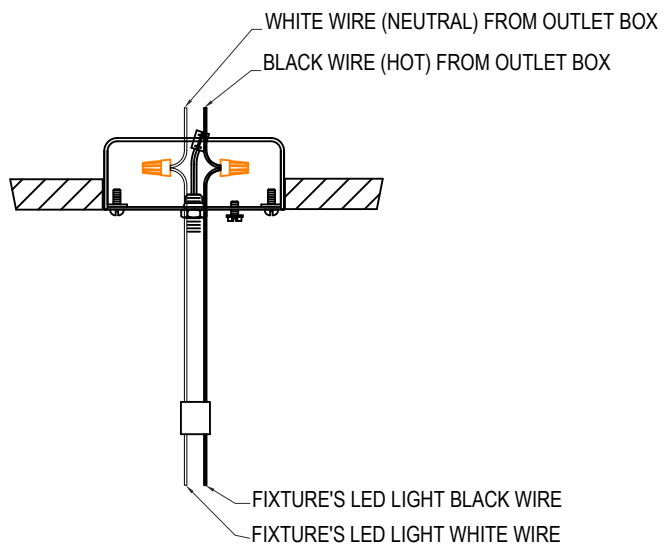

LED LIGHT TO OUTLET BOX WIRE CONNECTION DETAILS

FIGURE-2

FIXTURE REASSEMBLY

NOTE:

Fixture should be reassemble prior to installation.

1. Identify Fixture A, Remove the protective cover on the LED Light on the bottom portion.
2. Identify Fixture B, put set of washer and place the glass on the top of fixture. Refer to Figure-3.
3. Attach Fixture B to Fixture A using the provided bolt. Use the appropriate tool in tightening the bolt. Refer to Figure 3.

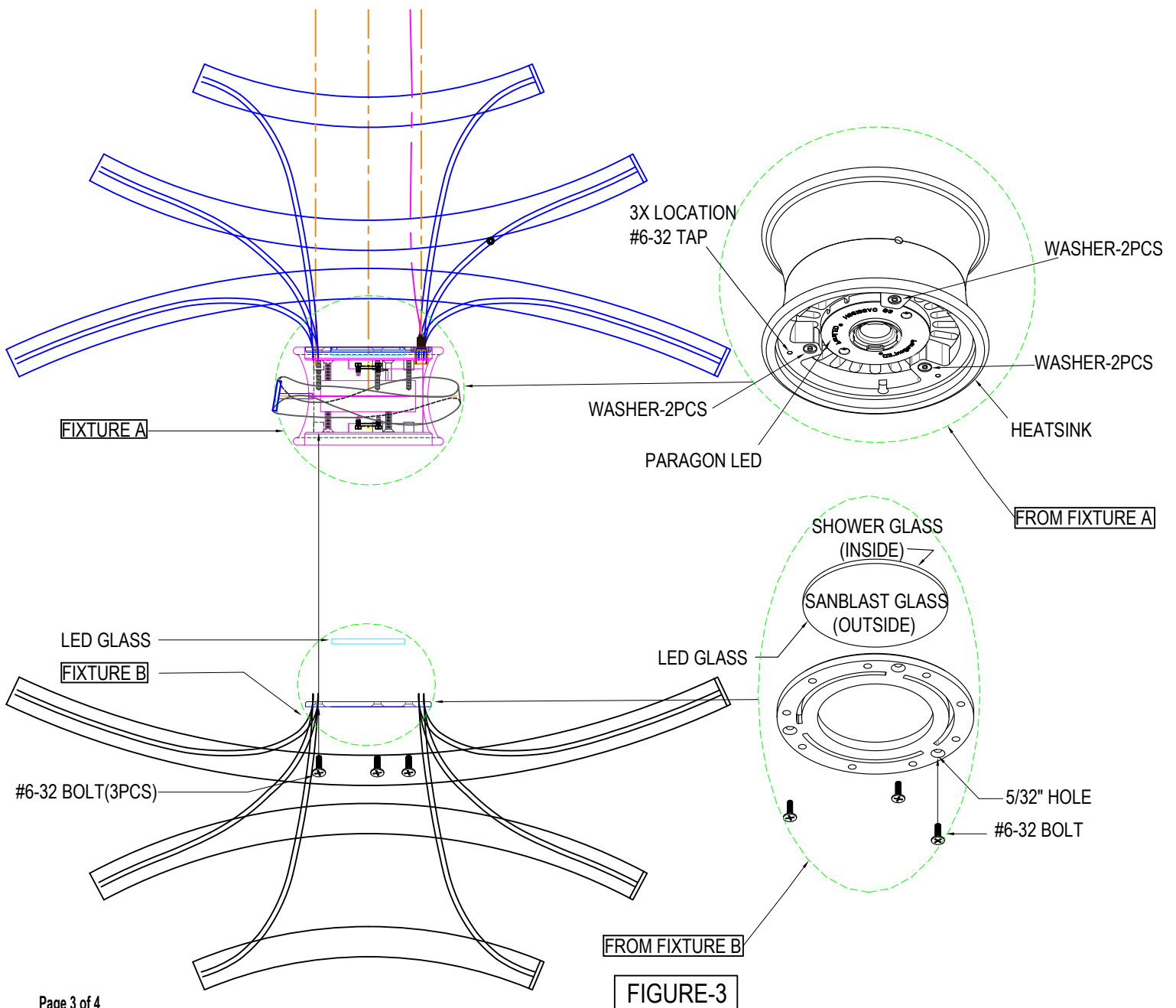

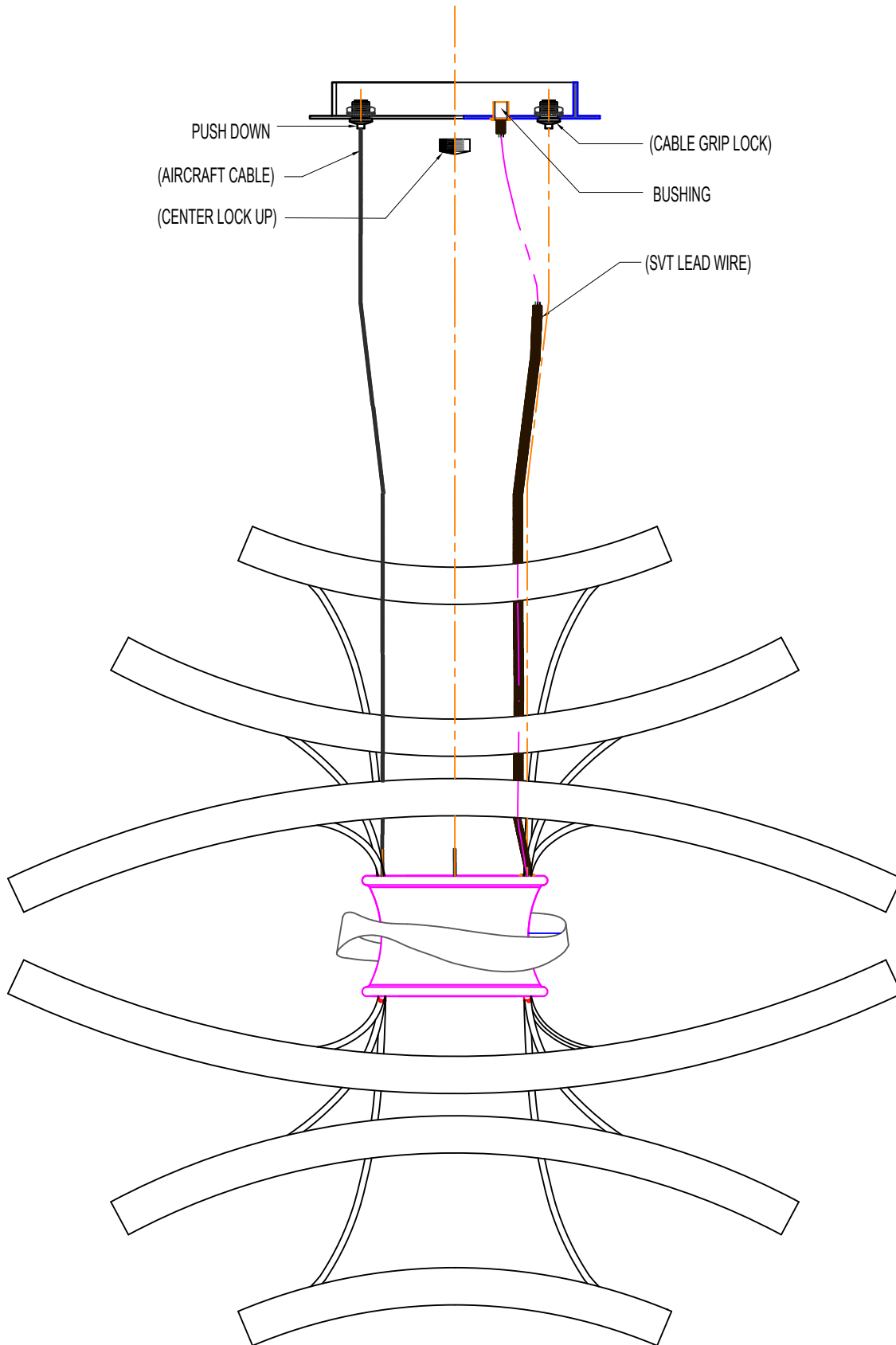

FIGURE- 4

WARNING

DISCONNECT POWER BEFORE RELAMPING OR WIRING THE FIXTURE
READ ALL INSTRUCTIONS COMPLETELY BEFORE STARTING INSTALLATION.

CAUTION

- TO AVOID THE RISK OF FIRE OR SHOCK, FIXTURE MUST BE INSTALLED IN COMPLIANCE WITH ALL APPLICABLE NATIONAL AND LOCAL ELECTRICAL/BUILDING CODES.
- INSTALLATION AND MAINTENANCE OF THIS UNIT REQUIRES AN ELECTRICIAN OR CERTIFIED FACTORY TRAINED TECHNICIAN.
- If an existing fixture is being replaced, remove it and note to which of the wires in the outlet box the fixture was attached. DO NOT SEPARATE ANY OTHER WIRES THAT MAY BE IN THE BOX. DO NOT DAMAGE THE INSULATION OF OLDER WIRING. In regular circumstances the BLACK wire will be the "Hot" lead and the WHITE wire will be the "Neutral" or "Common" lead. A GREEN or BARE COPPER wire is the "Ground". In older buildings it is always good practice to reconfirm the polarity of the wiring.

NOTICE

- The important safeguards and instructions outlined on this sheet cannot cover all possible conditions and situations that may occur. It must be understood that common sense, caution and care factors that cannot be built into any product. Caution and care must be supplied by the person(s) installing, operating and caring of this lighting fixture.
- This fixture is design to be mounted on a correctly installed standard round or octagon box or a through wiring box with a plaster frame. The box must be securely mounted to the structure of the building. The crossbar and hardware supplied should be used. Directly mounting the fixture to the outlet box may make it impossible to correctly align the fixture.

FIXTURE PREPARATION

1. Remove the fixture and parts bag(s) from the carton.

NOTICE:

Before discarding the carton, double check to make certain that all parts are found.

FIXTURE INSTALLATION

1. Insert the aircraft cable into the cable grip post of the canopy. Push the tab down on the cable grip and feed the aircraft cable. Repeat this step until you have insert all aircraft cable. (Refer Figure-1)
2. Insert the SVT wire to bushing. (Refer Figure-1)

NOTE:

Insure the height of aircraft cable and SVT wire would be sufficient as you hang the fixture

3. To change the drop height based on your desired height, push the tab down on the grip post either pull or push the aircraft cable. Repeat this to all aircraft cable until the fixture is level and with the desired height. (Refer to Figure-4)
4. Adjust the SVT wire base on the desired height. Pull/push the SVT wire to the bushing and leave 8" lead and ground wire above the canopy and cut the excess wire. (Refer to Figure-4)

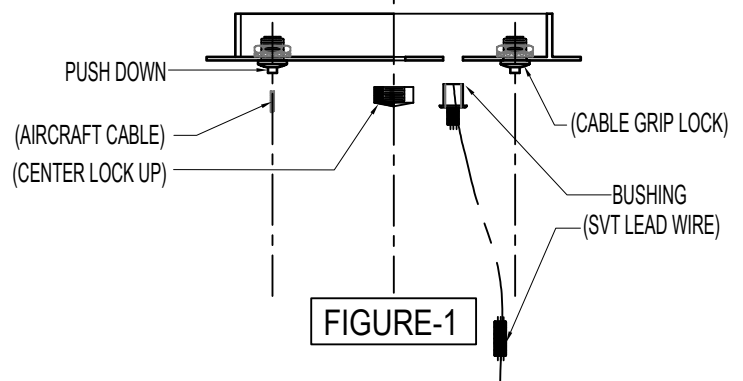
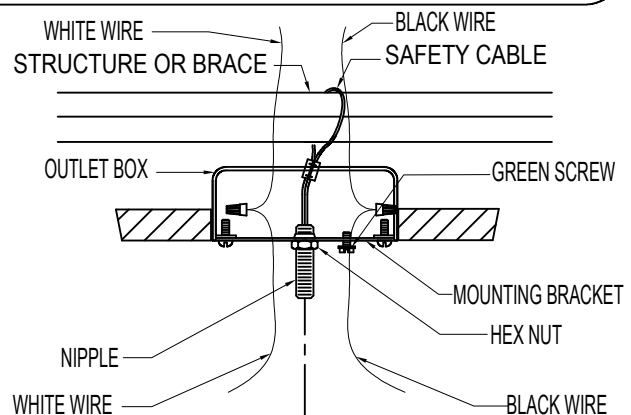

5. Attach the mounting bracket to the outlet box using the mounting screws. Attach the safety cable to the building structure or brace. (Refer Figure-1).

NOTICE:
This luminaire must be mounted or supported independently of an outlet box.

WARNING
Refer to the illustration for correct and safe installation of safety cable. Failure to follow this instruction could result harm/damage to the fixture, property and/or person(s)!

6. Fasten the ground wire to the green or bare copper wire in the outlet box (if outlet box is plastic) or to the green screw on the mounting bracket.

WARNING
Never fasten the ground wire to the black or "hot" wire! Failure to follow this instruction could result in serious injury or death!

7. Fasten the white wire of the led light to the white wire in the outlet box. Fasten the wires together with an approved fastener (wire nut). Starting about 1" below the fastener, tightly wrap the connection with electrical tape so that the connections seals the end of the fastener. (See Figure 2)

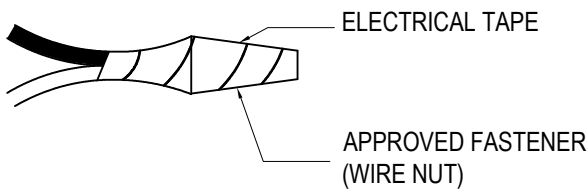

WARNING
Make sure that there is no exposed wire or strands that could cause a dangerous short circuit!

8. Connect the black wire of the led light to the black wire in the outlet box. Fasten the joined wire as in step 7.

NOTE:
LED light will be received assembled as in Replacement LED Instruction

NOTE:
Need another person that will hold the fixture during installation.

9. Thread the hex nut onto the nipple and the nipple into the mounting bracket. Place the canopy over the nipple and against the ceiling. Adjust the nipple so that 1/2" of threads extend beyond the canopy. (Refer to Figure 1)

10. Using the center lock up, loosely fasten the fixture to the outlet box. Adjust the orientation of the fixture. Refer to step 3 and 4 and Figure 4.

11. Once the required orientation met, tighten the center lock. Refer to Figure 1 & 4.

12. Restore power to circuit at breaker or fuse box.

NOTICE:
Must use a incandescent dimmer with LED's on this fixture.
*Lutron Maestro dimmer not compatible.

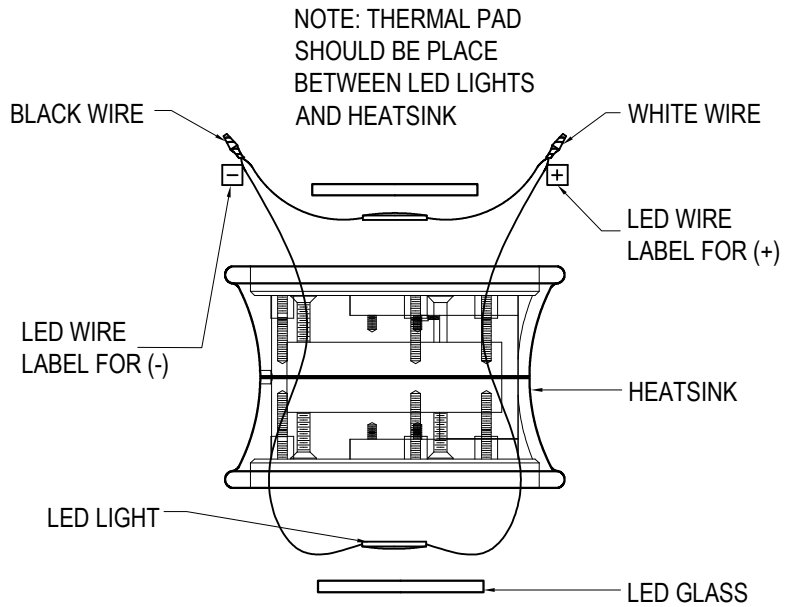

Replacement LED Instruction

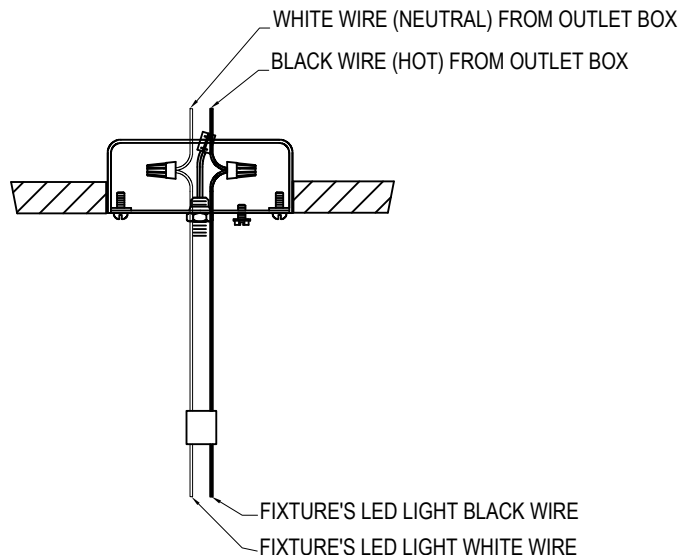

LED LIGHT TO OUTLET BOX
WIRE CONNECTION DETAILS

FIGURE-2

FIXTURE REASSEMBLY

NOTE:
Fixture should be reassemble prior to installation.

1. Identify Fixture A, Remove the protective cover on the LED Light on the bottom portion.
2. Identify Fixture B, place the glass on the top of fixture. Refer to Figure-3.
3. On top of Fixture B look for a dot sticker/marking. Align this to Fixture A wherein same marking will be seen on the bottom of the fixture. Refer to Figure-3.
4. Attach the two using the provided bolt. Use the appropriate tool in tightening the bolt. Refer to Figure 3.

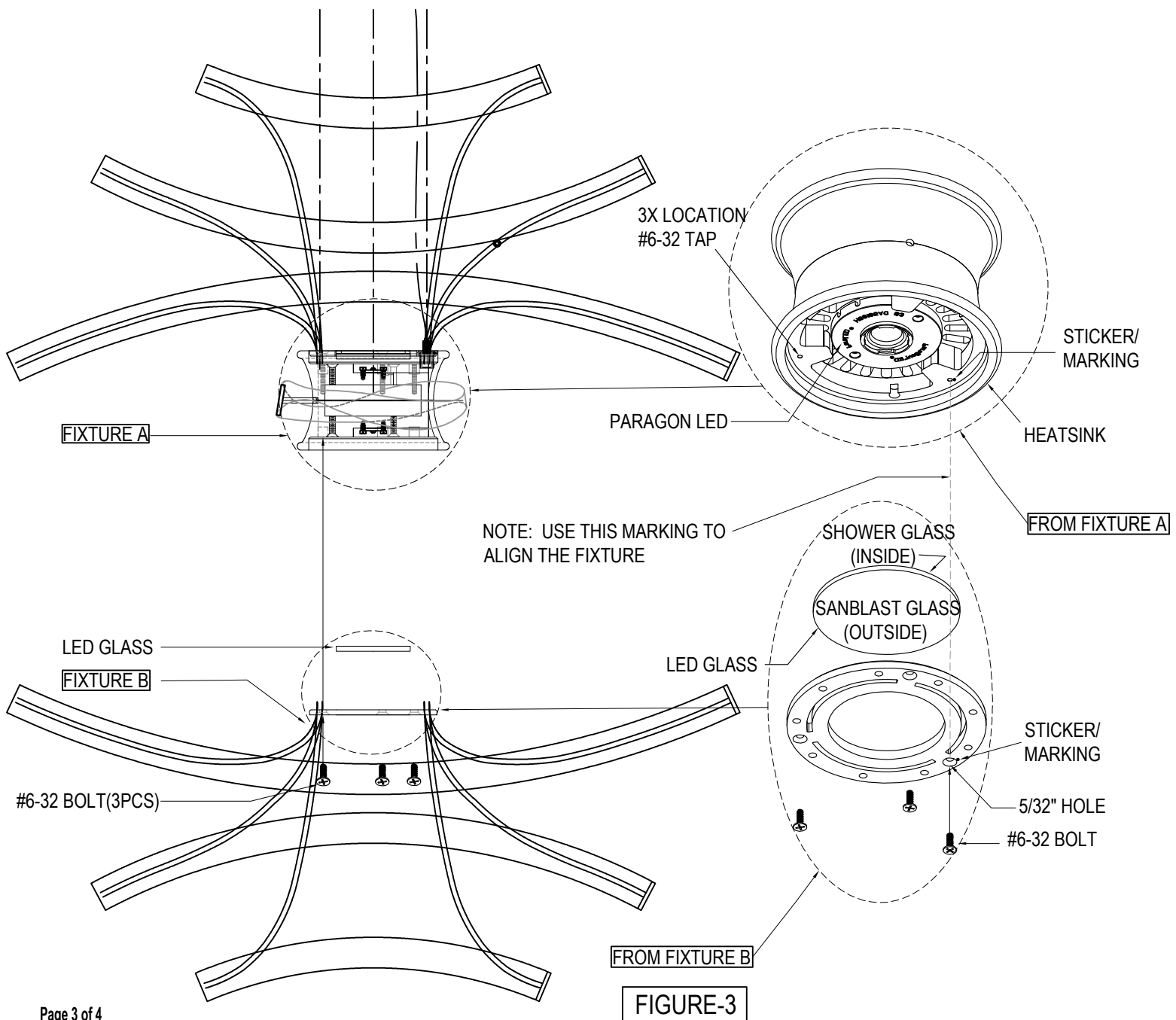

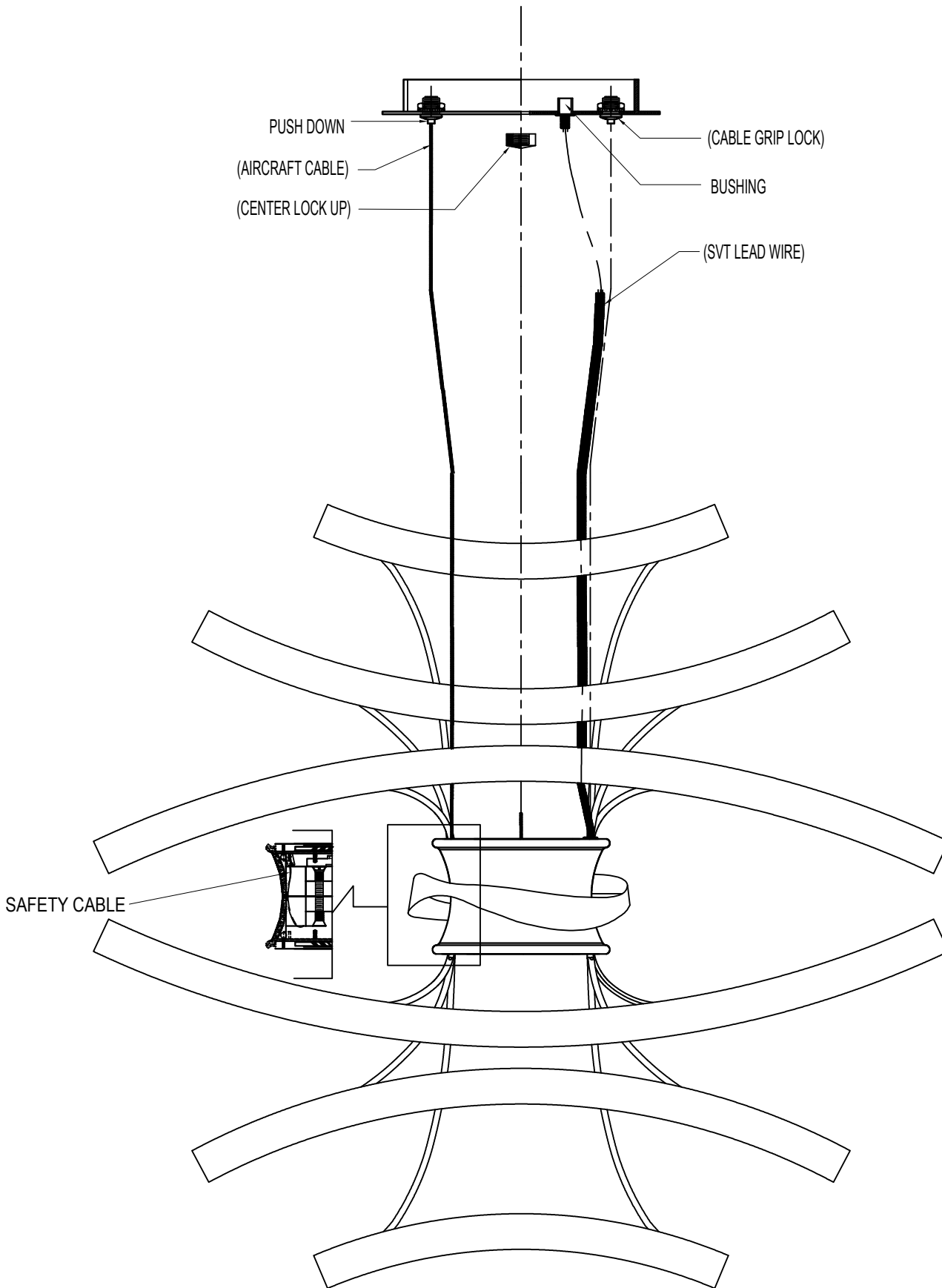

FIGURE- 4

⚠ WARNING

**DISCONNECT POWER BEFORE RELAMPING OR WIRING THE FIXTURE
READ ALL INSTRUCTIONS COMPLETELY BEFORE STARTING INSTALLATION.**

⚠ CAUTION

- TO AVOID THE RISK OF FIRE OR SHOCK, FIXTURE MUST BE INSTALLED IN COMPLIANCE WITH ALL APPLICABLE NATIONAL AND LOCAL ELECTRICAL/BUILDING CODES.
- INSTALLATION AND MAINTENANCE OF THIS UNIT REQUIRES AN ELECTRICIAN OR CERTIFIED FACTORY TRAINED TECHNICIAN.
- If an existing fixture is being replaced, remove it and note to which of the wires in the outlet box the fixture was attached. **DO NOT SEPARATE ANY OTHER WIRES THAT MAY BE IN THE BOX. DO NOT DAMAGE THE INSULATION OF OLDER WIRING.** In regular circumstances the **BLACK** wire will be the "Hot" lead and the **WHITE** wire will be the "Neutral" or "Common" lead. In older buildings it is always good practice to reconfirm the polarity of the wiring.

NOTICE

- The important safeguards and instructions outlined on this sheet cannot cover all possible conditions and situations that may occur. It must be understood that common sense, caution and care factors that cannot be built into any product. Caution and care must be supplied by the person(s) installing, operating and caring of this lighting fixture.
- This fixture is design to be mounted on a correctly installed standard round or octagon box or a through wiring box with a plaster frame. The box must be securely mounted to the structure of the building. The crossbar and hardware supplied should be used. Directly mounting the fixture to the outlet box may make it impossible to correctly align the fixture.

FIXTURE PREPARATION

1. Remove the fixture and parts bag(s) from the carton.

NOTICE:

Before discarding the carton, double check to make certain that all parts are found.

FIXTURE INSTALLATION

1. Insert the aircraft cable into the cable grip post of the canopy. Push the tab down on the cable grip and feed the aircraft cable. Repeat this step until you have insert all aircraft cable. (Refer Figure-1)
 2. Insert the SVT wire to bushing. (Refer Figure-1)
- NOTE:**
Insure the height of aircraft cable and SVT wire would be sufficient as you hang the fixture
3. To change the drop height based on your desired height, push the tab down on the grip post either pull or push the aircraft cable. Repeat this to all aircraft cable until the fixture is level and with the desired height. (Refer to Figure-4)
 4. Adjust the SVT wire base on the desired height. Pull/push the SVT wire to the bushing and leave 8" lead and ground wire above the canopy and cut the excess wire. (Refer to Figure-4)

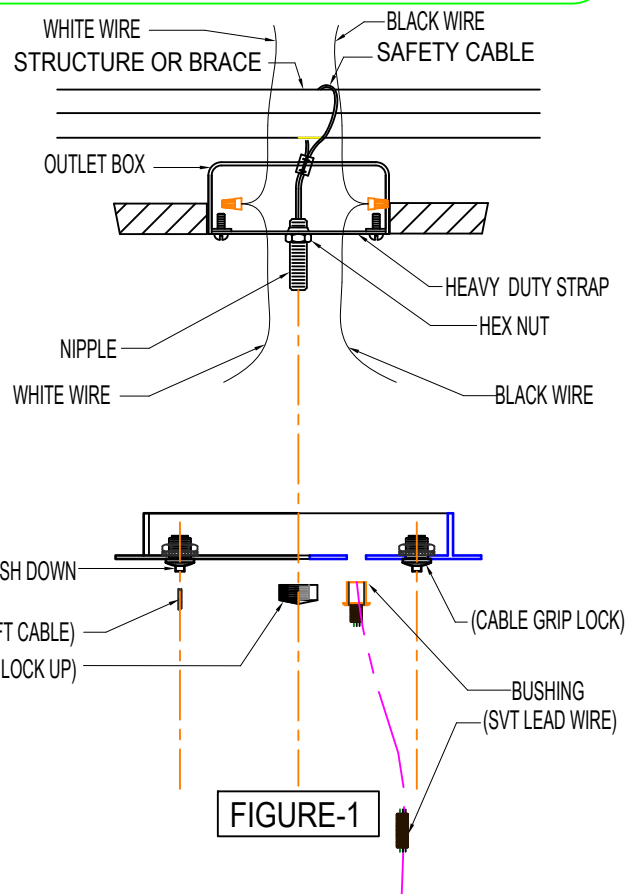

5. Attach the heavy duty strap to the outlet box using the mounting screws. Attach the safety cable to the building structure or brace. (Refer Figure-1).

NOTICE:
This luminaire must be mounted or supported independently of an outlet box.

WARNING
Refer to the illustration for correct and safe installation of safety cable. Failure to follow this instruction could result harm/damage to the fixture, property and/or person(s)!

6. Fasten the white wire of the led light to the white wire in the outlet box. Fasten the wires together with an approved fastener (wire nut). Starting about 1" below the fastener, tightly wrap the connection with electrical tape so that the connections seals the end of the fastener. (See Figure 2)

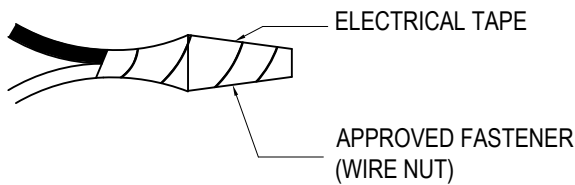

WARNING
Make sure that there is no exposed wire or strands that could cause a dangerous short circuit!

7. Connect the black wire of the led light to the black wire in the outlet box. Fasten the joined wire as in step 7.

NOTE:
LED light will be received assembled as in Replacement LED Instruction

NOTE:
Need another person that will hold the fixture during installation.

8. Thread the hex nut onto the nipple and the nipple into the heavy duty strap. Place the canopy over the nipple and against the ceiling. Adjust the nipple so that 1/2" of threads extend beyond the canopy. (Refer to Figure 1)

9. Using the center lock up, loosely fasten the fixture to the outlet box. Adjust the orientation of the fixture. Refer to step 3 and 4 and Figure 4.

10. Once the required orientation met, tighten the center lock. Refer to Figure 1 & 4.

11. Restore power to circuit at breaker or fuse box.

NOTICE:
Must use a incandescent dimmer with LED's on this fixture.
*Lutron Maestro dimmer not compatible.

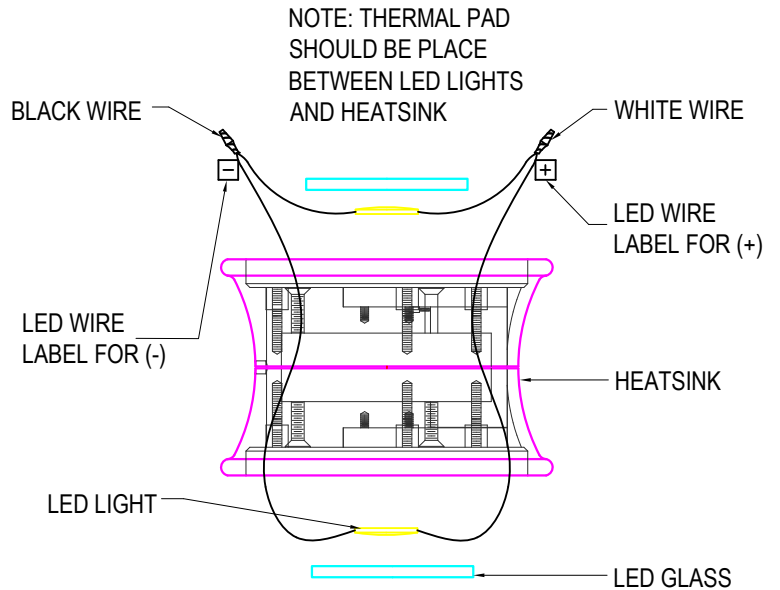

Replacement LED Instruction

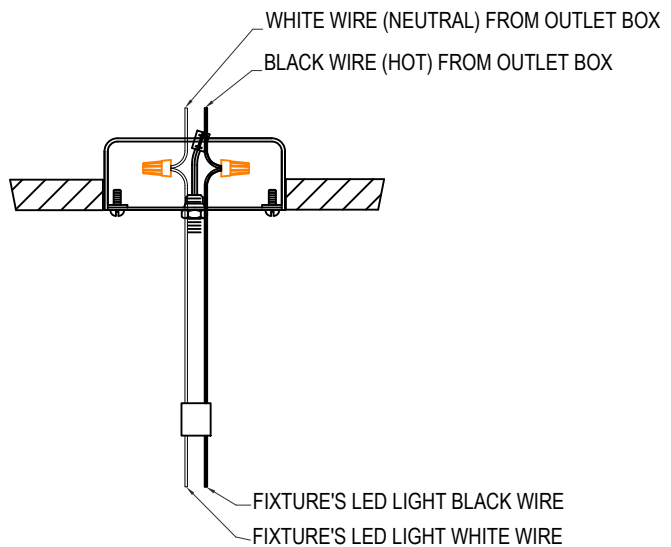

LED LIGHT TO OUTLET BOX
WIRE CONNECTION DETAILS

FIGURE-2

FIXTURE REASSEMBLY

NOTE:
Fixture should be reassemble prior to installation.

1. Identify Fixture A, Remove the protective cover on the LED Light on the bottom portion.
2. Identify Fixture B, place the glass on the top of fixture. Refer to Figure-3.
3. Attach Fixture B to Fixture A using the provided bolt. Use the appropriate tool in tightening the bolt. Refer to Figure 3.

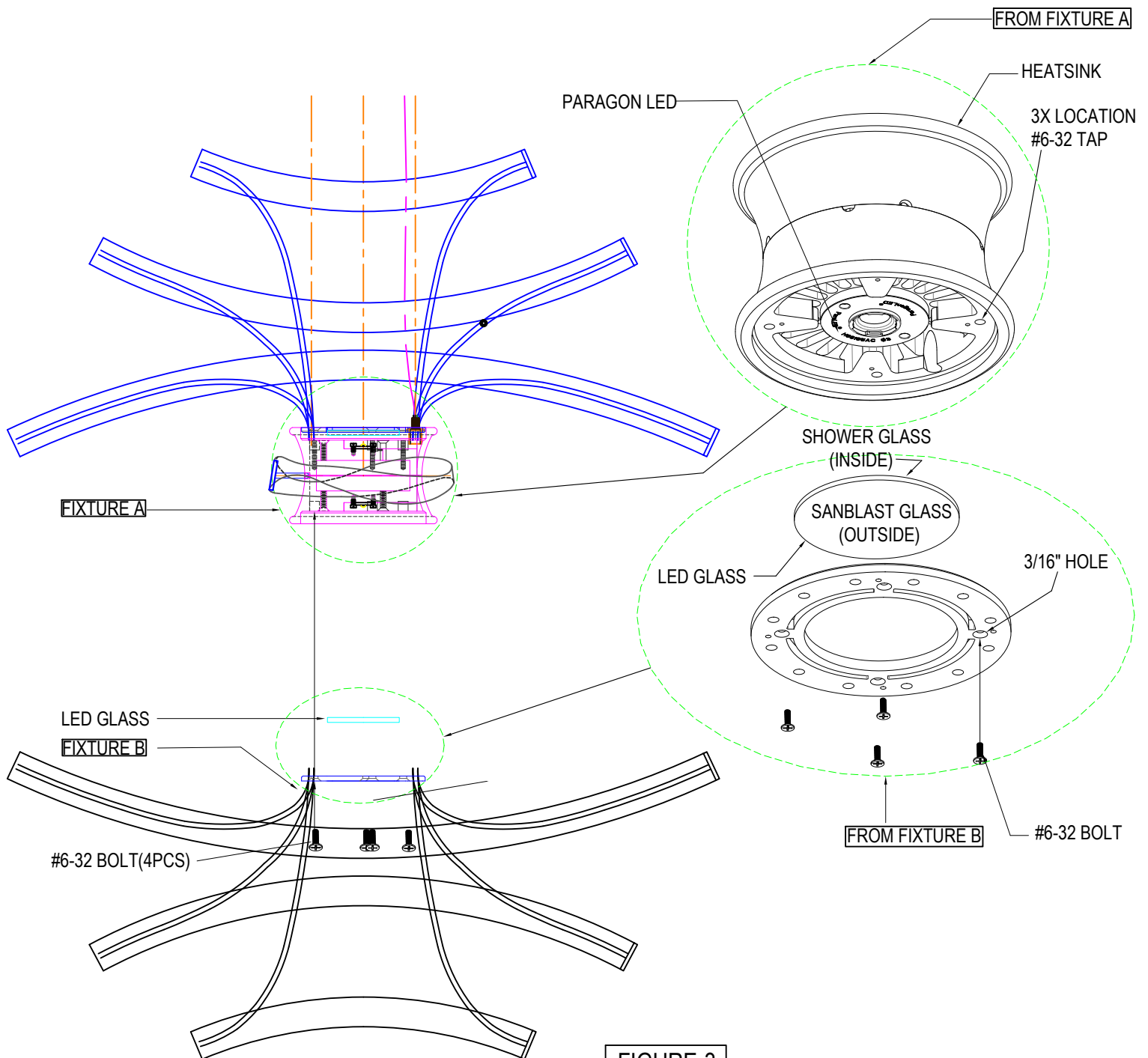

FIGURE-3

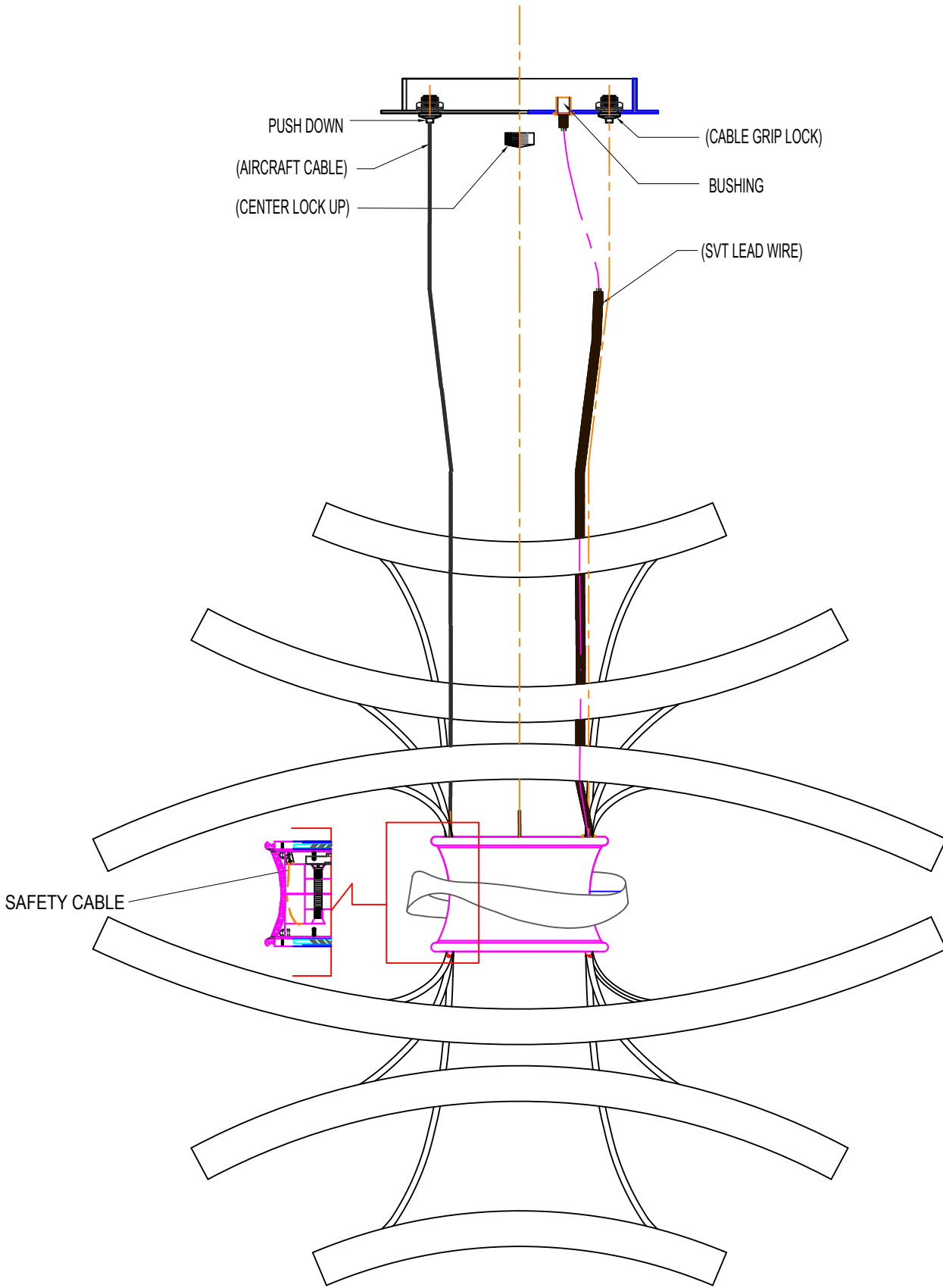

FIGURE- 4



WARNING

**DISCONNECT POWER BEFORE RELAMPING OR WIRING THE FIXTURE
READ ALL INSTRUCTIONS COMPLETELY BEFORE STARTING INSTALLATION.**



CAUTION

- TO AVOID THE RISK OF FIRE OR SHOCK, FIXTURE MUST BE INSTALLED IN COMPLIANCE WITH ALL APPLICABLE NATIONAL AND LOCAL ELECTRICAL/BUILDING CODES.
- INSTALLATION AND MAINTENANCE OF THIS UNIT REQUIRES AN ELECTRICIAN OR CERTIFIED FACTORY TRAINED TECHNICIAN.
- If an existing fixture is being replaced, remove it and note to which of the wires in the outlet box the fixture was attached. DO NOT SEPARATE ANY OTHER WIRES THAT MAY BE IN THE BOX. DO NOT DAMAGE THE INSULATION OF OLDER WIRING. In regular circumstances the BLACK wire will be the "Hot" lead and the WHITE wire will be the "Neutral" or "Common" lead. A GREEN or BARE COPPER wire is the "Ground". In older buildings it is always good practice to reconfirm the polarity of the wiring.

NOTICE

- The important safeguards and instructions outlined on this sheet cannot cover all possible conditions and situations that may occur. It must be understood that common sense, caution and care factors that cannot be built into any product. Caution and care must be supplied by the person(s) installing, operating and caring of this lighting fixture.
- This fixture is design to be mounted on a correctly installed standard round or octagon box or a through wiring box with a plaster frame. The box must be securely mounted to the structure of the building. The crossbar and hardware supplied should be used. Directly mounting the fixture to the outlet box may make it impossible to correctly align the fixture.

FIXTURE PREPARATION

1. Remove the fixture and parts bag(s) from the carton.

NOTICE:

Before discarding the carton, double check to make certain that all parts are found.

FIXTURE INSTALLATION

1. Insert the aircraft cable into the cable grip post of the canopy. Push the tab down on the cable grip and feed the aircraft cable. Repeat this step until you have insert all aircraft cable. (Refer Figure-1)

2. Insert the SVT wire to bushing. (Refer Figure-1)

NOTE:

Insure the height of aircraft cable and SVT wire would be sufficient as you hang the fixture

3. To change the drop height based on your desired height, push the tab down on the grip post either pull or push the aircraft cable. Repeat this to all aircraft cable until the fixture is level and with the desired height. (Refer to Figure-3)
4. Adjust the SVT wire base on the desired height. Pull/push the SVT wire to the bushing and leave 8" lead and ground wire above the canopy and cut the excess wire. (Refer to Figure-3)

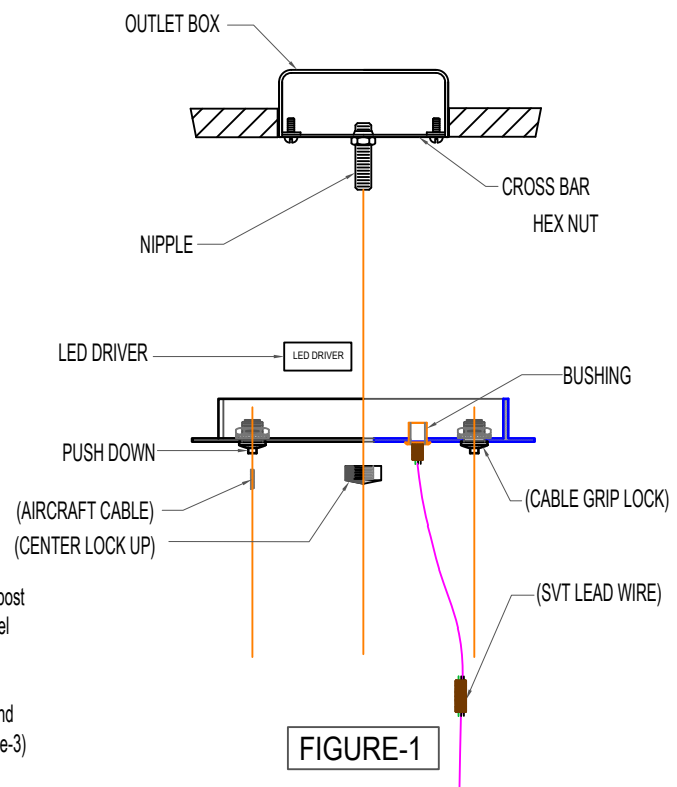
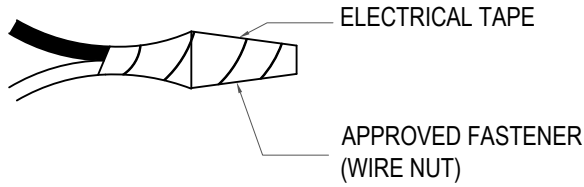

FIGURE-1

5. Place the led driver on the top of canopy and start wiring the fixture. Connect by fastening the black wire (-) coming from the fixture into the led driver where as blue wire (-) indicated. (Refer to the figure 2)

6. fasten the white wire (+) coming from the fixture into the led driver where as red wire (+)



WARNING
DO NOT EXCEED RECOMMENDED WATTAGE!

NOTICE:
Must use a incandescent dimmer with LED's on this fixture.
*Lutron Maestro dimmer not compatible.

WARNING
Never fasten the ground wire to the black or "hot" wire! Failure to follow this instruction could result in serious injury or death!

WARNING
Make sure that there is no exposed wire or strands that could cause a dangerous short circuit!

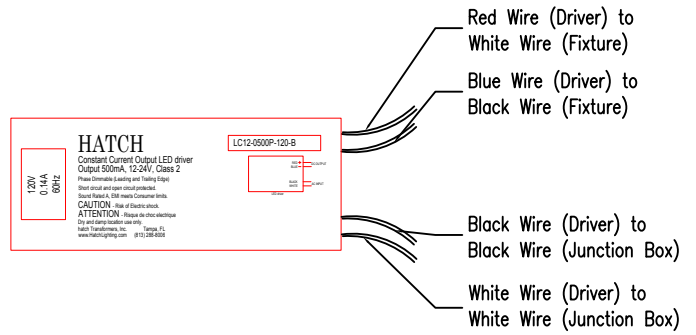

SEE ALSO DRIVER COLOR CODING
LED LAMP TO LED DRIVER
WIRE CONNECTION DETAILS

FIGURE-2

7. Attach the cross bar to the outlet box using the mounting screws. (Refer Figure-1).

8. Fasten the ground wire to the green or bare copper wire in the outlet box (if outlet box is plastic) or to the green screw on the cross bar.

9. Fasten the white wire from the junction box into the led driver where as white wire indicated (AC Input) (Refer Figure-2)

10. Fasten the black wire from the junction box into the led driver where as black wire indicated (AC Input). (Refer Figure-2)

NOTE:
Need another person that will hold the fixture during installation.

11. Thread the hex nut onto the nipple and the nipple into the cross bar . Place the canopy over the nipple and against the ceiling. Adjust the nipple so that 1/2" of threads extend beyond the canopy. (Refer to Figure 1)

12. Using the center lock up, loosely fasten the fixture to the outlet box. Adjust the orientation of the fixture. Refer to step 3 and 4 and Figure 3.

13. Once the required orientation met, tighten the center lock. Refer to Figure 1 & 3.

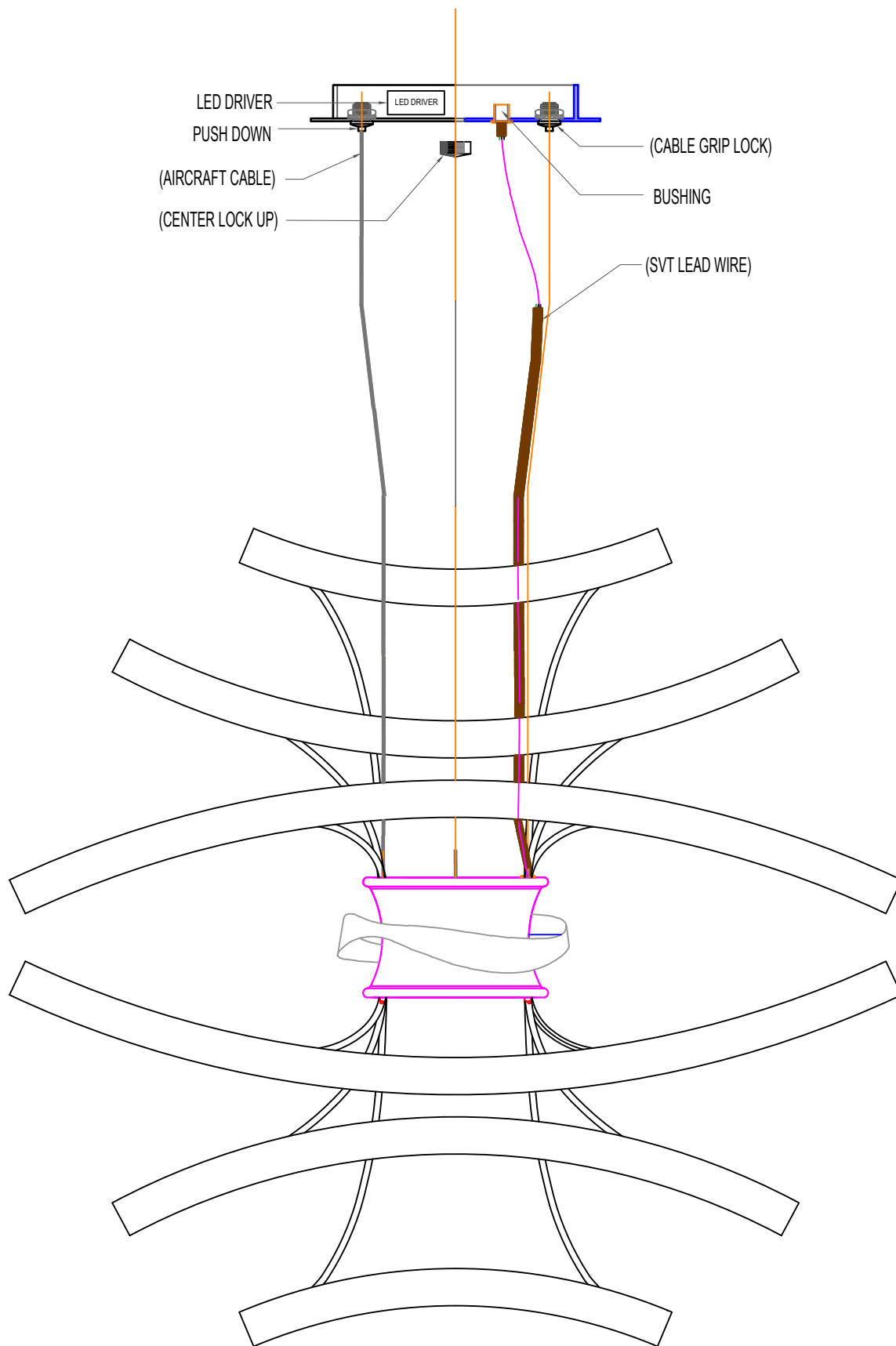

FIGURE-3

FIXTURE REASSEMBLY

NOTE:

Fixture should be reassemble prior to installation.

1. Identify Fixture A, Remove the protective cover on the LED Light on the bottom portion.
2. Identify Fixture B, place the glass on the top of fixture. Refer to Figure-3.
3. Attach Fixture B to Fixture A using the provided bolt. Use the appropriate tool in tightening the bolt. Refer to Figure 3.

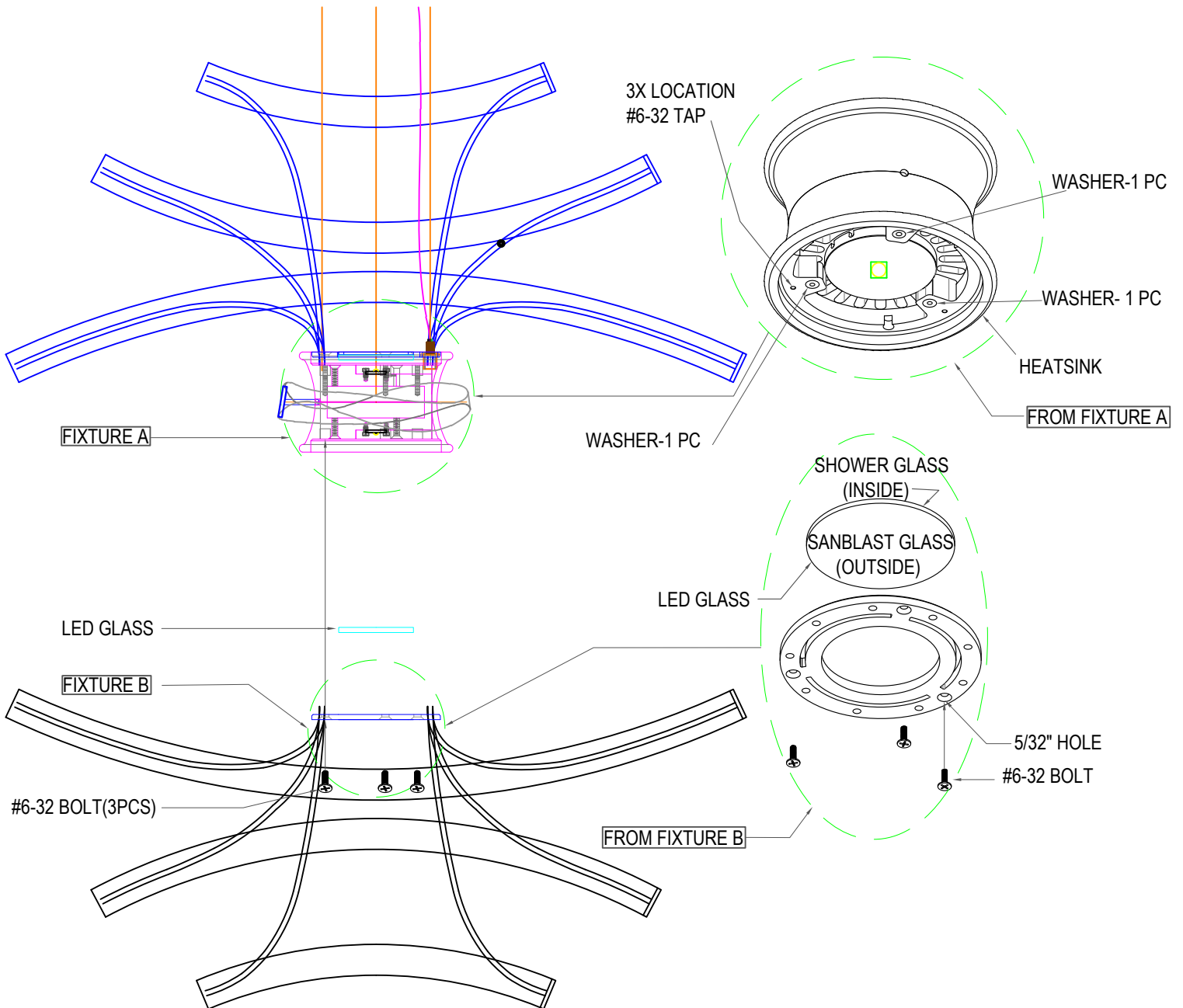

FIGURE- 4

14. Restore power to circuit at breaker or fuse box.

WARNING

**DISCONNECT POWER BEFORE RELAMPING OR WIRING THE FIXTURE
READ ALL INSTRUCTIONS COMPLETELY BEFORE STARTING INSTALLATION.**

CAUTION

- **TO AVOID THE RISK OF FIRE OR SHOCK, FIXTURE MUST BE INSTALLED IN COMPLIANCE WITH ALL APPLICABLE NATIONAL AND LOCAL ELECTRICAL/BUILDING CODES.**
- **INSTALLATION AND MAINTENANCE OF THIS UNIT REQUIRES AN ELECTRICIAN OR CERTIFIED FACTORY TRAINED TECHNICIAN.**
- **If an existing fixture is being replaced, remove it and note to which of the wires in the outlet box the fixture was attached. DO NOT SEPARATE ANY OTHER WIRES THAT MAY BE IN THE BOX. DO NOT DAMAGE THE INSULATION OF OLDER WIRING. In regular circumstances the BLACK wire will be the "Hot" lead and the WHITE wire will be the "Neutral" or "Common" lead. In older buildings it is always good practice to reconfirm the polarity of the wiring.**

NOTICE

- **The important safeguards and instructions outlined on this sheet cannot cover all possible conditions and situations that may occur. It must be understood that common sense, caution and care factors that cannot be built into any product. Caution and care must be supplied by the person(s) installing, operating and caring of this lighting fixture.**
- **This fixture is design to be mounted on a correctly installed standard round or octagon box or a through wiring box with a plaster frame. The box must be securely mounted to the structure of the building. The crossbar and hardware supplied should be used. Directly mounting the fixture to the outlet box may make it impossible to correctly align the fixture.**

FIXTURE PREPARATION

1. Remove the fixture and parts bag(s) from the carton.

NOTICE:

Before discarding the carton, double check to make certain that all parts are found.

FIXTURE INSTALLATION

1. Insert the aircraft cable into the cable grip post of the canopy. Push the tab down on the cable grip and feed the aircraft cable. Repeat this step until you have insert all aircraft cable. (Refer Figure-1)
2. Insert the SVT wire to bushing. (Refer Figure-1)

NOTE:

Insure the height of aircraft cable and SVT wire would be sufficient as you hang the fixture

3. To change the drop height based on your desired height, push the tab down on the grip post either pull or push the aircraft cable. Repeat this to all aircraft cable until the fixture is level and with the desired height. (Refer to Figure-4)
4. Adjust the SVT wire base on the desired height. Pull/push the SVT wire to the bushing and leave 8" lead wire above the canopy and cut the excess wire. (Refer to Figure-4)

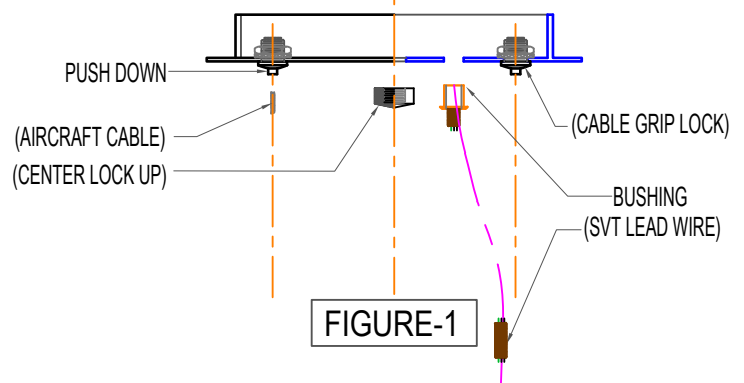
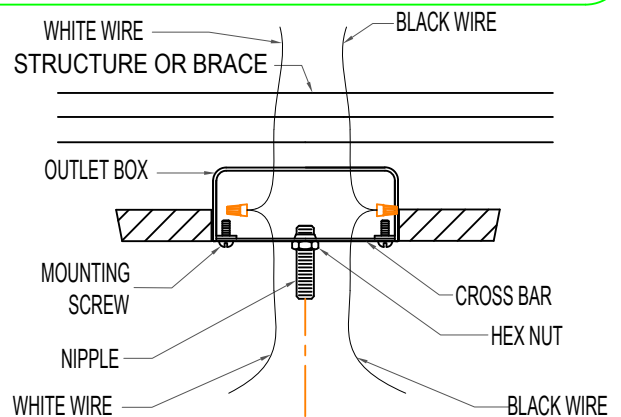

5. Attach the crossbar to the outlet box using the mounting screws. (Refer Figure-1).

NOTICE:
This luminaire must be mounted or supported independently of an outlet box.

NOTICE:
Must use an incandescent dimmer with LED's on this fixture.
*Lutron Maestro dimmer not compatible.

6. Fasten the white wire of the led light to the white wire in the outlet box. Fasten the wires together with an approved fastener (wire nut). Starting about 1" below the fastener, tightly wrap the connection with electrical tape so that the connections seals the end of the fastener. (See Figure 2)

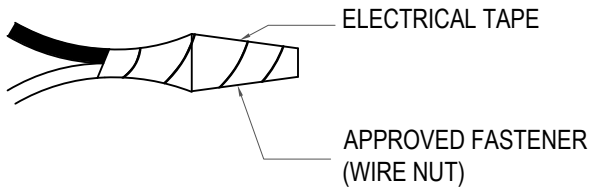

WARNING
Make sure that there is no exposed wire or strands that could cause a dangerous short circuit!

7. Connect the black wire of the led light to the black wire in the outlet box. Fasten the joined wire as in step 6.

NOTE:
LED light will be received assembled as in Replacement LED Instruction

NOTE:
Need another person that will hold the fixture during installation.

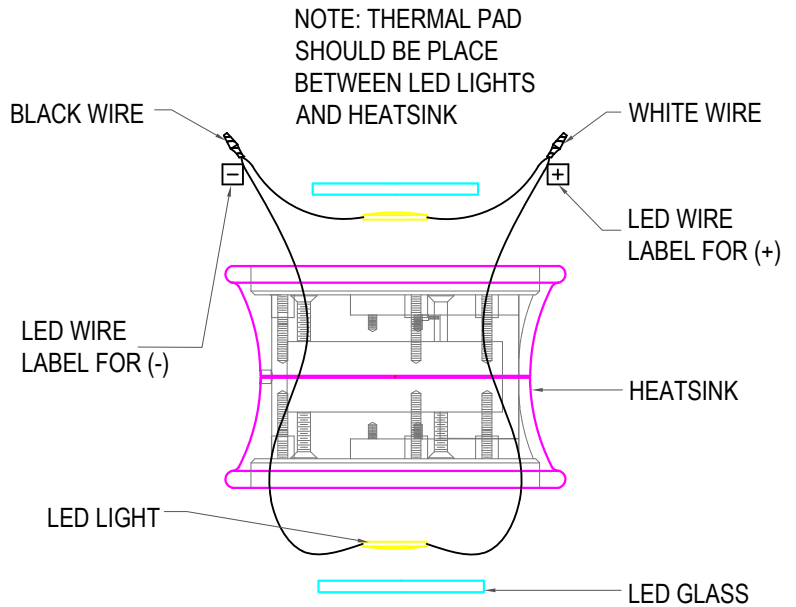

Replacement LED Instruction

8. Thread the hex nut onto the nipple and the nipple into the crossbar. Place the canopy over the nipple and against the ceiling. Adjust the nipple so that 1/2" of threads extend beyond the canopy. (Refer to Figure 1)

9. Using the center lock up, loosely fasten the fixture to the outlet box. Adjust the orientation of the fixture. Refer to step 3 and 4 and Figure 4.

10. Once the required orientation met, tighten the center lock. Refer to Figure 1 & 4.

11. Restore power to circuit at breaker or fuse box.

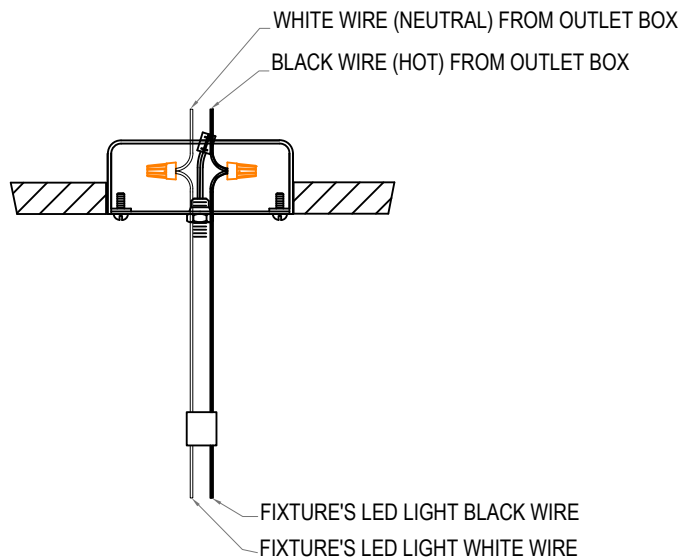

LED LIGHT TO OUTLET BOX
WIRE CONNECTION DETAILS

FIGURE-2

FIXTURE REASSEMBLY

NOTE:
 Fixture should be reassemble prior to installation.

1. Identify Fixture A, Remove the protective cover on the LED Light on the bottom portion.
2. Identify Fixture B, place the glass on the top of fixture. Refer to Figure-3.
3. Attach Fixture B to Fixture A using the provided bolt. Use the appropriate tool in tightening the bolt. Refer to Figure-3

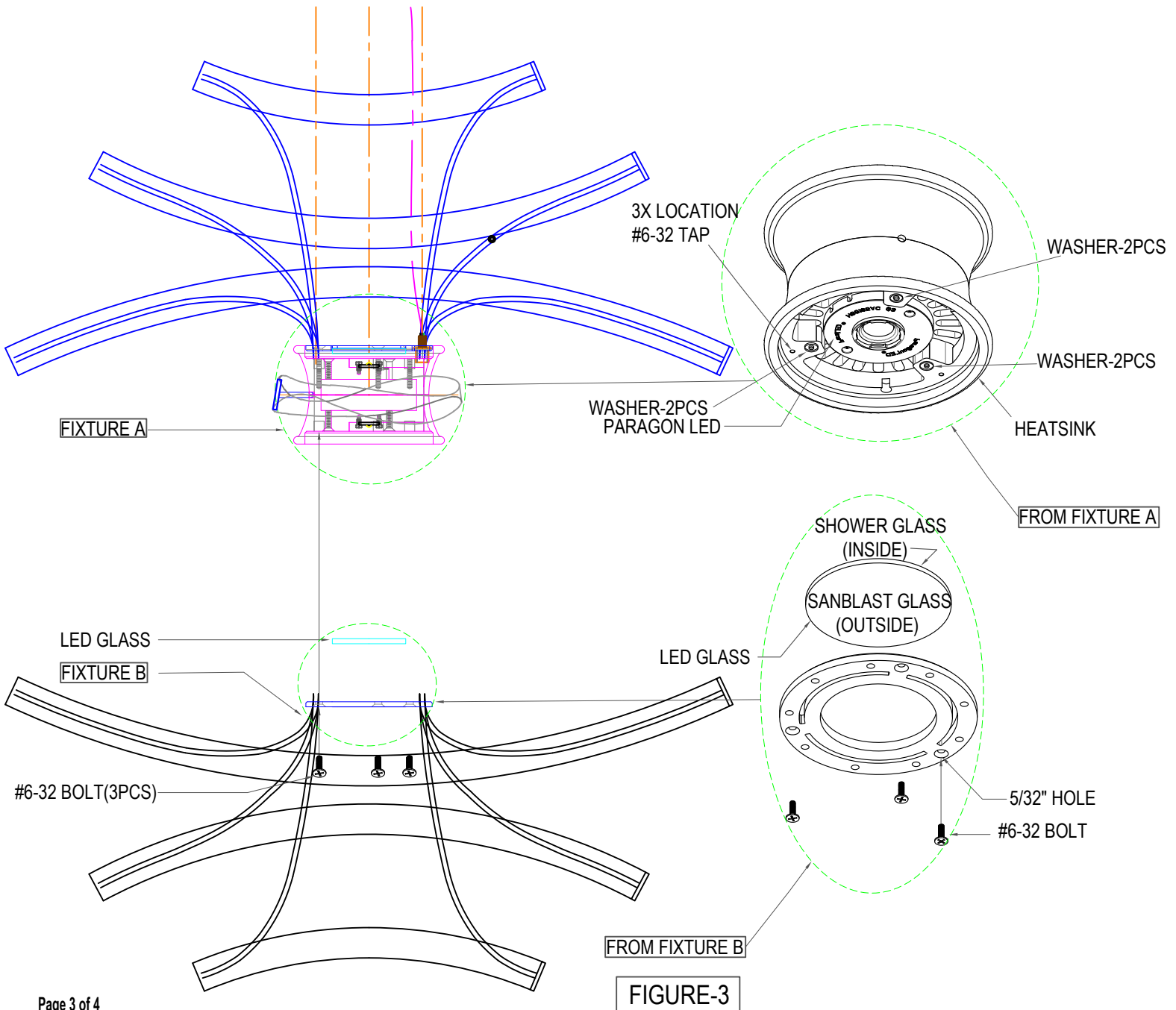

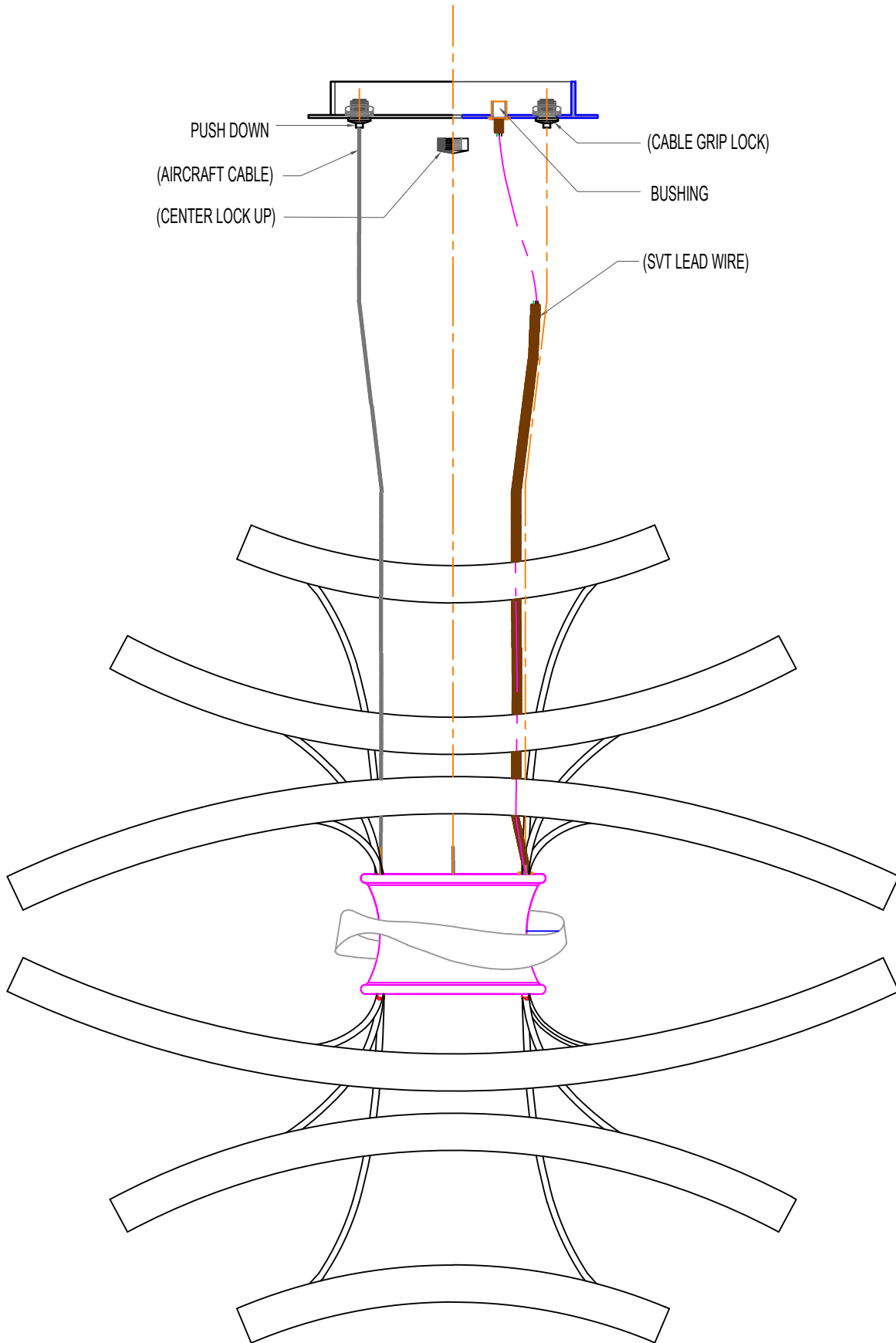

FIGURE- 4

WARNING

DISCONNECT POWER BEFORE RELAMPING OR WIRING THE FIXTURE
READ ALL INSTRUCTIONS COMPLETELY BEFORE STARTING INSTALLATION.

CAUTION

- TO AVOID THE RISK OF FIRE OR SHOCK, FIXTURE MUST BE INSTALLED IN COMPLIANCE WITH ALL APPLICABLE NATIONAL AND LOCAL ELECTRICAL/BUILDING CODES.
- INSTALLATION AND MAINTENANCE OF THIS UNIT REQUIRES AN ELECTRICIAN OR CERTIFIED FACTORY TRAINED TECHNICIAN.
- If an existing fixture is being replaced, remove it and note to which of the wires in the outlet box the fixture was attached. DO NOT SEPARATE ANY OTHER WIRES THAT MAY BE IN THE BOX. DO NOT DAMAGE THE INSULATION OF OLDER WIRING. In regular circumstances the BLACK wire will be the "Hot" lead and the WHITE wire will be the "Neutral" or "Common" lead. In older buildings it is always good practice to reconfirm the polarity of the wiring.

NOTICE

- The important safeguards and instructions outlined on this sheet cannot cover all possible conditions and situations that may occur. It must be understood that common sense, caution and care factors that cannot be built into any product. Caution and care must be supplied by the person(s) installing, operating and caring of this lighting fixture.
- This fixture is design to be mounted on a correctly installed standard round or octagon box or a through wiring box with a plaster frame. The box must be securely mounted to the structure of the building. The crossbar and hardware supplied should be used. Directly mounting the fixture to the outlet box may make it impossible to correctly align the fixture.

FIXTURE PREPARATION

1. Remove the fixture and parts bag(s) from the carton.

NOTICE:

Before discarding the carton, double check to make certain that all parts are found.

FIXTURE INSTALLATION

1. Insert the aircraft cable into the cable grip post of the canopy. Push the tab down on the cable grip and feed the aircraft cable. Repeat this step until you have insert all aircraft cable. (Refer Figure-1)
 2. Insert the SVT wire to bushing. (Refer Figure-1)
- NOTE:**
Insure the height of aircraft cable and SVT wire would be sufficient as you hang the fixture
3. To change the drop height based on your desired height, push the tab down on the grip post either pull or push the aircraft cable. Repeat this to all aircraft cable until the fixture is level and with the desired height. (Refer to Figure-4)
 4. Adjust the SVT wire base on the desired height. Pull/push the SVT wire to the bushing and leave 8" lead above the canopy and cut the excess wire. (Refer to Figure-4)

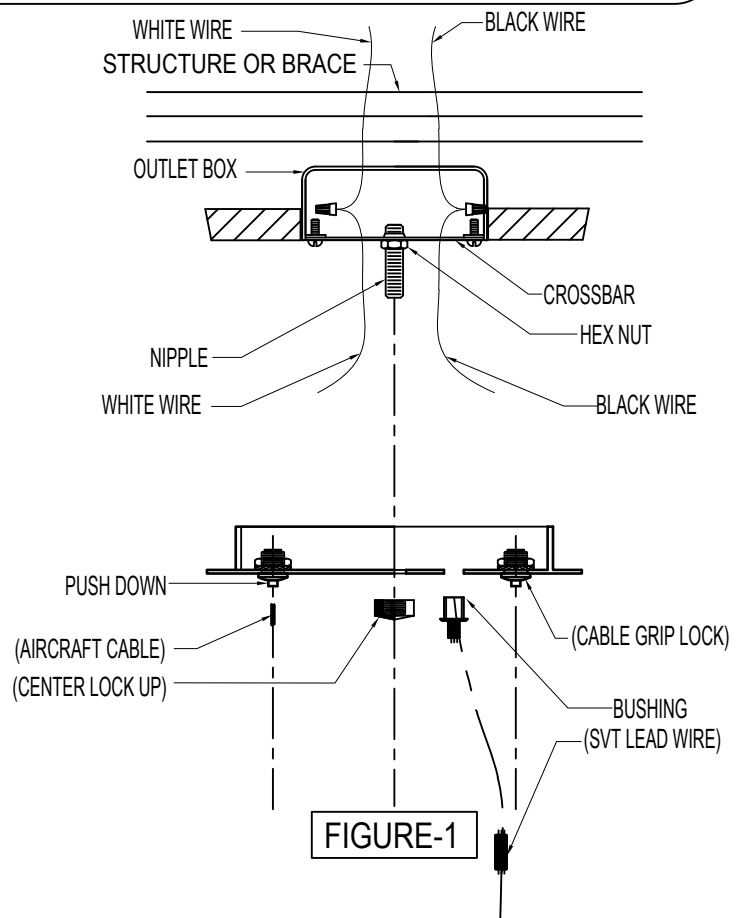

5. Attach the crossbar to the outlet box using the mounting screws. Attach the safety cable to the building structure or brace. (Refer Figure-1).

NOTICE:
This luminaire must be mounted or supported independently of an outlet box.

WARNING
Refer to the illustration for correct and safe installation of safety cable. Failure to follow this instruction could result harm/damage to the fixture, property and/or person(s)!

6. Fasten the white wire of the led light to the white wire in the outlet box. Fasten the wires together with an approved fastener (wire nut). Starting about 1" below the fastener, tightly wrap the connection with electrical tape so that the connections seals the end of the fastener. (See Figure 2)

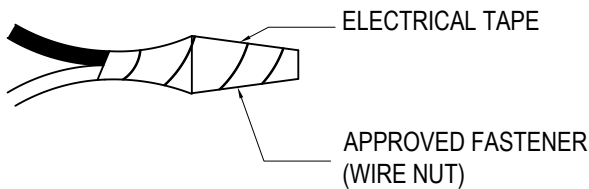

WARNING
Make sure that there is no exposed wire or strands that could cause a dangerous short circuit!

7. Connect the black wire of the led light to the black wire in the outlet box. Fasten the joined wire as in step 7.

NOTE:
LED light will be received assembled as in Replacement LED Instruction

NOTE:
Need another person that will hold the fixture during installation.

8. Thread the hex nut onto the nipple and the nipple into the crossbar. Place the canopy over the nipple and against the ceiling. Adjust the nipple so that 1/2" of threads extend beyond the canopy. (Refer to Figure 1)

9. Using the center lock up, loosely fasten the fixture to the outlet box. Adjust the orientation of the fixture. Refer to step 3 and 4 and Figure 4.

10. Once the required orientation met, tighten the center lock. Refer to Figure 1 & 4.

11. Restore power to circuit at breaker or fuse box.

NOTICE:
Must use a incandescent dimmer with LED's on this fixture.
*Lutron Maestro dimmer not compatible.

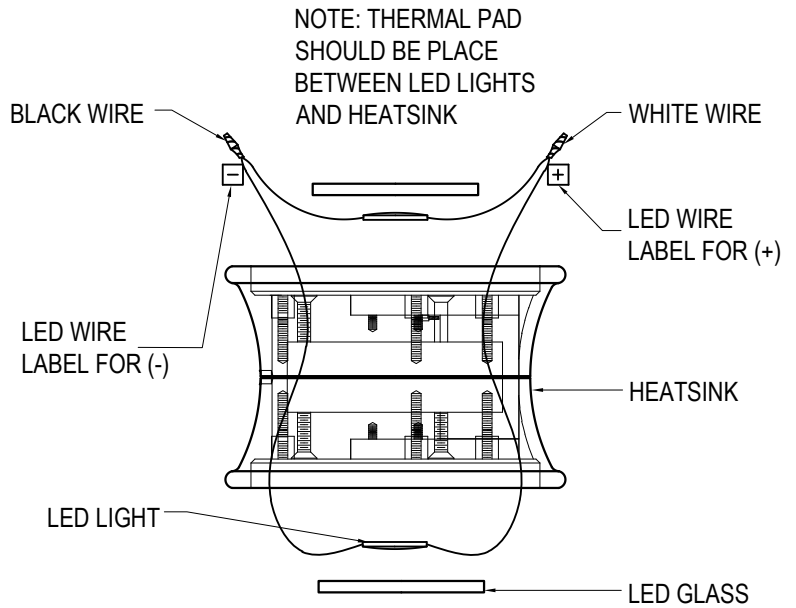

Replacement LED Instruction

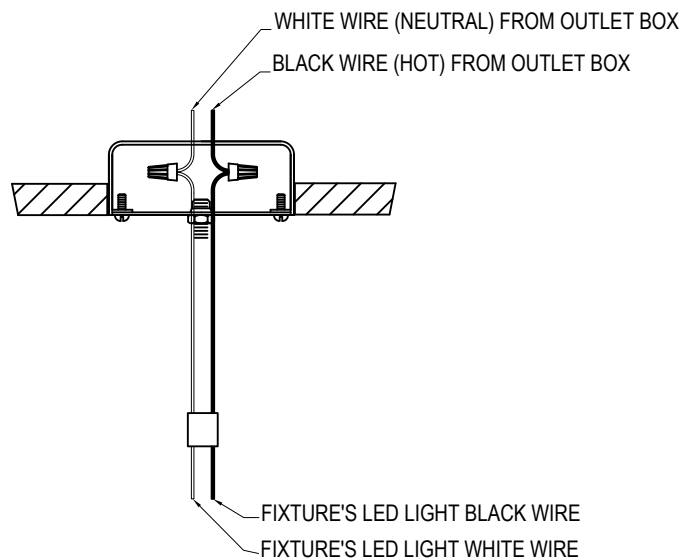

LED LIGHT TO OUTLET BOX
WIRE CONNECTION DETAILS

FIGURE-2

FIXTURE REASSEMBLY

NOTE:

Fixture should be reassemble prior to installation.

1. Identify Fixture A, Remove the protective cover on the LED Light on the bottom portion.
2. Identify Fixture B, put set of washer and place the glass on the top of fixture. Refer to Figure-3.
3. Attach Fixture B to Fixture A using the provided bolt. Use the appropriate tool in tightening the bolt. Refer to Figure 3.

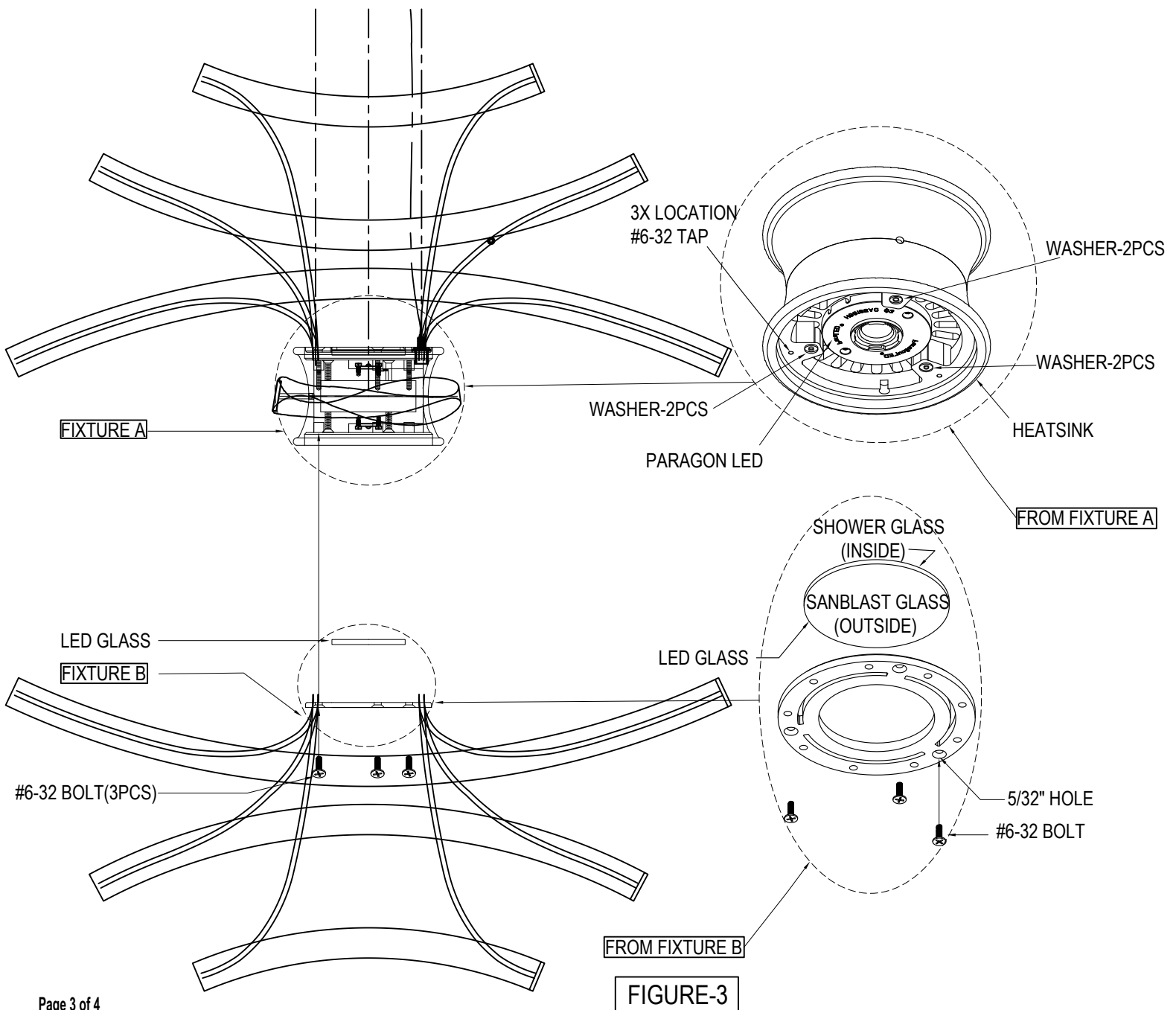

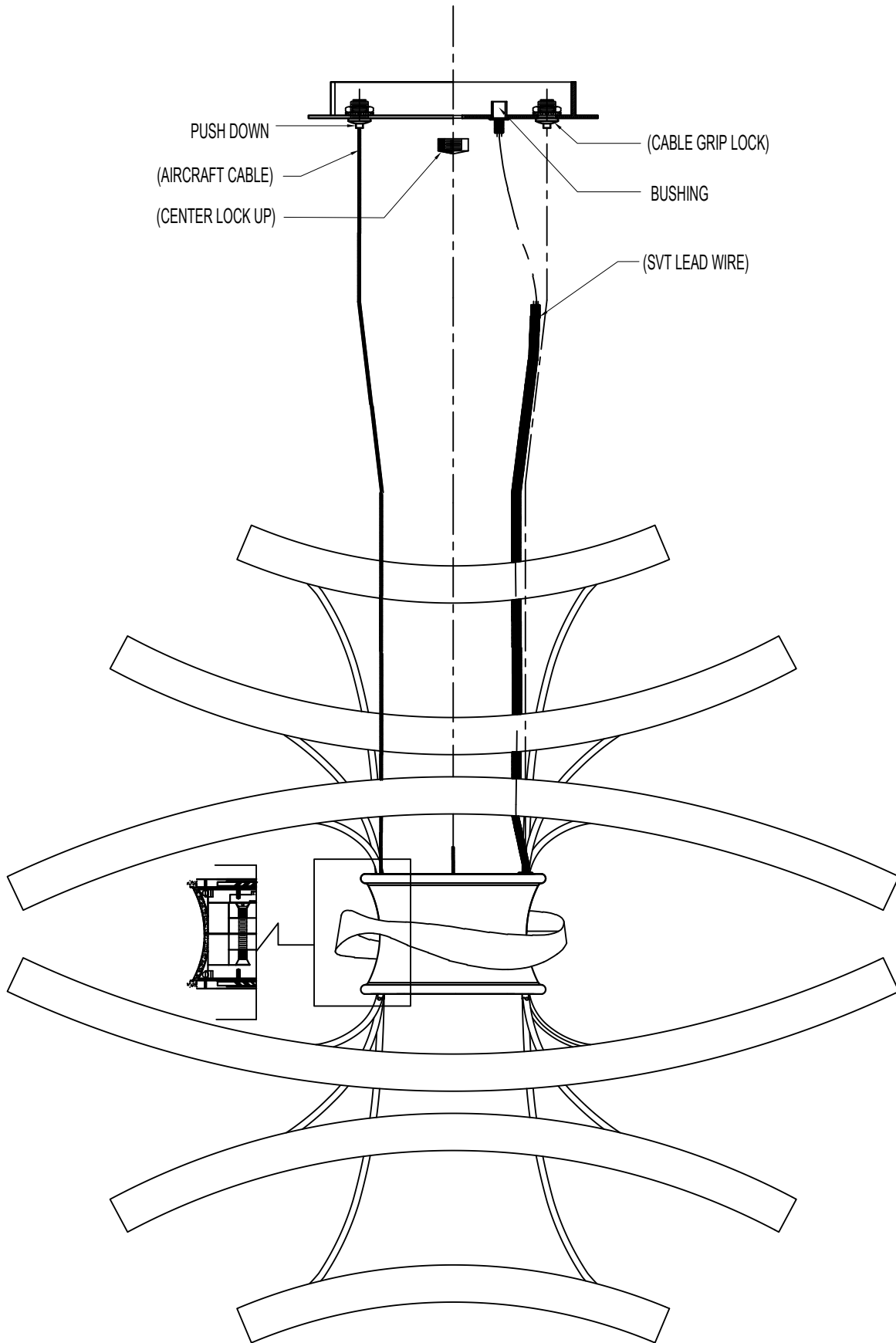

FIGURE- 4

⚠ WARNING

**DISCONNECT POWER BEFORE RELAMPING OR WIRING THE FIXTURE
READ ALL INSTRUCTIONS COMPLETELY BEFORE STARTING INSTALLATION.**

⚠ CAUTION

- **TO AVOID THE RISK OF FIRE OR SHOCK, FIXTURE MUST BE INSTALLED IN COMPLIANCE WITH ALL APPLICABLE NATIONAL AND LOCAL ELECTRICAL/BUILDING CODES.**
- **INSTALLATION AND MAINTENANCE OF THIS UNIT REQUIRES AN ELECTRICIAN OR CERTIFIED FACTORY TRAINED TECHNICIAN.**
- **If an existing fixture is being replaced, remove it and note to which of the wires in the outlet box the fixture was attached. DO NOT SEPARATE ANY OTHER WIRES THAT MAY BE IN THE BOX. DO NOT DAMAGE THE INSULATION OF OLDER WIRING. In regular circumstances the BLACK wire will be the "Hot" lead and the WHITE wire will be the "Neutral" or "Common" lead. In older buildings it is always good practice to reconfirm the polarity of the wiring.**

NOTICE

- **The important safeguards and instructions outlined on this sheet cannot cover all possible conditions and situations that may occur. It must be understood that common sense, caution and care factors that cannot be built into any product. Caution and care must be supplied by the person(s) installing, operating and caring of this lighting fixture.**
- **This fixture is design to be mounted on a correctly installed standard round or octagon box or a through wiring box with a plaster frame. The box must be securely mounted to the structure of the building. The crossbar and hardware supplied should be used. Directly mounting the fixture to the outlet box may make it impossible to correctly align the fixture.**

FIXTURE PREPARATION

1. Remove the fixture and parts bag(s) from the carton.

NOTICE:

Before discarding the carton, double check to make certain that all parts are found.

FIXTURE INSTALLATION

1. Insert the aircraft cable into the cable grip post of the canopy. Push the tab down on the cable grip and feed the aircraft cable. Repeat this step until you have insert all aircraft cable. (Refer Figure-1)
2. Insert the SVT wire to bushing. (Refer Figure-1)

NOTE:

Insure the height of aircraft cable and SVT wire would be sufficient as you hang the fixture

3. To change the drop height based on your desired height, push the tab down on the grip post either pull or push the aircraft cable. Repeat this to all aircraft cable until the fixture is level and with the desired height. (Refer to Figure-4)
4. Adjust the SVT wire base on the desired height. Pull/push the SVT wire to the bushing and leave 8" lead wire above the canopy and cut the excess wire. (Refer to Figure-4)

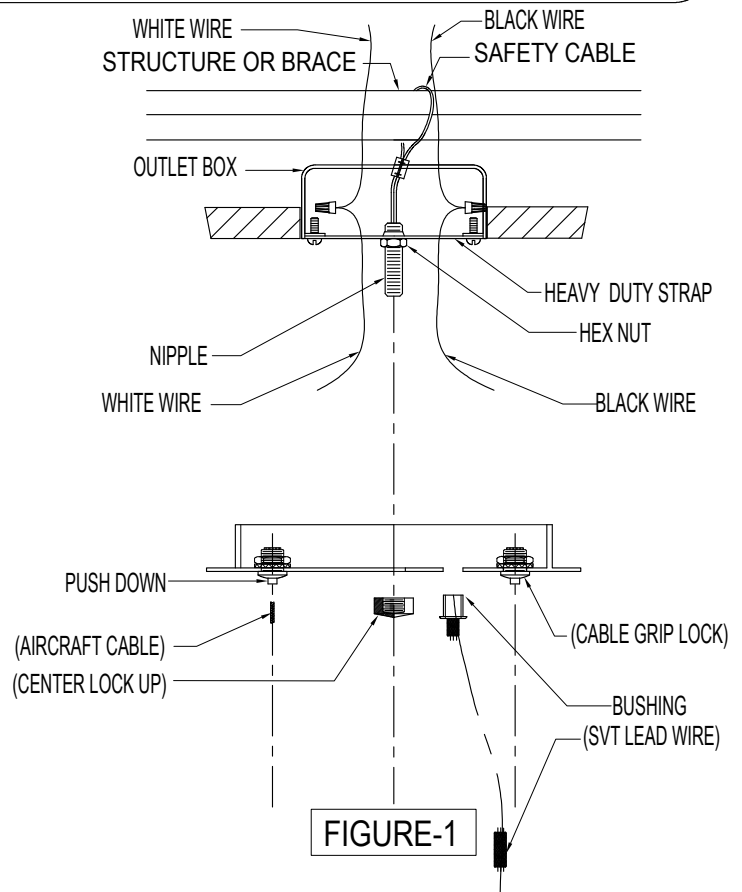

5. Attach the heavy duty strap to the outlet box using the mounting screws. Attach the safety cable to the building structure or brace. (Refer Figure-1).

NOTICE:
This luminaire must be mounted or supported independently of an outlet box.

WARNING
Refer to the illustration for correct and safe installation of safety cable. Failure to follow this instruction could result harm/damage to the fixture, property and/or person(s)!

6. Fasten the white wire of the led light to the white wire in the outlet box. Fasten the wires together with an approved fastener (wire nut). Starting about 1" below the fastener, tightly wrap the connection with electrical tape so that the connections seals the end of the fastener. (See Figure 2)

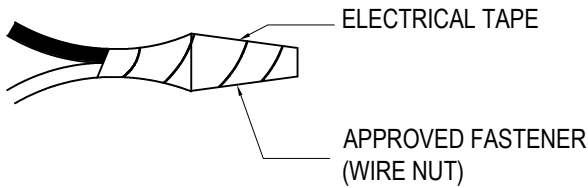

WARNING
Make sure that there is no exposed wire or strands that could cause a dangerous short circuit!

7. Connect the black wire of the led light to the black wire in the outlet box. Fasten the joined wire as in step 7.

NOTE:
LED light will be received assembled as in Replacement LED Instruction

NOTE:
Need another person that will hold the fixture during installation.

8. Thread the hex nut onto the nipple and the nipple into the heavy duty strap. Place the canopy over the nipple and against the ceiling. Adjust the nipple so that 1/2" of threads extend beyond the canopy. (Refer to Figure 1)

9. Using the center lock up, loosely fasten the fixture to the outlet box. Adjust the orientation of the fixture. Refer to step 3 and 4 and Figure 4.

10. Once the required orientation met, tighten the center lock. Refer to Figure 1 & 4.

11. Restore power to circuit at breaker or fuse box.

NOTICE:
Must use a incandescent dimmer with LED's on this fixture.
*Lutron Maestro dimmer not compatible.

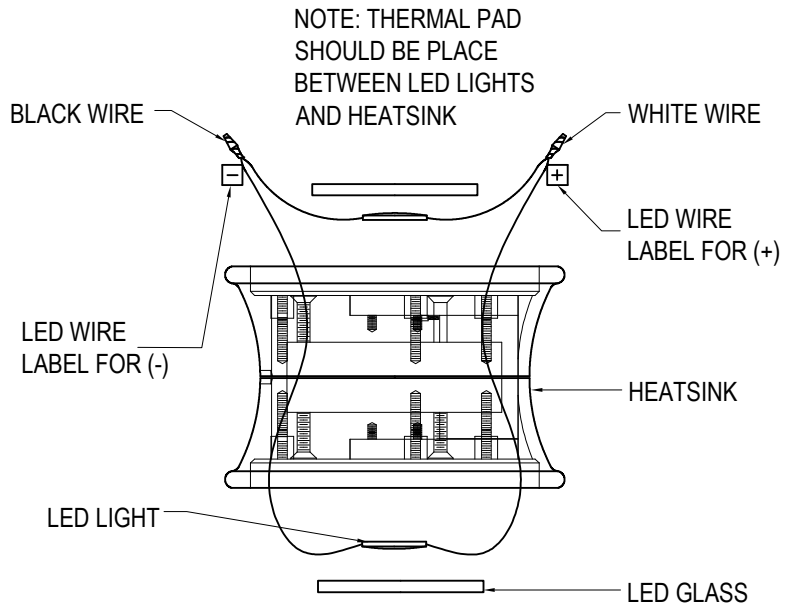

Replacement LED Instruction

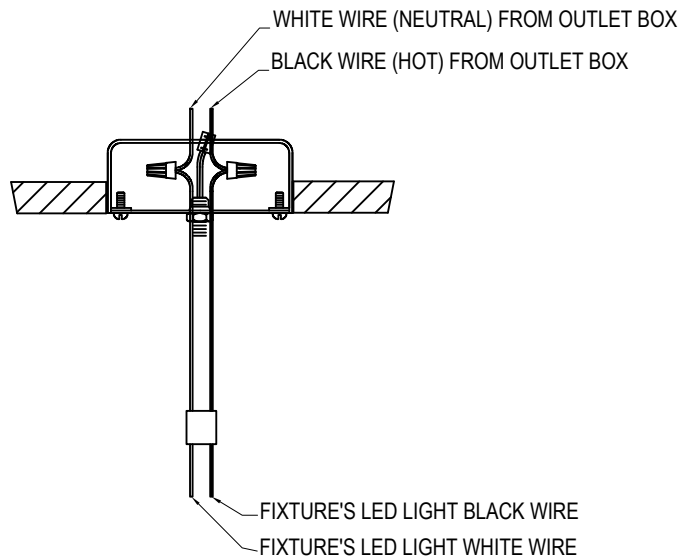

LED LIGHT TO OUTLET BOX
WIRE CONNECTION DETAILS

FIGURE-2

FIXTURE REASSEMBLY

NOTE:
Fixture should be reassemble prior to installation.

1. Identify Fixture A, Remove the protective cover on the LED Light on the bottom portion.
2. Identify Fixture B, place the glass on the top of fixture. Refer to Figure-3.
3. On top of Fixture B look for a dot sticker/markings. Align this to Fixture A wherein same marking will be seen on the bottom of the fixture. Refer to Figure-3.
4. Attach the two using the provided bolt. Use the appropriate tool in tightening the bolt. Refer to Figure 3.

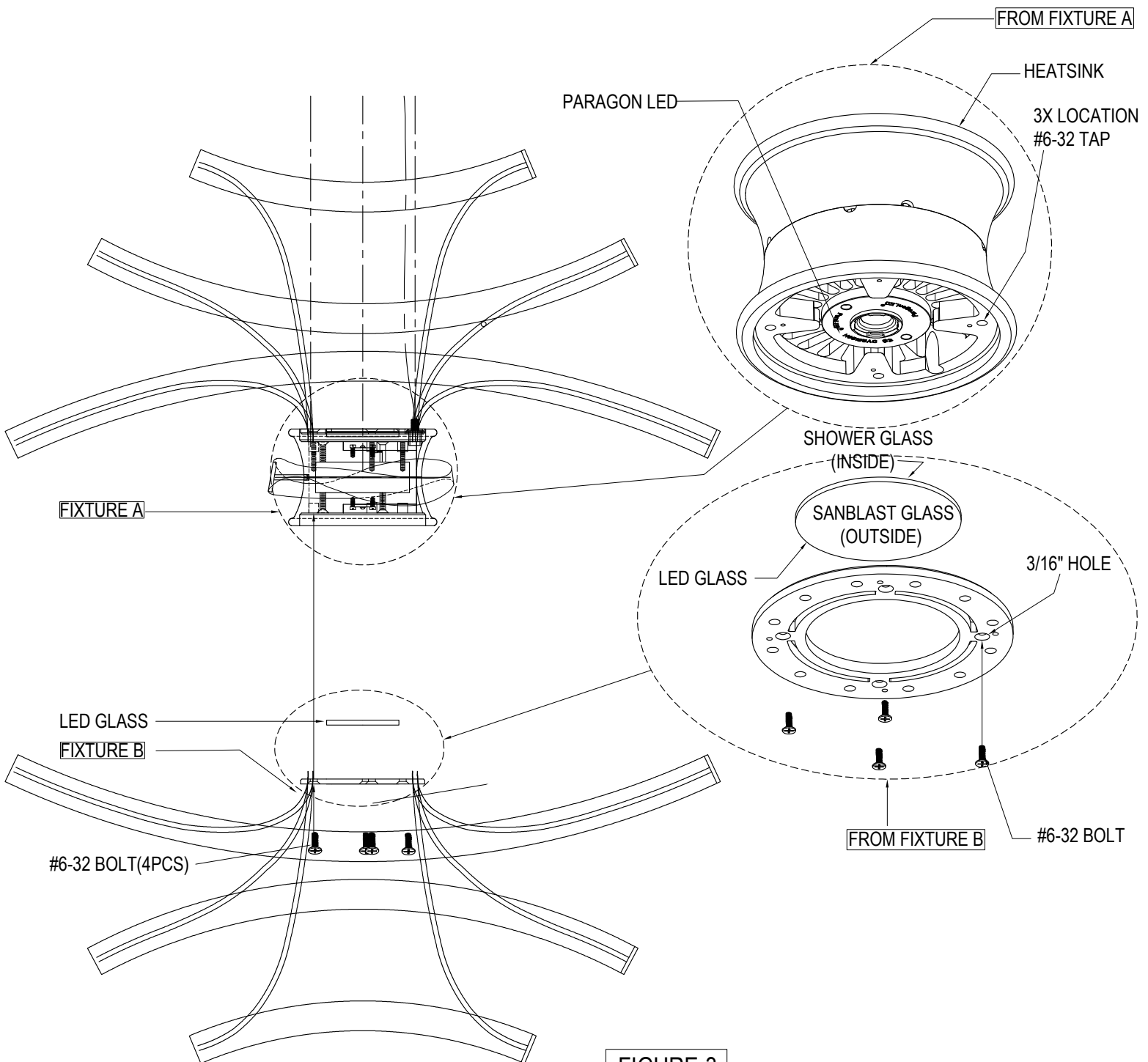

FIGURE-3

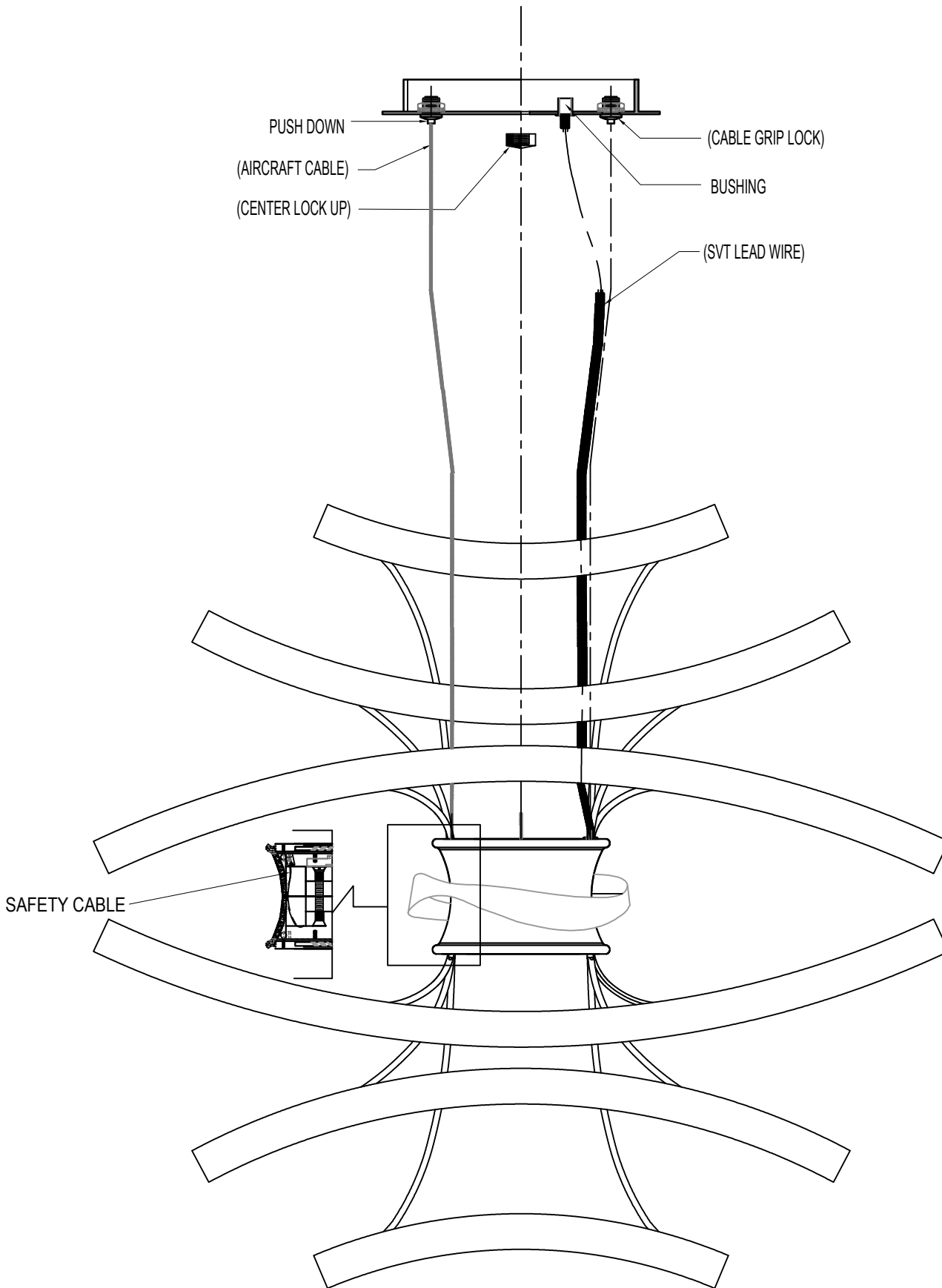

FIGURE- 4