



**ASSEMBLY INSTRUCTIONS & PRODUCT INFO: ALFRESCO BENCH 22**

Loll Designs inspires people to appreciate the outdoors.

**PRODUCT CARE**

Your new Loll furniture is a no maintenance product. You'll never need to paint or stain it and it can be left outside all year regardless of the season. It will not rot, even if left standing in water. Nonetheless, we're pretty sure your Loll furniture will get a lot of use and will at some point need cleaning. We recommend a garden hose and incorporating a soft bristle brush. Adding a tablespoon or two of your favorite eco-friendly soap to the wash will get everything squeaky clean. Mineral deposits left over from hard water can be removed with a solution of vinegar and water. Loll offers a cleaning kit that has everything you need for great results. Also see our cleaning video at [loll designs.com/videos](http://loll designs.com/videos).

**5 YR WARRANTY**

Loll Designs strives to build long-term relationships based on confidence and trust with our customers. We sit beside, on top, and beneath the quality of our fine furniture and will make things right if you are not completely satisfied with your purchase. Loll Designs hereby guarantees that the piece will be of good quality and workmanship, free from faults and defects. Loll warrants that all components will not fail, under normal use, for five years from the year mark on the piece or the date of purchase. \*For commercial orders the warranty is three years.

**SHARE YOUR LOLL**



[loll designs.com](http://loll designs.com)  
877.740.3387



**DAMAGED PRODUCT**

Sometimes accidents occur. Please inspect your Loll furniture when you receive it to make sure that it has not been damaged during shipping. If damage has occurred please take digital pictures of the damaged furniture and the box it was shipped in, and email them to [sales@loll designs.com](mailto:sales@loll designs.com) or call Customer Service using our toll free number: 877.740.3387, ext. 1. The damage will be assessed and you will be contacted with a solution to the problem. It may be helpful to save all of your packaging material in case a return is necessary.

**ASSEMBLY TIPS**

*\*Please read before beginning assembly!*

To avoid damaging furniture perform the assembly of your Loll furniture on a clean soft surface like a blanket, carpet, or the flattened cardboard box the furniture was shipped in. Components should not be unnecessarily forced together! If it seems parts aren't fitting together you likely have something wrong and you should reread the instructions to ensure you are aligning the proper components. If your piece of furniture requires "Blocks" for assembly one side may have protective film on it. This surface is hidden after assembly so the film can remain on the block or it can be removed. Use a Cordless Screw Gun if you have one and know how to use it. Set the clutch setting at medium torque. We do not recommend using an electric drill with a cord and without a clutch to install bolts in inserts as you can easily overtighten and damage the product. All bolts come standard with a thread coating to reduce bolts loosening after assembly while still allowing removal and reuse of the bolt. Start all bolts by hand, with the Allen Key, or the Loll Tool and tighten firmly until parts are drawn tight together and you can't muscle the bolt any tighter. It's virtually impossible to over tighten by hand. Watch the assembly videos at [www.loll designs.com/videos](http://www.loll designs.com/videos) for even more information and visual aids. If you have more questions please contact your Loll Sales Associate or Customer Service for support at 877.740.3387. A **Pro Tool Kit** can also be purchased from Loll for multi piece assembly jobs.

*\*\* Please Recycle the BOX and paper packaging. The green plastic stretch wrap we use is compostable.*



Scan for assembly tips and videos

**BLOCK & BOLT INSTALLATION**

Insert bolts through countersunk hole side of blocks as shown below.

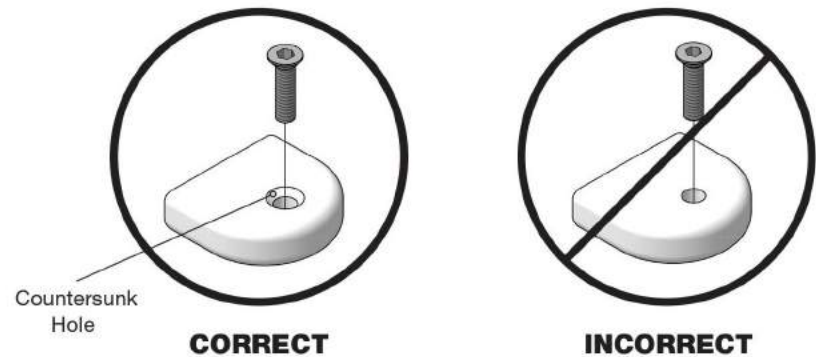

**LOLL TOOL**

Locate the box marked "Tool Included" before beginning assembly.



**We want you to love your Loll.**

Reach out if you need lollygagging assistance.  
877-740-3387  
[sales@loll designs.com](mailto:sales@loll designs.com)  
5912 Waseca Street | Duluth, Minnesota 55807







# ALFRESCO BENCH 22

## ASSEMBLY INSTRUCTIONS

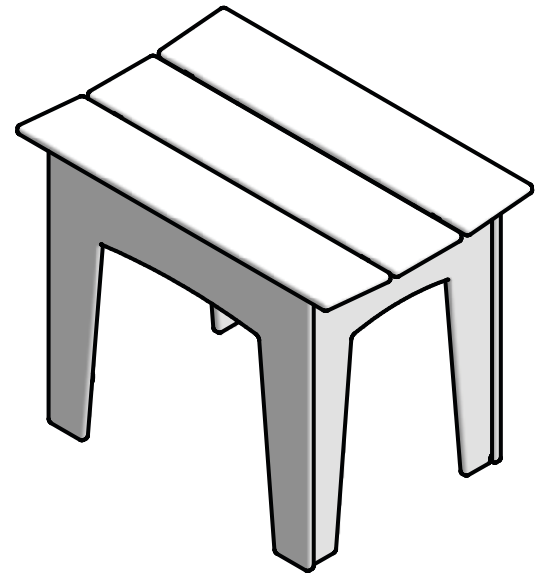
lolldesigns.com 1-877-740-3387

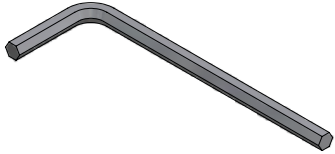

### INCLUDED HARDWARE

	COUNT		COUNT
7/8" BOLT (ORANGE)	16	5/32" ALLEN WRENCH	1
			

### INCLUDED PARTS

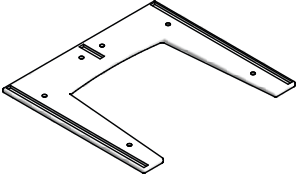
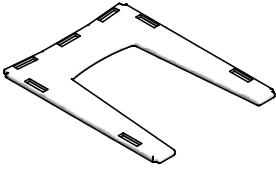
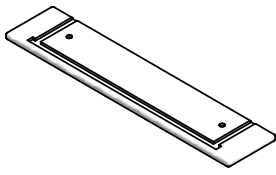
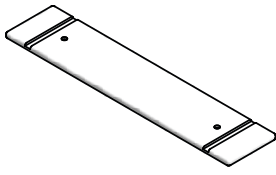
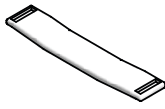
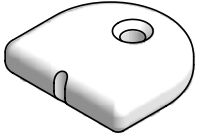
SIDE	COUNT	END	COUNT	SIDE SLAT	COUNT	MIDDLE SLAT	COUNT	BRACE	COUNT	BLOCK G	COUNT
	2		2		2		1		1		16

### ASSEMBLY INSTRUCTIONS

\* It is very important that you finger tighten all bolts into inserts to ensure that you do not cross-thread bolts and inserts before tightening. It will also be easier if you wait to tighten bolts until you have all bolts installed and the piece completely assembled. This will allow for more movement of individual pieces and help in aligning holes with inserts. Use the Allen Tool provided to finish tighten bolt until snug.

#### 1 ATTACH ENDS AND SIDES

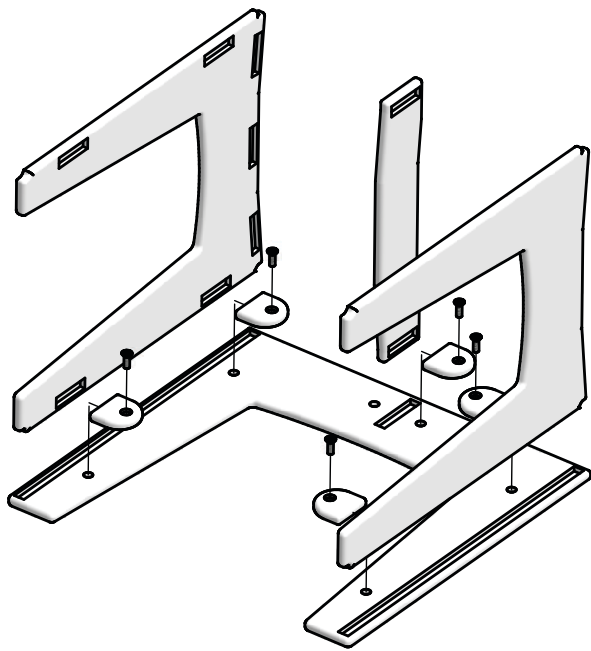

\*Please read **Assembly Tips** before beginning assembly. Fit Ends into groove track cut outs of Side. Place Blocks G into End pocket cut outs. Insert Bolts through the Blocks G into the Side and finger tighten. Fit Brace into the middle cut out of the Side and attach using Block G. Repeat this step to attach the opposite Side.

#### 2 ATTACH MIDDLE SEAT SLAT

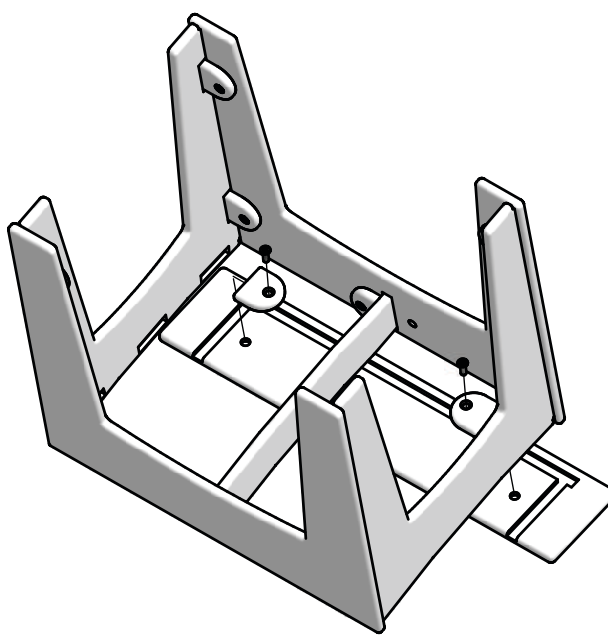

Fit the Side Slat groove track cut outs over the Side and Ends. Place Blocks G into the notch cut outs of the Ends and insert Bolts through the Blocks G into the Side Slat and finger tighten.

#### 3 ATTACH SEAT SLATS

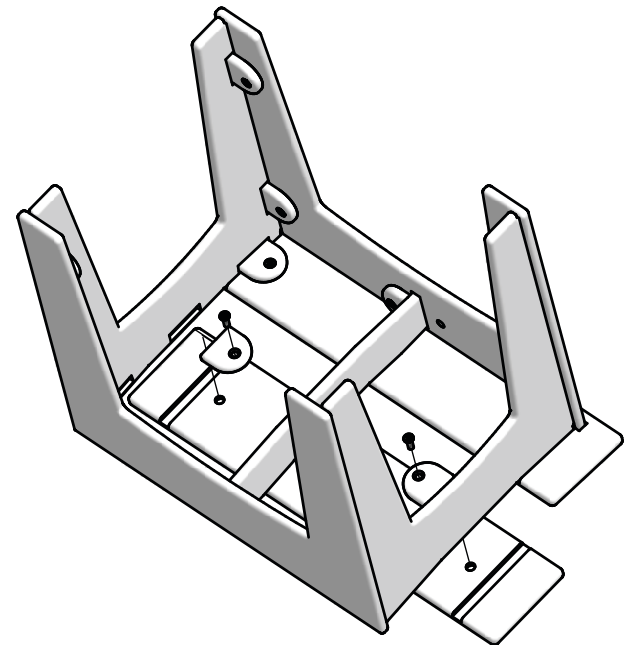

Fit the Middle Slat groove track cut outs over the Ends. Place Blocks G into the notch cut outs of the Ends and insert Bolts through the Blocks G into the Middle Slat and finger tighten. Repeat Step 2 to attach second Side Slat.

\*Using provided wrench securely tighten all bolts.

**DAMAGED PRODUCT**

Sometimes accidents occur. Please inspect your Loll furniture when you receive it to make sure that it has not been damaged during shipping. If damage has occurred please take digital pictures of the damaged furniture and the box it was shipped in, and email them to sales@loll designs.com or call Customer Service using our toll free number: 877.740.3387, ext. 1. The damage will be assessed and you will be contacted with a solution to the problem. It may be helpful to save all of your packaging material in case a return is necessary.



**ASSEMBLY TIPS**

*\*Please read before beginning assembly!*

To avoid damaging furniture perform the assembly of your Loll furniture on a clean soft surface like a blanket, carpet, or the flattened cardboard box the furniture was shipped in. Components should not be unnecessarily forced together! If it seems parts aren't fitting together you likely have something wrong and you should reread the instructions to ensure you are aligning the proper components. If your piece of furniture requires "Blocks" for assembly one side may have protective film on it. This surface is hidden after assembly so the film can remain on the block or it can be removed. Use a Cordless Screw Gun if you have one and know how to use it. Set the clutch setting at medium torque. We do not recommend using an electric drill with a cord and without a clutch to install bolts in inserts as you can easily overtighten and damage the product. All bolts come standard with a thread coating to reduce bolts loosening after assembly while still allowing removal and reuse of the bolt. Start all bolts by hand, with the Allen Key, or the Loll Tool and tighten firmly until parts are drawn tight together and you can't muscle the bolt any tighter. It's virtually impossible to over tighten by hand. Watch the assembly videos at [www.lolldesigns.com/videos](http://www.lolldesigns.com/videos) for even more information and visual aids. If you have more questions please contact your Loll Sales Associate or Customer Service for support at 877.740.3387. A **Pro Tool Kit** can also be purchased from Loll for multi piece assembly jobs.

**\*\* Please Recycle the BOX and paper packaging. The green plastic stretch wrap we use is compostable.**



Scan for assembly tips and videos



**BLOCK & BOLT INSTALLATION**

Insert bolts through countersunk hole side of blocks as shown below.

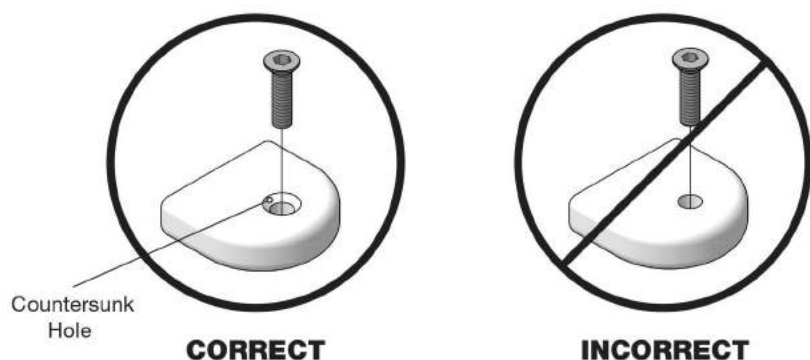

**LOLL TOOL**

Locate the box marked "Tool Included" before beginning assembly.



**We want you to love your Loll.**

Reach out if you need lollygagging assistance.  
877-740-3387  
sales@lolldesigns.com  
5912 Waseca Street | Duluth, Minnesota 55807



**ASSEMBLY INSTRUCTIONS & PRODUCT INFO:**

**ALFRESCO BENCH 47 & 58**

Loll Designs inspires people to appreciate the outdoors.

**PRODUCT CARE**

Your new Loll furniture is a no maintenance product. You'll never need to paint or stain it and it can be left outside all year regardless of the season. It will not rot, even if left standing in water. Nonetheless, we're pretty sure your Loll furniture will get a lot of use and will at some point need cleaning. We recommend a garden hose and incorporating a soft bristle brush. Adding a tablespoon or two of your favorite eco-friendly soap to the wash will get everything squeaky clean. Mineral deposits left over from hard water can be removed with a solution of vinegar and water. Loll offers a cleaning kit that has everything you need for great results. Also see our cleaning video at [lolldesigns.com/videos](http://lolldesigns.com/videos).

**5 YR WARRANTY**

Loll Designs strives to build long-term relationships based on confidence and trust with our customers. We sit beside, on top, and beneath the quality of our fine furniture and will make things right if you are not completely satisfied with your purchase. Loll Designs hereby guarantees that the piece will be of good quality and workmanship, free from faults and defects. Loll warrants that all components will not fail, under normal use, for five years from the year mark on the piece or the date of purchase. \*For commercial orders the warranty is three years.



**SHARE YOUR LOLL**



[lolldesigns.com](http://lolldesigns.com)  
877.740.3387

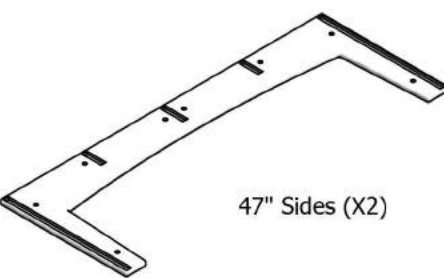
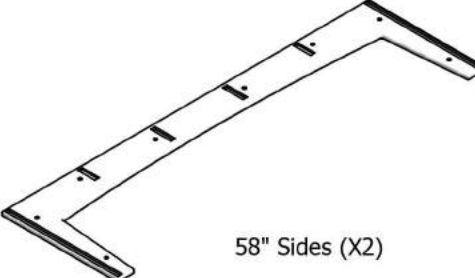
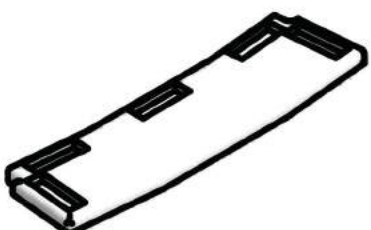
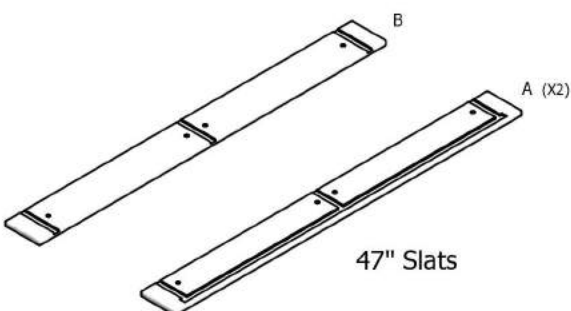
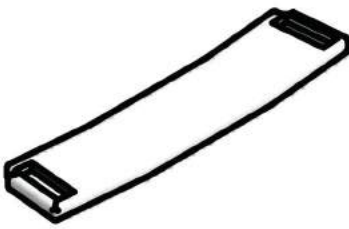
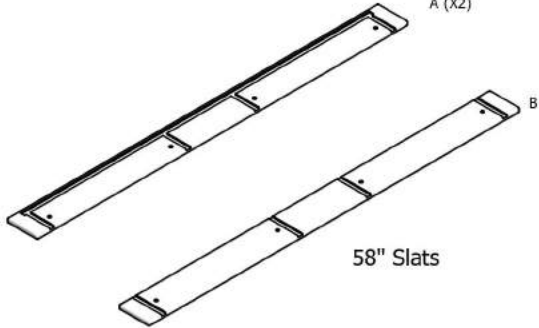
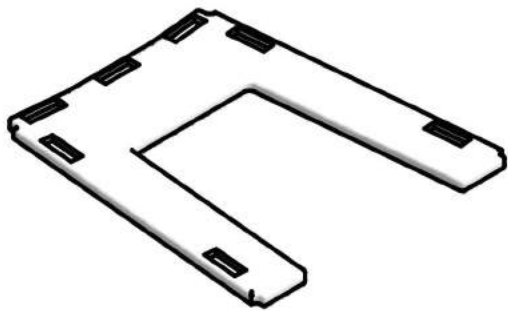

**INCLUDED PARTS**

SIDES		COUNT	LARGE RIB		
		<b>2</b>	<b>1</b>	<b>2</b>	
			47"	58"	
 <p>47" Sides (X2)</p>			 <p>58" Sides (X2)</p>		
					
SEAT SLATS		COUNT	SMALL RIB		
		<b>3</b>	<b>2</b>		
 <p>47" Slats</p>					
			 <p>58" Slats</p>		
END	COUNT	BLOCK G		1" BOLT	
	<b>2</b>	<b>23</b>	<b>28</b>	<b>23</b>	<b>28</b>
		47"	58"	47"	58"
					

# ASSEMBLY INSTRUCTIONS

\* It is very important that you finger tighten all bolts into inserts to ensure that you do not cross-thread bolts and inserts before tightening. It will also be easier if you wait to tighten bolts until you have all bolts installed and the piece completely assembled. This will allow for more movement of individual pieces and help in aligning holes with inserts. Use the Allen Tool provided to finish tighten bolt until snug.

## 1 ATTACH ENDS

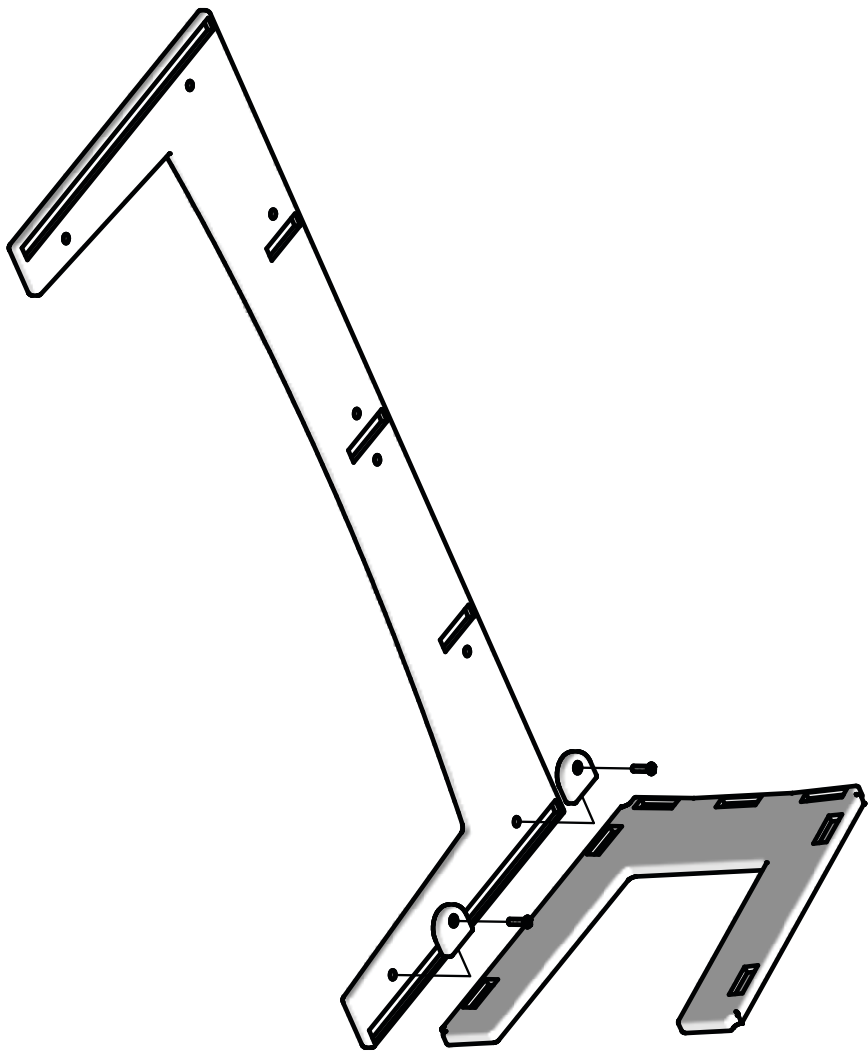

**\*Please read Assembly Tips before beginning assembly.**  
Fit End into the Side's groove track cut out. Place Blocks G into the Ends pocket cut outs, insert bolts through the blocks into the Side's threaded holes, and finger tighten. Repeat for opposite End.

## 2 ATTACH RIBS

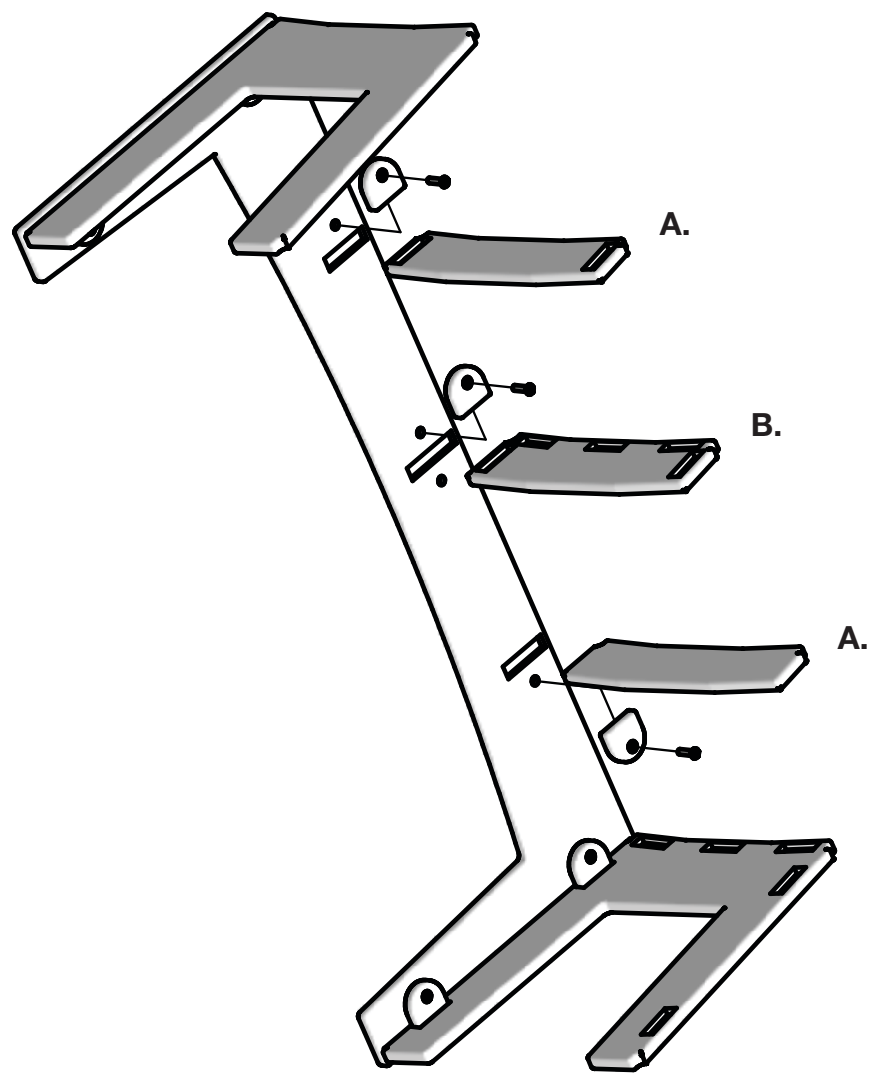

**A.** Fit short edge of the Small Ribs into the Side's outer pocket cut outs with the Ribs pocket cut out facing the threaded hole in the Side. Place Blocks G into the Rib's pocket cut outs, insert bolts through the blocks into the Side's threaded holes, and finger tighten.

**B.** Fit short edge of the Large Ribs into the Side's center pocket cut outs with the Ribs pocket cut out facing the threaded hole in the Side (for 47" an additional hole is provided making Rib direction universal). Place Blocks G into the Rib's pocket cut outs, insert bolts through the blocks into the Side's threaded holes, and finger tighten. (2 Large Ribs for 58" Bench.)

## 3 ATTACH ATTACH CENTER SEAT SLAT

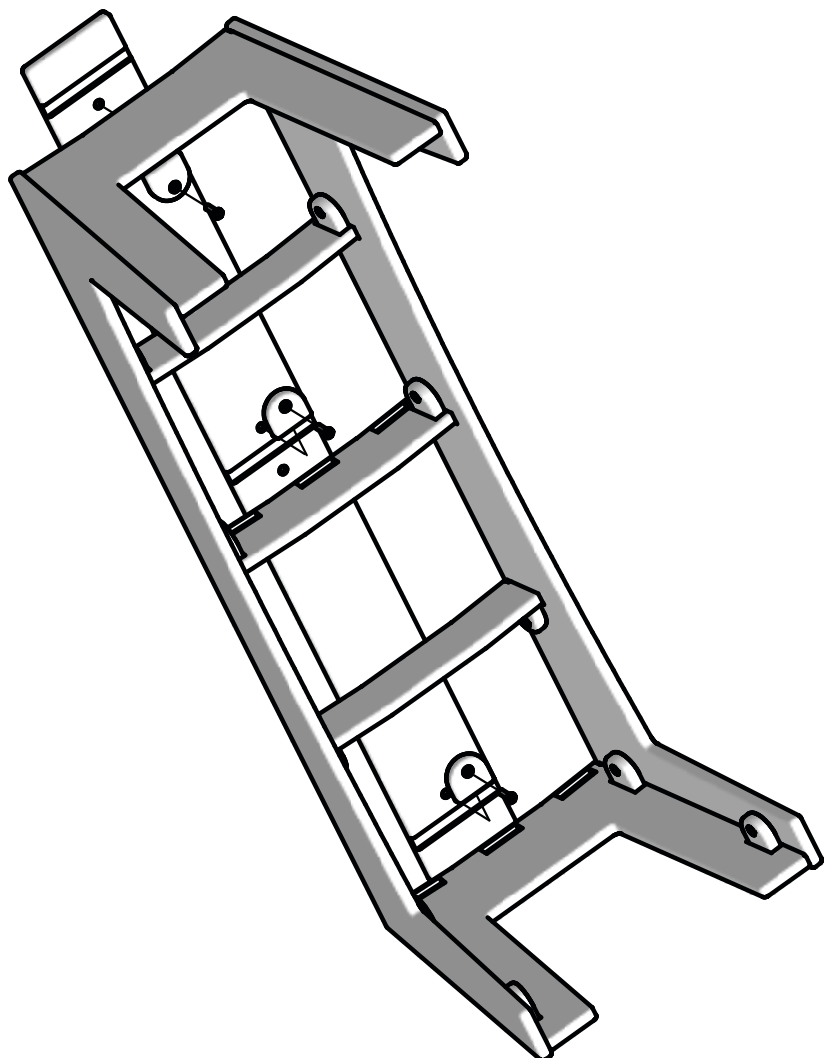

Attach opposite Side using steps 1-2.

Fit center Seat Slat (B) groove track cut outs over Ends, Small Ribs, and Large Rib(s) and align to center of bench. Place Blocks G into the Rib's and End's pocket cut outs, insert bolts through the blocks into the Seat Slat's threaded holes, and finger tighten.

## 4 ATTACH OUTER SEAT SLATS

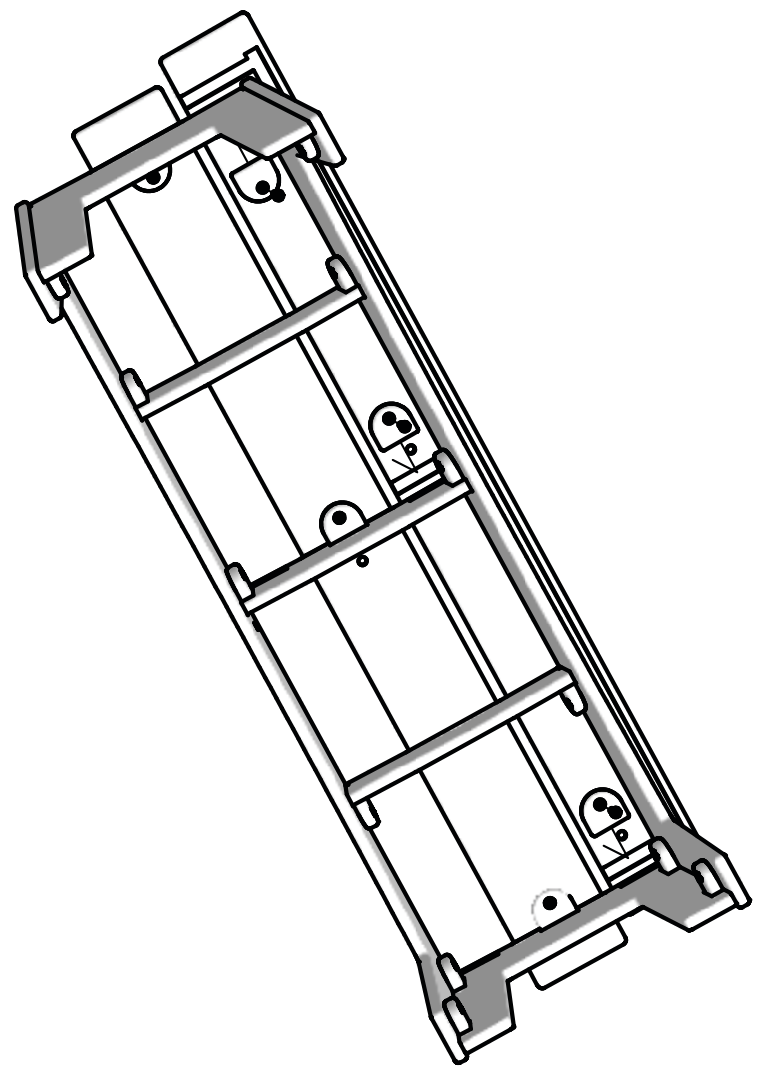

Fit end Seat Slats (A) groove track cut outs over Ends, Small Ribs, and Large Rib(s). Place Blocks G into the Rib's and End's pocket cut outs, insert bolts through the blocks into the Seat Slat's threaded holes, and finger tighten.

\*Using provided wrench securely tighten all bolts.

**DAMAGED PRODUCT**

Sometimes accidents occur. Please inspect your Loll furniture when you receive it to make sure that it has not been damaged during shipping. If damage has occurred please take digital pictures of the damaged furniture and the box it was shipped in, and email them to sales@loll designs.com or call Customer Service using our toll free number: 877.740.3387, ext. 1. The damage will be assessed and you will be contacted with a solution to the problem. It may be helpful to save all of your packaging material in case a return is necessary.



**ASSEMBLY TIPS**

*\*Please read before beginning assembly!*

To avoid damaging furniture perform the assembly of your Loll furniture on a clean soft surface like a blanket, carpet, or the flattened cardboard box the furniture was shipped in. Components should not be unnecessarily forced together! If it seems parts aren't fitting together you likely have something wrong and you should reread the instructions to ensure you are aligning the proper components. If your piece of furniture requires "Blocks" for assembly one side may have protective film on it. This surface is hidden after assembly so the film can remain on the block or it can be removed. Use a Cordless Screw Gun if you have one and know how to use it. Set the clutch setting at medium torque. We do not recommend using an electric drill with a cord and without a clutch to install bolts in inserts as you can easily overtighten and damage the product. All bolts come standard with a thread coating to reduce bolts loosening after assembly while still allowing removal and reuse of the bolt. Start all bolts by hand, with the Allen Key, or the Loll Tool and tighten firmly until parts are drawn tight together and you can't muscle the bolt any tighter. It's virtually impossible to over tighten by hand. Watch the assembly videos at [www.lolldesigns.com/videos](http://www.lolldesigns.com/videos) for even more information and visual aids. If you have more questions please contact your Loll Sales Associate or Customer Service for support at 877.740.3387. A **Pro Tool Kit** can also be purchased from Loll for multi piece assembly jobs.

**\*\* Please Recycle the BOX and paper packaging. The green plastic stretch wrap we use is compostable.**



Scan for assembly tips and videos



**BLOCK & BOLT INSTALLATION**

Insert bolts through countersunk hole side of blocks as shown below.

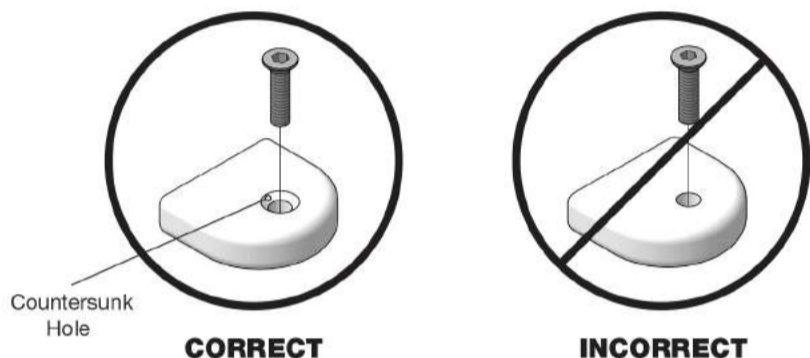

**CORRECT**

**INCORRECT**

**LOLL TOOL**

Locate the box marked "Tool Included" before beginning assembly.



**We want you to love your Loll.**

Reach out if you need lollygagging assistance.  
877-740-3387  
sales@loll designs.com  
5912 Waseca Street | Duluth, Minnesota 55807



**ASSEMBLY INSTRUCTIONS & PRODUCT INFO: ALFRESCO BENCH 68" & 81"**

Loll Designs inspires people to appreciate the outdoors.

**PRODUCT CARE**

Your new Loll furniture is a no maintenance product. You'll never need to paint or stain it and it can be left outside all year regardless of the season. It will not rot, even if left standing in water. Nonetheless, we're pretty sure your Loll furniture will get a lot of use and will at some point need cleaning. We recommend a garden hose and incorporating a soft bristle brush. Adding a tablespoon or two of your favorite eco-friendly soap to the wash will get everything squeaky clean. Mineral deposits left over from hard water can be removed with a solution of vinegar and water. Loll offers a cleaning kit that has everything you need for great results. Also see our cleaning video at [lolldesigns.com/videos](http://lolldesigns.com/videos).

**5 YR WARRANTY**

Loll Designs strives to build long-term relationships based on confidence and trust with our customers. We sit beside, on top, and beneath the quality of our fine furniture and will make things right if you are not completely satisfied with your purchase. Loll Designs hereby guarantees that the piece will be of good quality and workmanship, free from faults and defects. Loll warrants that all components will not fail, under normal use, for five years from the year mark on the piece or the date of purchase. \*For commercial orders the warranty is three years.

**SHARE YOUR LOLL**



lolldesigns.com  
877.740.3387



**INCLUDED PARTS**

SIDE		COUNT	SIDE SLAT		COUNT	MIDDLE SLAT		COUNT	
		<b>2</b>			<b>2</b>			<b>1</b>	
SIDE BRACE		COUNT	END		COUNT	2 SLOT BRACE		COUNT	
		<b>2</b>			<b>2</b>			<b>2</b>	
		COUNT	5 SLOT BRACE		COUNT	COUNT			
					<b>3</b>	<b>4</b>			
					68"	81"			
BLOCK G		COUNT	COUNT	1.375" BOLT		COUNT	COUNT	1" BOLT	
		<b>29</b>	<b>34</b>			<b>10</b>	<b>12</b>		
		68"	81"			68"	81"		
								<b>8</b>	

# ASSEMBLY INSTRUCTIONS

\* It is very important that you finger tighten all bolts into inserts to ensure that you do not cross-thread bolts and inserts before tightening. It will also be easier if you wait to tighten bolts until you have all bolts installed and the piece completely assembled. This will allow for more movement of individual pieces and help in aligning holes with inserts. Use the Allen Tool provided to finish tighten bolt until snug.

## 1 FIT ENDS AND SIDE BRACE TOGETHER

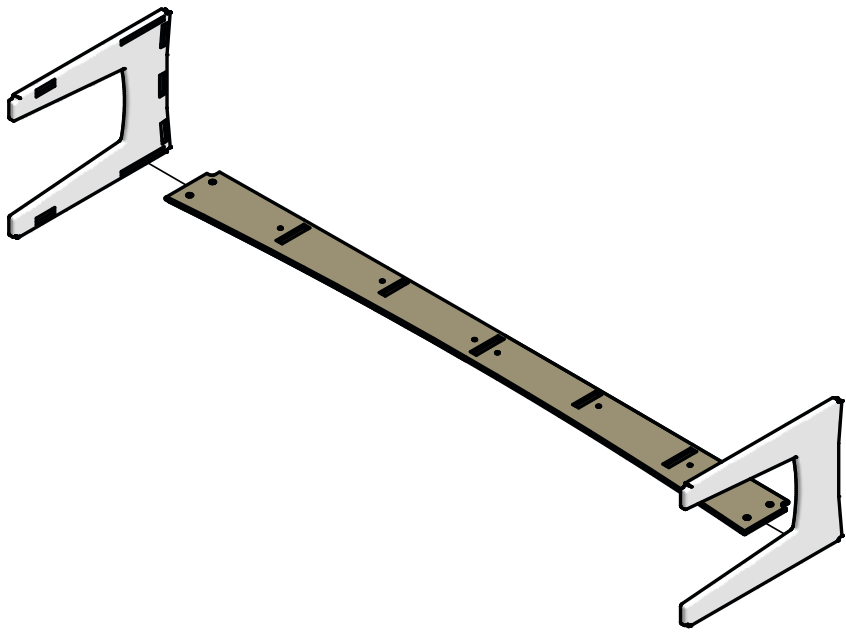

\*Please read Assembly Tips before beginning assembly.  
Fit Side Brace edges into the pocket cut outs of the Ends.

## 2 ATTACH SIDE

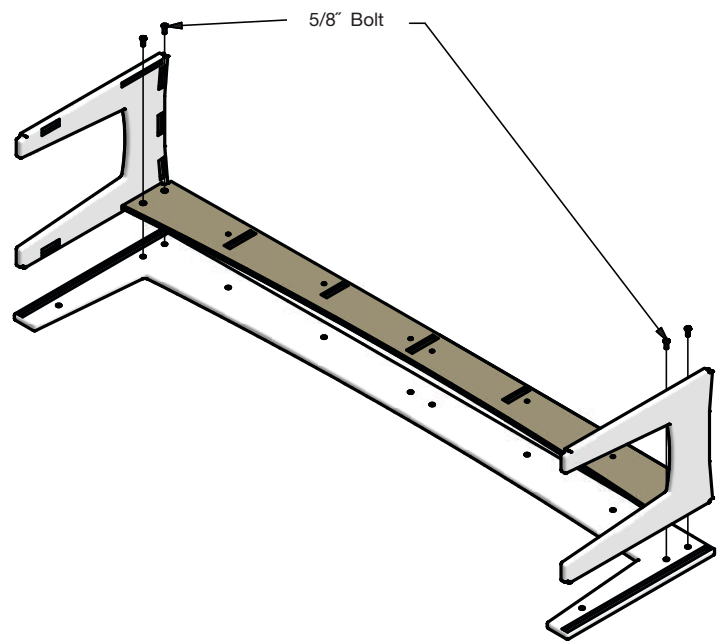

Fit Side Brace and Ends with the Side by fitting the Ends long edges into the Sides groove track cut outs. Insert 5/8" bolts through the Side Braces holes into the Sides threaded holes and finger tighten.

## 3 FASTEN SIDE

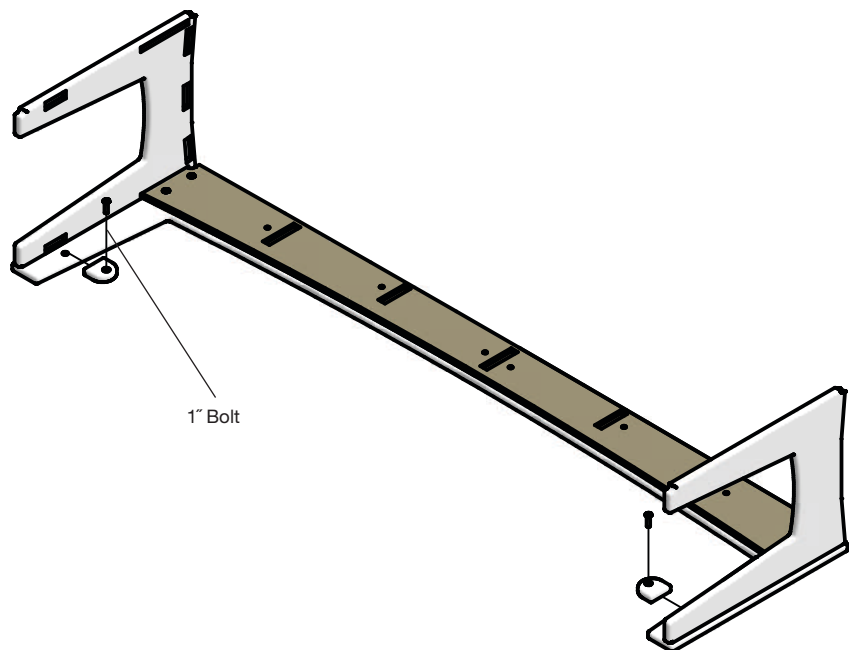

Place Blocks G into the Ends pocket cut outs (recessed hole side up), insert bolts through the blocks into the Ends threaded holes, and finger tighten.

Repeat Steps 1-3 to attach other side.

## 4 ATTACH BRACES

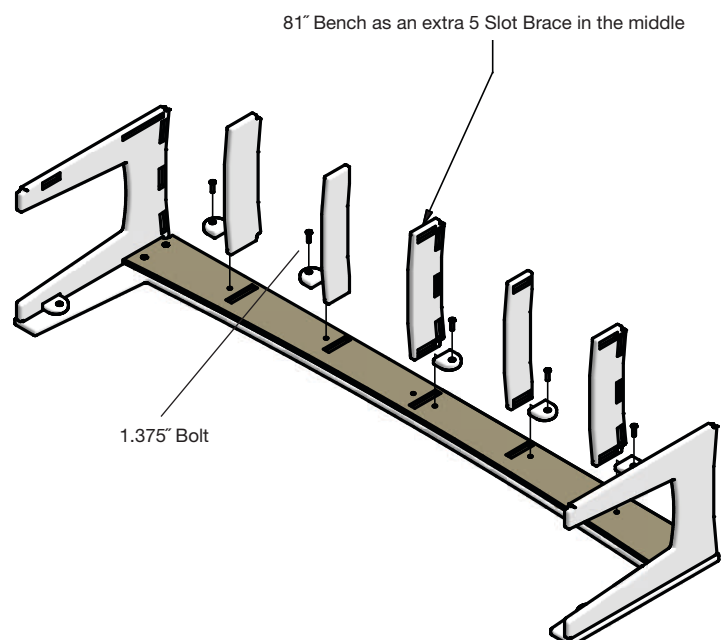

Fit 5 Slot Braces in the outer and center Side Brace pocket cut outs (for 81" bench an additional 5 Slot Brace is needed in the center) with the pocket cut out of the 5 Slot Brace facing the threaded holes of the Side Brace (68" version has two threaded holes for center brace. One will be used and the other left open). Fit 2 Slot Braces in the inner Side Brace pocket cut outs. Place Blocks G into the Slot Brace cut outs, insert bolts, and finger tighten. Repeat Steps 1-4 to attach other side.

## 5 ATTACH SIDE SLAT

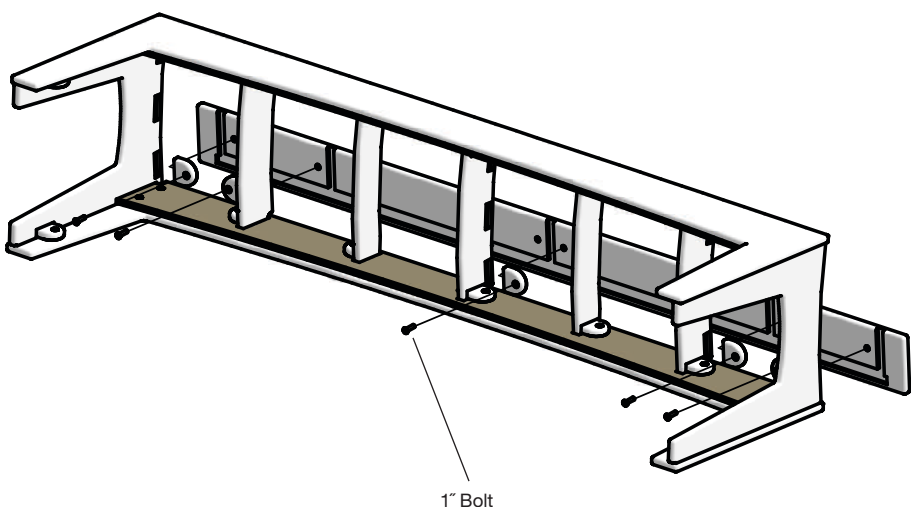

Fit groove track cut outs of the Side Slats with the assembled Side and Braces. Place Blocks G into the 5 Slot Brace pocket cut outs, insert bolts, and finger tighten.

## 6 ATTACH MIDDLE SLAT

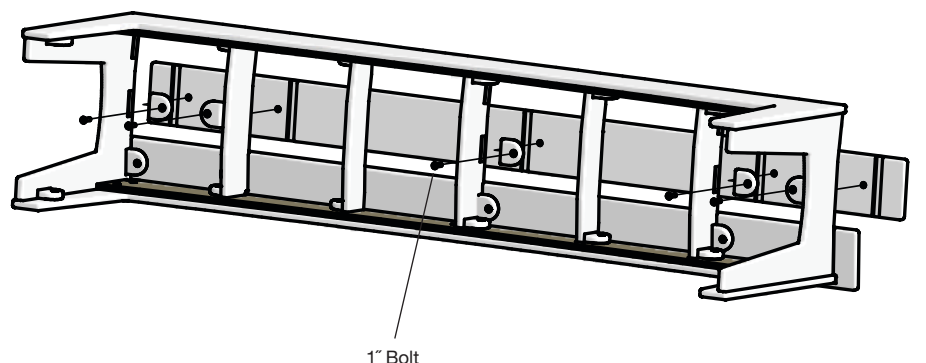

Fit groove track cut outs of the Middle Slats with the assembled Ends and Braces. Place Blocks G into the 5 Slot Brace pocket cut outs, insert bolts, and finger tighten. Repeat Step 5 to attach other Side Slat.

\*Using provided wrench securely tighten all bolts.