

HAMILTON 

Innovative Solutions for Process Analytics

in Biotechnological and Pharmaceutical Industries



Continuous Process Improvement

More measurement parameters and less measurement error yield tighter process control



Take advantage of our demonstration program to see firsthand how the right sensor can improve your process

Process Understanding

Hamilton maintains an intense focus on new technologies that address the upcoming needs of our biopharmaceutical customers. Our goal is to provide new online sensing technologies that are robust and provide actionable data to improve process understanding.

Process Improvement

It is not always simple to evaluate new sensor technologies. The cost of performing a validation is second only to the paperwork involved. Hamilton helps with innovations to existing and new parameters that improve reliability and consistency while reducing cost.

Process Control

Bringing offline measurements online provides more data points and results in more accurate monitoring of critical control parameters. Deviations can be addressed in real time resulting in higher product yield.

Get the Most Out of Your Sensors

Schedule a lunch and learn to find out how to benefit from the innovations below. Learn tips and tricks for properly maintaining and calibrating sensors, or dig deeper into specific problems that are being faced at your facility.





Tomorrow's Innovations

Coming soon: new online sensors for common offline measurements



Single Use pH Sensor

No preparation, sterilization, or calibration by customers; gamma sterilizable sensor capable of dry storage

2015

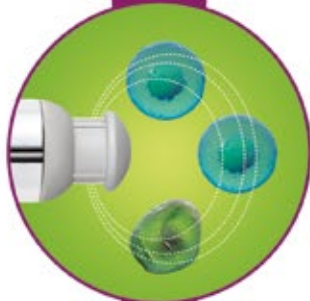

Online Viable Cell Density

Process optimization and control based on real-time measurement of viable cells

2014



Intelligent Sensors

Integrated transmitter reduces installation, troubleshooting, and calibration costs

2010



Optical Oxygen Sensors

No polarization reduces maintenance and troubleshooting time

2007



Prepressurized pH Sensors

6 bar internal pressure minimizes reference and process contamination

2004



Glass Formulations

Stability at 140°C increases life with CIP, SIP, and autoclaving

1989

The Intelligent Sensor Revolution

Over 95% of process engineers surveyed find value in using smart sensors

Less than half of engineers felt they fully utilized their smart sensor. The key to getting the most out of your smart sensor is choosing the implementation that best fits your application. Hamilton offers two versions of smart sensors each equipped with our best-in-class measurement technology.

Cost Comparison

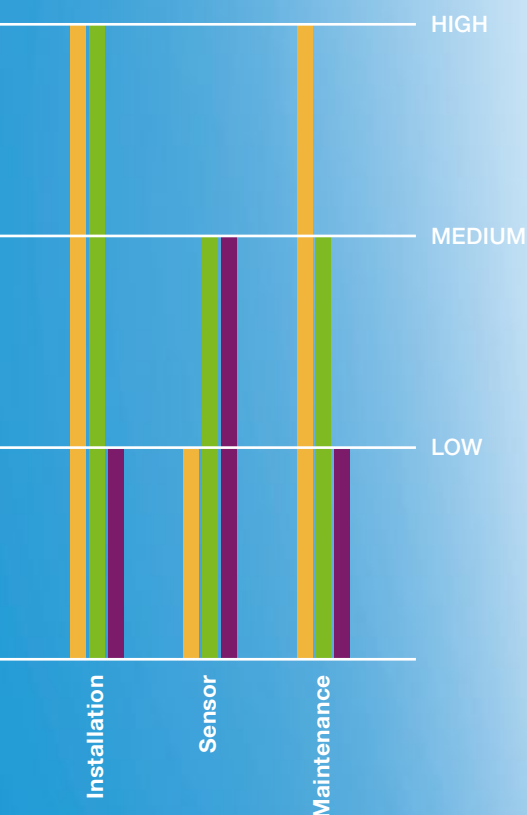

▶ Analog Sensors

Traditional analog sensors offer the lowest sensor cost which is ideal for implementations that discard the sensor after each run. They rely on a transmitter to read the sensor's electrochemical signal (ECS) and transmit it to the process control system.

▶ Digital Sensors Memosens and Dencytee

Digital sensors eliminate signal errors from electromechanical noise near the cable and reduce maintenance cost by enabling in-lab calibration instead of at-line. This is accomplished with an integrated processor to convert the electrochemical signal to a digital output.

▶ Intelligent Sensors

Arc Sensors, VisiPro, and VisiTrace

Intelligent sensors have the lowest start-up and operating costs. They provide advanced alarms, troubleshooting, quality indicators, and diagnostics simultaneously to the control system and to an optional mobile device. An integrated micro-transmitter eliminates a point of failure by directly connecting the sensor to the PCS.

Workflow

Analog pH Sensor

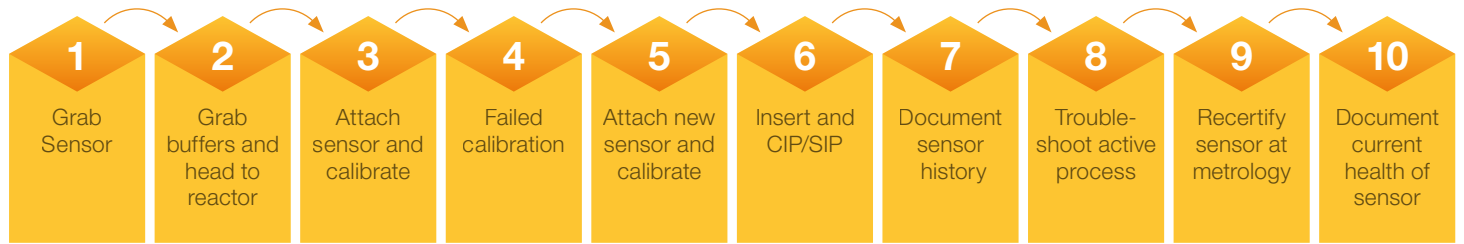

Lower Operating Costs

Transmitters are large and bulky, requiring them to be permanently installed at-line. Intelligent sensors have an integrated transmitter thanks to advances in microprocessors. The result is a profound improvement in the sensor handling workflow.

- Reduce installation costs by eliminating transmitters
- Calibration can happen anywhere and can be batched to reduce cost
- Current and historical data is used to predict sensor health so a failed sensor is never discovered at-line
- Minimize documentation workload with automatic reports
- Simplify troubleshooting with sensor specific warnings that are accessed wirelessly

Intelligent pH Sensor

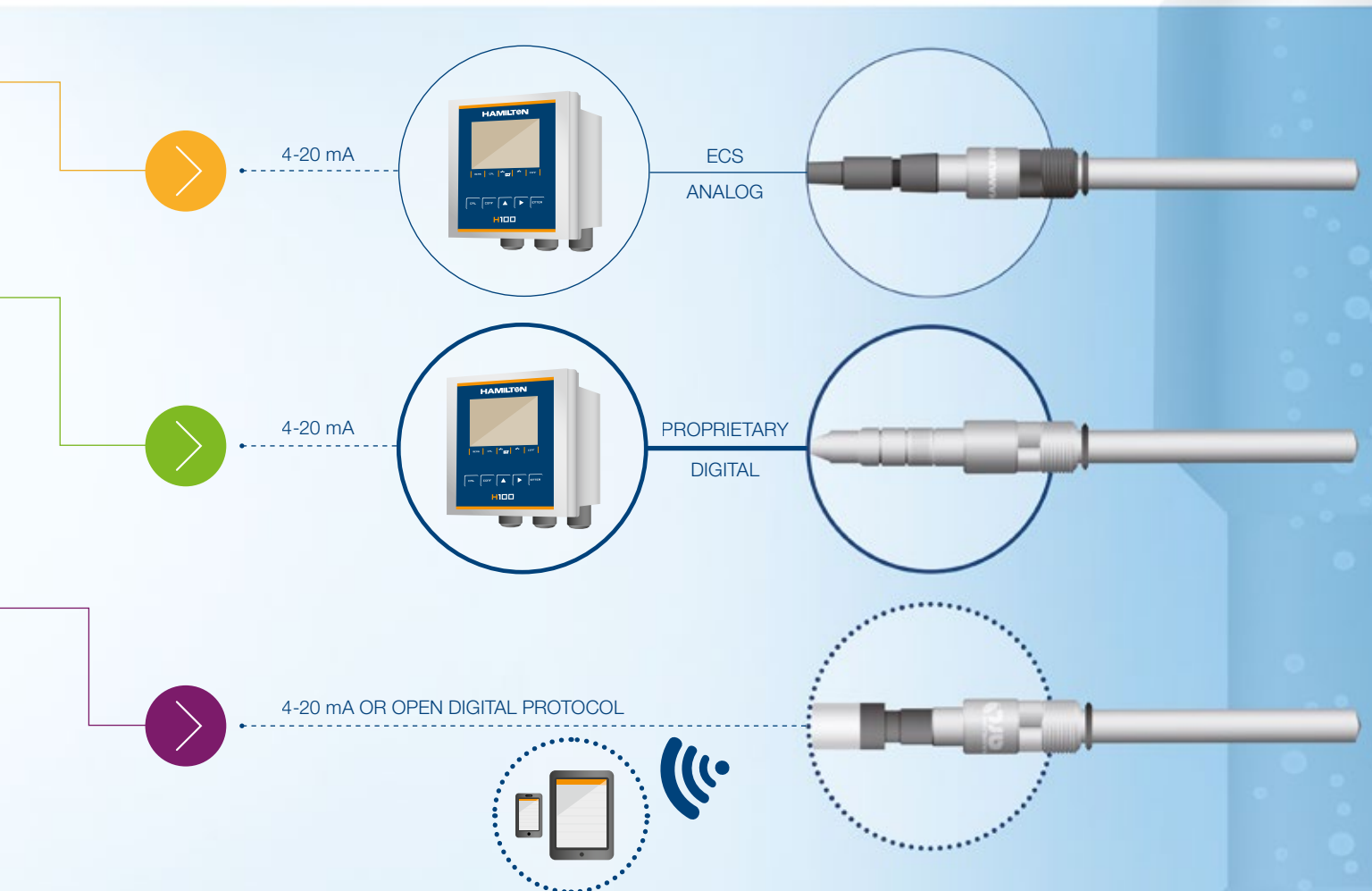
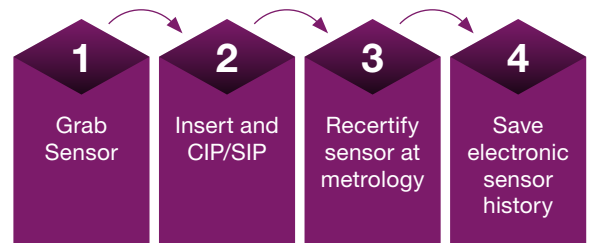

A Trusted Partner



R&D

The top bioreactor manufacturers deliver reactors with Hamilton sensors installed

Bioreactor performance is dependent on having reliable access to actionable data. Manufacturers choose Hamilton's diverse product offering to deliver to their customers relevant process parameters with exceptional life and low maintenance.

Retrofitting Existing Bioreactors

Hamilton offers sensors that are compatible with any bioreactor and provide improved measurement stability and sensor life. Upgrading to an intelligent sensor will lower operating costs with automatic reporting, batched in-lab calibration, quality indicators, and wireless troubleshooting.

Next Generation Bioreactors

In recent years bioreactor manufacturers have incorporated 4–20 mA inputs to enable direct input from intelligent sensors. Now they are taking the next step by incorporating digital control of the sensors. This enables the user to check the sensor health, calibrate, and troubleshoot all from the reactor controller.

New Tools



Viable Cell Density (VCD)

Incyte Arc Sensors

Cell counting and trypan blue staining, as well as other offline measurements of viable cell density are labor intensive, prone to contamination, and provide limited data. Instead of two measurements per day Incyte provides continuous data resulting in faster optimization of feeding and harvesting strategies.

Total Cell Density (TCD)

Dencytee Sensors

Most Optical Density probes lose linearity as cell density increases. Dencytee's variable NIR light source increases intensity to maintain sensitivity with low- and high-density cultures.

Single-use pH and DO

Hamilton developed a gamma sterilizable glass pH sensor that arrives factory calibrated and can be stored dry for up to 18 months. This can be delivered in the bag ready to use alongside Hamilton's single-use optical dissolved oxygen spot.



ArcAir for Smartphones and Tablets

Turn any Bluetooth 4.0 iOS or Android device into a troubleshooting tool for free. ArcAir Lite connects via Bluetooth and provides access to all sensor data. Upgrade to ArcAir Basic or Advanced to adjust sensor settings, perform calibrations, and generate calibration and validation reports.



Seamless Scale-up to Production

A worker in a white protective suit, blue gloves, and a white face mask is operating a piece of industrial machinery. The worker is leaning forward, holding a control lever. The background shows a clean, industrial environment with various pipes and equipment. A large, dark red diagonal graphic element is overlaid on the bottom right of the image.

Sensors that last longer and require less maintenance

Hamilton is known for high quality materials and craftsmanship that result in exceptional sensor life. With the introduction of the Arc sensors Hamilton took ownership of the measurement loop and pioneered advances in sensor calibration, troubleshooting, connectivity, and documentation.



Start Up

Hamilton assists you to better understand the functionality and use of your sensors with a familiarization demonstration. Trained service engineers are available to commission, qualify, and verify your sensor installation and deliver audit-quality reports that can be shared with your regulatory body.

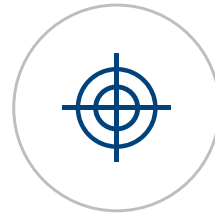

Calibration

On-site calibrations require a lot of preparation and logistic effort. Arc sensors can be calibrated in the lab and stored ready to use on the shelf.



Cleaning

Cleaning in Place (CIP) and Sterilization in Place (SIP) are very challenging treatments for the functionality of sensors. Hamilton sensors are engineered to achieve no offset and no drift shortly after cleaning.



Maintenance and Troubleshooting

Wirelessly troubleshoot up to 30 sensors at a time without having to enter the production environment. The sensor's quality indicator as well as errors and warnings are easily accessible via the ArcAir App on the Arc View Mobile.



Plant Expansion

Arc sensors eliminate the need for costly transmitters and simplify wiring with a variety of analog and digital communication options.



Documentation

Best practices require documentation of sensor calibration, communication verification, and post-process sensor verification. This is normally a manual process, but with Arc reports are generated automatically. The reports are saved in the GMP compliance database, printed, and signed for compliance records.

Product Offering

Equipment, sensors, and accessories for complete loops

For more than 25 years, Hamilton has developed sensors, housings, and buffers to meet the evolving needs of pharmaceutical and biotechnology customers. Our extensive product selection is certified to meet or exceed all FDA and GMP regulatory standards.



Measurement Parameters

All relevant measurement parameters for BioPharma applications are part of the Hamilton portfolio.

Electrical Connectors

Regardless of which electrical connector, analog or digital, Hamilton provides sensors with the compatible head.



Analog

Digital

Intelligent

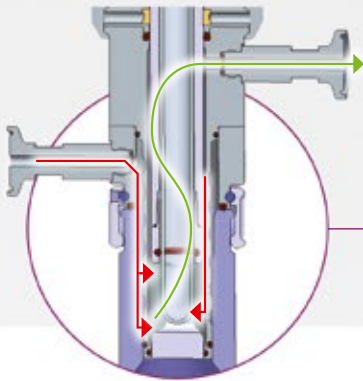

Process Insertions

Sensors can only perform as they ought to with the appropriate process connection or housing. Hamilton housings are designed to fulfill all cleanability and sterilization requirements. If special solutions are required, Hamilton's application engineering team is more than happy to develop a customized solution.



Calibration & Validation

All calibration procedures assume that the labeled values of the calibration buffers are correct. But buffer values can change over time and so can the results. A complete range of patented buffer solutions provides pH stability up to 5 years, something never achieved before.

Low conductivity measurements require reliable calibration standards. Since a conductivity standard is not a buffer solution, the lower the value of the conductivity standard, the greater the effect of contamination and CO₂. Hamilton is the first manufacturer of patented conductivity standards of 1.3 and 5 μS/cm with certified accuracy and a long lifetime.

Hamilton offers a wide range of calibration buffers for pH and ORP as well as conductivity standards, suitable for use under GMP, GLP, ISO 9001, and EN 45000 regulations. Traceability is ensured through an unbroken chain of comparison to reference material of the highest metrological quality from NIST* and PTB**.



Documentation

Hamilton products have to pass a quality test and are shipped with a Declaration of Quality and, where applicable, with further documents like an EN 10204 3.1 certificate for stainless steel. Additionally a GMP compliance package for Arc sensors, a validation software that provides simple management functionality of user profiles and validation reports for calibration, verification, configuration, and communication is available.

*National Institute of Standards and Technology, USA | **Physikalisch Technische Bundesanstalt, Germany

Biopharmaceutical Roadmap

Every step of the biopharmaceutical process has specific requirements for sensors to monitor and control it precisely. The roadmap below shows the individual recommendations from the Hamilton portfolio.

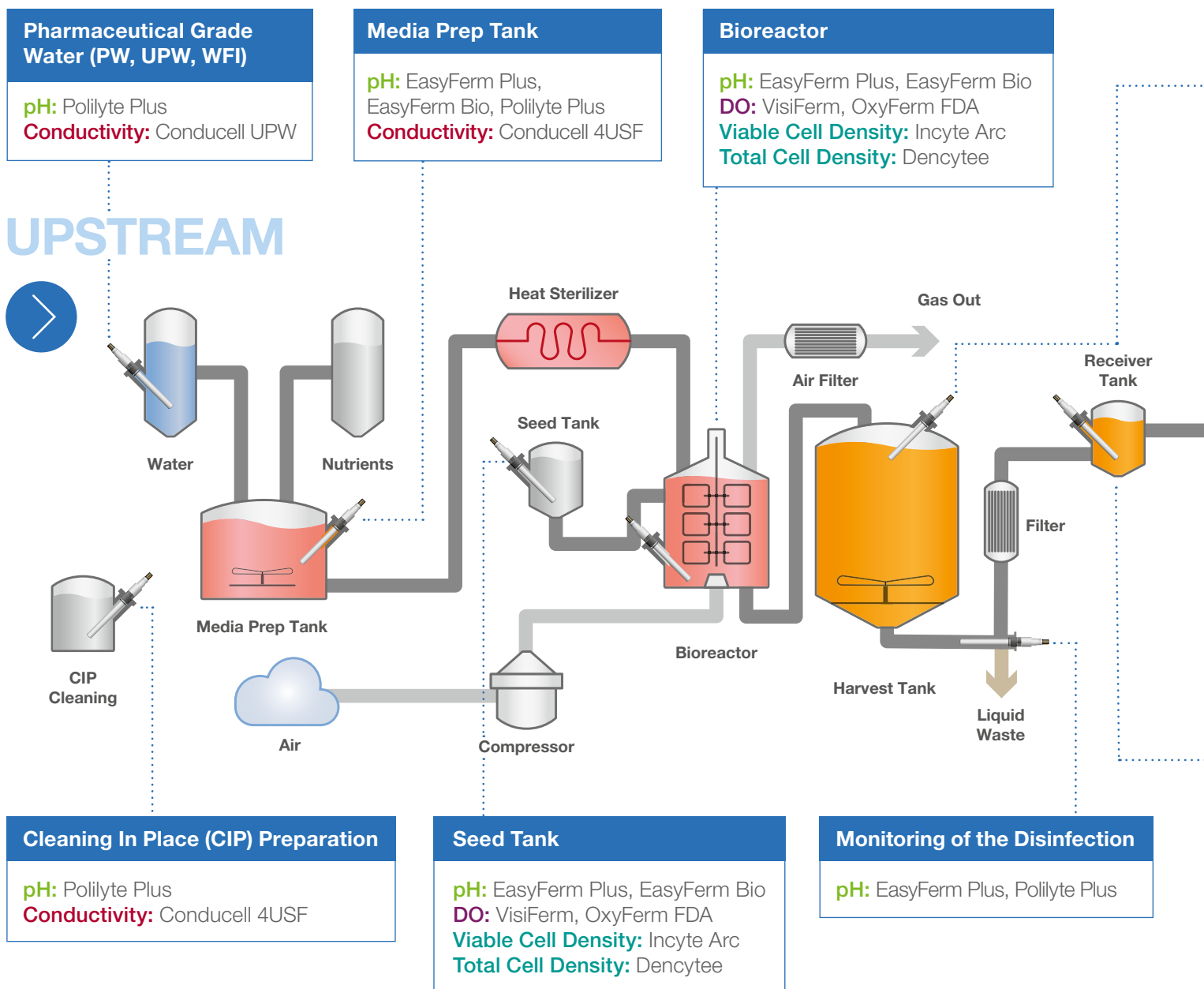



Harvest Tank
pH: EasyFerm Plus, EasyFerm Bio
DO: VisiFerm

Centrifuge
DO: VisiFerm

Ion Exchange Chromatography
pH: EasyFerm Plus, Polilyte Plus
Conductivity: Conducell UPW (water),
Conducell 4USF (buffer)

DOWNSTREAM

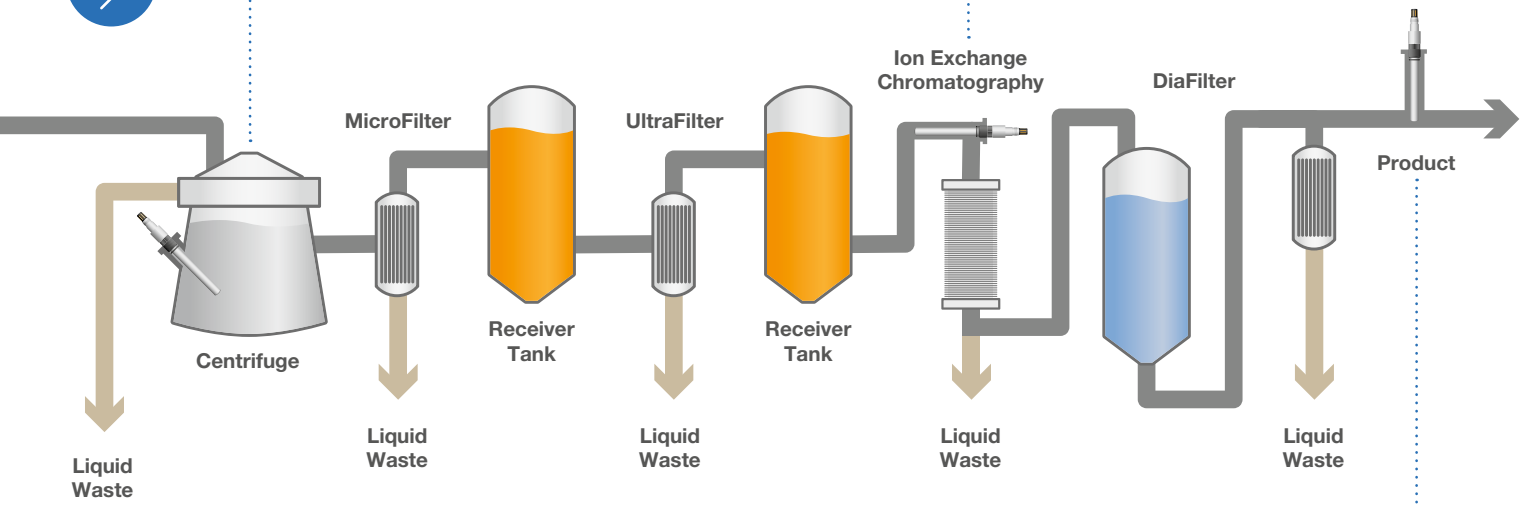

Receiver Tank
pH: EasyFerm Plus, EasyFerm Bio
DO: VisiFerm

Pure Product Stored Prior to Packaging
pH: EasyFerm Plus

Sensor Families



EasyFerm Plus / Bio

The EasyFerm Plus and Bio families of pH and ORP sensors are ideal for biotech applications, like fermentations, where autoclavations, steam sterilisations (SIP), and cleaning in place (CIP) procedures occur frequently. Available with the innovative Arc technology.

BENEFITS

- Stable measurement signals after steam sterilization, autoclaving, and CIP
- Drift-free measurement
- Ceramic diaphragm
- Wetted parts according to USP class VI
- Available as ORP sensor
- EasyFerm Bio is bio-compatible with EHEDG



Polilyte Plus

The outstanding success of the Polilyte Plus in chemical and wastewater applications gave the inspiration to enhance the whole family of sensors. The expanded portfolio widens the range of applications that can be covered. All members will have the same reference electrolyte Polisolve Plus and use the Single Pore technology but will have different pH glasses.

BENEFITS

- Greater variety of applications due to different pH glasses
- No clogging due to single pore technology
- Highly reproducible measurements
- Very stable over long periods of time
- Upside-down mounting possible with VP connector head
- Available as ORP sensor





VisiFerm DO

The VisiFerm is the first optical process sensor for the measurement of dissolved oxygen in biotech and pharma applications. It has significant advantages compared to classical Clark cells. It's designed for applications where SIP, CIP, and autoclavations are carried out frequently. Available with the innovative Arc technology.

BENEFITS

- Robust design for steam sterilization, autoclavation, and CIP
- Self-diagnostics
- Electrolyte-free
- No polarization time required
- Easily replaceable sensor cap
- Digital and analog (4–20 mA) signal output
- ECS-mode available (Clark cell simulation)



OxyFerm FDA

The OxyFerm family of electrochemical (amperometric) oxygen sensors is designed for use in biotechnology applications. Available in different shapes and the innovative Arc technology.

BENEFITS

- Robust design for steam sterilization, autoclavation, and CIP
- 12 mm or 25 mm shaft (XL) diameter available
- Various O-Ring positions for the XL-version available
- Polarization module available



Sensor Families

Incyte Arc

The Incyte sensors enable real-time, online measurement of viable cells in mammalian cell culture, yeast, and high-density bacterial fermentation. Online measurement allows detection of events and response in real-time without sampling.

BENEFITS

- Insensitive to media changes, microcarriers, dead cells
- Detect changes in physiology with frequency scanning
- Early detection of deviations without sampling
- Increase yield and lower production costs



Dencytee

The Dencytee sensors perform online measurement of total cell density based on optical density at NIR (near infra-red) wavelengths. The measurement is effective at low cell concentrations.

BENEFITS

- Insensitive to changes in media color
- Reliable values during the growth phase
- Early detection of process deviations



Arc View Controller

The Arc View Controller is used to collect and record data generated by the Dencytee sensors. Arc sensors, such as pH and dissolved oxygen, can be wirelessly recorded to view all relevant parameters from a single screen. Licenses required.



BENEFITS

- Record, display, and export measurement data
- Data output as 4–20 mA, OPC, or Modbus
- Store calibration data for multiple sensors
- Two or four channel controllers available



Conducell 4UxF

The Conducell 4UxF family of 4-pole conductivity sensors is suitable to measure a broad range of conductivities with excellent linearity. Typical applications are monitoring of CIP cleaning and chromatography. Available with the innovative Arc technology.

BENEFITS

- Robust design for steam sterilization, autoclavation, and CIP
- All wetted parts are FDA-compliant
- Very easy to clean due to the forward-facing, flush arrangement of electrodes
- EHEDG-certified with Hamilton's hygienic socket
- Available pole materials: stainless steel, Hastelloy C, and titanium
- Various process connections available: PG 13, 5, Tuchenhagen VariVent, BioConnect, and Triclamp



VP 6

Arc



Conducell UPW

The Conducell UPW (Ultra-Pure Water) 2-pole conductivity sensors are designed for the use in liquids with very low conductivity, i.e. Ultra-Pure Water (UPW), Pure Water (PW), Water For Injection (WFI), particularly in the pharmaceutical industry. Available with the innovative Arc technology.

BENEFITS

- Monitoring of ultra-pure water according to USP 645 with two alarm outputs
- All wetted parts are FDA-compliant
- Shaft diameters 17 and 12 mm available
- Various process connections available

Arc TC 1,5"

Arc PG 13,5

VP 6



Housings

Retractex B

Retractex B housings are designed for sanitary applications in biotechnology, food & beverage, and pharmaceutical industry and require low maintenance. The Retractex B with its patented HyCIP cleaning principle offers the best available cleaning efficiency for Ingold sockets.



BENEFITS

- All major process connections available: Ingold (G1¼), Triclamp, Varivent, DIN 11851
- Pneumatic or manual drive
- Integrated safety concept: no sensor—no insertion
- Very low maintenance



FlexiFit

FlexiFit static housings are designed for 120 mm sensors.



BENEFITS

- All major process connections available: Ingold (G1¼), Triclamp, Varivent
- Available with or without protecting rods
- Angled versions available (15°)
- Various O-Ring positions available



FlowCell

FlowCells are flow-through armatures. They can be used in all cases where pH, DO, conductivity, or even two of them must be reliably measured in chromatography media, as well as in cooling piping in power generation stations.



BENEFITS

- Flexible design for one or two parameters
- PEEK insert of high chemical resistance
- Low dead volume
- Self draining
- Internal aseptic clamp pipe connection

Calibration

pH Buffers

A complete range of buffer solutions provides never before achieved pH stability. Hamilton guarantees that Duracal pH buffers will be stable for years after the date of manufacturing. Primary and secondary standards are used for the calibration of the devices and the manufacturing of the buffers.

BENEFITS

- pH 1.09 to pH 12.0 available
- Stability for up to 5 years
- All buffer solutions certified by external laboratory (DAkkS) and traceable to NIST
- Built-in compartment for very convenient calibrations



Conductivity Standards

Hamilton is the first manufacturer to offer conductivity standards in 1.3 and 5 $\mu\text{S}/\text{cm}$ with a certified accuracy of $\pm 1\%$. Repeated use is possible if the bottle is not open for more than 1 h in total.

BENEFITS

- Wide range from 1.3 $\mu\text{S}/\text{cm}$ to 100 mS/cm available
- Long time stability up to 3 years
- Range from 1.3 $\mu\text{S}/\text{cm}$ to 12,880 $\mu\text{S}/\text{cm}$ certified by the Danish Institute of Fundamental Metrology and traceable to NIST



©2019 Hamilton Bonaduz A.G. All rights reserved.
All other trademarks are owned and/or registered
by Hamilton Company in the U.S. and/or other countries.

REF 691123/03 — 06/2019

HAMILTON 

Web: www.hamiltoncompany.com

USA: 800-648-5950

Europe: +40-58-610-10-10

Hamilton Americas & Pacific Rim

Hamilton Company Inc.
4970 Energy Way
Reno, Nevada 89502 USA
Tel: +1-775-858-3000
Fax: +1-775-856-7259
sales@hamiltoncompany.com

Hamilton Europe, Asia & Africa

Hamilton Bonaduz A.G.
Via Crusch 8
CH-7402 Bonaduz, Switzerland
Tel: +41-58-610-10-10
Fax: +41-58-610-00-10
contact.pa.ch@hamilton.ch

To find a representative in your area, please visit www.hamiltoncompany.com.