

QHW ELECTRONIC WEIGHING SCALE

PA Cert. Number : **ATS-0064-21**

FEATURES

- Function include check weighing, counting, percentage, accumulation and weighing unit conversion.
- Check Weighing Function (Option to set hi/low limit for weighing, counting and percentage)
- Up to 70 hours of continuous use through battery supply (without backlight)



OPTIONS

- RS-232 Interface

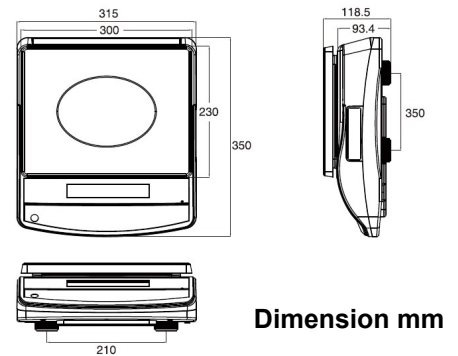

SPECIFICATIONS

Art No.	QHW-6K	QHW-15K	QHW-30K
Capacity Dual Range	3kg/6kg x 1g/2g	6kg/15kg x 2g/5g	15kg/30kg x 5g/10g
Display	24mm Digit LCD Display With White LED Backlight		
Division	2 x 3000e Min 20e		
Pan Size	230 x 300mm		
Dimension (L x W x H)	350 x 315 x 118.5mm		
Keyboard	7 Keys (Membrane Keyboard)		
Operate Temp.	-10 °C ~ +40°C		
Class	III		
ADC	Sigma Delta		
ADC Update	≤ 1/10 Second		
Housing	ABS Plastic		
Power	AC Adaptor (12V/500mA), Internal Rechargeable Battery (6V/4Ah)		
Gross Weight	5.1Kg		