

QHW ELECTRONIC WEIGHING SCALE

FEATURES

- Function include check weighing, counting, percentage, accumulation and weighing unit conversion.
- Check Weighing Function (Option to set hi/low limit for weighing, counting and percentage)
- Up to 70 hours of continuous use through battery supply (without backlight)



OPTIONS

- RS-232 Interface

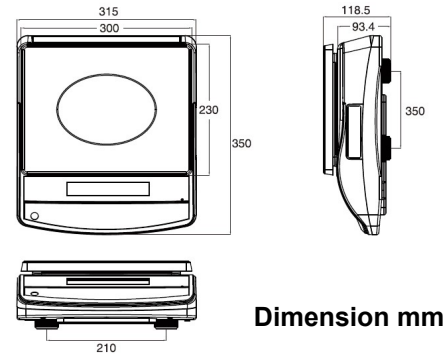

SPECIFICATIONS

Art No.	QHW-30K+	QHW-30K++
Item No.	01TS-D-WS010	01TS-D-WS011
Capacity	30Kg x 0.5g	30Kg x 0.2g
Display	24mm Digit LCD Display With White LED Backlight	
Max. Divisions	30'000d	150'000d
Pan Size	230 x 300mm	
Dimension (L x W x H)	350 x 315 x 118.5mm	
Keyboard	7 Keys (Membrane Keyboard)	
Operate Temp.	-10 °C ~ +40°C	
ADC	Sigma Delta	
ADC Update	≤ 1/10 Second	
Housing	ABS Plastic	
Power Source	AC Adaptor (12V/500mA), Internal Rechargeable Battery (6V/4Ah)	
Gross Weight	5.1Kg	