

AHW ELECTRONIC WEIGHING SCALE

FEATURES

- Function include unit conversion, simple parts counting, check weighing, percentage weighing
- Check Weighing Function (Option to set hi/low limit for weighing, counting and percentage)
- Up to 70 hours of continuous use through battery supply (without backlight)



OPTIONS

- RS232 Interface

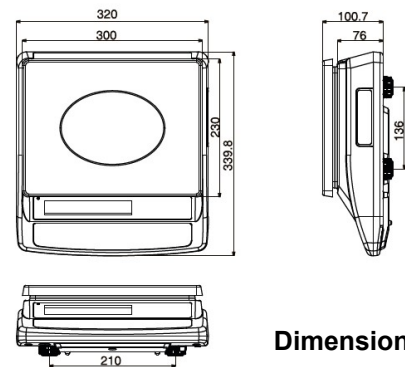

Dimension mm

SPECIFICATIONS

Art No.	AHW-30K
Item No.	01TS-D-WS001
Capacity	30kg x 1g
Max. Divisions	30'000d
Pan Size	230 x 300mm
Display	24mm LCD Display with White LED Backlight
Keyboard	7 Keys Embossed Membrane Keyboard
Operate Temp	-10 °C ~ +40°C
ADC	Sigma Delta
ADC update	≤ 1/10 Second
Housing	ABS Plastic
Power Source	AC 230V Power Cord With Rechargeable Battery (6v/4Ah)
Gross Weight	5Kg