

ELECTRONIC WEIGHING INDICATOR

FEATURES

- Easy to use front panel configuration
- Battery provide up to 90 hours continuous use
- Keyboard lock function
- Function include tare, accumulation ,check weighing, net/gross shift, counting, weighing units conversion
- Waterproof designed



OPTIONS

- RS232 interface
- Analog output (0-10V/4-20mA)
- Set point output (HI/OK/LOW/BEEP)

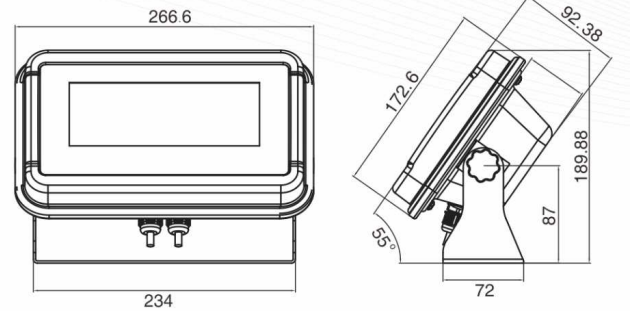

SPECIFICATIONS

Art No.	BWS
Item No.	01TS-D-W1012
Display	52mm Digit High LCD Display With White LED Backlight
Operate Temp	0°C ~ +40°C
ADC	Sigma Delta
ADC Update	≤ 1/10 Second
External Resolution	1/30,00E (O1ML/CE Type Approval)
Max. Divisions	30,000D
Keypad	7Keys
Power Source	AC230V Power Cord With Rechargeable Battery (6V/4Ah)
Load Cell Excitation Voltage	5V/150mA
Gross Weight	2.0kg
Load Cell (Max)	4x350 Ohms
Housing	Stainless Steel