

LABEL PRINTING PRICING SCALE

FEATURES

- Patented insect-proof design, which prevents the defect caused by bugs entering into the machine, ideal for the fresh and seafood dept.
- Patented hot keypad(112x2 keys) design, which can be lifted to place PLU sheet underneath. Fast to operate, easy to clean and water-proof.
- Modularized printer design for easy replacement and maintenance of paper rolls.
- Capable to choose different label formats and price unit for each PLU, flexible and free to operate.
- Able to generate batch barcode to proceed batch management for the stock and freshness, automatically set scheduling price cut with the freshness, avoiding wasting caused by factitious negligence.
- Based on POS network management concept design, exclusively offering friendly and fully featured scale software, able to carry out PLU, network, label editing and inventory management.
- Provide label graph editing software. Free format of label, adjustable label size, from 30x30mm to 60x109mm.

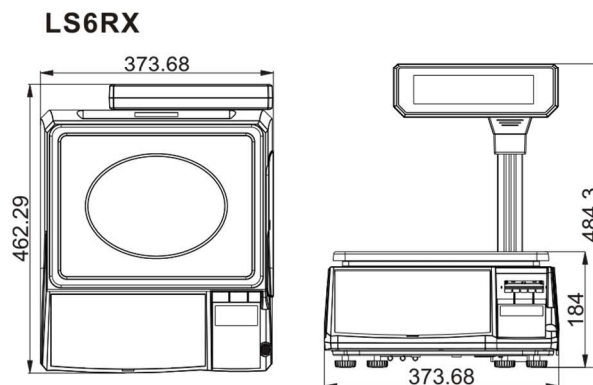

FUNCTIONS

- Adjustable font blackness based on label paper sensitivity and voltage temperature automatic compensation, makes it possible to last the service life of printer head 2 or 3 times longer than general machine.
- Able to load a paper roll with 1000pcs labels (60x40mm).
- Update program without opening case, convenience, fast and never fall behind.
- Able to print the label of different fonts, shading and commodity names.
- Support tracking & nutrition information printing.
- Easy paper loading and quick label paper replacement.
- Support wide area network, able to update data via Ethernet.
- Support account checking, avoiding the loss caused by disoperation, able to realize real time account checking for the scale data can be uploaded to PC software at all times.
- Powerful discount function, able to set different discounts according to different periods, flexible to operate.
- 90° angle rotating of the barcode printing makes it possible to be used as low cost anti-theft label. Able to prolong printer head service life and save label costs.
- Paper feed in vertical makes it possible to avoid dust and sand grain sticking on the paper rolls to damage the printer head.

LABEL PRINTING PRICING SCALE

Software Management

- Offering powerful graph editing windows software, able to print True Type graph label.
 - 1) Customers don't need to pre-print labels as stock, and also reduce the promotion resistance to customers for franchisers.
 - 2) Scanning graph, special effect of font to add the promotion.
 - 3) Transmit data and update program with the aid of telephone line, saving operating expense for customers and franchisers.
 - 4) Establish network to manage the stock, price and article number of sales office.
- Offering PLU Manager Software, able to input PLU name, article number, unit price, packing deadline etc, edit and print the PLU hotkey sheet (112X2 PLU). Easy to learn and convenient to use.
- Support parameter and password set, able to lock and manage the function key of scale to control the operation, convenient and flexible to operate.
- Offering interface technology files, able to connect with POS easily, integrated with the backstage software to realize integration and automation.
- FTP function (exclusive in the world), support GBK, UNICODE, compatible with the software of NT, Unix, and Internet.
- Font selection at will, without additional word stock IC.



PLU Management

- Able to choose independent bar code format as 18 code, EAN13, EAN8, LF Code, package type, information etc, easy to computerized management.
- Two options of PLU: With price (able to input price temporary).
- Support weight of unit set for each PLU.(g, 10g, 50g, 100g, 500g, kg, oz, LSB).
- Support quick search function.

The connection diagram of Broad Band POS Cash Register (Pinnacle exclusive)

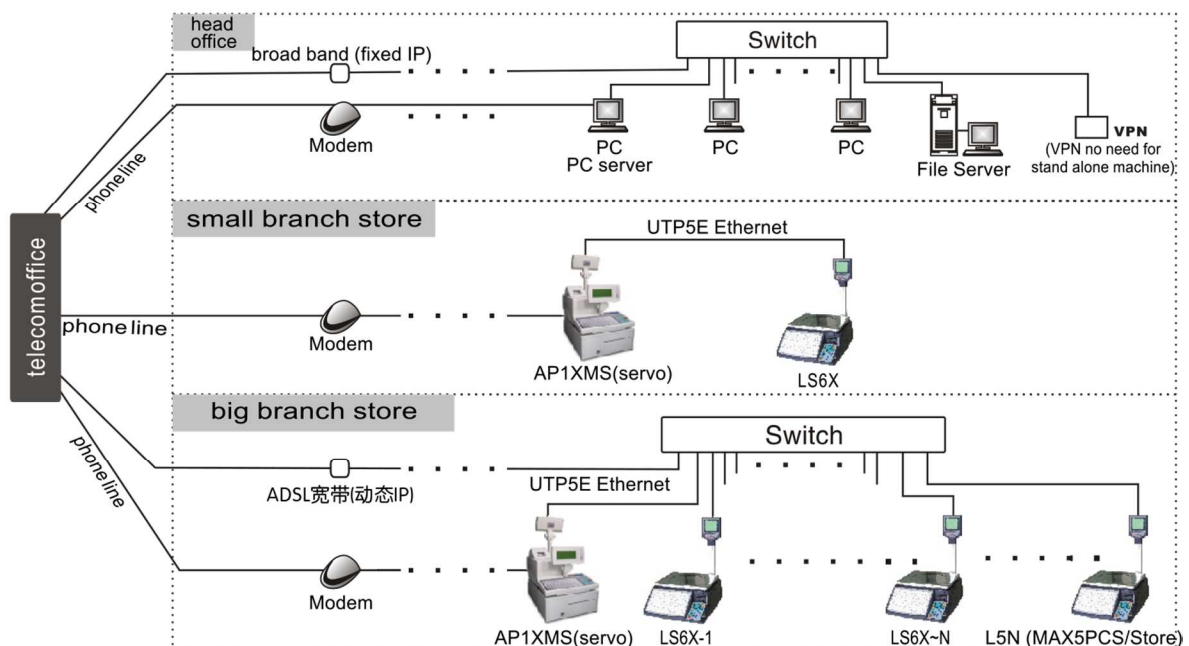

1.*除以太网外, 可作并联式RS网 (最多5台)方便临时加秤的需要.
 2.可利用电话或网络宽带构成总店分店网络即时系统.



TECHNICAL SPECIFICATIONS

Measuring Range	6kg/15kg
Verification Scale Interval	2g/5g
Display	64*384 LCD display with white backlight
Keyboard	112x2 PLU hotkeys, can be edited and downloaded by PC
Printing Speed	90mm/s
PLU Programming Data	LF code, PLU name, Article number, Unit price, Price unit, Preservation days, Tare, Barcode, Department, Package Weight, Package type (Normal, Fixed weight, Fixed price, Both fixed), message 1 & 2, Label type, Discount hotkey, Additional text
Label Format	EAN 8, EAN 13, EAN 128, Code 39, 2/5 interleaved, Code128 etc. Logo, uppercase and lowercase letters Self-configured label composing & size, adjustable label length ranging from 30mm to 109mm. Advanced label format : Various barcode, PLU name, additional information etc.
Data Storage	16M RAM, Memory 8 label types 12000 PLU, 12000 messages
Communication Interface	Ethernet, RS-232
Power Supply	AC 110V-240V, 50-60Hz
Operating Temperature	0°C-40°C
Operating Humidity	5% R.H - 85% R.H
Housing Material	ABS
Weighing Plate Material	Stainless steel
Product Size (L x W x H)	35 x 45 x 50 cm
Pan Size (L x W)	34 x 26 cm
Net Weight	6.6 Kg

SPECIFICATIONS

Art No.	LS615
Item No.	01AL-D-PC001
Capacity	15 Kg x 5 g