



# HANGING BARCODE LABEL PRINTING PRICING SCALE

LH1X15

## FEATURES

- Patent rock-relief universal joint (oil pressure) to rapidly stop swinging
- Patent adjustable nip joint for free adjustment of height
- Removable hot keypad (84x2 hot keys), workable even when soaked. The layout of hot keypad can be easily edited by the software and be printed immediately so that the cashier can operate the ECR by pressing single keys instead of memorizing and entering number combination, reducing mistakes.
- Capable of printing batch serial no. and doing batch management for stock or fresh status.
- With Ethernet network, the scale is able to obtain data from PC.
- Each PLU is allowed to have an independent code format (e.g. EAN13 code with weight, price or EAN18 code). 10,000 PLU are available.
- Able to merge perishable goods into sale, purchase and inventory management system using PLU management software, network management software, label editing software and 18 barcodes functions.
- Adjustable label size, from 30x30mm to 55x60mm
- The first label scale with logo editing software



## FUNCTIONS

- Each PLU has an individual weight unit for pricing purpose (such as gram ,100g, 500g, 600g, KG, OZ and LB), with PLU fast searching function
- Offer PLU Manager software with functions similar to Excel. Via this software, users are able to input item name, code, unit price, note, package type, expiration date, etc. Additionally, the PLU hot keypad (84x2 key) can be easily edited via the PLU manager software and printed through laser or color ink-jet printer. It is convenient, practical and easy for usage.
- Parameters and passwords of scale can be set on PC, and operations on scale can be controlled by PC.
- Offer POS port technical document, POS system is easily to be connected and can combine network s/w with back office s/w to be integrated and automatic.
- Having window s/w with a graphic editing function, which is more powerful and more flexible.
- Program can be updated without opening the cover.
- Printer can be loaded with 1000pcs labels.
- Able to select label's font.

## DIMENSIONS

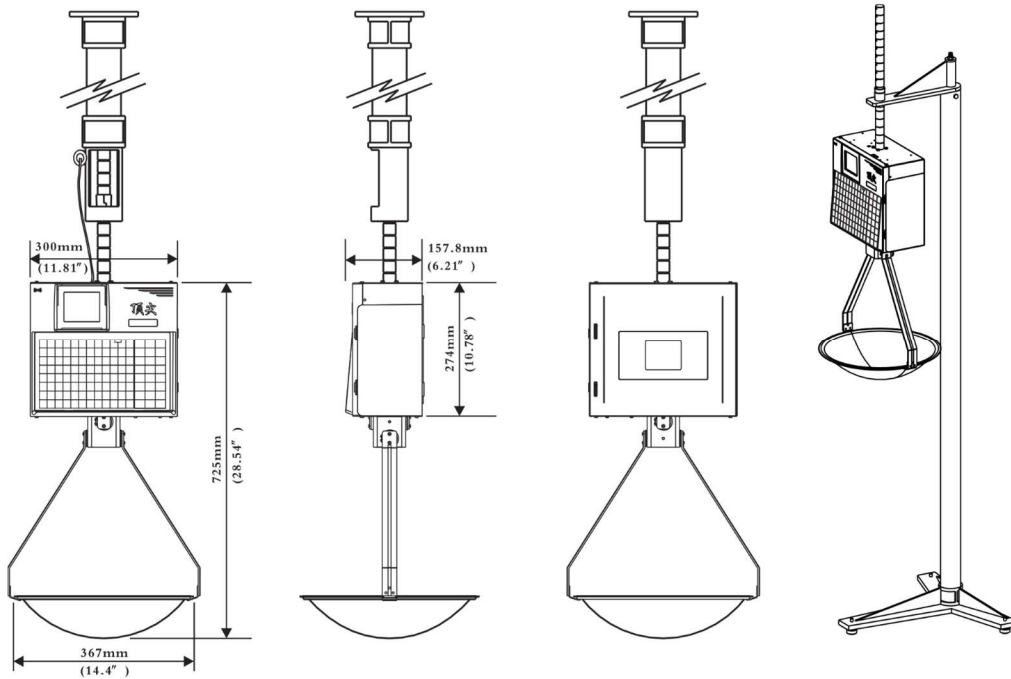

## SPECIFICATIONS

<b>Art No.</b>	LH1X15
<b>Item No.</b>	01AL-D-CR001
<b>Capacity</b>	15 Kg x 5 g
<b>Display (L x H)</b>	73 x 60 mm LCD display with white backlight
<b>PLU Memory Capacity</b>	10000 pcs in total
<b>Printing Content</b>	EAN13 barcode, commodity name, unit price, total amount, weight, alarm information, discount sign, packing date, valid date, expiration date, trade mark
<b>Power Supply</b>	AC 220V, 50/60Hz 1A
<b>Operating Temperature</b>	0°C-40°C
<b>Operating Humidity</b>	5% R.H - 93% R.H
<b>Housing Material</b>	ABS
<b>Weighing Plate Material</b>	Stainless steel
<b>Product Size (L x W x H)</b>	117 x 30 x 16 cm
<b>Pan Size (D x H)</b>	Ø33.5 cm x 8 cm
<b>Net Weight</b>	9.7 Kg