

ELECTRONIC HANGING SCALE

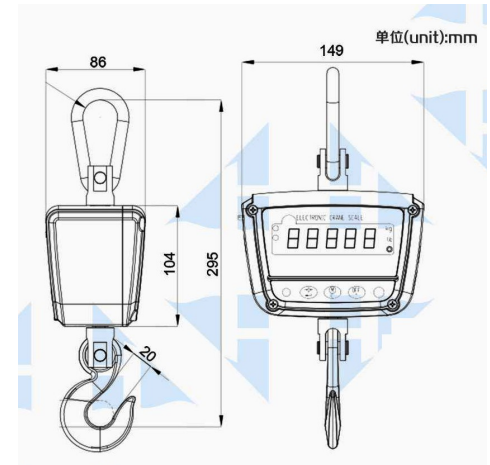

FEATURES

- Aluminum die-casting alloy housing with high strength and pleasant appearance.
- 360° safe rotated hook and shackle
- **IP65 water resistance** industrial grade to protect from extremely environment.
- Built-in long-life environmental lithium-iron battery.
- High definition FSTN display, LCD display with backlighting.
- Exclusive patent load cell, better than 1/3000 division.
- Remote control



Remote control

SPECIFICATIONS

Art No.	WCHS-GGC-300KG	
Item No.	01WC-D-CR006	
Capacity	300kg x 100g	
Display	5 Digits, 20mm LCD Display With Green Backlight	
Accuracy	III OIML R76	
Time to Stable Reading	≤ 10s	
Max. Safe Load	125% F.S.	
Limited Overload	400% F.S	
Overload Alarm	100% F.S. + 9e	
Surrounding	-20°C ~ 60°C	
Operating Temperature	-10°C ~ 40°C	
Power Source	LINH 6V Rechargeable Battery	Cable Type : Adaptor