

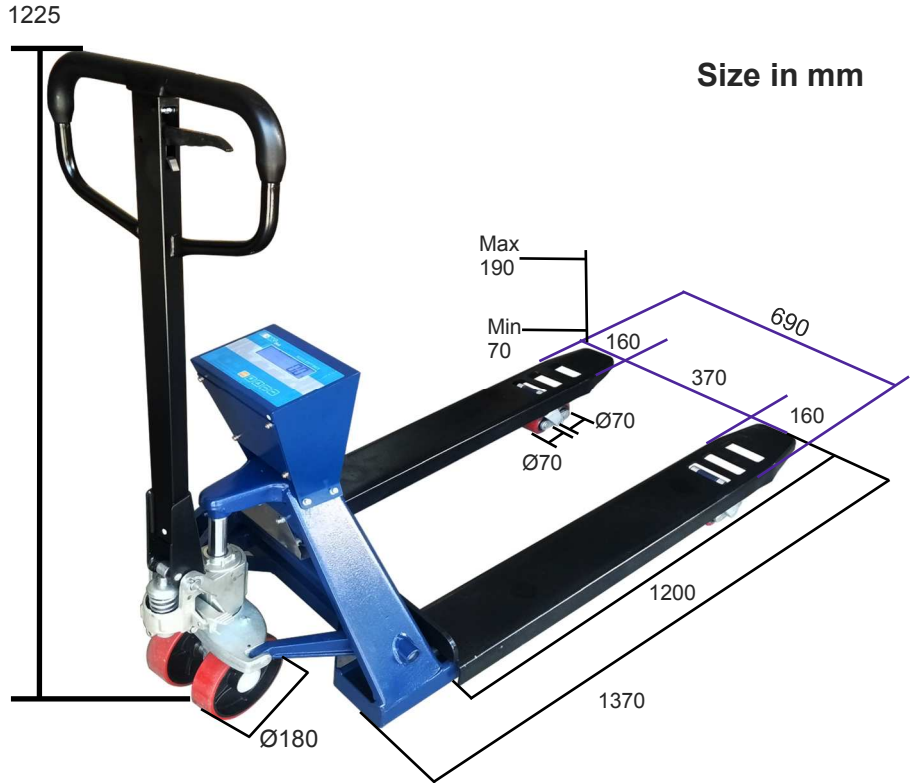

PALLET TRUCK SCALE

FEATURES

- Capacity from 1 to 2 ton
- 78mm super low scale body
- Heavy duty mould scale body
- Powder coated surface finish
- Heavy duty polyurethane wheel
- Different ways of indicator mounting
- High quality hydro-cylinder
- With quality load cell sensors
- Pallet Size: 1180x680x78mm ~ 195mm



Pallet Length	Pallet Width	Interior Size
1180mm	155mm	370mm



SPECIFICATIONS

Art No.	ESPT-B6CS
Item No.	01ES-D-PK001
Capacity	2 T x 500g
Display	6 Digits, Height 25mm, LCD Display With Blue Backlight
Keypad	5 Keys
Power Source	Adaptor DC12V/500mA , Rechargeable Battery 6V/4Ah