

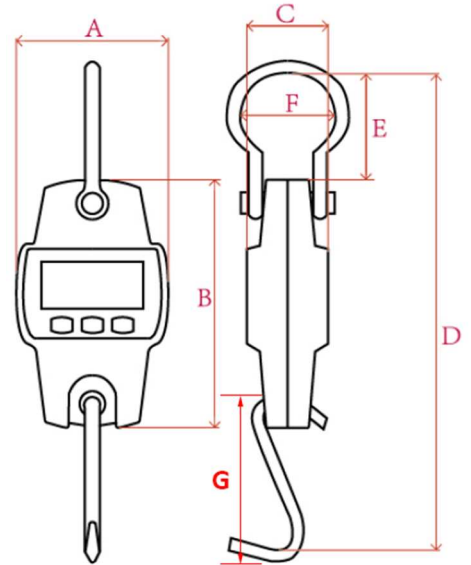

# ELECTRONIC HANGING SCALE

## FEATURES

- Precision Die-Casting Aluminum Casing
- KG/LB Selectable
- 20mm LCD
- Stainless Steel Hook
- Water Proof Keypad and Keys



Dimension Scale (mm)						
A	B	C	D	E	F	G
85	140	47	305	70	48	102

## SPECIFICATIONS

Art No.	ESHS-6122
Item No.	01ES-D-CR002
Capacity	200Kg x 100g
Display	5 Digits, Height 17mm, LCD Display With White Backlight
Power Source	Rechargeable Battery Lithium 1900mAh 3.7V Input: AC 100V ~ 240V 50/60Hz 0.25mA Output : DC 0.5V 0.5A