

AHC ELECTRONIC COUNTING SCALE

PA Cert. Number : **ATS-0064-21**

FEATURES

- Respond Quickly With Accurate Weights
- Application Programs Include : Piece Counting, Preset Tare, Piece Checking Alarm, Accumulation
- Battery Provides Up To 70 Hours Of Continuous Use (Without backlight)



OPTIONS

- RS232 Interface

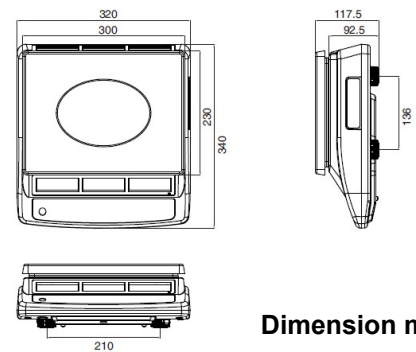

Dimension mm

SPECIFICATIONS

Art No.	AHC-6K	AHC-15K	AHC-30K
Capacity Dual Range	3kg/6kg x 1g/2g	6kg/15kg x 2g/5g	15kg/30kg x 5g/10g
Display	20mm Digit LCD Display With White LED Backlight		
Division	2 x 3000e Min 20e		
Pan Size	230 x 300mm		
Dimension (L x W x H)	340 x 320 x 117.5mm		
Keyboard	20 Keys (Membrane Keyboard)		
Operate Temp	-10 °C ~ +40°C		
Class	III		
ADC Update	≤ 1/10 Second		
Housing	ABS Plastic		
Power Source	AC Adaptor (12V/500mA), Internal Rechargeable Battery (6V/4Ah)		
Gross Weight	5Kg		