

## AHC ELECTRONIC COUNTING SCALE

### FEATURES

- Respond Quickly With Accurate Weights
- Application Programs Include : Piece Counting, Preset Tare, Piece Checking Alarm, Accumulation
- Battery Provides Up To 70 Hours Of Continuous Use (Without backlight)



### OPTIONS

- RS232 Interface

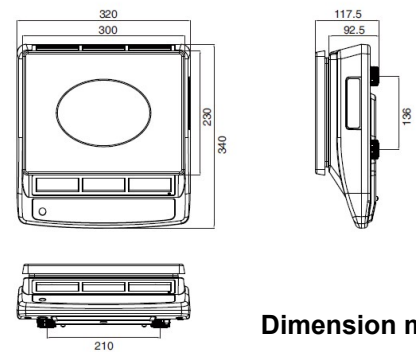

Dimension mm

### SPECIFICATIONS

Art No.	AHC-3K	AHC-6K	AHC-15K	AHC-30K
Item No.	01TS-D-WS004	01TS-D-WS005	01TS-D-WS006	01TS-D-WS007
Capacity	3 kg x 0.1 g	6 kg x 0.2 g	15 kg x 0.5 g	30 kg x 1 g
Display	20mm Digit LCD Display With White LED Backlight			
Max. Divisions	30'000d			
Pan Size	230 x 300mm			
Dimension (L x W x H)	340 x 320 x 117.5mm			
Keyboard	20 Keys (Membrane Keyboard)			
Operate Temp	-10 °C ~ +40°C			
ADC Update	≤ 1/10 Second			
Housing	ABS Plastic			
Power Source	AC Adaptor (12V/500mA), Internal Rechargeable Battery (6V/4Ah)			
Gross Weight	5Kg			