

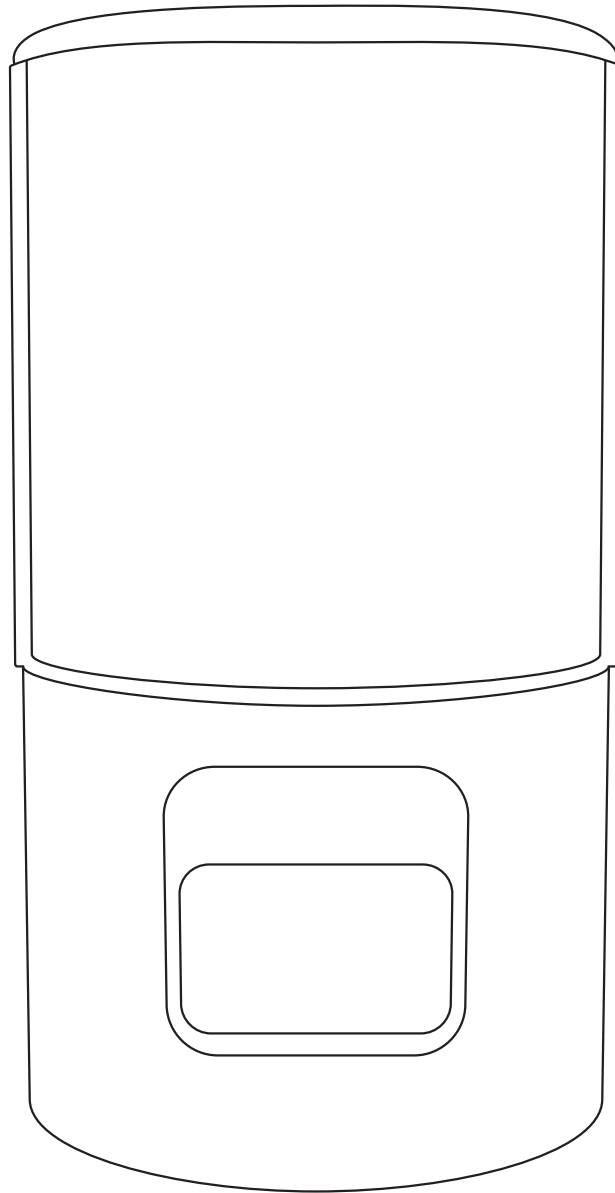

SHINING 3D

AccuFab-D1s 3D Printer



Installation Guide

Installation Procedure

STEP 1 Unpacking

- 1) Remove steel clasps on the wooden case to open it. Cut the straps and open the inner box.

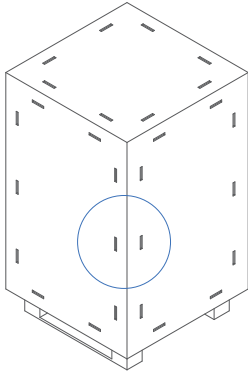

- 2) Open the cover, take out accessory box, resin tank x 2, power adaptor and power cable from fixing foam. Take out resin tanks and remove the protective films.

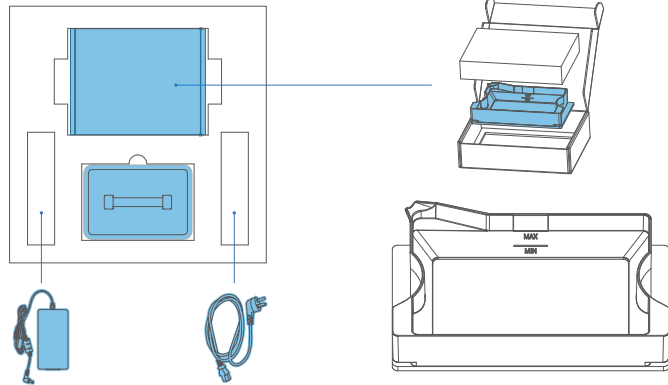

- 3) Take out the printer and remove PE bag. Open the chamber door, take out the fix foam ① & ②.

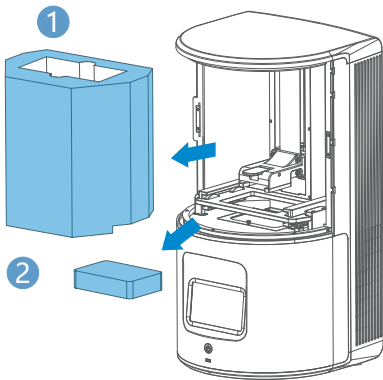

- 4) Take out build platform ③ in the fix foam ①.

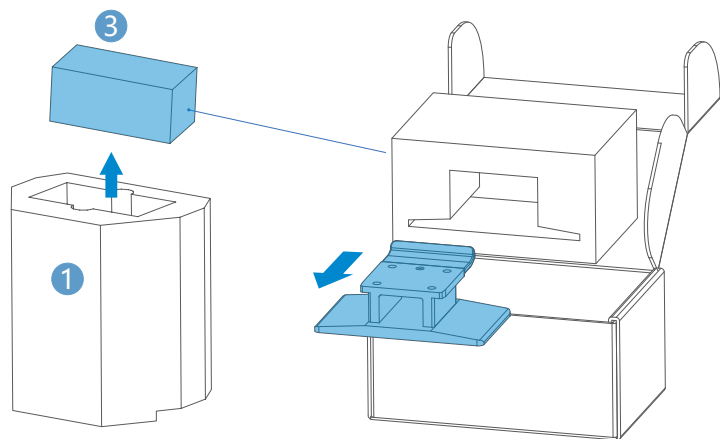

STEP 2 Boot Printer

Plug in the power adaptor and connect it with power cable. Press the power button ④ in the back, then press the power button ⑤ in the front.

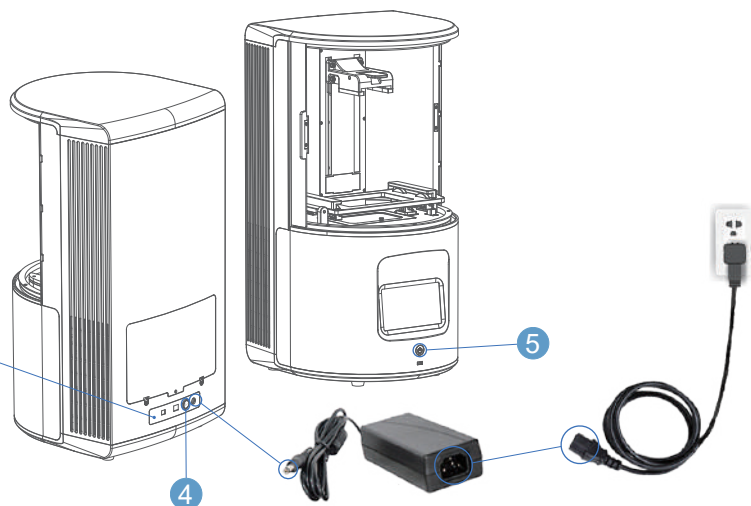
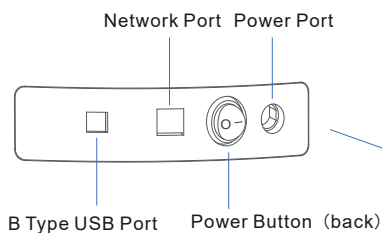

STEP 3 Install the Printer

The build platform bracket will move up automatically after booting the printer. It is time to install the resin tank and the build platform.

Install the resin tank

Remove the protective film on the protection glass. Inset the resin tank into the card slot and push it to the end in the direction indicated in the figure. When the edges of the resin tank are inside at right angles, it means the resin tank is placed appropriately.

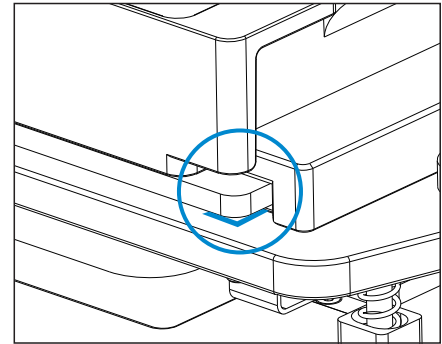
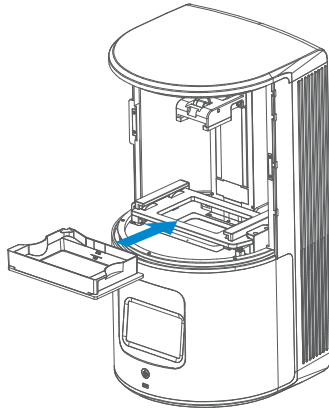

Install the build platform

Remove the protective film on the build platform. Open the handle and insert the build platform into the bracket in the direction indicated in the figure. Close the handle and lock the platform.

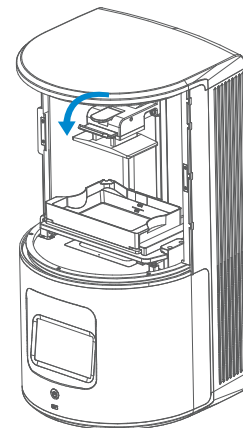
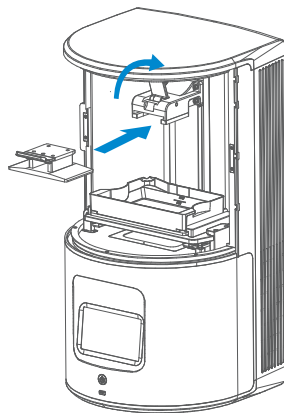

STEP 4 Add Material

Shake for 2 mins before pouring material into the resin tank to avoid sediment.

Note that the resin level should be between the indicator lines of minimum and maximum.

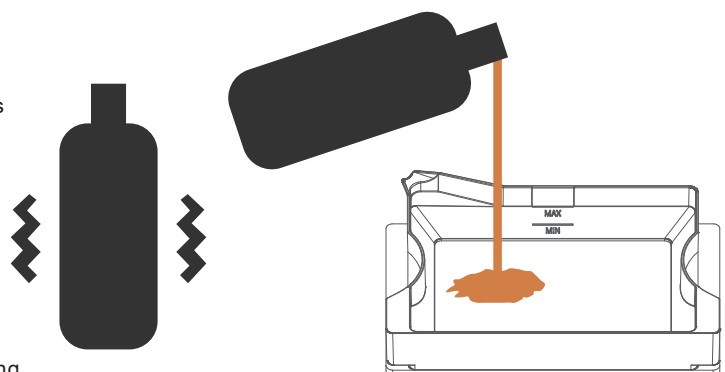

Note: You can also add resin during printing without pausing.

STEP 5 First Print

Please refer to the "AccuFab-D1s Quick Start Guide" in the flash drive. The flash drive can be used for data transmission later on.

Product Preview

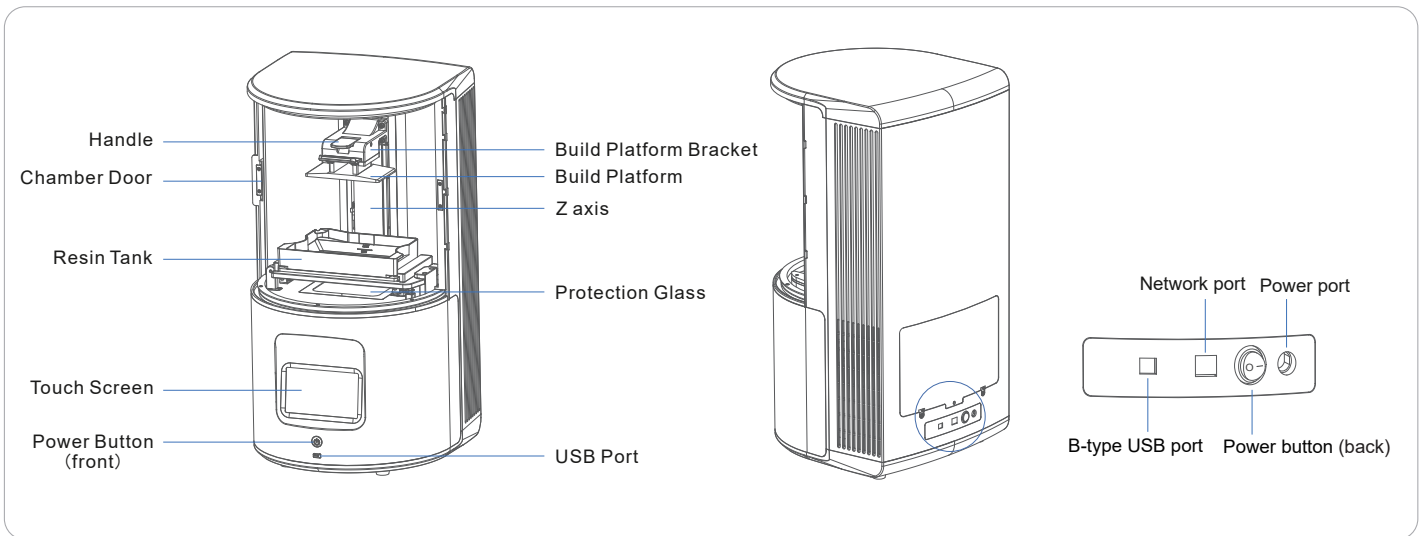

Part List

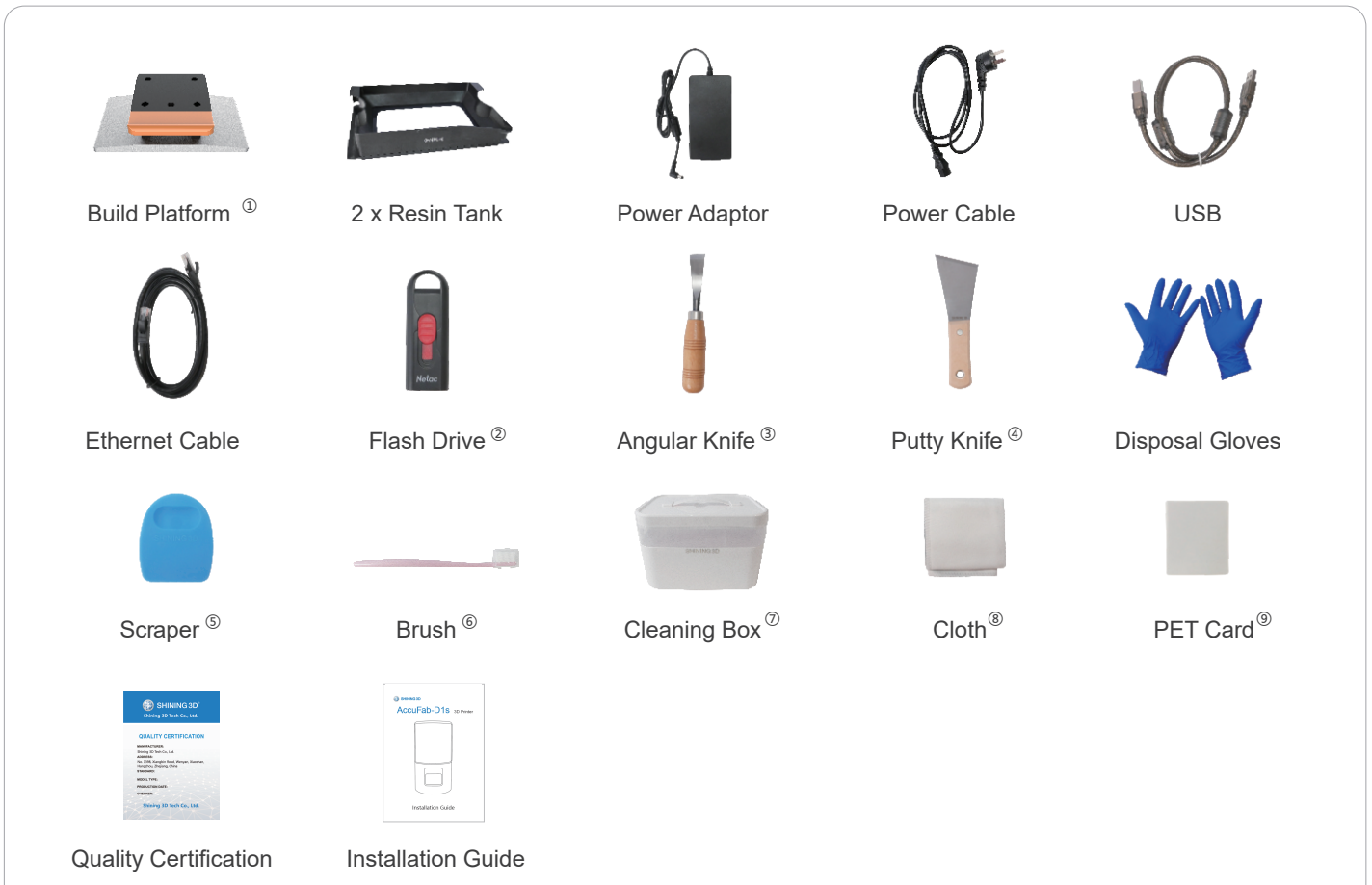

- ① **Build Platform:** Due to the test printing in the factory, the surface may have few scratches, which will not affect regular use.
- ② **Flash Drive:** Flash drive contains Installer of AccuWare, Printer profile ".sndev", User Manual, Quick Start Guide and "Factory test reports".
- ③ **Angular Knife:** Used to remove models from the platform after printing finished.
- ④ **Putty Knife:** Used to remove models from the platform after printing finished.

- ⑤ **Scraper:** Used to stir resin in the tank to avoid sediment.
- ⑥ **Brush:** Used to clean extra resin on the model.
- ⑦ **Cleaning Box:** Used to store parts or alcohol.
- ⑧ **Cloth:** Used to clean optical path including projector lens, protection glass and resin tank glass.
- ⑨ **PET Card:** Used to level the platform and remove the cured layer.



SHINING 3D

Go Digital With SHINING 3D



Document Download Center: <https://www.shining3d.com/download-center/>

Support Center: <https://support.shining3ddental.com/en/support/solution>

Aftersales service: · Create support ticket · Check ticket status

Technical resource: · FAQs · Basic Tutorials · Useful tips. · Webinars

APAC HEADQUARTERS

SHINING 3D Tech.Co.,Ltd.

P: +86-571-82999050

No.1398 Xiangbin Road, Wenyan, Xiaoshan,
Hangzhou, China, 311258

AMERICAS REGION

SHINING 3D Technology Inc.

P: +1415 259 4787

1740 César Chávez St. Unit D. San Francisco,
CA 94124, United States

EMEA REGION

SHINING 3D Technology GmbH

P: +49-711 28444089

Breitwiesenstraße 28, 70565
Stuttgart, Germany