

RM69330 Data Sheet

Single Chip Driver with 16.7M color
for 480RGBx480 OLED driver

CONFIDENTIAL

Revision : 0.0
Date : Nov,01 2017

Revision History

Version No.	Date	Description	Page	Modified By	Checked By
0.0	2017/11/01	First Release		Howard Hsiung	CN.Lin

CONFIDENTIAL

Table of Contents

Table of Contents	3
1. General Description	6
2. Features.....	7
3. Block Diagram.....	10
4. Pin Description	11
4.1 Power Supply Pins	11
4.2 Interface Pins.....	12
4.3 MIPI Interface Pins	13
4.4 Interface Logic Pins	14
4.5 Driver Output Pins (Pins for Panel)	15
4.6 DC/DC Convert Pins.....	16
4.7 Test Pins	17
5. Function Description	18
5.1 Interface Type Selection.....	18
5.2 3-wire/4-wire SPI Interface	19
5.2.1 Write Cycle and Sequence	19
5.2.2 Read Cycle and Sequence	20
5.2.3 Break and Pause Sequence	22
5.3 Display Serial Interface (DSI).....	23
5.4.1 DSI Protocol	24
5.4.2 Processor to Peripheral Transactions	26
5.4.3 Peripheral-to-Processor LP Transmission	31
5.4.4 Error Report Format	32
5.4.5 Peripheral-to-Processor Transaction – Detail Format Description	33
5.4.6 DSI Video Mode Interface Timing	34
5.4.7 Error Correction Code (ECC).....	35
5.4.8 Notice	36
5.4 Tearing Effect Output.....	37
5.5.1 Tearing Effect Line Mode.....	37
5.5.2 Tearing Effect Line Timing	39
6. Command	40
6.1 Command List.....	40
6.2 Command Description	43
NOP (0000h).....	43
SWRESET(0100h) : Software Reset	44
RDDID(0400h~0402h) : Read Display ID	45
RDNUMED(0500h) : Read Number of Errors on DSI.....	46
RDDPDM (0A00h) : Read Display Power Mode	47
RDDMADCTR (0B00h): Read Display MADCTR.....	48
RDDCOLMOD (0C00h): Read Display Pixel Format	49
RDDDIM (0D00h): Read Display Image Mode.....	51
RDDDSM (0E00h): Read Display Signal Mode	52
RDDSDR (0F00h): Read Display Self-Diagnostic Result	53
SLPIN (1000h): Sleep In	54
SLPOUT (1100h): Sleep Out.....	56
PTLON (1200h): Partial Display Mode On.....	58
NORON (1300h): Normal Display Mode On.....	59
INVOFF (2000H): Display Inversion Off	60
INVON (2100H): Display Inversion On.....	61
ALLPOFF (2200H): All Pixel Off.....	62
ALLPON (2300H): All Pixel On	64
DISPOFF (2800h): Display Off.....	66
DISPON (2900h): Display On.....	67

CASET(2A00h~2A03h) : Set Column Start Address.....	68
RASET(2B00h~2B03h) : Set Row Start Address.....	70
RAMWR (2C00h): Memory Write.....	72
PTLAR (3000h): Partial Area.....	74
PTLAR (3100h): Vertical Partial Area.....	76
TEOFF (3400h): Tearing Effect Line OFF.....	79
TEON (3500h): Tearing Effect Line ON.....	80
MADCTR (3600h): Scan Direction Control.....	83
IDMOFF (3800h): Idle Mode Off.....	85
IDMON (3900h): Enter_idle_mode.....	86
COLMOD (3A00h): Interface Pixel Format.....	88
RAMWRC (3C00h): Memory Continuous Write.....	90
STESL(4400h) : Set_Tear_Scanline.....	92
GSL (4500h) : Get_Scanline.....	93
DSTBON (4F00h): Deep Standby Mode On.....	94
WRDISBV (5100h): Write Display Brightness.....	95
RDDISBV (5200h): Read Display Brightness.....	96
WRCTRLD (5300h): Write Display Control.....	97
RDCTRLD (5400h): Read Display Control.....	98
WRRADACL (5500h): RAD_ACL Control.....	99
IMGEHCCTR (5800h) : Set_color_enhance.....	100
IMGEHCCTR (5900h) : Read_color_enhance.....	101
WRDISBV (6300h): Write HBM Display Brightness.....	102
RDDISBV (6400h): Read HBM Display Brightness.....	103
HBM_Mode (6600h) : Set_HBM_Mode.....	104
Deep_Idle_Mode (6700h) : Set_Deep Idle Mode.....	105
COLSET (7000~7F00h): Interface Pixel Format Set.....	106
COLOPT (8000h): Interface Pixel Format Option.....	110
RDDDBS(A100h) : Read_DDB_Start.....	113
RDDDBC(A800h) : Read DDB Continous.....	115
RDFCS(AA00h) : Read First Checksum.....	117
RDCCS(AF00h) : Read Continue Checksum.....	118
SetDISPMode (C200h) : set_DISP Mode.....	119
SetDSPIMode (C400h) : set_DSPI Mode.....	120
RDID1 (DA00h): ID1 Code.....	123
RDID2 (DB00h): ID2 Code.....	124
RDID3 (DC00h): ID3 Code.....	125
(FE00h): CMD Mode Switch	126
(FF00h): Read CMD Status	128
7. Electrical Characteristics.....	130
7.1 Absolute Maximum Ratings.....	130
7.2 ESD Protection Level.....	130
7.3 Latch-Up Protection Level.....	130
7.4 DC Characteristics.....	131
7.4.1 Basic Characteristics.....	131
7.4.2 Operation current.....	132
7.5 MIPI Characteristics.....	133
7.5.1 High-Speed Receiver Specification.....	133
7.5.2 Forward high speed transmissions.....	134
7.5.3 Data to Clock Timing Definitions.....	135
7.5.4 Low power transceiver specifications.....	136
7.6 AC Characteristics.....	137
7.6.1 Serial Interface Characteristics.....	137
7.6.2 DSI Timing Characteristics.....	139
7.6.3 Reset Timing.....	142
8. Power Generation.....	143
8.1 2 Supply Power (VDDI / VDD).....	143
8.2 DC/DC Converter Circuit.....	144

8.3	External Components	145
8.4	Power on/off sequence and timing	146
8.5	Power Level Modes.....	147
8.6	Maximum Series Resistance	148
9.	Pad Diagram and Coordination	149

CONFIDENTIAL

1. General Description

The RM69330 device is a single-chip solution for LTPS AMOLED that incorporates gate drivers and is capable of 480RGBx480, 400RGBx400, 360RGBx480, 320RGBx320, 320RGBx480, 272RGBx480, 240RGBx240, 240RGBx320, 180RGBx360, 180RGBx540, 128RGBx432 with internal GRAM. It includes a 2,764,800 bits internal memory, a timing controller with glass interface level-shifters and a glass power supply circuit.

The RM69330 supports MIPI Interface, 8-bit system interfaces, serial peripheral interfaces (SPI), dual serial peripheral interfaces (Dual-SPI). The specified window area can be updated selectively, so that moving pictures can be displayed simultaneously independent of the still picture area.

The RM69330 is also able to make gamma correction settings separately for RGB dots to allow benign adjustments to panel characteristics, resulting in higher display qualities. The IC possesses internal GRAM that stores 480 x 480 x 1/2 x 24 bits for 16.77M-color images. A deep standby mode is also supported for lower power consumption.

This LSI is suitable for wearable device applications, including I-watch and smart band.

CONFIDENTIAL

2. Features

- **Single chip AMOLED controller/driver with display RAM**
- **Display resolution option**
 - 480RGB x 480
 - 400RGB x 400
 - 360RGB x 480
 - 320RGB x 320
 - 320RGB x 480
 - 272RGB x 480
 - 240RGB x 240
 - 240RGB x 320
 - 180RGB x 360
 - 180RGB x 540
 - 128RGB x 432
- **Display data RAM (frame memory): 2,764,800 bits**
- **Display mode (Color mode)**
 - Full color mode: 16.7M-colors
 - Idle mode: 16.7M-colors, 4096-colors, 8-colors
- **Interface**
 - 8-bits 80-series MPU interface
 - Serial peripheral interface (SPI)
 - Dual serial peripheral interface (Dual-SPI)
 - MIPI Display Serial Interface (1 clock and 2 data lane pairs)
 - ◆ Support 1lane/2lane (1lane: 500Mbps)
 - ◆ Maximum total bit rate is 500Mbps of 2 data lanes 24-bit data format/ 360Mbps of 2 data lanes 18-bit data format/ 320Mbps of 2 data lanes 16-bit data format
- **Abundant color display and drawing functions**
 - Programmable γ -correction function for 16.7 million color display
 - Individual gamma correction setting for RGB dots
 - Partial display function
- **Sunlight readable**
- **Control power IC by one-wire interface**
- **On chip**
 - VREFP5/VREFN5 voltage generator for panel voltage
 - VGHR/VGLR voltage for gate control signal
 - Internal oscillator for display clock
 - Source output MUX 1-6 with 240ch source output pins
 - Supports gate control signals to gate driver in the panel
- **Built-in OTP function to adjust panel setting**
- **Logic / interface power supply voltage VDDI = 1.65V ~ 3.3V**
- **Analog power supply voltage VDD = 2.7V ~ 3.6V**

■ Output voltage levels

- Positive gate driver voltage range for VGHR: 3 ~ 10.5V (Max<=VGH-0.3v)
- Negative gate driver voltage range for VGLR: -2V ~ -9.5V (Min>=VGL+0.3v)
- VREFP5 panel voltage range : 0~5V (Max<=AVDD-0.3v)
- VREFN5 panel voltage range : -0.5~-4.5V (Min>=VCL+0.3v)
- Step-up 1,2 output voltage range for AVDD: 4.5 ~ 6.5V, VCL: -3.5 ~ -5.0V
- Gamma high/low voltage range for VGMP: 2.0V ~ 6.0V (Max<=AVDD-0.5v) , VGSP: 0V, 0.2125V ~ 4.5V

■ Package: COF/COG

■ Chip size evaluation : 8300um x 2060um(including scribe line)

CONFIDENTIAL

■ Power Supply Specifications

No.	Item	Description	
1	Source Driver	240 pins (480 x RGB)	
2	gate control timing Level shift	VGHR-VGLR	
5	Input Voltage	VDDI	1.65 ~ 3.3V
		VCC	Connect to VDDI or VDD(VCI)
		VDD (VDDA/VDDDB/VDDR)	2.70 ~ 3.60V
6	OLED drive voltages	AVDD	4.5V ~ 6.5V
		VGHR	3V ~ 10.5V (Max<=VGH-0.3v)
		VGLR	-2V ~ -9.5V (Min>=VGL+0.3v)
		VREFP5	0V ~ 5V (Max<=AVDD-0.3v)
		VREFN5	-0.5V ~ -4.5V (Min>=VCL+0.3v)
7	Internal step-up circuits	AVDD	VCI x2.0(dual), x3.0(single)
		VCL	VCI x -1.0(dual), x-2.0(single)
		VGH	VCI x2, x3, x4
		VGL	VCI x-2, x-3, x-4

3. Block Diagram

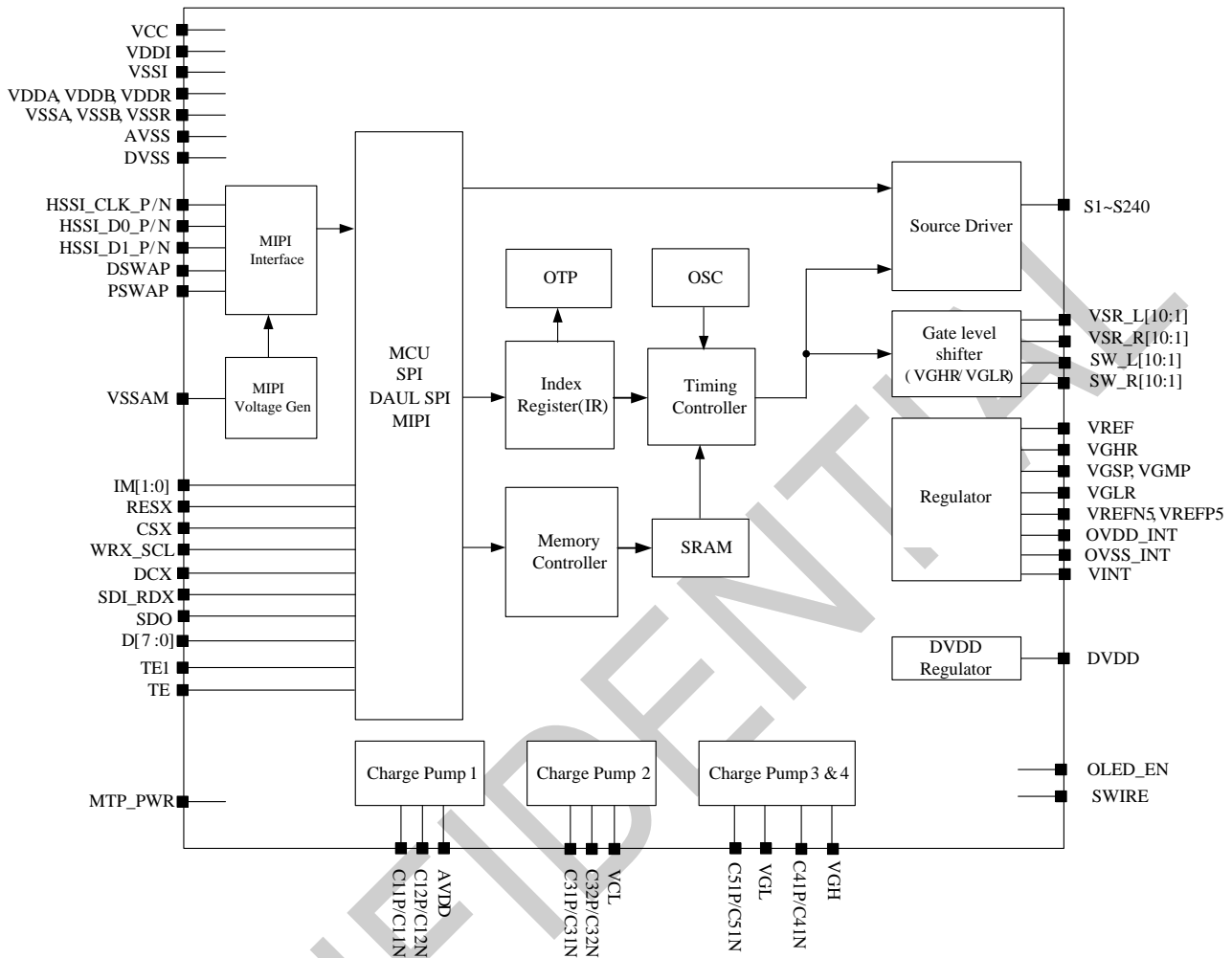

Interface

The RM69330 supports MIPI DSI interface. MIPI DSI can access both internal command and display data.

Grayscale Voltage Generating Circuit

Grayscale voltage generating circuit generates a drive voltage, which corresponds to grayscale level set in the γ correction register. The RM69330 displays 16.7M colors at the maximum.

Power Supply Circuit

The power supply circuit generates supply voltages to OLED panel, VGH, VGL.

Timing Generating

The timing controller generates timing signals for internal circuits such as the display timing.

Oscillator

The RM69330 incorporates RC oscillator circuit. The frame frequency is changeable by command settings.

Panel Driver Circuit

The OLED display driver circuit consists of 240 source drivers (S1~S240). The gate signal consists of VSR_R/L[1:10], SW_R/L[1:10] and outputs either VGHR or VGLR level.

4. Pin Description

4.1 Power Supply Pins

Signal	I/O	Function
Vddb	P	Power supply for DC/DC converter Vddb, Vdda and VDDR should be the same input voltage level
Vdda	P	Power supply for analog system. Vddb, Vdda and VDDR should be the same input voltage level
VDDR	P	Power supply for regulator system Vddb, Vdda and VDDR should be the same input voltage level
VDDI	P	Power supply for interface system except MIPI interface.
VCC	P	Power supply for DVDD regulator
VSSB	P	System ground for DC/DC converter
VSSA	P	System ground for analog system
VSSR	P	System ground for regulator system
VSSAM	P	System ground for internal MIPI analog system
VSSI	P	System ground for interface system except MIPI interface
DVSS	P	System ground for internal digital system
AVSS	P	System ground for source OP system.
MTP_PWR	P	MTP programming power supply pin (7.5V typical) Must be left open or connected to DVSS in normal condition.

4.2 Interface Pins

Signal	I/O	Function
CSX	I	Chip select input pin ("Low" enable) in 80-series MPU I/F and SPI I/F. If not used, please connect to VDDI.
WRX_SCL	I	WRX : Writes strobe signal to write data when WRX is "Low" in 80-series MPU I/F. SCL: A synchronous clock signal in SPI I/F. If not used, please connect to VSSI.
D/CX	I	Display data / command selection in 80-series MPU I/F and 4-wire SPI I/F. D/CX = "0" : Command D/CX = "1" : Display data or Parameter If not used, please connect to VSSI.
SDI_RDX	I/O	SDI: Serial input signal in SPI I/F. The data is input on the rising edge of the SCL signal. RDX : Reads strobe signal to write data when RDX is "Low" in 80-series MPU interface. If not used, please leave it Open.
SDO	O	Serial output signal in SPI I/F. The data is output on the rising/falling edge of the SCL signal. If the host places the SDI line into high-impedance state during the read interval, the SDI and SDO can be tied together. If not used, please open this pin.
D[7:0]	I/O	8-bit bi-directional data bus for 80-series MPU I/F and 8-bit input data bus for RGB I/F. These pins are not used for SPI, MIPI, please leave it Open.

CONFIDENTIAL

4.3 MIPI Interface Pins

Signal	I/O	Function																																			
HSSI_CLK_P HSSI_CLK_N	I	-These pins are DSI-CLK+/- differential clock signals if MIPI interface is used. -If not used, please connect these pins to VSSAM.																																			
HSSI_D0_P HSSI_D0_N	I/O	-These pins are DSI-D0+/- differential data signals if MIPI interface is used. -If not used, please connect these pins to VSSAM.																																			
HSSI_D1_P HSSI_D1_N	I/O	-These pins are DSI-D1+/- differential data signals if MIPI interface is used. -If not used, please connect these pins to VSSAM.																																			
DSWAP PSWAP	I	Input pin to select HSSI_D0/D1 data lane sequence and polarity in high speed interface only.																																			
		<table border="1"> <thead> <tr> <th>Pin Name</th> <th>HSSI_D0_P</th> <th>HSSI_D0_N</th> <th>HSSI_CLK_P</th> <th>HSSI_CLK_N</th> <th>HSSI_D1_P</th> <th>HSSI_D1_N</th> </tr> </thead> <tbody> <tr> <td>DSWAP=0 PSWAP=0</td> <td>DSI D0+</td> <td>DSI D0-</td> <td>DSI CLK+</td> <td>DSI CLK-</td> <td>DSI D1+</td> <td>DSI D1-</td> </tr> <tr> <td>DSWAP=0 PSWAP=1</td> <td>DSI D0-</td> <td>DSI D0+</td> <td>DSI CLK-</td> <td>DSI CLK+</td> <td>DSI D1-</td> <td>DSI D1+</td> </tr> <tr> <td>DSWAP=1 PSWAP=0</td> <td>DSI D1+</td> <td>DSI D1-</td> <td>DSI CLK+</td> <td>DSI CLK-</td> <td>DSI D0+</td> <td>DSI D0-</td> </tr> <tr> <td>DSWAP=1 PSWAP=1</td> <td>DSI D1-</td> <td>DSI D1+</td> <td>DSI CLK-</td> <td>DSI CLK+</td> <td>DSI D0-</td> <td>DSI D0+</td> </tr> </tbody> </table>	Pin Name	HSSI_D0_P	HSSI_D0_N	HSSI_CLK_P	HSSI_CLK_N	HSSI_D1_P	HSSI_D1_N	DSWAP=0 PSWAP=0	DSI D0+	DSI D0-	DSI CLK+	DSI CLK-	DSI D1+	DSI D1-	DSWAP=0 PSWAP=1	DSI D0-	DSI D0+	DSI CLK-	DSI CLK+	DSI D1-	DSI D1+	DSWAP=1 PSWAP=0	DSI D1+	DSI D1-	DSI CLK+	DSI CLK-	DSI D0+	DSI D0-	DSWAP=1 PSWAP=1	DSI D1-	DSI D1+	DSI CLK-	DSI CLK+	DSI D0-	DSI D0+
		Pin Name	HSSI_D0_P	HSSI_D0_N	HSSI_CLK_P	HSSI_CLK_N	HSSI_D1_P	HSSI_D1_N																													
		DSWAP=0 PSWAP=0	DSI D0+	DSI D0-	DSI CLK+	DSI CLK-	DSI D1+	DSI D1-																													
		DSWAP=0 PSWAP=1	DSI D0-	DSI D0+	DSI CLK-	DSI CLK+	DSI D1-	DSI D1+																													
DSWAP=1 PSWAP=0	DSI D1+	DSI D1-	DSI CLK+	DSI CLK-	DSI D0+	DSI D0-																															
DSWAP=1 PSWAP=1	DSI D1-	DSI D1+	DSI CLK-	DSI CLK+	DSI D0-	DSI D0+																															
If not used, please connect to VSSI.																																					

NOTE: "1" = VDDI level, "0" = VSSI level.

4.4 Interface Logic Pins

Signal	I/O	Function															
RESX	I	This signal will reset the device and must be applied to properly initialize the chip. Signal is active low.															
IM[1:0]	I	<p>Interface type selection. The connections of IM[1:0] which not shown in table are invalid.</p> <table border="1"> <thead> <tr> <th>IM[1:0]</th> <th>Display Data</th> <th>Command</th> </tr> </thead> <tbody> <tr> <td>00</td> <td>MIPI / 3-wire SPI</td> <td>MIPI / 3-wire SPI</td> </tr> <tr> <td>01</td> <td>MIPI / 4-wire SPI</td> <td>MIPI / 4-wire SPI</td> </tr> <tr> <td>10</td> <td>MIPI / QAD-SPI</td> <td>MIPI / QAD-SPI</td> </tr> <tr> <td>11</td> <td>MCU 8-bit</td> <td>MCU 8-bit</td> </tr> </tbody> </table>	IM[1:0]	Display Data	Command	00	MIPI / 3-wire SPI	MIPI / 3-wire SPI	01	MIPI / 4-wire SPI	MIPI / 4-wire SPI	10	MIPI / QAD-SPI	MIPI / QAD-SPI	11	MCU 8-bit	MCU 8-bit
IM[1:0]	Display Data	Command															
00	MIPI / 3-wire SPI	MIPI / 3-wire SPI															
01	MIPI / 4-wire SPI	MIPI / 4-wire SPI															
10	MIPI / QAD-SPI	MIPI / QAD-SPI															
11	MCU 8-bit	MCU 8-bit															
BSTM	I	<p>Boost mode selection pin.</p> <table border="1"> <thead> <tr> <th>BSTM</th> <th>Mode</th> </tr> </thead> <tbody> <tr> <td>0</td> <td>2 PWR(VDDI, VCI) AVDD --> internal CP VCL --> internal CP</td> </tr> <tr> <td>1</td> <td>Reserved</td> </tr> </tbody> </table>	BSTM	Mode	0	2 PWR(VDDI, VCI) AVDD --> internal CP VCL --> internal CP	1	Reserved									
BSTM	Mode																
0	2 PWR(VDDI, VCI) AVDD --> internal CP VCL --> internal CP																
1	Reserved																
TE	O	Tearing effect output pin to synchronize MCU to frame writing, activated by S/W command. When this pin is not activated, this pin is output low.															
TE1	O	If not used, please open this pin.															
SWIRE	O	Swire protocol setting pin of Power IC, If not used, please open this pin.															
OLED_EN	O	Power IC enable control pin, If not used, please open this pin.															

NOTE: "1" = VDDI level, "0" = VSSI level.

4.5 Driver Output Pins (Pins for Panel)

Signal	I/O	Function
S1 ~ S240	O	Pixel electrode driving output.
SDMY[1] ~ SDMY[21]	O	Dummy Source, leave it Open.
VSR_L[10:1] VSR_R[10:1]	O	VSR control signals, Level shift output, (VGHR-VGLR)
SW_L[10:1] SW_R[10:1]	O	VSR control signals, Level shift output, (VGHR-VGLR)

CONFIDENTIAL

4.6 DC/DC Convert Pins

Signal	I/O	Function
AVDD	O	Output voltage from step-up circuit 1, generated from VDDB. Connect a capacitor for stabilization.
VCL	O	Output voltage from step-up circuit 3, generated from VDDB. Connect a capacitor for stabilization.
VGH	O	Output voltage from step-up circuit 4. Connect a capacitor for stabilization.
VGL	O	Output voltage from step-up circuit 5. Connect a capacitor for stabilization.
C11P, C11N C12P, C12N	IO	Capacitor connection pins for the step-up circuit which generate AVDD. Connect capacitor as requirement. When not in used, please open these pins.
C31P, C31N C32P, C32N	IO	Capacitor connection pins for the step-up circuit which generate VCL. Connect capacitor as requirement.
C41P, C41N	IO	Capacitor connection pins for the step-up circuit which generate VGH. Connect capacitor as requirement.
C51P, C51N	IO	Capacitor connection pins for the step-up circuit which generate VGL. Connect capacitor as requirement.
VGHR	O	Output voltage generated from VGH. LDO output used for panel voltage. Connect a capacitor for stabilization. When not in use, please open this pin.
VGLR	O	Output voltage generated from VGL. LDO output used for panel voltage. Connect a capacitor for stabilization. When not in use, please open this pin.
VGMP	O	Output voltage generated from AVDD. LDO output for positive gamma high voltage generator.
VGSP	O	Output voltage generated from AVDD. LDO output for positive gamma low voltage generator.
VREF	O	Regulator output for internal reference voltage. Connect capacitor for stabilization.
DVDD	O	Regulator output for logic system power. Connect a capacitor for stabilization.
VREFP5	O	Regulator output for VREFP(0~5V)
VREFN5	O	Regulator output for VREFP(-0.5~-5V)
VINT	O	Connect a capacitor for stabilization.

4.7 Test Pins

Signal	I/O	Function
ANALOG_TEST 1~2	O	Test pin, not accessible to user. Must be left open.
TEST1~3	IO	Test pin, not accessible to user. Must be left open.
TESTEN	I	Test pin, not accessible to user. Must be left open., Internal pull low
EXTCLK	I	Test pin, not accessible to user. Must be left open.
DUMMY	I	Dummy PAD, leave it open

CONFIDENTIAL

5. Function Description

5.1 Interface Type Selection

Interface type selection. The connections of IM[1:0] which not shown in table are invalid.

IM[1:0]	Display Data	Command
00	MIPI / 3-wire SPI	MIPI / 3-wire SPI
01	MIPI / 4-wire SPI	MIPI / 4-wire SPI
10	MIPI / QAD-SPI	MIPI / QAD-SPI
11	MCU 8-bit	MCU 8-bit

CONFIDENTIAL

5.2 3-wire/4-wire SPI Interface

5.2.1 Write Cycle and Sequence

During a write cycle the host processor sends a single bit of data to the display module via the interface. The 3-wire/4-wire SPI interface utilizes CSX, SCL and SDA signals. SCL is driven from high to low then pulled back to high during the write cycle. The host processor provides information during the write cycle while the display module reads the host processor information on the rising edge of SCL.

During the write sequence the host processor writes one or more bytes of information to the display module via the interface. The write sequence is initiated when CSX is driven from high to low and ends when CSX is pulled high. The 3-wire serial data contains DCX bit and a transmission byte. DCX bit is driven low while command information is on the interface and is pulled high when data is present.

The 3-wire/4-wire SPI interface write command sequences are described in the following figure.

3-wire SPI

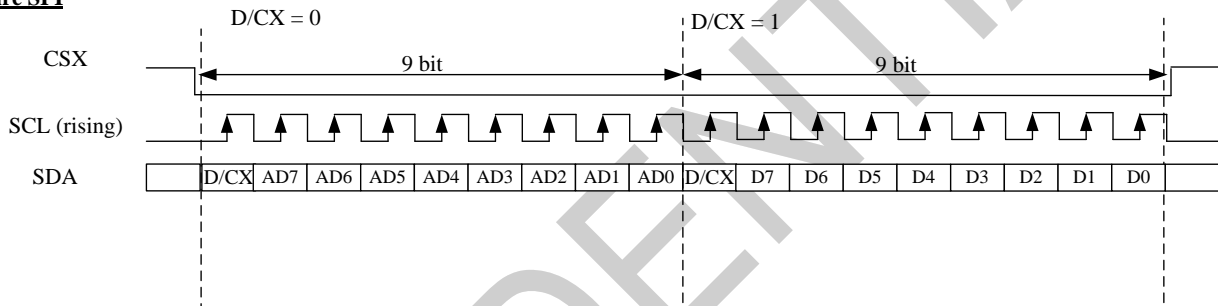

4-wire SPI

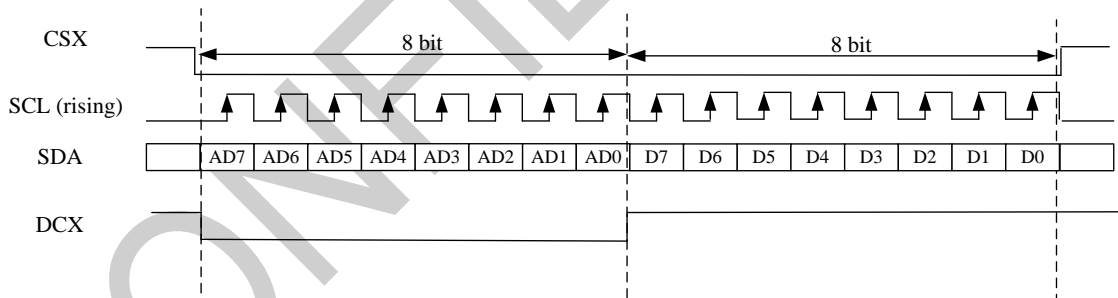

5.2.2 Read Cycle and Sequence

During a read cycle the host processor reads a single bit of data from the display module via the interface. The 3-wire/4-wire SPI interface utilizes CSX, SCL and SDA signals. SCL is driven from high to low then pulled back to high during the read cycle. The display module provides information during the read cycle while the host processor reads the display module information on the rising edge of SCL.

During the read sequence the host processor reads one or more bytes of information from the display module via the interface. The read sequence is initiated when CSX is driven from high to low and ends when CSX is pulled high. The 3-wire serial data contains DCX bit and a transmission byte. DCX is driven low while command information is on the interface and is pulled high when data is present.

The 3-wire/4-wire SPI interface read command sequences are described in the following figure.

3-wire SPI (0Ah/0B/0Ch/0Dh/0Eh/0Fh/DAh/DBh/DCh) for 8 bit read

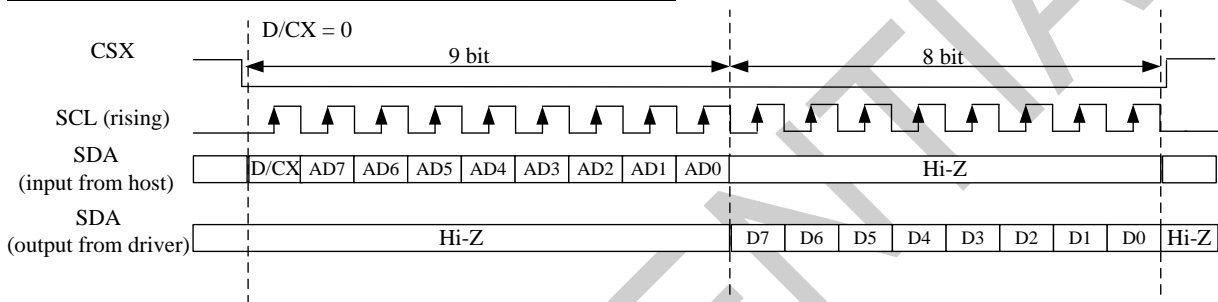

3-wire SPI (04h) for 24 bit read

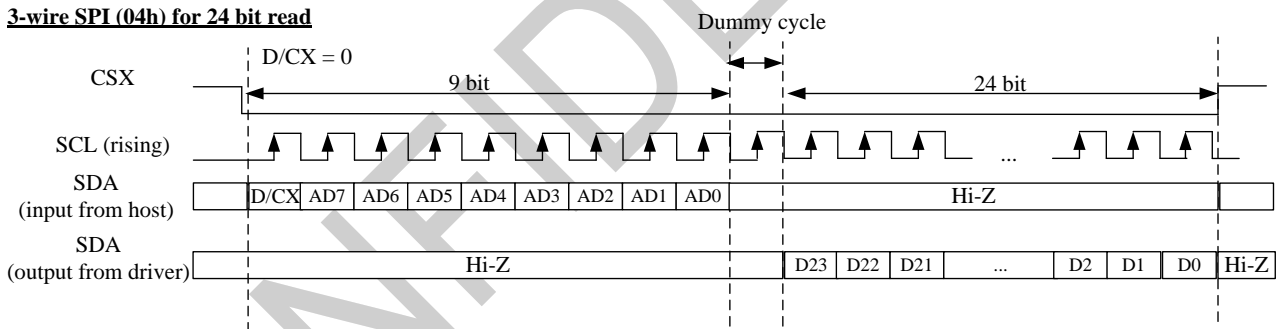

4-wire SPI (0Ah/0B/0Ch/0Dh/0Eh/0Fh/DAh/DBh/DCh) for 8 bit read

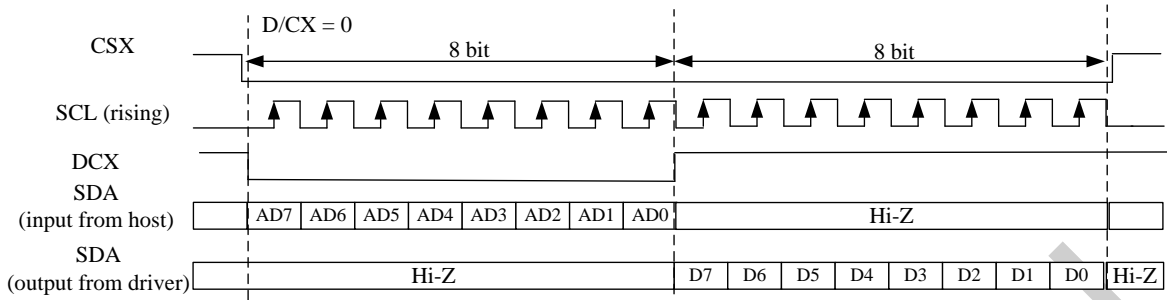

4-wire SPI (04h) for 24 bit read

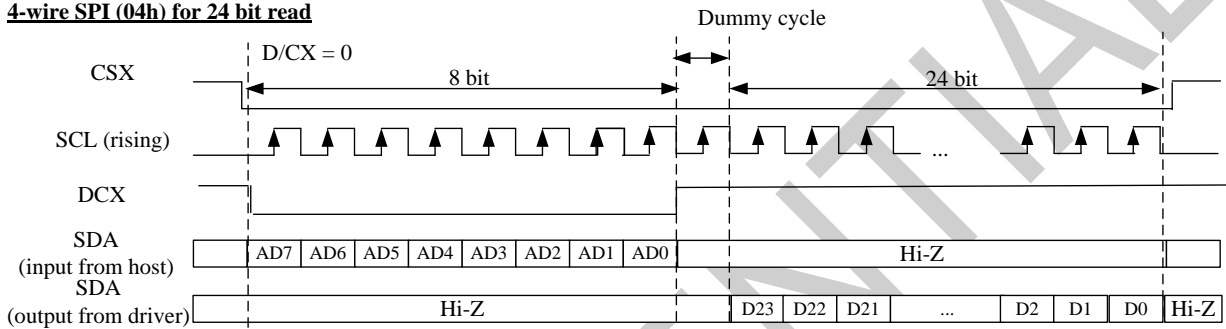

CONFIDENTIAL

5.2.3 Break and Pause Sequence

The host processor can break a read or write sequence by pulling the CSX signal high during a command or data byte. The display module shall reset its interface so it will be ready to receive the same byte when CSX is again driven low.

The host processor can pause a read or write sequence by pulling the CSX signal high between command or data bytes. The display module shall wait for the host processor to drive CSX low before continuing the read or write sequence at the point where the sequence was paused.

1. Middle of frame

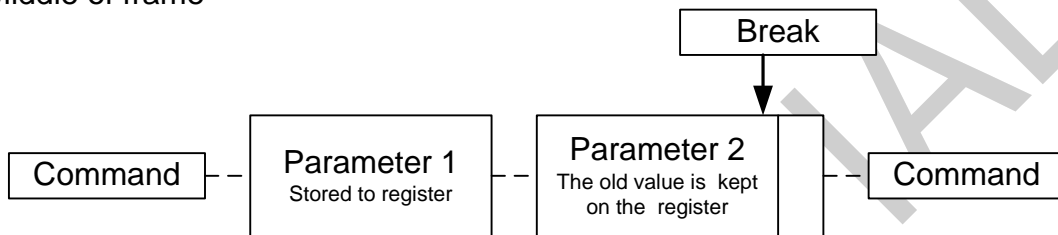

2. Between frames

Without break



With break

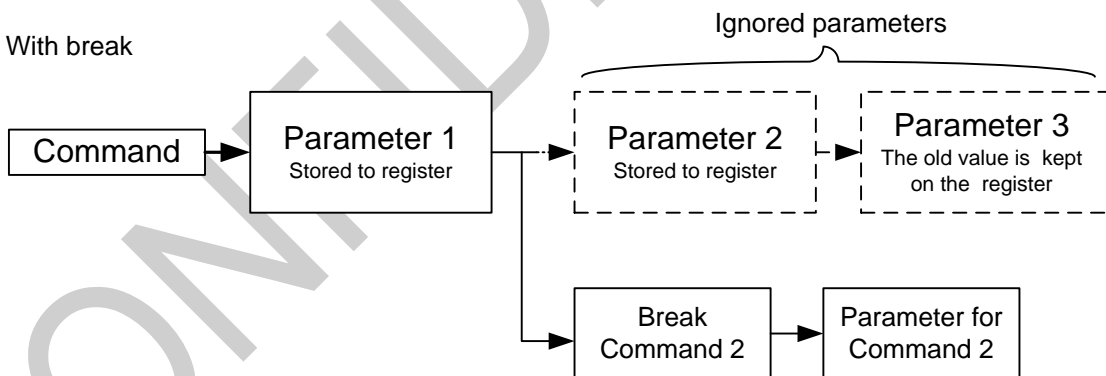

Break can be e.g. another command or noise pulse.

5.3 Display Serial Interface (DSI)

DSI-compliant peripherals support either of two basic modes of operation: Command Mode and Video Mode. The mode definitions reflect the primary intended use of DSI for display interconnect, but are not intended to restrict DSI from operating in other applications.

RM69330 is capable of both Command Mode operation and Video Mode operation. Command Mode refers to operation in which transactions primarily take the form of sending commands and data to a display module that incorporates a display controller. The display controller may include local registers and a frame buffer. Systems using Command Mode write to, and read from, the registers and frame buffer memory. The host processor indirectly controls activity at the peripheral by sending commands, parameters and data to the display controller.

The host processor can also read display module status information or the contents of the frame memory. Command Mode operation requires a bidirectional interface. Video Mode refers to operation in which transfers from the host processor to the peripheral take the form of a real-time pixel stream. In normal operation, the display module relies on the host processor to provide image data at sufficient bandwidth to avoid flicker or other visible artifacts in the displayed image. Video information should only be transmitted using High Speed Mode.

RM69330 Video Mode architectures also include a simple timing controller and partial frame buffer, used to maintain a partial-screen or lower-resolution image in standby or Low Power Mode. This permits the interface to reduce power consumption.

RM69330 Configuration:

Lane Pair	MCU(Master) RM69330(Slave)
Clock Lane	Unidirectional Lane Clock only
Data Lane 0	Bi-directional Lane Forward High-speed Bi-directional Escape Mode Bi-directional LPDT
Data Lane 1	Unidirectional Lane Forward High-Speed Escape Mode No LPDT

5.4.1 DSI Protocol

On the transmitter side of a DSI Link, parallel data, signal events, and commands are converted to packets. These packets are sent across the serial Link. The receiver side of a DSI Link performs the converse of the transmitter side, decomposing the packet into parallel data, signal events and commands.

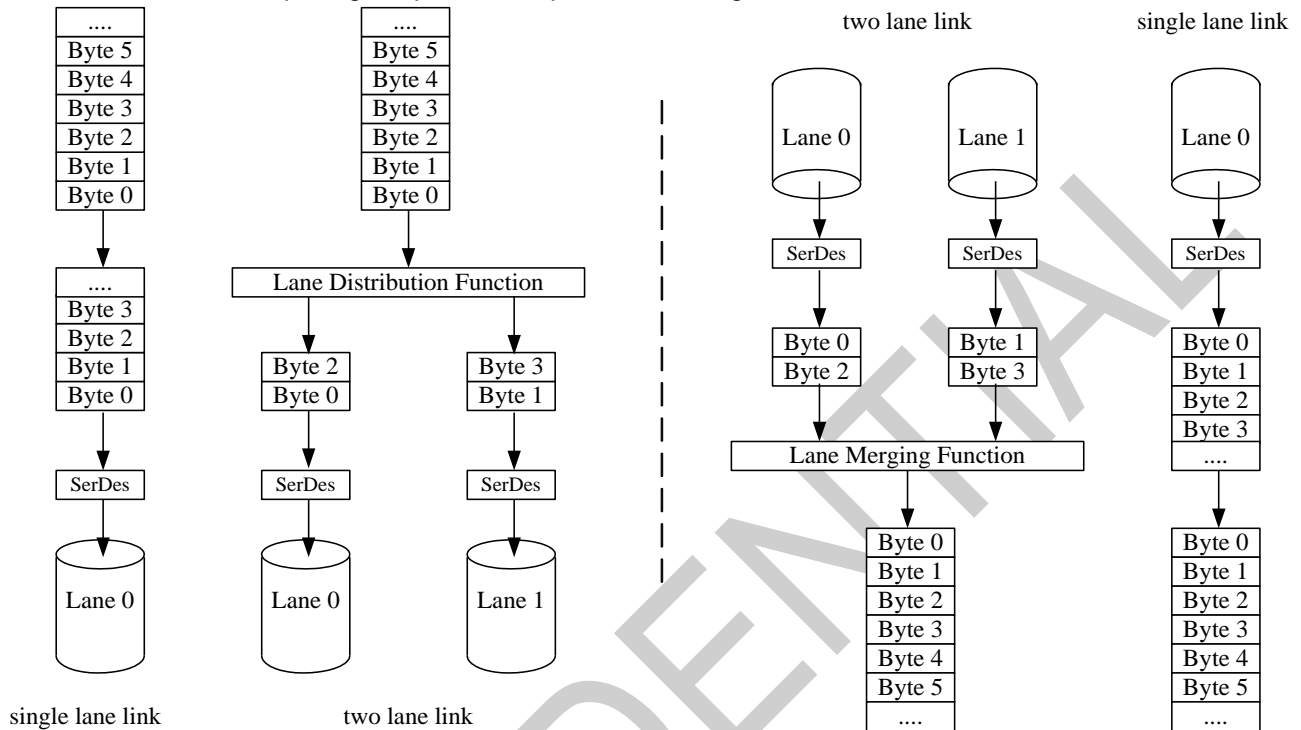

There are two kinds of packets, **short packet and long packet**.

Short packet structure:

LP-11: low power mode

SoT: start of transmission

DI: data identification

Data 0, Data1: packet data

ECC: error correction code

EoT: End of Transmission

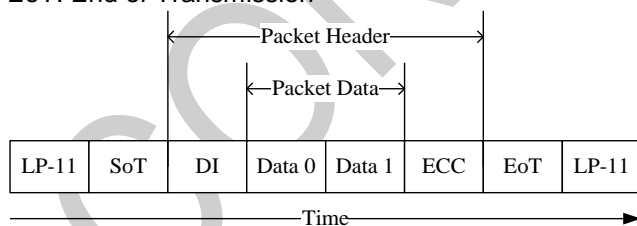

DI structure:

Virtual Channel: these two bits identify the data as directed to one of four virtual channels

Data Type: It specifies the packet structure and packet format

Virtual Channel (VC)		Data Type (DT)					
Bit 7	Bit 6	Bit 5	Bit 4	Bit 3	Bit 2	Bit 1	Bit 0

Long packet structure:

LP-11: low power mode

SoT: start of transmission

DI: data identification

Word Count: the number of data bytes of packet data

ECC: error correction code

Checksum: The 16-bit CRC generator to check packet data. If the calculated checksum of receiver are equal to the packet data, the packet data is correct. If the calculated checksum of receiver are not equal, the packet data are not correct.

EoT: end of transmission

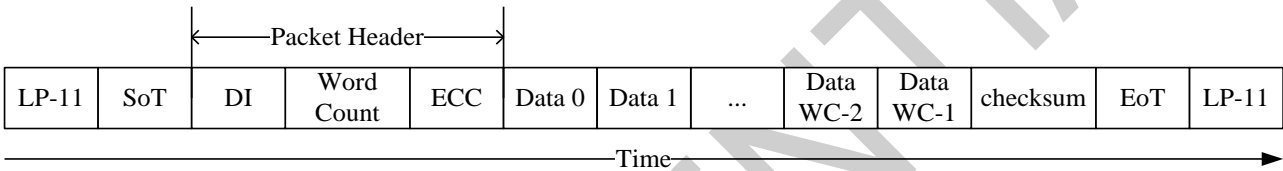

CONFIDENTIAL

5.4.2 Processor to Peripheral Transactions

Processor to Peripheral Direction Packet Data Types

Data Type	Data Type binary	Description	Packet Size
01h	00 0001	Sync Event, V Sync Start	Short
11h	01 0001	Sync Event, V Sync End	Short
21h	10 0001	Sync Event, H Sync Start	Short
31h	11 0001	Sync Event, H Sync End	Short
08h	00 1000	End of Transmission packet (EoTp)	Short
02h	00 0010	Color Mode (CM) Off Command	Short
12h	01 0010	Color Mode (CM) On Command	Short
22h	10 0010	reserved	Short
32h	11 0010	reserved	Short
03h	00 0011	reserved	Short
13h	01 0011	Generic Short WRITE, 1 parameter	Short
23h	10 0011	Generic Short WRITE, 2 parameters	Short
04h	00 0100	reserved	Short
14h	01 0100	Generic READ, 1 parameter	Short
24h	10 0100	Generic READ, 2 parameters	Short
05h	00 0101	DCS Short WRITE, no parameters	Short
15h	01 0101	DCS Short WRITE, 1 parameter	Short
06h	00 0110	DCS READ, no parameters	Short
37h	11 0111	Set Maximum Return Packet Size	Short
09h	00 1001	Null Packet, no data	Long
19h	01 1001	Blanking Packet, no data	Long
29h	10 1001	Generic Long Write	Long
39h	11 1001	DCS Long Write/write_LUT Command Packet	Long
0Eh	00 1110	Packed Pixel Stream, 16-bit RGB, 5-6-5 Format	Long
1Eh	01 1110	Packed Pixel Stream, 18-bit RGB, 6-6-6 Format	Long
2Eh	10 1110	Loosely Packed Pixel Stream, 18-bit RGB, 6-6-6 Format	Long
3Eh	11 1110	Packed Pixel Stream, 24-bit RGB, 8-8-8 Format	Long

Sync Event, Data Type = xx 0001

Sync Events are all short packets and time-accurately. They can perform like the start and end of sync pulses. To represent timing information as accurately as possible, a V Sync Start event represents the start of the VSA and also implies an H Sync Start event for the first line of the VSA. Hence, a V Sync End event implies an H Sync Start event for the last line of the VSA. Sync events may be concatenated with blanking packets to convey inter-line timing accurately and avoid the overhead of switching between LPS and HS for every event. Note there is a power penalty for keeping the data line in HS mode.

EoT packet

This short packet is used to indicate the end of a high speed (HS) transmission. This packet will enhance overall system reliability. Although the main objective of the EoTp is to enhance robustness during HS transmission mode, RM69330 can detect and interpret arriving EoTps regardless of transmission mode (HS or LP modes)

Color Mode Off / On Command

They are short packet commands to switch video display module between normal display mode and low-color mode for power saving.

Generic short write / read packet

Generic Short WRITE command is a Short packet type for sending generic data to the peripheral. Generic READ request is a Short packet requesting data from the peripheral.

DCS commands

DCS short write command

DCS short write command is used to write a single data byte command to display module. If there is a valid parameter byte, data type bit 4 shall be set to 1. If there is no valid parameter byte, data type bit 4 shall be set to 0 and the parameter byte shall be 00h.

DCS read commands

The commands are used to request data from s display module.

DCS Long Write / write_LUT command

The commands are used to send larger blocks of data to a display module.

Maximum return packet size

This command specifies the maximum size of the payload in a long packet transmission from a display module to host processor.

Null Packet

This is a mechanism for keeping the data lane(s) in high speed mode while sending dummy data.

Blanking Packet

A Blanking packet is used to convey blanking timing information in a Long packet. The packet represents a period between active scan lines of a Video Mode display, where traditional display timing is provided from the host processor to the display module. The blanking period may have Sync Event packets interspersed between blanking segments. Blanking packets may contain arbitrary data as payload.

Generic Long Write

This is used to transmit arbitrary blocks of data from a host processor to a peripheral.

Packed Pixel Stream, 16-bit Format, Data Type: 00 1110

The pixel format is five bits red, six bits green and five bits blue. The green component is split across two bytes. Within a color component, the LSB is sent first, the MSB last.

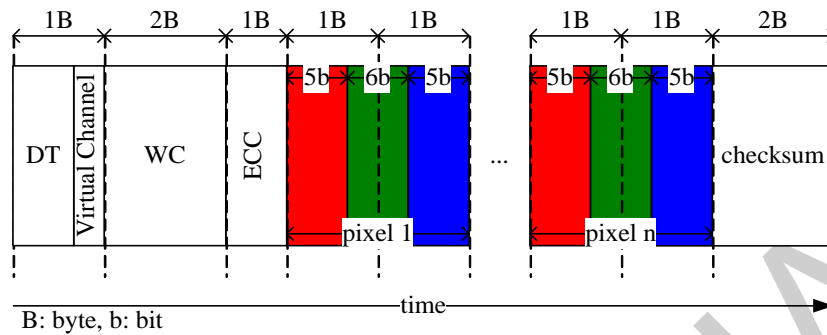

CONFIDENTIAL

Packet pixel stream, 18-bit format, Data Type: 01 1110

The pixel format is six bits red, six bits green and six bits blue. Within a color component, the LSB is sent first, the MSB last.

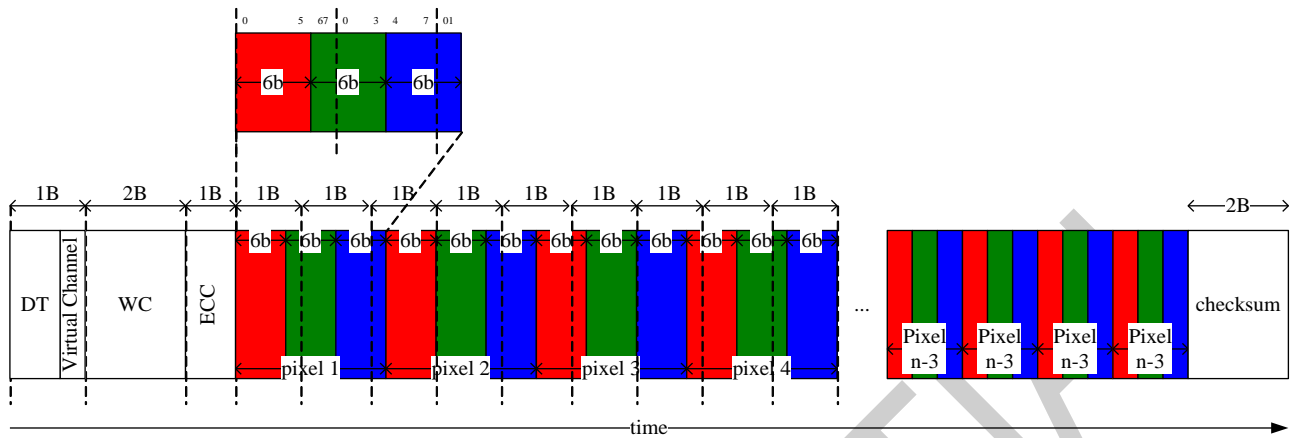

Packet pixel stream, 18-bit format in three bytes, Data Type: 10 1110

This is 18-bit pixel lossely packed format, each R, G or B color component is six bits but shifted to the upper bits of byte.

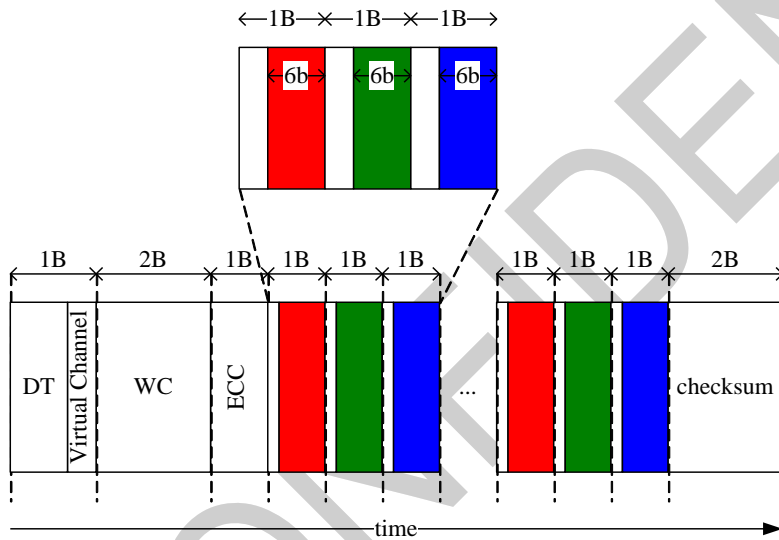

Packet pixel stream, 24-bit format, Data Type: 11 1110
The pixel format is eight bits red, eight bits green and eight bits blue.

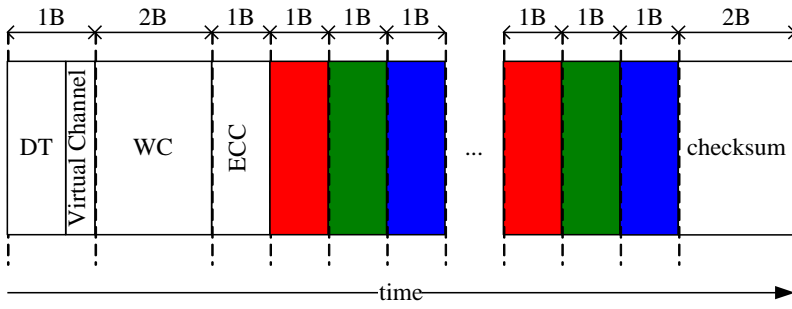

CONFIDENTIAL

5.4.3 Peripheral-to-Processor LP Transmission

All Command Mode systems require bidirectional capability for returning READ data, acknowledge, or error information to the host processor. Multi-Lane systems shall use Lane 0 for all peripheral-to-processor transmissions. Reverse-direction signaling shall only use low power mode transmission.

Packet structure for peripheral-to-processor transaction is the same as for the processor-to-peripheral direction. For the processor-to-peripheral direction, two basic packet formats are the same as the peripheral-to-processor direction: Short and Long packet structure. BTA shall take place after every peripheral-to-processor transaction. This returns bus control to the host processor following the completion of the LP transmission from the peripheral.

There are four basic types of peripheral-to-processor transactions.

Tearing Effect: It is a Trigger message sent to convey display timing information to the host processor.

Acknowledge: It is a Trigger Message sent when the current transmission, as well as all preceding transmissions since the last peripheral to host communication.

Acknowledge and Error Report: It is a Short packet sent if any errors were detected in preceding transmissions from the host processor.

Response to Read Request: It may be a Short or Long packet that returns data requested by the preceding READ command from the processor.

Interpretation of processor-to-peripheral transactions with BTA asserted, and the expected responses, are as follows:

Following a non-Read command: If no errors were detected, the peripheral shall respond with Acknowledge.

Following a Read request: The peripheral shall send the requested READ data if no errors were detected and stored since the last peripheral to host communication.

Following a Read request: If only a single-bit ECC error was detected and corrected, the peripheral shall send the requested READ data in a Long or Short packet and a 4-byte Acknowledge and Error Report packet in the same LP transmission.

Following a non-Read command: If only a single-bit ECC error was detected and corrected, the peripheral shall respond to BTA by sending a 4-byte Acknowledge and Error Report packet.

Following a Read request: If multi-bit ECC errors were detected and not corrected, the peripheral shall send a 4-byte Acknowledge and Error Report packet without sending Read data.

Following a non-Read command: If multi-bit ECC errors were detected and not corrected, the peripheral shall not execute the command, and shall send a 4-byte Acknowledge and Error Report packet.

Following any command: If SoT Error, SoT Sync Error, the VC of DSI or the ID of DSI Invalid or DSI protocol violation was detected, or the DSI command was not recognized, the peripheral shall send a 4-byte Acknowledge and Error Report response.

Following any command: If EoT Sync Error or LP Transmit Sync Error is detected, or a checksum error is detected in the payload, the peripheral shall send a 4-byte Acknowledge and Error Report packet.

5.4.4 Error Report Format

The following table shows the bit assignment for all error report.

Bit	Description
0	SoT Error
1	SoT Sync Error
2	EoT Sync Error
3	Escape Mode Entry Command Error
4	Low-Power Transmit Sync Error
5	HS Receive Timeout Error
6	False Control Error
7	Reserved
8	ECC Error, single-bit (detected and corrected)
9	ECC Error, multi-bit (detected, not corrected)
10	Checksum Error (Long packet only)
11	DSI Data Type Not Recognized
12	DSI VC ID Invalid
13	reserved
14	reserved
15	reserved

5.4.5 Peripheral-to-Processor Transaction – Detail Format Description

The following list is the complete set of peripheral-to-processor data types.

Data type, hex	Data type binary	Description	Packet size
02h	00 0010	Acknowledge and error report	short
08h	00 1000	reserved	short
11h	01 0001	GEN short read reponse, 1byte returned	short
12h	01 0010	GEN short read reponse, 2bytes returned	short
1Ah	01 1010	Generic long read reponse	long
1Ch	01 1100	DCS long read reponse	long
21h	10 0001	DCS short read reponse, 1byte returned	short
22h	10 0010	DCS short read reponse, 2bytes returned	short

Acknowledge and error report: It is sent with BTA asserted when a reportable error is detected in the preceding, or earlier, transmission from the host processor.

Generic Short Read Response: This is the short-packet response to Generic READ Request. Packet composition is the Data Identifier (DI) byte, two bytes of payload data and an ECC byte. If the command itself is possibly corrupt, due to an uncorrectable ECC error, SoT or SoT Sync error, the requested READ data packet shall not be sent and only the Acknowledge and Error Report packet shall be sent.

Generic long read reponse: This is the long-packet response to Generic READ Request. Packet composition is DI followed by a two-byte Word Count, an ECC byte, N bytes of payload, and a two-byte Checksum. If the command itself is possibly corrupt, due to an uncorrectable ECC error, SoT or SoT Sync error, the requested READ data packet shall not be sent and only the Acknowledge and Error Report packet shall be sent.

DCS long read reponse: This is a Long packet response to DCS Read Request. Packet composition is DI followed by a two-byte Word Count, an ECC byte, N bytes of payload, and a two-byte Checksum. If the DCS command itself is possibly corrupt, due to uncorrectable ECC error, SoT or SoT Sync error, the requested READ data packet shall not be sent and only the Acknowledge and Error Report packet shall be sent.

DCS short read reponse: This is the short-packet response to DCS Read Request. Packet composition is DI, two bytes of payload data and an ECC byte. If the command itself is possibly corrupt, due to an uncorrectable ECC error, SoT or SoT Sync error, the requested READ data packet shall not be sent and only the Acknowledge and Error Report packet shall be sent.

5.4.6 DSI Video Mode Interface Timing

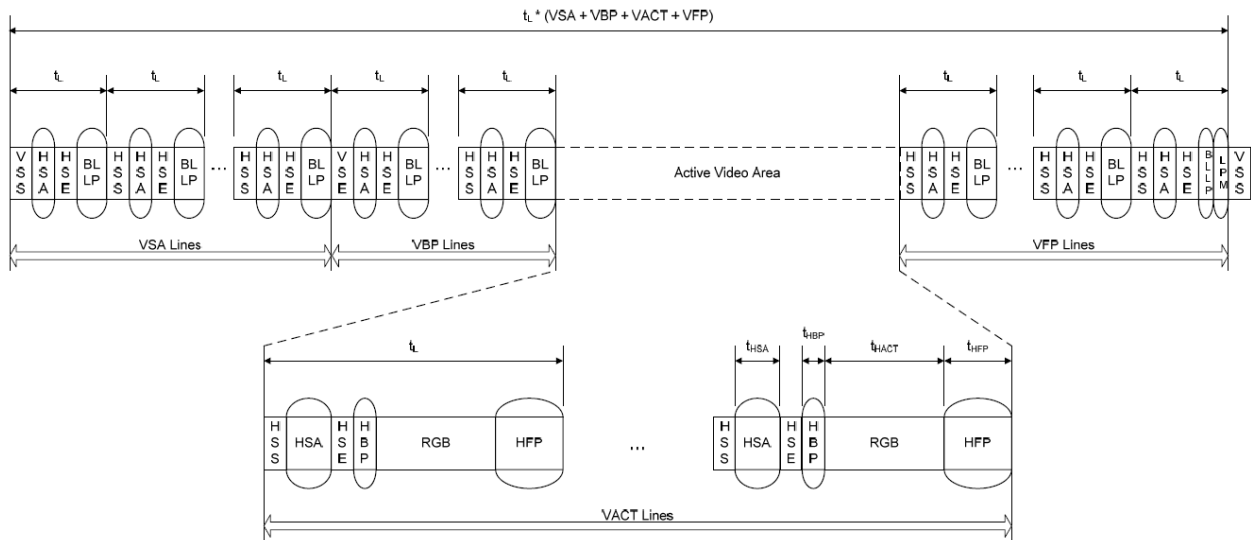

CONFIDENTIAL

5.4.7 Error Correction Code (ECC)

ECC shall always be generated and appended in the Packet Header from the host processor. Peripherals with Bidirectional Links shall also generate and send ECC.

The number of parity or error check bits required is given by the Hamming rule, which uses parity to correct a single-bit error or detect a two-bit error, but are not capable of doing both simultaneously. DSI uses Hamming-modified codes where an extra parity bit is used to support both single error correction as well as two-bit error detection.

Since Packet Headers are fixed at four bytes (twenty-four data bits and eight ECC bits), P6 and P7 of the ECC byte are unused and shall be set to zero by the transmitter. The receiver shall ignore P6 and P7 and set both bits to zero before processing ECC.

The parity bits of ECC are defined as below:

$$P7 = 0$$

$$P6 = 0$$

$$P5 = D10 \wedge D11 \wedge D12 \wedge D13 \wedge D14 \wedge D15 \wedge D16 \wedge D17 \wedge D18 \wedge D19 \wedge D21 \wedge D22 \wedge D23$$

$$P4 = D4 \wedge D5 \wedge D6 \wedge D7 \wedge D8 \wedge D9 \wedge D16 \wedge D17 \wedge D18 \wedge D19 \wedge D20 \wedge D22 \wedge D23$$

$$P3 = D1 \wedge D2 \wedge D3 \wedge D7 \wedge D8 \wedge D9 \wedge D13 \wedge D14 \wedge D15 \wedge D19 \wedge D20 \wedge D21 \wedge D23$$

$$P2 = D0 \wedge D2 \wedge D3 \wedge D5 \wedge D6 \wedge D9 \wedge D11 \wedge D12 \wedge D15 \wedge D18 \wedge D20 \wedge D21 \wedge D22$$

$$P1 = D0 \wedge D1 \wedge D3 \wedge D4 \wedge D6 \wedge D8 \wedge D10 \wedge D12 \wedge D14 \wedge D17 \wedge D20 \wedge D21 \wedge D22 \wedge D23$$

$$P0 = D0 \wedge D1 \wedge D2 \wedge D4 \wedge D5 \wedge D7 \wedge D10 \wedge D11 \wedge D13 \wedge D16 \wedge D20 \wedge D21 \wedge D22 \wedge D23$$

The table below shows a compact way to specify the encoding of parity and decoding of syndromes.

ECC Parity Generation Rules:

Data Bit	P7	P6	P5	P4	P3	P2	P1	P0	Hex
0	0	0	0	0	0	1	1	1	0x07
1	0	0	0	0	1	0	1	1	0x0B
2	0	0	0	0	1	1	0	1	0x0D
3	0	0	0	0	1	1	1	0	0x0E
4	0	0	0	1	0	0	1	1	0x13
5	0	0	0	1	0	1	0	1	0x15
6	0	0	0	1	0	1	1	0	0x16
7	0	0	0	1	1	0	0	1	0x19
8	0	0	0	1	1	0	1	0	0x1A
9	0	0	0	1	1	1	0	0	0x1C
10	0	0	1	0	0	0	1	1	0x23
11	0	0	1	0	0	1	0	1	0x25
12	0	0	1	0	0	1	1	0	0x26
13	0	0	1	0	1	0	0	1	0x29
14	0	0	1	0	1	0	1	0	0x2A
15	0	0	1	0	1	1	0	0	0x2C
16	0	0	1	1	0	0	0	1	0x31
17	0	0	1	1	0	0	1	0	0x32
18	0	0	1	1	0	1	0	0	0x34
19	0	0	1	1	1	0	0	0	0x38
20	0	0	0	1	1	1	1	1	0x1F
21	0	0	1	0	1	1	1	1	0x2F
22	0	0	1	1	0	1	1	1	0x37
23	0	0	1	1	1	0	1	1	0x3B

5.4.8 Notice

1. We recommend users to stay in STOP state for 500ns when switching from LPDT to HSDT.
2. We recommend users to adopt EoTp to enhance overall robustness of the system during HSDT.

CONFIDENTIAL

5.4 Tearing Effect Output

The tearing effect output line supplies to the HOST a panel synchronization signal. This signal can be enabled or disabled by the `set_tear_off` (34h) and `set_tear_on` (35h) commands. The mode of the tearing effect signal is defined by the parameter of the `set_tear_on` (35h) and `set_tear_scanline`(44h) commands. The signal can be used by the HOST to synchronize internal VSYNC when displaying video images.

5.5.1 Tearing Effect Line Mode

Mode 1, the tearing effect output signal consist of V-sync information only:

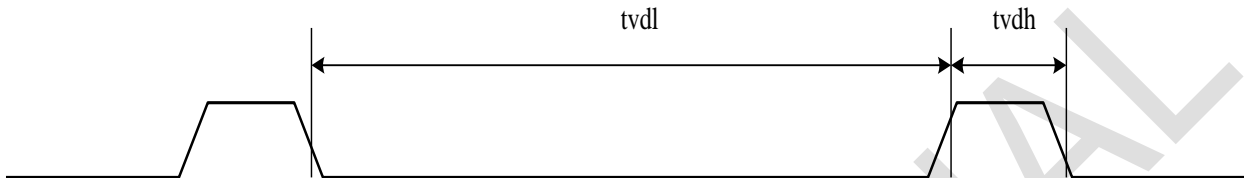

$tvdh$ = The LCD display is not updated from the frame memory.
 $tvdl$ = The LCD display is updated from the frame memory.

Mode 2, the tearing effect output signal consist of V-sync and H-sync information:



$thdh$ = The LCD display is not updated from the frame memory.
 $thdl$ = The LCD display is updated from the frame memory.

Mode 3, this mode turn on the tearing effect output signal when vertical scanning reaches line N.

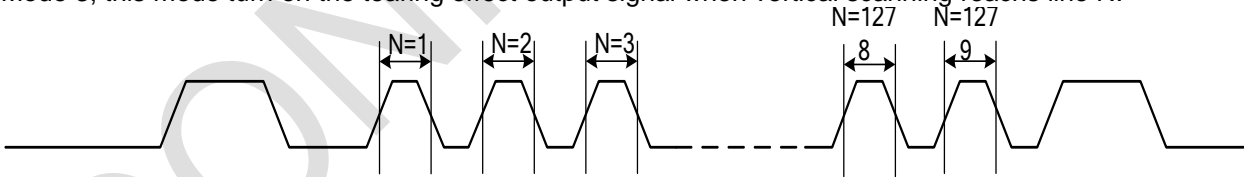

N = The N -th scanning line which set by register $N[15:0]$ of command `STESL`(44h).

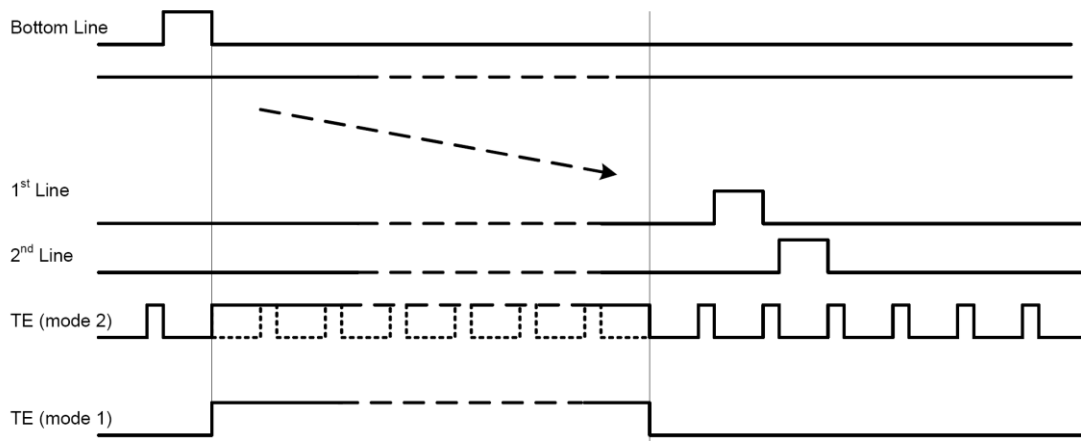

Note. During Sleep In mode, the tearing effect output signal is active low.

CONFIDENTIAL

5.5.2 Tearing Effect Line Timing

The tearing effect signal is described as below:

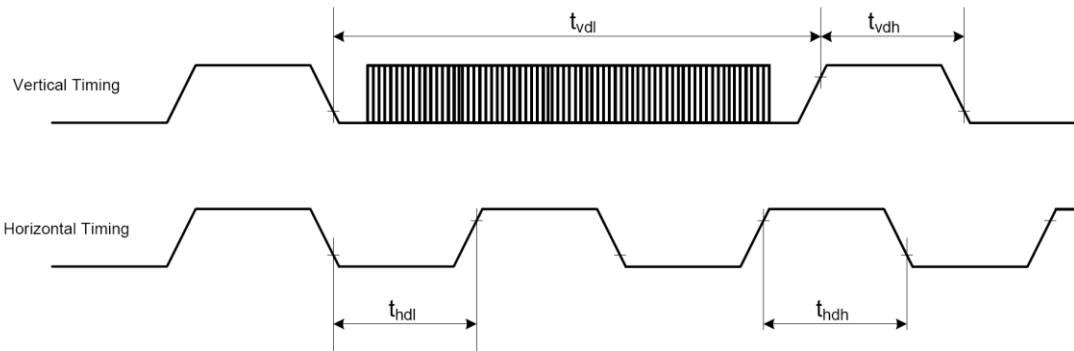

AC characteristics of Tearing Effect Signal (Frame Rate = 60.5Hz)

Symbol	Parameter	Typ.	Unit	Description
tvdl	Vertical timing low duration			1*frame time- tvdh
tvdh	Vertical timing high duration			tvdh =V Porch time if STS[15:0]=0. tvdh =31* line time if STS[15:0] not equal to 0.
thdl	Horizontal timing low duration			1* line time- 32*PCLK
thdh	Horizontal timing high duration	1.45	us	32*PCLK

Notes:

1. The timings apply when MADCTL B4=0 and B4=1
2. The signal's rise and fall times (t_f , t_r) are stipulated to be equal to or less than 15ns.

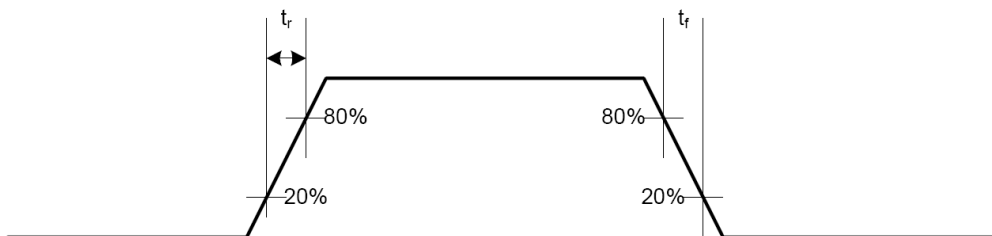

The Tearing Effect Output Line is fed back to the HOST and should be used as shown below to avoid tearing effect:

The Tearing Effect output line supplies to the HOST a panel synchronization signal. This signal can be enabled or disabled by the set_tear_off(34h), set_tear_on(35h) commands. The mode of the Tearing Effect Signal is defined by the Parameter of the Tearing Effect Line On command. The signal can be used by the HOST to synchronize internal VSYNC when displaying video images.

TEON (35h)	TELOM (35h, 1 st bit)	TE signal Output
0	*	GND
1	0	TE (Mode 1)
1	1	TE (Mode 2)

6. Command

6.1 Command List

Command			W/R	Function	D7	D6	D5	D4	D3	D2	D1	D0	Default (hex)	MTP
Page	Add.	Para.												
CMD1	00h	-	W	NOP	No Argument							-	-	
CMD1	01h	-	W	Software reset	No Argument							-	-	
CMD1	04h	1st	R	Read display identification information	ID1[7:0]							00h	-	
CMD1	04h	2nd			ID2[7:0]							80h	-	
CMD1	04h	3rd			ID3[7:0]							00h	-	
CMD1	05h	-	R	Read number of the errors on DSI	P[7:0]							00h	-	
CMD1	0Ah	1st	R	Read display power mode	BSTON	IDMON	PTLON	SLPOUT	NORON	DISPON	-	-	08h	-
CMD1	0Bh	1st	R	Read display MADCTR	MY	MX	-	-	RGB	-	-	-	00h	-
CMD1	0Ch	1st	R	Read display pixel format	SPI_IFPF_SEL	VIPF2	VIPF1	VIPF0	-	IFPF2	IFPF1	IFPF0	77h	-
CMD1	0Dh	1st	R	Read display image mode	0	0	INVON	ALLPON	ALLPOFF	0	0	0	00h	-
CMD1	0Eh	1st	R	Read display signal mode	TEON	M	0	0	0	0	0	ERR	00h	-
CMD1	0Fh	1st	R	Read display self-diagnostic result	0	0	0	0	0	0	0	checksum_comp	00h	-
CMD1	10h	-	W	Sleep-in	No Argument							-	-	
CMD1	11h	-	W	Sleep-out	No Argument							-	-	
CMD1	12h	-	W	Partial display mode on	No Argument							-	-	
CMD1	13h	-	W	Normal display mode on	No Argument							-	-	
CMD1	20h	-	W	Display inversion off	No Argument							-	-	
CMD1	21h	-	W	Display inversion on	No Argument							-	-	
CMD1	22h	-	W	All pixel off	No Argument							-	-	
CMD1	23h	-	W	All pixel on	No Argument							-	-	
CMD1	28h	-	W	Display off	No Argument							-	-	
CMD1	29h	-	W	Display on	No Argument							-	-	
CMD1	2Ah	1st	W	Set column start address	SC[9:8]							00h	-	
CMD1		2nd	W		SC[7:0]							00h	-	
CMD1		3rd	W		EC[9:8]							01h	-	
CMD1		4th	W		EC[7:0]							8Fh	-	
CMD1	2Bh	1st	W	Set row start address	SP[9:8]							00h	-	
CMD1		2nd	W		SP[7:0]							00h	-	
CMD1		3rd	W		EP[9:8]							01h	-	
CMD1		4th	W		EP[7:0]							8Fh	-	
CMD1	2Ch	-	W	Memory write	No Argument							-	-	
CMD1	30h	1st	W	Partial area	SR[9:8]							00h	-	
CMD1		2nd	W		SR[7:0]							00h	-	
CMD1		3rd	W		ER[9:8]							01h	-	
CMD1		4th	W		ER[7:0]							8Fh	-	
CMD1	31h	1st	W	Vertical partial area	PSC[9:8]							00h	-	
CMD1		2nd	W		PSC[7:0]							00h	-	
CMD1		3rd	W		PEC[9:8]							01h	-	
CMD1		4th	W		PEC[7:0]							8Fh	-	
CMD1	34h	-	W	Tearing effect line off	No Argument							-	-	
CMD1	35h	-	W	Tearing effect line on	0	0	0	0	0	0	TE_M	TELOM	00h	-
CMD1	36h	-	W	Scan direction control	MADCTR[7:0]							00h	-	
CMD1	38h	-	W	Idle mode off	No Argument							-	-	
CMD1	39h	-	W	Enter idle mode	No Argument							-	-	
CMD1	3Ah	-	W	Interface Pixel Format	SPI_IFPF_SEL	VIPF2	VIPF1	VIPF0	0	IFPF[2]	IFPF[1]	IFPF[0]	77h	-
CMD1	3Ch	-	W	Memory Continuous Write	No Argument							-	-	
CMD1	44h	1st	W	Set tear scan-line	STS[15:8]							00h	-	
CMD1		2nd	W		STS[7:0]							00h	-	
CMD1	45h	1st	R	Get scan line	GTS[15:8]							00h	-	

CMD1	2nd	R		GTS[7:0]								00h	-	
CMD1	4Fh	-	W	Deep standby	0	0	0	0	0	0	0	DSTB	00h	-
CMD1	51h	-	W	Write display brightness	DBV[7:0]								00h	-
CMD1	52h	-	R	Read display brightness	DBV[7:0]								00h	-
CMD1	53h	-	W	Write CTRL display	0	0	BCTRL	0	DD	0	0	0	28h	-
CMD1	54h	-	R	Read CTRL display	0	0	BCTRL	0	DD	0	0	0	28h	-
CMD1	55h	-	W	Write RAD_ACL function	0	0	0	0	0	RAD_ACL[1:0]			00h	
CMD1	56h	-	R	Read RAD_ACL function	0	0	0	0	0	RAD_ACL[1:0]			00h	
CMD1	58h	-	W	Set color enhancement	0	0	0	0	0	SLR_EN	SLR_LEVE L1	SLR_LEVE L0	00h	-
CMD1	59h	-	R	Read color enhancement	0	0	0	0	0	SLR_EN	SLR_LEVE L1	SLR_LEVE L0	00h	-
CMD1	63h	-	W	Write HBM display brightness	DBV_HBM[7:0]								00h	
CMD1	64h	-	R	Read HBM display brightness	DBV_HBM[7:0]								00h	
CMD1	66h		W	HBM enable	-	-	-	-	-	-	HBM_en	-	00h	
CMD1	67h		W	Deep idle enable	-	-	-	-	-	-	-	DEEP_IDL E_EN	00h	
CMD1		1st	W	COLSET	R_0000[7:0]								00h	
CMD1	70h	2nd	W	COLSET	G_0000[7:0]								00h	
CMD1		3rd	W	COLSET	B_0000[7:0]								00h	
CMD1		1st	W	COLSET	R_0001[7:0]								00h	
CMD1	71h	2nd	W	COLSET	G_0001[7:0]								00h	
CMD1		3rd	W	COLSET	B_0001[7:0]								FFh	
CMD1		1st	W	COLSET	R_0010[7:0]								00h	
CMD1	72h	2nd	W	COLSET	G_0010[7:0]								FFh	
CMD1		3rd	W	COLSET	B_0010[7:0]								00h	
CMD1		1st	W	COLSET	R_0011[7:0]								00h	
CMD1	73h	2nd	W	COLSET	G_0011[7:0]								FFh	
CMD1		3rd	W	COLSET	B_0011[7:0]								FFh	
CMD1		1st	W	COLSET	R_0100[7:0]								FFh	
CMD1	74h	2nd	W	COLSET	G_0100[7:0]								00h	
CMD1		3rd	W	COLSET	B_0100[7:0]								00h	
CMD1		1st	W	COLSET	R_0101[7:0]								FFh	
CMD1	75h	2nd	W	COLSET	G_0101[7:0]								00h	
CMD1		3rd	W	COLSET	B_0101[7:0]								FFh	
CMD1		1st	W	COLSET	R_0110[7:0]								FFh	
CMD1	76h	2nd	W	COLSET	G_0110[7:0]								FFh	
CMD1		3rd	W	COLSET	B_0110[7:0]								00h	
CMD1		1st	W	COLSET	R_0111[7:0]								FFh	
CMD1	77h	2nd	W	COLSET	G_0111[7:0]								FFh	
CMD1		3rd	W	COLSET	B_0111[7:0]								FFh	
CMD1		1st	W	COLSET	R_1000[7:0]								00h	
CMD1	78h	2nd	W	COLSET	G_1000[7:0]								00h	
CMD1		3rd	W	COLSET	B_1000[7:0]								00h	
CMD1		1st	W	COLSET	R_1001[7:0]								00h	
CMD1	79h	2nd	W	COLSET	G_1001[7:0]								00h	
CMD1		3rd	W	COLSET	B_1001[7:0]								FFh	
CMD1		1st	W	COLSET	R_1010[7:0]								00h	
CMD1	7Ah	2nd	W	COLSET	G_1010[7:0]								FFh	
CMD1		3rd	W	COLSET	B_1010[7:0]								00h	
CMD1		1st	W	COLSET	R_1011[7:0]								00h	
CMD1	7Bh	2nd	W	COLSET	G_1011[7:0]								FFh	
CMD1		3rd	W	COLSET	B_1011[7:0]								FFh	
CMD1		1st	W	COLSET	R_1100[7:0]								FFh	
CMD1	7Ch	2nd	W	COLSET	G_1100[7:0]								00h	
CMD1		3rd	W	COLSET	B_1100[7:0]								00h	
CMD1		1st	W	COLSET	R_1101[7:0]								FFh	
CMD1	7Dh	2nd	W	COLSET	G_1101[7:0]								00h	
CMD1		3rd	W	COLSET	B_1101[7:0]								FFh	

CMD1		1st	W	COLSET						R_1110[7:0]		FFh		
CMD1	7Eh	2nd	W	COLSET						G_1110[7:0]		FFh		
CMD1		3rd	W	COLSET						B_1110[7:0]		00h		
CMD1		1st	W	COLSET						R_1111[7:0]		FFh		
CMD1	7Fh	2nd	W	COLSET						G_1111[7:0]		FFh		
CMD1		3rd	W	COLSET						B_1111[7:0]		FFh		
CMD1	80h	1st	W	COLOPT	-	RGB111_o pt	-	-	RGB4bit_ en	gray256_col or[2]	gray256_c olor[1]	gray256_ color[0]	07h	
CMD1		1st	R	Read DDB	SID[7:0]							D0h	-	
CMD1		2nd	R		SID[15:8]							01h	-	
CMD1	A1h	3rd	R		MID[7:0]							80h	-	
CMD1		4th	R		MID[15:8]							90h	-	
CMD1		5th	R		1	1	1	1	1	1	1	1	1	FFh
CMD1		1st	R	Read DDB Continuous	SID[7:0]							D0h	-	
CMD1		2nd	R		SID[15:8]							01h	-	
CMD1	A8h	3rd	R		MID[7:0]							80h	-	
CMD1		4th	R		MID[15:8]							90h	-	
CMD1		5th	R		1	1	1	1	1	1	1	1	1	FFh
CMD1	AAh	-	R	Read first checksum	FCS[7:0]							00h	-	
CMD1	AFh	-	R	Read continuous checksum	CCS[7:0]							00h	-	
CMD1	C2h			Set_DSIP Mode	0	0	0	0	0	0	DM1	DM0	00h	-
CMD1	C4h			Set_DSPI Mode	SPI_WRA M	0	DSPI_CFG 1	DSPI_CFG 0	0	0	0	DSPI_EN	00h	-
CMD1	DAh	-	R	Read display identification information (the same as 04h)	ID1[7:0]							00h	-	
CMD1	DBh	-	R		ID2[7:0]							80h	-	
CMD1	DCh	-	R		ID3[7:0]							00h	-	
CMD1	FEh	-	W	Write CMD mode page	0	0	0	0	CMD_Page[3:0]			00h	-	
CMD1	FFh	-	R	Read CMD page Status	0	0	0	0	CMD_Status[3:0]			00h	-	

6.2 Command Description NOP (0000h)

0000H	NOP (No Operation)																								
Inst/Para	R/W	Address		D15-8	D7	D6	D5	D4	D3	D2	D1	D0	HEX												
		MIPI	Other																						
NOP	W	00h	0000h	No Argument																					
Description	This command is an empty command; it does not have any effect on the display module. X = Don't care.																								
Restriction	None																								
Register Availability	<table border="1"> <thead> <tr> <th>Status</th> <th>Availability</th> </tr> </thead> <tbody> <tr> <td>Normal Mode On, Idle Mode Off, Sleep Out</td> <td>Yes</td> </tr> <tr> <td>Normal Mode On, Idle Mode On, Sleep Out</td> <td>Yes</td> </tr> <tr> <td>Partial Mode On, Idle Mode Off, Sleep Out</td> <td>Yes</td> </tr> <tr> <td>Partial Mode On, Idle Mode On, Sleep Out</td> <td>Yes</td> </tr> <tr> <td>Sleep In</td> <td>Yes</td> </tr> </tbody> </table>													Status	Availability	Normal Mode On, Idle Mode Off, Sleep Out	Yes	Normal Mode On, Idle Mode On, Sleep Out	Yes	Partial Mode On, Idle Mode Off, Sleep Out	Yes	Partial Mode On, Idle Mode On, Sleep Out	Yes	Sleep In	Yes
Status	Availability																								
Normal Mode On, Idle Mode Off, Sleep Out	Yes																								
Normal Mode On, Idle Mode On, Sleep Out	Yes																								
Partial Mode On, Idle Mode Off, Sleep Out	Yes																								
Partial Mode On, Idle Mode On, Sleep Out	Yes																								
Sleep In	Yes																								
Default	<table border="1"> <thead> <tr> <th>Status</th> <th>Default Value</th> </tr> </thead> <tbody> <tr> <td>Power On Sequence</td> <td>N/A</td> </tr> <tr> <td>SW Reset</td> <td>N/A</td> </tr> <tr> <td>HW Reset</td> <td>N/A</td> </tr> </tbody> </table>													Status	Default Value	Power On Sequence	N/A	SW Reset	N/A	HW Reset	N/A				
Status	Default Value																								
Power On Sequence	N/A																								
SW Reset	N/A																								
HW Reset	N/A																								
Flow Chart	None																								

SWRESET(0100h) : Software Reset

0100H	SWRESET(Software Reset)																								
Inst/Para	R/W	Address		D15-8	D7	D6	D5	D4	D3	D2	D1	D0	HEX												
		MIPI	Other																						
SWRESET	W	01h	0100h	No Argument																					
Description	When the Software Reset command is written, it causes software reset. It resets the commands and parameters to their S/W Reset default values. (See default tables in each command description.)																								
Restriction	Software Reset Command cannot be sent during Sleep Out sequence. Any new command cannot be sent for 10-frame period until the RM69330 enters Sleep-In mode. Do not send any command.																								
Register Availability	<table border="1"> <thead> <tr> <th>Status</th> <th>Availability</th> </tr> </thead> <tbody> <tr> <td>Normal Mode On, Idle Mode Off, Sleep Out</td> <td>Yes</td> </tr> <tr> <td>Normal Mode On, Idle Mode On, Sleep Out</td> <td>Yes</td> </tr> <tr> <td>Partial Mode On, Idle Mode Off, Sleep Out</td> <td>Yes</td> </tr> <tr> <td>Partial Mode On, Idle Mode On, Sleep Out</td> <td>Yes</td> </tr> <tr> <td>Sleep In</td> <td>Yes</td> </tr> </tbody> </table>													Status	Availability	Normal Mode On, Idle Mode Off, Sleep Out	Yes	Normal Mode On, Idle Mode On, Sleep Out	Yes	Partial Mode On, Idle Mode Off, Sleep Out	Yes	Partial Mode On, Idle Mode On, Sleep Out	Yes	Sleep In	Yes
Status	Availability																								
Normal Mode On, Idle Mode Off, Sleep Out	Yes																								
Normal Mode On, Idle Mode On, Sleep Out	Yes																								
Partial Mode On, Idle Mode Off, Sleep Out	Yes																								
Partial Mode On, Idle Mode On, Sleep Out	Yes																								
Sleep In	Yes																								
Default	<table border="1"> <thead> <tr> <th>Status</th> <th>Default Value</th> </tr> </thead> <tbody> <tr> <td>Power On Sequence</td> <td>N/A</td> </tr> <tr> <td>SW Reset</td> <td>N/A</td> </tr> <tr> <td>HW Reset</td> <td>N/A</td> </tr> </tbody> </table>													Status	Default Value	Power On Sequence	N/A	SW Reset	N/A	HW Reset	N/A				
Status	Default Value																								
Power On Sequence	N/A																								
SW Reset	N/A																								
HW Reset	N/A																								
Flow Chart	<pre> graph TD A[SWRESET (01h)] --> B{{Display whole blank screen}} B --> C{{Set Commands to S/W Default Value}} C --> D([Sleep In Mode]) </pre> <p>Legend</p> <ul style="list-style-type: none"> Command: Rectangle Parameter: Parallelogram Display: Hexagon Action: Pentagon Mode: Oval Sequential transfer: Rounded rectangle 																								

RDDID(0400h~0402h) : Read Display ID

0400H	RDDID																										
Inst/Para	R/W	Address		D15-8	D7	D6	D5	D4	D3	D2	D1	D0	HEX														
		MIPI	Other																								
RDDID	R	04h	0400h	x	ID17	ID16	ID15	ID14	ID13	ID12	ID11	ID10	00														
			0401h	x	ID27	ID26	ID25	ID24	ID23	ID22	ID21	ID20	80														
			0402h	x	ID37	ID36	ID35	ID34	ID33	ID32	ID31	ID30	00														
Description	The 1 st parameter (ID1): the Module's manufacture ID The 2 nd parameter (ID2): the Module/driver version ID The 3 rd parameter (ID3): the Module/driver ID Note: Commands RDID1/2/3 (DAh/DBh/DCh) read data correspond to the parameter 1, 2, 3 of command 04h, respectively.																										
Restriction	-																										
Register Availability	<table border="1"> <thead> <tr> <th>Status</th> <th>Availability</th> </tr> </thead> <tbody> <tr> <td>Normal Mode On, Idle Mode Off, Sleep Out</td> <td>Yes</td> </tr> <tr> <td>Normal Mode On, Idle Mode On, Sleep Out</td> <td>Yes</td> </tr> <tr> <td>Partial Mode On, Idle Mode Off, Sleep Out</td> <td>Yes</td> </tr> <tr> <td>Partial Mode On, Idle Mode On, Sleep Out</td> <td>Yes</td> </tr> <tr> <td>Sleep In</td> <td>Yes</td> </tr> </tbody> </table>													Status	Availability	Normal Mode On, Idle Mode Off, Sleep Out	Yes	Normal Mode On, Idle Mode On, Sleep Out	Yes	Partial Mode On, Idle Mode Off, Sleep Out	Yes	Partial Mode On, Idle Mode On, Sleep Out	Yes	Sleep In	Yes		
Status	Availability																										
Normal Mode On, Idle Mode Off, Sleep Out	Yes																										
Normal Mode On, Idle Mode On, Sleep Out	Yes																										
Partial Mode On, Idle Mode Off, Sleep Out	Yes																										
Partial Mode On, Idle Mode On, Sleep Out	Yes																										
Sleep In	Yes																										
Default	<table border="1"> <thead> <tr> <th rowspan="2">Status</th> <th colspan="2">Default Value</th> </tr> <tr> <th>After MTP</th> <th>Before MTP</th> </tr> </thead> <tbody> <tr> <td>Power On Sequence</td> <td>MTP value</td> <td>ID1=00h / ID2=80h / ID3=00h</td> </tr> <tr> <td>SW Reset</td> <td>MTP value</td> <td>ID1=00h / ID2=80h / ID3=00h</td> </tr> <tr> <td>HW Reset</td> <td>MTP value</td> <td>ID1=00h / ID2=80h / ID3=00h</td> </tr> </tbody> </table>													Status	Default Value		After MTP	Before MTP	Power On Sequence	MTP value	ID1=00h / ID2=80h / ID3=00h	SW Reset	MTP value	ID1=00h / ID2=80h / ID3=00h	HW Reset	MTP value	ID1=00h / ID2=80h / ID3=00h
Status	Default Value																										
	After MTP	Before MTP																									
Power On Sequence	MTP value	ID1=00h / ID2=80h / ID3=00h																									
SW Reset	MTP value	ID1=00h / ID2=80h / ID3=00h																									
HW Reset	MTP value	ID1=00h / ID2=80h / ID3=00h																									
Flow Chart	<pre> graph TD A[RDDID (04h)] --> B[/Send 1st parameter ID1[7:0]/] B --> C[/Send 2nd parameter ID2[7:0]/] C --> D[/Send 3rd parameter ID3[7:0]/] </pre> <p>Legend</p> <ul style="list-style-type: none"> Command: Rectangle Parameter: Parallelogram Display: Hexagon Action: Pentagon Mode: Oval Sequential transfer: Oval with tail 																										

RDNUMED(0500h) : Read Number of Errors on DSI

0500H		RDNUMED																							
Inst/Para	R/W	Address		D15-8	D7	D6	D5	D4	D3	D2	D1	D0	HEX												
		MIPI	Other																						
RDNUMED	R	05h	0500h	x	D7	D6	D5	D4	D3	D2	D1	D0	00												
Description	<p>The first parameter is telling a number of the parity errors on DSI. The more detailed description of the bits is below. D[6..0] bits are telling a number of the parity errors. D[7] is set to "1" if there is overflow with D[6..0] bits. D[7..0] bits are set to "0"s (as well as RDDSM(0Eh)'s D0 are set "0" at the same time) after there is sent the first parameter information (= The read function is completed). This command is used for MIPI DSI only. It is no function for others interface operation.</p>																								
Restriction	-																								
Register Availability	<table border="1"> <thead> <tr> <th>Status</th> <th>Availability</th> </tr> </thead> <tbody> <tr> <td>Normal Mode On, Idle Mode Off, Sleep Out</td> <td>Yes</td> </tr> <tr> <td>Normal Mode On, Idle Mode On, Sleep Out</td> <td>Yes</td> </tr> <tr> <td>Partial Mode On, Idle Mode Off, Sleep Out</td> <td>Yes</td> </tr> <tr> <td>Partial Mode On, Idle Mode On, Sleep Out</td> <td>Yes</td> </tr> <tr> <td>Sleep In</td> <td>Yes</td> </tr> </tbody> </table>													Status	Availability	Normal Mode On, Idle Mode Off, Sleep Out	Yes	Normal Mode On, Idle Mode On, Sleep Out	Yes	Partial Mode On, Idle Mode Off, Sleep Out	Yes	Partial Mode On, Idle Mode On, Sleep Out	Yes	Sleep In	Yes
Status	Availability																								
Normal Mode On, Idle Mode Off, Sleep Out	Yes																								
Normal Mode On, Idle Mode On, Sleep Out	Yes																								
Partial Mode On, Idle Mode Off, Sleep Out	Yes																								
Partial Mode On, Idle Mode On, Sleep Out	Yes																								
Sleep In	Yes																								
Default	<table border="1"> <thead> <tr> <th>Status</th> <th>Default Value</th> </tr> </thead> <tbody> <tr> <td>Power On Sequence</td> <td>00h</td> </tr> <tr> <td>SW Reset</td> <td>00h</td> </tr> <tr> <td>HW Reset</td> <td>00h</td> </tr> </tbody> </table>													Status	Default Value	Power On Sequence	00h	SW Reset	00h	HW Reset	00h				
Status	Default Value																								
Power On Sequence	00h																								
SW Reset	00h																								
HW Reset	00h																								
Flow Chart	<pre> graph TD A[RDDID (05h)] --> B[/Send 1st parameter/] B --> C[/P[7:0]=00h RDDSM(0Eh)'s D0 = '0'/] </pre> <p>Legend</p> <ul style="list-style-type: none"> Command: Rectangle Parameter: Parallelogram Display: Hexagon Action: Arrowhead Mode: Oval Sequential transfer: Double arrow 																								

RDDPM (0A00h) : Read Display Power Mode

0A00H		RDDPM (Read Display Power Mode)																							
Inst/Para	R/W	Address		D15-8	D7	D6	D5	D4	D3	D2	D1	D0	HEX												
		MIPI	Other																						
RDDPM	R	0Ah	0A00h	x	D7	D6	D5	D4	D3	D2	D1	D0	08												
Description	This command indicates the current status of the display as described in the table below:																								
	Bit	Symbol	Description		Comment																				
	D7	BSTON	Booster Voltage Status		'1'=Booster on, '0'=Booster off																				
	D6	IDMON	Idle Mode On/Off		'1' = Idle Mode On, '0' = Idle Mode Off																				
	D5	PTLON	Partial Mode On/Off		'1' = Partial Mode On, '0' = Partial Mode Off																				
	D4	SLPON	Sleep In/Out		'1' = Sleep Out, '0' = Sleep In																				
	D3	NORON	Display Normal Mode On/Off		'1' = Normal Display, '0' = Partial Display																				
	D2	DISON	Display On/Off		'1' = Display On, '0' = Display Off																				
D1	Reserved			0																					
D0	Reserved			0																					
Register Availability	<table border="1"> <thead> <tr> <th>Status</th> <th>Availability</th> </tr> </thead> <tbody> <tr> <td>Normal Mode On, Idle Mode Off, Sleep Out</td> <td>Yes</td> </tr> <tr> <td>Normal Mode On, Idle Mode On, Sleep Out</td> <td>Yes</td> </tr> <tr> <td>Partial Mode On, Idle Mode Off, Sleep Out</td> <td>Yes</td> </tr> <tr> <td>Partial Mode On, Idle Mode On, Sleep Out</td> <td>Yes</td> </tr> <tr> <td>Sleep In</td> <td>Yes</td> </tr> </tbody> </table>													Status	Availability	Normal Mode On, Idle Mode Off, Sleep Out	Yes	Normal Mode On, Idle Mode On, Sleep Out	Yes	Partial Mode On, Idle Mode Off, Sleep Out	Yes	Partial Mode On, Idle Mode On, Sleep Out	Yes	Sleep In	Yes
	Status	Availability																							
	Normal Mode On, Idle Mode Off, Sleep Out	Yes																							
	Normal Mode On, Idle Mode On, Sleep Out	Yes																							
	Partial Mode On, Idle Mode Off, Sleep Out	Yes																							
	Partial Mode On, Idle Mode On, Sleep Out	Yes																							
Sleep In	Yes																								
Default	<table border="1"> <thead> <tr> <th>Status</th> <th>Default Value</th> </tr> </thead> <tbody> <tr> <td>Power On Sequence</td> <td>08h</td> </tr> <tr> <td>SW Reset</td> <td>08h</td> </tr> <tr> <td>HW Reset</td> <td>08h</td> </tr> </tbody> </table>													Status	Default Value	Power On Sequence	08h	SW Reset	08h	HW Reset	08h				
	Status	Default Value																							
	Power On Sequence	08h																							
	SW Reset	08h																							
HW Reset	08h																								
Flow Chart	<div style="display: flex; justify-content: space-around;"> <div style="text-align: center;"> <p>Serial I/F Mode</p> </div> <div style="text-align: center;"> <p>Parallel I/F Mode</p> </div> </div> <div style="margin-top: 20px;"> <p>Legend</p> <ul style="list-style-type: none"> Command: [Rectangle] Parameter: [Parallelogram] Display: [Oval] Action: [Arrow] Mode: [Rounded Rectangle] Sequential transfer: [Speech bubble] </div>																								

RDDMADCTR (0B00h): Read Display MADCTR

0B00H		RDDMADCTR (Read Display MADCTR)																						
Inst/Para	R/W	Address		D15-8	D7	D6	D5	D4	D3	D2	D1	D0	HEX											
		MIPI	Other																					
RDDMADCTR	R	0Bh	0B00h	x	D7	D6	D5	D4	D3	D2	D1	D0	00											
Description	This command indicates the current status of the display as described in the table below:																							
	Bit	Symbol	Description	Comment																				
	D7	MY	Row Address Increment	0: Increasing in vertical 1: Decreasing in vertical																				
	D6	MX	Column Address Increment	0: Increasing in horizontal 1: Decreasing in horizontal																				
	D3 others	Reserved	-	'1' =BGR, "0"=RGB -																				
Register Availability	<table border="1"> <thead> <tr> <th>Status</th> <th>Availability</th> </tr> </thead> <tbody> <tr> <td>Normal Mode On, Idle Mode Off, Sleep Out</td> <td>Yes</td> </tr> <tr> <td>Normal Mode On, Idle Mode On, Sleep Out</td> <td>Yes</td> </tr> <tr> <td>Partial Mode On, Idle Mode Off, Sleep Out</td> <td>Yes</td> </tr> <tr> <td>Partial Mode On, Idle Mode On, Sleep Out</td> <td>Yes</td> </tr> <tr> <td>Sleep In</td> <td>Yes</td> </tr> </tbody> </table>												Status	Availability	Normal Mode On, Idle Mode Off, Sleep Out	Yes	Normal Mode On, Idle Mode On, Sleep Out	Yes	Partial Mode On, Idle Mode Off, Sleep Out	Yes	Partial Mode On, Idle Mode On, Sleep Out	Yes	Sleep In	Yes
	Status	Availability																						
	Normal Mode On, Idle Mode Off, Sleep Out	Yes																						
	Normal Mode On, Idle Mode On, Sleep Out	Yes																						
	Partial Mode On, Idle Mode Off, Sleep Out	Yes																						
	Partial Mode On, Idle Mode On, Sleep Out	Yes																						
Sleep In	Yes																							
Default	<table border="1"> <thead> <tr> <th>Status</th> <th>Default Value</th> </tr> </thead> <tbody> <tr> <td>Power On Sequence</td> <td>00h</td> </tr> <tr> <td>SW Reset</td> <td>00h</td> </tr> <tr> <td>HW Reset</td> <td>00h</td> </tr> </tbody> </table>												Status	Default Value	Power On Sequence	00h	SW Reset	00h	HW Reset	00h				
	Status	Default Value																						
	Power On Sequence	00h																						
	SW Reset	00h																						
HW Reset	00h																							
Flow Chart	<div style="display: flex; justify-content: space-around;"> <div style="text-align: center;"> <p>Serial I/F Mode</p> </div> <div style="text-align: center;"> <p>Parallel I/F Mode</p> </div> </div> <div style="margin-top: 20px;"> <p>Legend</p> <ul style="list-style-type: none"> Command: [Rectangle] Parameter: [Parallelogram] Display: [Oval] Action: [Hexagon] Mode: [Rounded Rectangle] Sequential transfer: [Speech bubble] </div>																							

RDDCOLMOD (0C00h): Read Display Pixel Format

0C00H	RDDCOLMOD (Read Display Pixel Format)																																								
Inst/Para	R/W	Address		D15-8	D7	D6	D5	D4	D3	D2	D1	D0	HEX																												
		MIPI	Other																																						
RDDCOLMOD	R	0Ch	0C00h	x	SPI_I EPF	VIPF[0]	VIPF[0]	VIPF[0]	0	IFPF[2]	IFPF[1]	IFPF[0]	77																												
Description	<p>To return the status of 0x3A00.</p> <p>This command sets the pixel format for the RGB image data used by the interface. If SPI_IFPF_SEL(3Ah-B7) = 1: The VIPF[2:0] pixel format used by the SPI interface If SPI_IFPF_SEL(3Ah-B7) = 0: The IFPF[2:0] pixel format used by the SPI / MCU interface</p> <p>If not used DPI interface, then the corresponding bits in the parameter are ignored.</p> <table border="1"> <thead> <tr> <th>Control Interface Color Format</th> <th>IFPF[2]</th> <th>IFPF[1]</th> <th>IFPF[0]</th> </tr> </thead> <tbody> <tr> <td>SPI 8 bit/pixel (256 colors); SPI 256 Gray (Support IF: SPI3/SPI4)</td> <td>0</td> <td>0</td> <td>1</td> </tr> <tr> <td>SPI 8 bit/pixel (256 colors); SPI 3-3-2 (Support IF: SPI3/SPI4)</td> <td>0</td> <td>1</td> <td>0</td> </tr> <tr> <td>SPI 3 bit/pixel (8 colors); SPI 1-1-1 (Support IF: SPI3/SPI4)</td> <td>0</td> <td>1</td> <td>1</td> </tr> <tr> <td>16bit/pixel (65,536 colors)</td> <td>1</td> <td>0</td> <td>1</td> </tr> <tr> <td>18bit/pixel (262,144 colors)</td> <td>1</td> <td>1</td> <td>0</td> </tr> <tr> <td>24bit/pixel (16.7M colors)</td> <td>1</td> <td>1</td> <td>1</td> </tr> </tbody> </table>													Control Interface Color Format	IFPF[2]	IFPF[1]	IFPF[0]	SPI 8 bit/pixel (256 colors); SPI 256 Gray (Support IF: SPI3/SPI4)	0	0	1	SPI 8 bit/pixel (256 colors); SPI 3-3-2 (Support IF: SPI3/SPI4)	0	1	0	SPI 3 bit/pixel (8 colors); SPI 1-1-1 (Support IF: SPI3/SPI4)	0	1	1	16bit/pixel (65,536 colors)	1	0	1	18bit/pixel (262,144 colors)	1	1	0	24bit/pixel (16.7M colors)	1	1	1
	Control Interface Color Format	IFPF[2]	IFPF[1]	IFPF[0]																																					
SPI 8 bit/pixel (256 colors); SPI 256 Gray (Support IF: SPI3/SPI4)	0	0	1																																						
SPI 8 bit/pixel (256 colors); SPI 3-3-2 (Support IF: SPI3/SPI4)	0	1	0																																						
SPI 3 bit/pixel (8 colors); SPI 1-1-1 (Support IF: SPI3/SPI4)	0	1	1																																						
16bit/pixel (65,536 colors)	1	0	1																																						
18bit/pixel (262,144 colors)	1	1	0																																						
24bit/pixel (16.7M colors)	1	1	1																																						
Register Availability	<table border="1"> <thead> <tr> <th>Status</th> <th>Availability</th> </tr> </thead> <tbody> <tr> <td>Normal Mode On, Idle Mode Off, Sleep Out</td> <td>Yes</td> </tr> <tr> <td>Normal Mode On, Idle Mode On, Sleep Out</td> <td>Yes</td> </tr> <tr> <td>Partial Mode On, Idle Mode Off, Sleep Out</td> <td>Yes</td> </tr> <tr> <td>Partial Mode On, Idle Mode On, Sleep Out</td> <td>Yes</td> </tr> <tr> <td>Sleep In</td> <td>Yes</td> </tr> </tbody> </table>													Status	Availability	Normal Mode On, Idle Mode Off, Sleep Out	Yes	Normal Mode On, Idle Mode On, Sleep Out	Yes	Partial Mode On, Idle Mode Off, Sleep Out	Yes	Partial Mode On, Idle Mode On, Sleep Out	Yes	Sleep In	Yes																
Status	Availability																																								
Normal Mode On, Idle Mode Off, Sleep Out	Yes																																								
Normal Mode On, Idle Mode On, Sleep Out	Yes																																								
Partial Mode On, Idle Mode Off, Sleep Out	Yes																																								
Partial Mode On, Idle Mode On, Sleep Out	Yes																																								
Sleep In	Yes																																								
Default	<table border="1"> <thead> <tr> <th>Status</th> <th>Default Value</th> </tr> </thead> <tbody> <tr> <td>Power On Sequence</td> <td>77h</td> </tr> <tr> <td>SW Reset</td> <td>77h</td> </tr> <tr> <td>HW Reset</td> <td>77h</td> </tr> </tbody> </table>													Status	Default Value	Power On Sequence	77h	SW Reset	77h	HW Reset	77h																				
Status	Default Value																																								
Power On Sequence	77h																																								
SW Reset	77h																																								
HW Reset	77h																																								

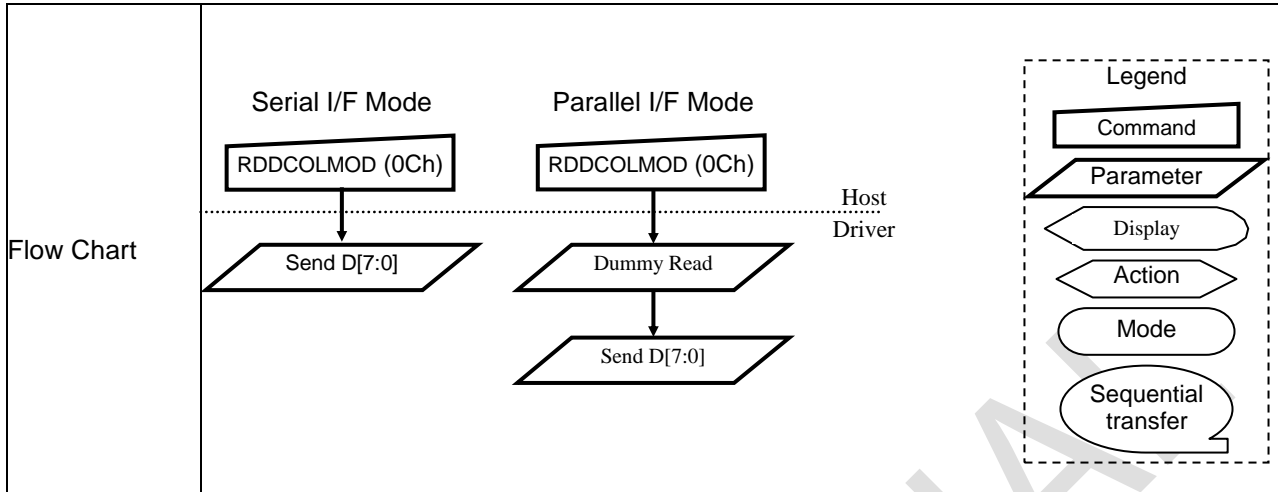

CONFIDENTIAL

RDDIM (0D00h): Read Display Image Mode

0d00H	RDDIM (Read Display Image Mode)																																								
Inst/Para	R/W	Address		D15-8	D7	D6	D5	D4	D3	D2	D1	D0	HEX																												
		MIPI	Other																																						
RDDIM	R	0Dh	0D00h	x	D7	D6	D5	D4	D3	D2	D1	D0	00																												
Description	The display module returns the display image mode status.																																								
	<table border="1"> <thead> <tr> <th>Bit</th> <th>Symbol</th> <th>Description</th> <th>Comment</th> </tr> </thead> <tbody> <tr> <td>D7</td> <td>Reserved</td> <td></td> <td>'0'</td> </tr> <tr> <td>D6</td> <td>Reserved</td> <td></td> <td>'0'</td> </tr> <tr> <td>D5</td> <td>INVON</td> <td>Inversion On/Off</td> <td>"1" = Inversion is On, "0" = Inversion is Off</td> </tr> <tr> <td>D4</td> <td>ALLON</td> <td>All Pixel On</td> <td>'0' = Normal display '1' = White display</td> </tr> <tr> <td>D3</td> <td>ALLOFF</td> <td>All Pixel Off</td> <td>'0' = Normal display '1' = Black display</td> </tr> <tr> <td>D2~D0</td> <td>Reserved</td> <td></td> <td>'000'</td> </tr> </tbody> </table>													Bit	Symbol	Description	Comment	D7	Reserved		'0'	D6	Reserved		'0'	D5	INVON	Inversion On/Off	"1" = Inversion is On, "0" = Inversion is Off	D4	ALLON	All Pixel On	'0' = Normal display '1' = White display	D3	ALLOFF	All Pixel Off	'0' = Normal display '1' = Black display	D2~D0	Reserved		'000'
	Bit	Symbol	Description	Comment																																					
	D7	Reserved		'0'																																					
	D6	Reserved		'0'																																					
	D5	INVON	Inversion On/Off	"1" = Inversion is On, "0" = Inversion is Off																																					
	D4	ALLON	All Pixel On	'0' = Normal display '1' = White display																																					
D3	ALLOFF	All Pixel Off	'0' = Normal display '1' = Black display																																						
D2~D0	Reserved		'000'																																						
Register Availability	<table border="1"> <thead> <tr> <th>Status</th> <th>Availability</th> </tr> </thead> <tbody> <tr> <td>Normal Mode On, Idle Mode Off, Sleep Out</td> <td>Yes</td> </tr> <tr> <td>Normal Mode On, Idle Mode On, Sleep Out</td> <td>Yes</td> </tr> <tr> <td>Partial Mode On, Idle Mode Off, Sleep Out</td> <td>Yes</td> </tr> <tr> <td>Partial Mode On, Idle Mode On, Sleep Out</td> <td>Yes</td> </tr> <tr> <td>Sleep In</td> <td>Yes</td> </tr> </tbody> </table>													Status	Availability	Normal Mode On, Idle Mode Off, Sleep Out	Yes	Normal Mode On, Idle Mode On, Sleep Out	Yes	Partial Mode On, Idle Mode Off, Sleep Out	Yes	Partial Mode On, Idle Mode On, Sleep Out	Yes	Sleep In	Yes																
	Status	Availability																																							
	Normal Mode On, Idle Mode Off, Sleep Out	Yes																																							
	Normal Mode On, Idle Mode On, Sleep Out	Yes																																							
	Partial Mode On, Idle Mode Off, Sleep Out	Yes																																							
	Partial Mode On, Idle Mode On, Sleep Out	Yes																																							
Sleep In	Yes																																								
Default	<table border="1"> <thead> <tr> <th>Status</th> <th>Default Value</th> </tr> </thead> <tbody> <tr> <td>Power On Sequence</td> <td>00h</td> </tr> <tr> <td>SW Reset</td> <td>00h</td> </tr> <tr> <td>HW Reset</td> <td>00h</td> </tr> </tbody> </table>													Status	Default Value	Power On Sequence	00h	SW Reset	00h	HW Reset	00h																				
	Status	Default Value																																							
	Power On Sequence	00h																																							
	SW Reset	00h																																							
HW Reset	00h																																								
Flow Chart	<div style="display: flex; justify-content: space-around;"> <div style="text-align: center;"> <p>Serial I/F Mode</p> </div> <div style="text-align: center;"> <p>Parallel I/F Mode</p> </div> </div> <p style="text-align: center; margin-top: 10px;">Host Driver</p> <div style="border: 1px dashed black; padding: 5px; margin-top: 10px;"> <p style="text-align: center;">Legend</p> <ul style="list-style-type: none"> Command: [Box] Parameter: [Parallelogram] Display: [Oval] Action: [Arrow] Mode: [Circle] Sequential transfer: [Speech bubble] </div>																																								

RDDSM (0E00h): Read Display Signal Mode

0E00H		RDDSM (Read Display Signal Mode)																							
Inst/Para	R/W	Address		D15-8	D7	D6	D5	D4	D3	D2	D1	D0	HEX												
		MIPI	Other																						
RDDSM	R	0Eh	0E00h	x	D7	D6	D5	D4	D3	D2	D1	D0	00												
Description	The display module returns the Display Signal Mode.																								
	Bit	Symbol	Description	Comment																					
	D7	TEON	Tearing Effect Line On/Off	"1" = On, "0" = Off																					
	D6	TELOM	Tearing effect line mode	"0" = mode1, "1" = mode2																					
	D5	Reserved		'0'																					
	D4	Reserved		'0'																					
	D3	Reserved		'0'																					
	D2	Reserved		'0'																					
	D1	Reserved		'0'																					
D0	Error on DSI	Error on DSI	'0' = No Error '1' = Error																						
Register Availability	<table border="1"> <thead> <tr> <th>Status</th> <th>Availability</th> </tr> </thead> <tbody> <tr> <td>Normal Mode On, Idle Mode Off, Sleep Out</td> <td>Yes</td> </tr> <tr> <td>Normal Mode On, Idle Mode On, Sleep Out</td> <td>Yes</td> </tr> <tr> <td>Partial Mode On, Idle Mode Off, Sleep Out</td> <td>Yes</td> </tr> <tr> <td>Partial Mode On, Idle Mode On, Sleep Out</td> <td>Yes</td> </tr> <tr> <td>Sleep In</td> <td>Yes</td> </tr> </tbody> </table>													Status	Availability	Normal Mode On, Idle Mode Off, Sleep Out	Yes	Normal Mode On, Idle Mode On, Sleep Out	Yes	Partial Mode On, Idle Mode Off, Sleep Out	Yes	Partial Mode On, Idle Mode On, Sleep Out	Yes	Sleep In	Yes
	Status	Availability																							
	Normal Mode On, Idle Mode Off, Sleep Out	Yes																							
	Normal Mode On, Idle Mode On, Sleep Out	Yes																							
	Partial Mode On, Idle Mode Off, Sleep Out	Yes																							
	Partial Mode On, Idle Mode On, Sleep Out	Yes																							
Sleep In	Yes																								
Default	<table border="1"> <thead> <tr> <th>Status</th> <th>Default Value</th> </tr> </thead> <tbody> <tr> <td>Power On Sequence</td> <td>00h</td> </tr> <tr> <td>SW Reset</td> <td>00h</td> </tr> <tr> <td>HW Reset</td> <td>00h</td> </tr> </tbody> </table>													Status	Default Value	Power On Sequence	00h	SW Reset	00h	HW Reset	00h				
	Status	Default Value																							
	Power On Sequence	00h																							
	SW Reset	00h																							
HW Reset	00h																								
Flow Chart	<div style="display: flex; justify-content: space-around;"> <div style="text-align: center;"> <p>Serial I/F Mode</p> </div> <div style="text-align: center;"> <p>Parallel I/F Mode</p> </div> </div> <p style="text-align: center; margin-top: 10px;">Host Driver</p>																								
	<div style="border: 1px dashed black; padding: 5px;"> <p>Legend</p> <ul style="list-style-type: none"> Command Parameter Display Action Mode Sequential transfer </div>																								

RDDSDR (0F00h): Read Display Self-Diagnostic Result

0F00H		RDDSDR (Read Display Self-Diagnostic Result)																							
Inst/Para	R/W	Address		D15-8	D7	D6	D5	D4	D3	D2	D1	D0	HEX												
		MIPI	Other																						
RDDSDR	R	0Fh	0F00h	x	0	0	0	0	0	0	0	checksum_comp	00												
Description	The display module returns the self-diagnostic results following a Sleep Out command.																								
	<table border="1"> <thead> <tr> <th>Bit</th> <th>Symbol</th> <th>Description</th> <th>Comment</th> </tr> </thead> <tbody> <tr> <td>D0</td> <td>Reserved</td> <td>checksum_comp</td> <td>'0'</td> </tr> </tbody> </table>													Bit	Symbol	Description	Comment	D0	Reserved	checksum_comp	'0'				
Bit	Symbol	Description	Comment																						
D0	Reserved	checksum_comp	'0'																						
Register Availability	<table border="1"> <thead> <tr> <th>Status</th> <th>Availability</th> </tr> </thead> <tbody> <tr> <td>Normal Mode On, Idle Mode Off, Sleep Out</td> <td>Yes</td> </tr> <tr> <td>Normal Mode On, Idle Mode On, Sleep Out</td> <td>Yes</td> </tr> <tr> <td>Partial Mode On, Idle Mode Off, Sleep Out</td> <td>Yes</td> </tr> <tr> <td>Partial Mode On, Idle Mode On, Sleep Out</td> <td>Yes</td> </tr> <tr> <td>Sleep In</td> <td>Yes</td> </tr> </tbody> </table>													Status	Availability	Normal Mode On, Idle Mode Off, Sleep Out	Yes	Normal Mode On, Idle Mode On, Sleep Out	Yes	Partial Mode On, Idle Mode Off, Sleep Out	Yes	Partial Mode On, Idle Mode On, Sleep Out	Yes	Sleep In	Yes
	Status	Availability																							
Normal Mode On, Idle Mode Off, Sleep Out	Yes																								
Normal Mode On, Idle Mode On, Sleep Out	Yes																								
Partial Mode On, Idle Mode Off, Sleep Out	Yes																								
Partial Mode On, Idle Mode On, Sleep Out	Yes																								
Sleep In	Yes																								
Default	<table border="1"> <thead> <tr> <th>Status</th> <th>Default Value</th> </tr> </thead> <tbody> <tr> <td>Power On Sequence</td> <td>00h</td> </tr> <tr> <td>SW Reset</td> <td>00h</td> </tr> <tr> <td>HW Reset</td> <td>00h</td> </tr> </tbody> </table>													Status	Default Value	Power On Sequence	00h	SW Reset	00h	HW Reset	00h				
	Status	Default Value																							
Power On Sequence	00h																								
SW Reset	00h																								
HW Reset	00h																								
Flow Chart	<div style="display: flex; justify-content: space-around;"> <div style="text-align: center;"> <p>Serial I/F Mode</p> </div> <div style="text-align: center;"> <p>Parallel I/F Mode</p> </div> </div> <div style="margin-top: 10px; text-align: center;"> <p>Host Driver</p> </div> <div style="border: 1px dashed black; padding: 5px; margin-top: 10px;"> <p>Legend</p> <ul style="list-style-type: none"> Command Parameter Display Action Mode Sequential transfer </div>																								

SLPIN (1000h): Sleep In

1000H	SLPIN (Sleep In)																								
Inst/Para	R/W	Address		D15-8	D7	D6	D5	D4	D3	D2	D1	D0	HEX												
		MIPI	Other																						
SLPIN	W	10h	1000h	No Argument																					
Description	<p>This command causes the display module to enter the minimum power consumption mode. In this mode the DC/DC converter is stopped, Internal display oscillator is stopped, and panel scanning is stopped. The control Interface such as registers is still working and keeps its values.</p> <p>After Sleep in command, user can send PCLK, HS and VS information on RGB I/F for blank display and this information is valid during 2 frames if there is used Normal Mode On in Sleep Out-mode.</p> <p>There is used an internal oscillator for blank display.</p>																								
Restriction	<p>This command has no effect when the display module is already in Sleep mode. Sleep In Mode can only be exit by the Sleep Out Command (11h).</p> <p>It must wait 5msec before sending next command for the supply voltages and clock circuits to stabilize.</p> <p>It must wait 120msec after sending Sleep Out command (when in Sleep In Mode) before Sleep In command can be sent.</p>																								
Register Availability	<table border="1"> <thead> <tr> <th>Status</th> <th>Availability</th> </tr> </thead> <tbody> <tr> <td>Normal Mode On, Idle Mode Off, Sleep Out</td> <td>Yes</td> </tr> <tr> <td>Normal Mode On, Idle Mode On, Sleep Out</td> <td>Yes</td> </tr> <tr> <td>Partial Mode On, Idle Mode Off, Sleep Out</td> <td>Yes</td> </tr> <tr> <td>Partial Mode On, Idle Mode On, Sleep Out</td> <td>Yes</td> </tr> <tr> <td>Sleep In</td> <td>Yes</td> </tr> </tbody> </table>													Status	Availability	Normal Mode On, Idle Mode Off, Sleep Out	Yes	Normal Mode On, Idle Mode On, Sleep Out	Yes	Partial Mode On, Idle Mode Off, Sleep Out	Yes	Partial Mode On, Idle Mode On, Sleep Out	Yes	Sleep In	Yes
Status	Availability																								
Normal Mode On, Idle Mode Off, Sleep Out	Yes																								
Normal Mode On, Idle Mode On, Sleep Out	Yes																								
Partial Mode On, Idle Mode Off, Sleep Out	Yes																								
Partial Mode On, Idle Mode On, Sleep Out	Yes																								
Sleep In	Yes																								
Default	<table border="1"> <thead> <tr> <th>Status</th> <th>Default Value</th> </tr> </thead> <tbody> <tr> <td>Power On Sequence</td> <td>Sleep In Mode</td> </tr> <tr> <td>SW Reset</td> <td>Sleep In Mode</td> </tr> <tr> <td>HW Reset</td> <td>Sleep In Mode</td> </tr> </tbody> </table>													Status	Default Value	Power On Sequence	Sleep In Mode	SW Reset	Sleep In Mode	HW Reset	Sleep In Mode				
Status	Default Value																								
Power On Sequence	Sleep In Mode																								
SW Reset	Sleep In Mode																								
HW Reset	Sleep In Mode																								

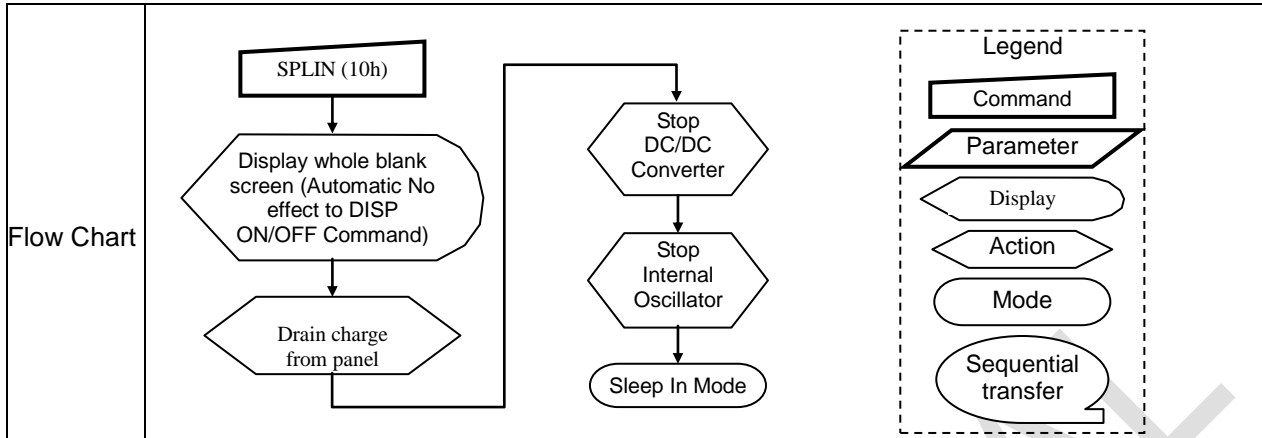

CONFIDENTIAL

SLPOUT (1100h): Sleep Out

1100H	SLPOUT (Sleep Out)																								
Inst/Para	R/W	Address		D15-8	D7	D6	D5	D4	D3	D2	D1	D0	HEX												
		MIPI	Other																						
SLPOUT	W	11h	1100h	No Argument																					
Description	This command causes the display module to exit Sleep mode. All blocks inside the display module are enabled. The host processor sends PCLK, HS and VS information to display modules two frames before this command is sent when the display module is in Normal Mode.																								
Restriction	This command shall not cause any visible effect on the display device when the display module is not in Sleep mode. The host processor must wait five milliseconds after sending this command before sending another command. This delay allows the supply voltages and clock circuits to stabilize. The host processor must wait 120 milliseconds after sending a Sleep Out command before sending a Sleep-In command. The display module loads the display module's default values to the registers when exiting the Sleep mode. There shall not be any abnormal visual effect on the display device when loading the registers if the factory default and register values are the same or when the display module is not in Sleep mode. The display module runs the self-diagnostic functions after this command is received.																								
Register Availability	<table border="1"> <thead> <tr> <th>Status</th> <th>Availability</th> </tr> </thead> <tbody> <tr> <td>Normal Mode On, Idle Mode Off, Sleep Out</td> <td>Yes</td> </tr> <tr> <td>Normal Mode On, Idle Mode On, Sleep Out</td> <td>Yes</td> </tr> <tr> <td>Partial Mode On, Idle Mode Off, Sleep Out</td> <td>Yes</td> </tr> <tr> <td>Partial Mode On, Idle Mode On, Sleep Out</td> <td>Yes</td> </tr> <tr> <td>Sleep In</td> <td>Yes</td> </tr> </tbody> </table>													Status	Availability	Normal Mode On, Idle Mode Off, Sleep Out	Yes	Normal Mode On, Idle Mode On, Sleep Out	Yes	Partial Mode On, Idle Mode Off, Sleep Out	Yes	Partial Mode On, Idle Mode On, Sleep Out	Yes	Sleep In	Yes
Status	Availability																								
Normal Mode On, Idle Mode Off, Sleep Out	Yes																								
Normal Mode On, Idle Mode On, Sleep Out	Yes																								
Partial Mode On, Idle Mode Off, Sleep Out	Yes																								
Partial Mode On, Idle Mode On, Sleep Out	Yes																								
Sleep In	Yes																								
Default	<table border="1"> <thead> <tr> <th>Status</th> <th>Default Value</th> </tr> </thead> <tbody> <tr> <td>Power On Sequence</td> <td>Sleep In Mode</td> </tr> <tr> <td>SW Reset</td> <td>Sleep In Mode</td> </tr> <tr> <td>HW Reset</td> <td>Sleep In Mode</td> </tr> </tbody> </table>													Status	Default Value	Power On Sequence	Sleep In Mode	SW Reset	Sleep In Mode	HW Reset	Sleep In Mode				
Status	Default Value																								
Power On Sequence	Sleep In Mode																								
SW Reset	Sleep In Mode																								
HW Reset	Sleep In Mode																								

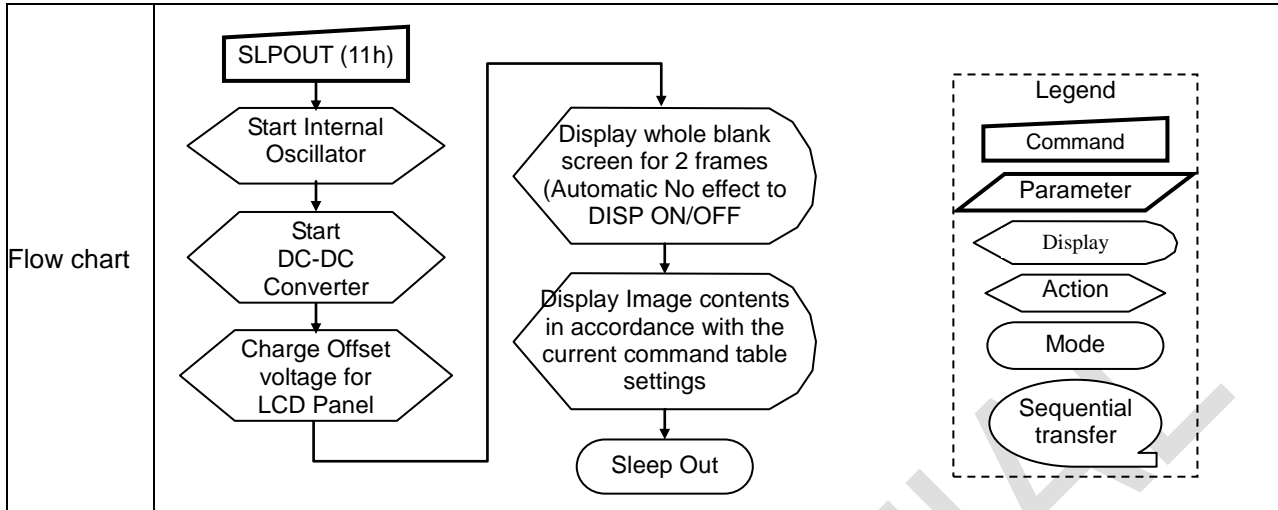

CONFIDENTIAL

PTLON (1200h): Partial Display Mode On

1200H	PTLON (Partial Display Mode On)																								
Inst/Para	R/W	Address		D15-8	D7	D6	D5	D4	D3	D2	D1	D0	HEX												
		MIPI	Other																						
PTLON	W	12h	1200h	No Argument																					
Description	<p>This command causes the display module to enter the Partial Display Mode. The Partial Display Mode window is described by the Partial Area (30h) command.</p> <p>To leave Partial Display Mode, the Normal Display Mode On (13h) command should be written. The host processor continues to send PCLK, HS and VS information to display modules for two frames after this command is sent when the display module is in Normal Display Mode.</p>																								
Restriction	This command has no effect when Partial Display Mode is already active.																								
Register Availability	<table border="1"> <thead> <tr> <th>Status</th> <th>Availability</th> </tr> </thead> <tbody> <tr> <td>Normal Mode On, Idle Mode Off, Sleep Out</td> <td>Yes</td> </tr> <tr> <td>Normal Mode On, Idle Mode On, Sleep Out</td> <td>Yes</td> </tr> <tr> <td>Partial Mode On, Idle Mode Off, Sleep Out</td> <td>Yes</td> </tr> <tr> <td>Partial Mode On, Idle Mode On, Sleep Out</td> <td>Yes</td> </tr> <tr> <td>Sleep In</td> <td>Yes</td> </tr> </tbody> </table>													Status	Availability	Normal Mode On, Idle Mode Off, Sleep Out	Yes	Normal Mode On, Idle Mode On, Sleep Out	Yes	Partial Mode On, Idle Mode Off, Sleep Out	Yes	Partial Mode On, Idle Mode On, Sleep Out	Yes	Sleep In	Yes
Status	Availability																								
Normal Mode On, Idle Mode Off, Sleep Out	Yes																								
Normal Mode On, Idle Mode On, Sleep Out	Yes																								
Partial Mode On, Idle Mode Off, Sleep Out	Yes																								
Partial Mode On, Idle Mode On, Sleep Out	Yes																								
Sleep In	Yes																								
Default	<table border="1"> <thead> <tr> <th>Status</th> <th>Default Value</th> </tr> </thead> <tbody> <tr> <td>Power On Sequence</td> <td>Normal display mode On</td> </tr> <tr> <td>SW Reset</td> <td>Normal display mode On</td> </tr> <tr> <td>HW Reset</td> <td>Normal display mode On</td> </tr> </tbody> </table>													Status	Default Value	Power On Sequence	Normal display mode On	SW Reset	Normal display mode On	HW Reset	Normal display mode On				
Status	Default Value																								
Power On Sequence	Normal display mode On																								
SW Reset	Normal display mode On																								
HW Reset	Normal display mode On																								
Flow Chart	Refer to Partial Area (30h)																								

NORON (1300h): Normal Display Mode On

1300H	NORON (Normal Display Mode On)																								
Inst/Para	R/W	Address		D15-8	D7	D6	D5	D4	D3	D2	D1	D0	HEX												
		MIPI	Other																						
NORON	W	13h	1300h	No Argument																					
Description	This command causes the display module to enter the Normal mode. Normal Mode is defined as Partial Display mode. The host processor sends PCLK, HS and VS information to Type 2 display modules two frames before this command is sent when the display module is in Partial Display Mode.																								
Restriction	This command has no effect when Normal Display mode is already active.																								
Register Availability	<table border="1"> <thead> <tr> <th>Status</th> <th>Availability</th> </tr> </thead> <tbody> <tr> <td>Normal Mode On, Idle Mode Off, Sleep Out</td> <td>Yes</td> </tr> <tr> <td>Normal Mode On, Idle Mode On, Sleep Out</td> <td>Yes</td> </tr> <tr> <td>Partial Mode On, Idle Mode Off, Sleep Out</td> <td>Yes</td> </tr> <tr> <td>Partial Mode On, Idle Mode On, Sleep Out</td> <td>Yes</td> </tr> <tr> <td>Sleep In</td> <td>Yes</td> </tr> </tbody> </table>													Status	Availability	Normal Mode On, Idle Mode Off, Sleep Out	Yes	Normal Mode On, Idle Mode On, Sleep Out	Yes	Partial Mode On, Idle Mode Off, Sleep Out	Yes	Partial Mode On, Idle Mode On, Sleep Out	Yes	Sleep In	Yes
Status	Availability																								
Normal Mode On, Idle Mode Off, Sleep Out	Yes																								
Normal Mode On, Idle Mode On, Sleep Out	Yes																								
Partial Mode On, Idle Mode Off, Sleep Out	Yes																								
Partial Mode On, Idle Mode On, Sleep Out	Yes																								
Sleep In	Yes																								
Default	<table border="1"> <thead> <tr> <th>Status</th> <th>Default Value</th> </tr> </thead> <tbody> <tr> <td>Power On Sequence</td> <td>Normal Display Mode On</td> </tr> <tr> <td>SW Reset</td> <td>Normal Display Mode On</td> </tr> <tr> <td>HW Reset</td> <td>Normal Display Mode On</td> </tr> </tbody> </table>													Status	Default Value	Power On Sequence	Normal Display Mode On	SW Reset	Normal Display Mode On	HW Reset	Normal Display Mode On				
Status	Default Value																								
Power On Sequence	Normal Display Mode On																								
SW Reset	Normal Display Mode On																								
HW Reset	Normal Display Mode On																								
Flow Chart	Refer to the description of Partial Area (3000h)																								

INVOFF (2000H): Display Inversion Off

2000H		INVOFF (Display Inversion Off)																							
Inst/Para	R/W	Address		D15-8	D7	D6	D5	D4	D3	D2	D1	D0	HEX												
		MIPI	Other																						
INVOFF	W	20h	2000h	No Argument																					
Description	<p>This command causes the display module to stop inverting the image data on the display device. No status bits are changed.</p> <div style="display: flex; justify-content: space-around; align-items: center;"> <div style="text-align: center;"> <p>Input Image</p> </div> <div style="font-size: 2em; margin: 0 20px;">→</div> <div style="text-align: center;"> <p>Display Panel</p> </div> </div>																								
Restriction	This command has no effect when the display module is not inverting the display image.																								
Register Availability	<table border="1" style="width: 100%; border-collapse: collapse;"> <thead> <tr> <th>Status</th> <th>Availability</th> </tr> </thead> <tbody> <tr> <td>Normal Mode On, Idle Mode Off, Sleep Out</td> <td>Yes</td> </tr> <tr> <td>Normal Mode On, Idle Mode On, Sleep Out</td> <td>Yes</td> </tr> <tr> <td>Partial Mode On, Idle Mode Off, Sleep Out</td> <td>Yes</td> </tr> <tr> <td>Partial Mode On, Idle Mode On, Sleep Out</td> <td>Yes</td> </tr> <tr> <td>Sleep In</td> <td>Yes</td> </tr> </tbody> </table>													Status	Availability	Normal Mode On, Idle Mode Off, Sleep Out	Yes	Normal Mode On, Idle Mode On, Sleep Out	Yes	Partial Mode On, Idle Mode Off, Sleep Out	Yes	Partial Mode On, Idle Mode On, Sleep Out	Yes	Sleep In	Yes
Status	Availability																								
Normal Mode On, Idle Mode Off, Sleep Out	Yes																								
Normal Mode On, Idle Mode On, Sleep Out	Yes																								
Partial Mode On, Idle Mode Off, Sleep Out	Yes																								
Partial Mode On, Idle Mode On, Sleep Out	Yes																								
Sleep In	Yes																								
Default	<table border="1" style="width: 100%; border-collapse: collapse;"> <thead> <tr> <th>Status</th> <th>Default Value</th> </tr> </thead> <tbody> <tr> <td>Power On Sequence</td> <td>Display Inversion off</td> </tr> <tr> <td>SW Reset</td> <td>Display Inversion off</td> </tr> <tr> <td>HW Reset</td> <td>Display Inversion off</td> </tr> </tbody> </table>													Status	Default Value	Power On Sequence	Display Inversion off	SW Reset	Display Inversion off	HW Reset	Display Inversion off				
Status	Default Value																								
Power On Sequence	Display Inversion off																								
SW Reset	Display Inversion off																								
HW Reset	Display Inversion off																								
Flow Chart	<div style="display: flex; align-items: center;"> <div style="flex: 1;"> <pre> graph TD A([Display Inversion On Mode]) --> B[INVOFF (20h)] B --> C([Display Inversion OFF Mode]) </pre> </div> <div style="flex: 0.5; border: 1px dashed black; padding: 5px; margin-left: 20px;"> <p>Legend</p> <ul style="list-style-type: none"> Command Parameter Display Action Mode Sequential transfer </div> </div>																								

INVON (2100H): Display Inversion On

2100H		INVON (Display Inversion On)																							
Inst/Para	R/W	Address		D15-8	D7	D6	D5	D4	D3	D2	D1	D0	HEX												
		MIPI	Other																						
INVON	W	21h	2100h	No Argument																					
Description	<p>This command causes the display module to invert the image data only on the display device. No status bits are changed.</p> <div style="display: flex; justify-content: space-around; align-items: center;"> <div style="text-align: center;"> <p>Input Image</p> </div> <div style="font-size: 2em;">→</div> <div style="text-align: center;"> <p>Display Panel</p> </div> </div>																								
Restriction	This command has no effect when module is already in inversion on mode.																								
Register Availability	<table border="1" style="width: 100%; border-collapse: collapse;"> <thead> <tr> <th>Status</th> <th>Availability</th> </tr> </thead> <tbody> <tr> <td>Normal Mode On, Idle Mode Off, Sleep Out</td> <td>Yes</td> </tr> <tr> <td>Normal Mode On, Idle Mode On, Sleep Out</td> <td>Yes</td> </tr> <tr> <td>Partial Mode On, Idle Mode Off, Sleep Out</td> <td>Yes</td> </tr> <tr> <td>Partial Mode On, Idle Mode On, Sleep Out</td> <td>Yes</td> </tr> <tr> <td>Sleep In</td> <td>Yes</td> </tr> </tbody> </table>													Status	Availability	Normal Mode On, Idle Mode Off, Sleep Out	Yes	Normal Mode On, Idle Mode On, Sleep Out	Yes	Partial Mode On, Idle Mode Off, Sleep Out	Yes	Partial Mode On, Idle Mode On, Sleep Out	Yes	Sleep In	Yes
Status	Availability																								
Normal Mode On, Idle Mode Off, Sleep Out	Yes																								
Normal Mode On, Idle Mode On, Sleep Out	Yes																								
Partial Mode On, Idle Mode Off, Sleep Out	Yes																								
Partial Mode On, Idle Mode On, Sleep Out	Yes																								
Sleep In	Yes																								
Default	<table border="1" style="width: 100%; border-collapse: collapse;"> <thead> <tr> <th>Status</th> <th>Default Value</th> </tr> </thead> <tbody> <tr> <td>Power On Sequence</td> <td>Display Inversion off</td> </tr> <tr> <td>SW Reset</td> <td>Display Inversion off</td> </tr> <tr> <td>HW Reset</td> <td>Display Inversion off</td> </tr> </tbody> </table>													Status	Default Value	Power On Sequence	Display Inversion off	SW Reset	Display Inversion off	HW Reset	Display Inversion off				
Status	Default Value																								
Power On Sequence	Display Inversion off																								
SW Reset	Display Inversion off																								
HW Reset	Display Inversion off																								
Flow Chart	<div style="display: flex; align-items: center;"> <div style="flex: 1;"> <pre> graph TD A([Display Inversion OFF Mode]) --> B[INVON (21h)] B --> C([Display Inversion ON Mode]) </pre> </div> <div style="flex: 1; border: 1px dashed black; padding: 5px;"> <p>Legend</p> <ul style="list-style-type: none"> Command Parameter Display Action Mode Sequential transfer </div> </div>																								

ALLPOFF (2200H): All Pixel Off

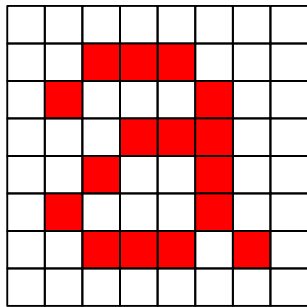
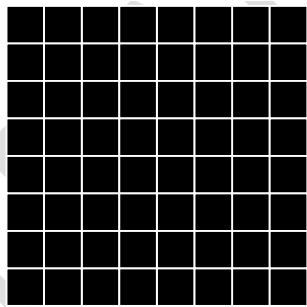
2200H		ALLPOFF																							
Inst/Para	R/W	Address		D15-8	D7	D6	D5	D4	D3	D2	D1	D0	HEX												
		MIPI	Other																						
ALLPOFF	W	22h	2200h	No Argument																					
Description	<p>This command turns the display panel black in Sleep Out mode and a status of the Display On/Off register can be on or off. This command does not change any other status.</p> <div style="display: flex; justify-content: space-around; align-items: center;"> <div style="text-align: center;"> <p>Input Image</p>  </div> <div style="font-size: 2em;">→</div> <div style="text-align: center;"> <p>Display Panel</p>  </div> </div> <p>“All Pixels On”, “Normal Display Mode On” or “Partial Mode On” commands are used to leave this mode. The display panel is showing the content of the Input Image after “Normal Display On” and “Partial Mode On” commands.</p>																								
	Restriction	-																							
Register Availability	<table border="1" style="width: 100%; border-collapse: collapse;"> <thead> <tr> <th>Status</th> <th>Availability</th> </tr> </thead> <tbody> <tr> <td>Normal Mode On, Idle Mode Off, Sleep Out</td> <td>Yes</td> </tr> <tr> <td>Normal Mode On, Idle Mode On, Sleep Out</td> <td>Yes</td> </tr> <tr> <td>Partial Mode On, Idle Mode Off, Sleep Out</td> <td>Yes</td> </tr> <tr> <td>Partial Mode On, Idle Mode On, Sleep Out</td> <td>Yes</td> </tr> <tr> <td>Sleep In</td> <td>Yes</td> </tr> </tbody> </table>													Status	Availability	Normal Mode On, Idle Mode Off, Sleep Out	Yes	Normal Mode On, Idle Mode On, Sleep Out	Yes	Partial Mode On, Idle Mode Off, Sleep Out	Yes	Partial Mode On, Idle Mode On, Sleep Out	Yes	Sleep In	Yes
Status	Availability																								
Normal Mode On, Idle Mode Off, Sleep Out	Yes																								
Normal Mode On, Idle Mode On, Sleep Out	Yes																								
Partial Mode On, Idle Mode Off, Sleep Out	Yes																								
Partial Mode On, Idle Mode On, Sleep Out	Yes																								
Sleep In	Yes																								
Default	<table border="1" style="width: 100%; border-collapse: collapse;"> <thead> <tr> <th>Status</th> <th>Default Value</th> </tr> </thead> <tbody> <tr> <td>Power On Sequence</td> <td>Display Inversion off</td> </tr> <tr> <td>SW Reset</td> <td>Display Inversion off</td> </tr> <tr> <td>HW Reset</td> <td>Display Inversion off</td> </tr> </tbody> </table>													Status	Default Value	Power On Sequence	Display Inversion off	SW Reset	Display Inversion off	HW Reset	Display Inversion off				
Status	Default Value																								
Power On Sequence	Display Inversion off																								
SW Reset	Display Inversion off																								
HW Reset	Display Inversion off																								

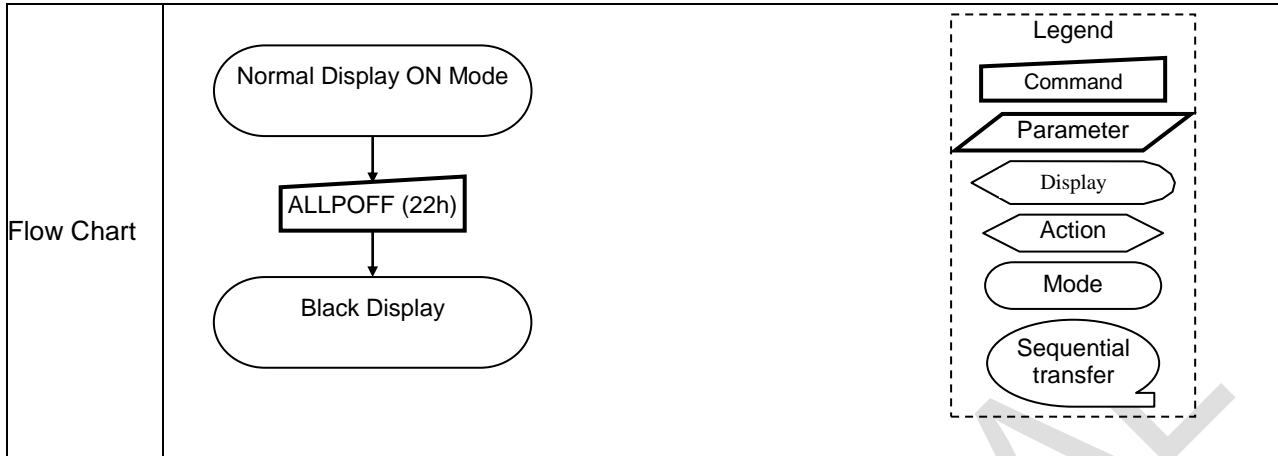

CONFIDENTIAL

ALLPON (2300H): All Pixel On

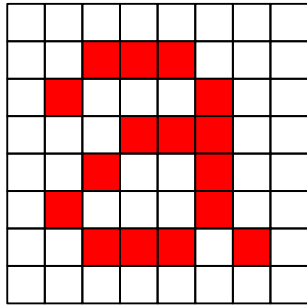
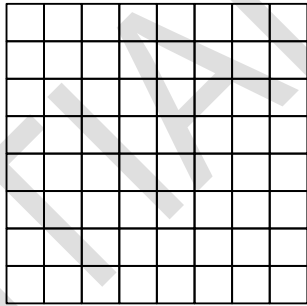
2300H		ALLPON																							
Inst/Para	R/W	Address		D15-8	D7	D6	D5	D4	D3	D2	D1	D0	HEX												
		MIPI	Other																						
ALLPON	W	23h	2300h	No Argument																					
Description	<p>This command turns the display panel white in Sleep Out mode and a status of the Display On/Off register can be on or off. This command does not change any other status.</p> <div style="display: flex; justify-content: space-around; align-items: center;"> <div style="text-align: center;"> <p>Input Image</p>  </div> <div style="font-size: 2em;">→</div> <div style="text-align: center;"> <p>Display Panel</p>  </div> </div> <p>“All Pixels Off”, “Normal Display Mode On” or “Partial Mode On” commands are used to leave this mode. The display panel is showing the content of the Input Image after “Normal Display On” and “Partial Mode On” commands.</p>																								
	Restriction	-																							
Register Availability	<table border="1" style="width: 100%; border-collapse: collapse;"> <thead> <tr> <th>Status</th> <th>Availability</th> </tr> </thead> <tbody> <tr> <td>Normal Mode On, Idle Mode Off, Sleep Out</td> <td>Yes</td> </tr> <tr> <td>Normal Mode On, Idle Mode On, Sleep Out</td> <td>Yes</td> </tr> <tr> <td>Partial Mode On, Idle Mode Off, Sleep Out</td> <td>Yes</td> </tr> <tr> <td>Partial Mode On, Idle Mode On, Sleep Out</td> <td>Yes</td> </tr> <tr> <td>Sleep In</td> <td>Yes</td> </tr> </tbody> </table>													Status	Availability	Normal Mode On, Idle Mode Off, Sleep Out	Yes	Normal Mode On, Idle Mode On, Sleep Out	Yes	Partial Mode On, Idle Mode Off, Sleep Out	Yes	Partial Mode On, Idle Mode On, Sleep Out	Yes	Sleep In	Yes
	Status	Availability																							
Normal Mode On, Idle Mode Off, Sleep Out	Yes																								
Normal Mode On, Idle Mode On, Sleep Out	Yes																								
Partial Mode On, Idle Mode Off, Sleep Out	Yes																								
Partial Mode On, Idle Mode On, Sleep Out	Yes																								
Sleep In	Yes																								
Default	<table border="1" style="width: 100%; border-collapse: collapse;"> <thead> <tr> <th>Status</th> <th>Default Value</th> </tr> </thead> <tbody> <tr> <td>Power On Sequence</td> <td>Display Inversion off</td> </tr> <tr> <td>SW Reset</td> <td>Display Inversion off</td> </tr> <tr> <td>HW Reset</td> <td>Display Inversion off</td> </tr> </tbody> </table>													Status	Default Value	Power On Sequence	Display Inversion off	SW Reset	Display Inversion off	HW Reset	Display Inversion off				
Status	Default Value																								
Power On Sequence	Display Inversion off																								
SW Reset	Display Inversion off																								
HW Reset	Display Inversion off																								

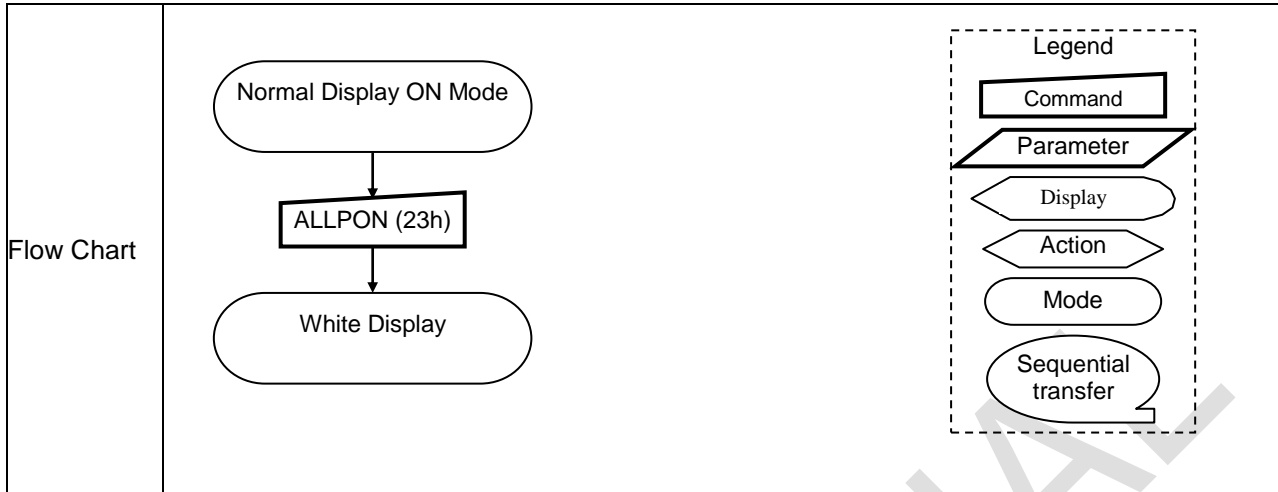

CONFIDENTIAL

DISPOFF (2800h): Display Off

2800H		DISPOFF (Display Off)																							
Inst/Para	R/W	Address		D15-8	D7	D6	D5	D4	D3	D2	D1	D0	HEX												
		MIPI	Other																						
DISPOFF	W	28h	2800h	No Argument																					
Description	<p>This command causes the display module to stop displaying the image data on the display device. No status bits are changed.</p> <div style="display: flex; justify-content: space-around; align-items: center;"> <div style="text-align: center;"> <p>Input Image</p> </div> <div style="font-size: 2em; margin: 0 20px;">→</div> <div style="text-align: center;"> <p>Display Panel</p> </div> </div>																								
Restriction	This command has no effect when module is already in display off mode.																								
Register Availability	<table border="1" style="width: 100%; border-collapse: collapse;"> <thead> <tr> <th>Status</th> <th>Availability</th> </tr> </thead> <tbody> <tr> <td>Normal Mode On, Idle Mode Off, Sleep Out</td> <td>Yes</td> </tr> <tr> <td>Normal Mode On, Idle Mode On, Sleep Out</td> <td>Yes</td> </tr> <tr> <td>Partial Mode On, Idle Mode Off, Sleep Out</td> <td>Yes</td> </tr> <tr> <td>Partial Mode On, Idle Mode On, Sleep Out</td> <td>Yes</td> </tr> <tr> <td>Sleep In</td> <td>Yes</td> </tr> </tbody> </table>													Status	Availability	Normal Mode On, Idle Mode Off, Sleep Out	Yes	Normal Mode On, Idle Mode On, Sleep Out	Yes	Partial Mode On, Idle Mode Off, Sleep Out	Yes	Partial Mode On, Idle Mode On, Sleep Out	Yes	Sleep In	Yes
Status	Availability																								
Normal Mode On, Idle Mode Off, Sleep Out	Yes																								
Normal Mode On, Idle Mode On, Sleep Out	Yes																								
Partial Mode On, Idle Mode Off, Sleep Out	Yes																								
Partial Mode On, Idle Mode On, Sleep Out	Yes																								
Sleep In	Yes																								
Default	<table border="1" style="width: 100%; border-collapse: collapse;"> <thead> <tr> <th>Status</th> <th>Default Value</th> </tr> </thead> <tbody> <tr> <td>Power On Sequence</td> <td>Display Off</td> </tr> <tr> <td>SW Reset</td> <td>Display Off</td> </tr> <tr> <td>HW Reset</td> <td>Display Off</td> </tr> </tbody> </table>													Status	Default Value	Power On Sequence	Display Off	SW Reset	Display Off	HW Reset	Display Off				
Status	Default Value																								
Power On Sequence	Display Off																								
SW Reset	Display Off																								
HW Reset	Display Off																								
Flow Chart	<div style="display: flex; align-items: center;"> <div style="flex: 1;"> <pre> graph TD A([Display On Mode]) --> B[DISPOFF (28h)] B --> C([Display OFF Mode]) </pre> </div> <div style="flex: 0.5; border: 1px dashed black; padding: 5px;"> <p>Legend</p> <ul style="list-style-type: none"> Command: Parameter: Display: Action: Mode: Sequential transfer: </div> </div>																								

DISPON (2900h): Display On

2900H		DISPON (Display On)																							
Inst/Para	R/W	Address		D15-8	D7	D6	D5	D4	D3	D2	D1	D0	HEX												
		MIPI	Other																						
DISPON	W	29h	2900h	No Argument																					
Description	<p>This command causes the display module to start displaying the image data on the display device. No status bits are changed.</p> <div style="display: flex; justify-content: space-around; align-items: center;"> <div style="text-align: center;"> <p>Input Image</p> </div> <div style="font-size: 2em;">→</div> <div style="text-align: center;"> <p>Display Panel</p> </div> </div>																								
Restriction	This command has no effect when module is already in display on mode.																								
Register Availability	<table border="1" style="width: 100%; border-collapse: collapse;"> <thead> <tr> <th>Status</th> <th>Availability</th> </tr> </thead> <tbody> <tr> <td>Normal Mode On, Idle Mode Off, Sleep Out</td> <td>Yes</td> </tr> <tr> <td>Normal Mode On, Idle Mode On, Sleep Out</td> <td>Yes</td> </tr> <tr> <td>Partial Mode On, Idle Mode Off, Sleep Out</td> <td>Yes</td> </tr> <tr> <td>Partial Mode On, Idle Mode On, Sleep Out</td> <td>Yes</td> </tr> <tr> <td>Sleep In</td> <td>Yes</td> </tr> </tbody> </table>													Status	Availability	Normal Mode On, Idle Mode Off, Sleep Out	Yes	Normal Mode On, Idle Mode On, Sleep Out	Yes	Partial Mode On, Idle Mode Off, Sleep Out	Yes	Partial Mode On, Idle Mode On, Sleep Out	Yes	Sleep In	Yes
Status	Availability																								
Normal Mode On, Idle Mode Off, Sleep Out	Yes																								
Normal Mode On, Idle Mode On, Sleep Out	Yes																								
Partial Mode On, Idle Mode Off, Sleep Out	Yes																								
Partial Mode On, Idle Mode On, Sleep Out	Yes																								
Sleep In	Yes																								
Default	<table border="1" style="width: 100%; border-collapse: collapse;"> <thead> <tr> <th>Status</th> <th>Default Value</th> </tr> </thead> <tbody> <tr> <td>Power On Sequence</td> <td>Display Off</td> </tr> <tr> <td>SW Reset</td> <td>Display Off</td> </tr> <tr> <td>HW Reset</td> <td>Display Off</td> </tr> </tbody> </table>													Status	Default Value	Power On Sequence	Display Off	SW Reset	Display Off	HW Reset	Display Off				
Status	Default Value																								
Power On Sequence	Display Off																								
SW Reset	Display Off																								
HW Reset	Display Off																								
Flow Chart	<div style="display: flex; align-items: center;"> <div style="flex: 1;"> <pre> graph TD A([Display OFF Mode]) --> B[DISPON (29h)] B --> C([Display ON Mode]) </pre> </div> <div style="flex: 1; border: 1px dashed black; padding: 5px;"> <p style="text-align: center;">Legend</p> <ul style="list-style-type: none"> Command: Parameter: Display: Action: Mode: Sequential transfer: </div> </div>																								

CASET(2A00h~2A03h) : Set Column Start Address

2A00H		CASET												
Inst/Para	R/W	Address		D15-8	D7	D6	D5	D4	D3	D2	D1	D0	HEX	
		MIPI	Other											
CASET	W	2Ah	2A00h	x	-	-	-	-	-	-	-	SC9	SC8	00
			2A01h	x	SC7	SC6	SC5	SC4	SC3	SC2	SC1	SC0	00	
			2A02h	x	-	-	-	-	-	-	-	EC9	EC8	01
			2A03h	x	EC7	EC6	EC5	EC4	EC3	EC2	EC1	EC0	8F	

This command defines the column extent of the frame memory accessed by the host processor with the read_memory_continue and write_memory_continue commands. This command makes no change on the other driver status. The values of SC[9:0] and EC[9:0] are referred when RAMWR command comes. Each value represents one column line in the Frame Memory.

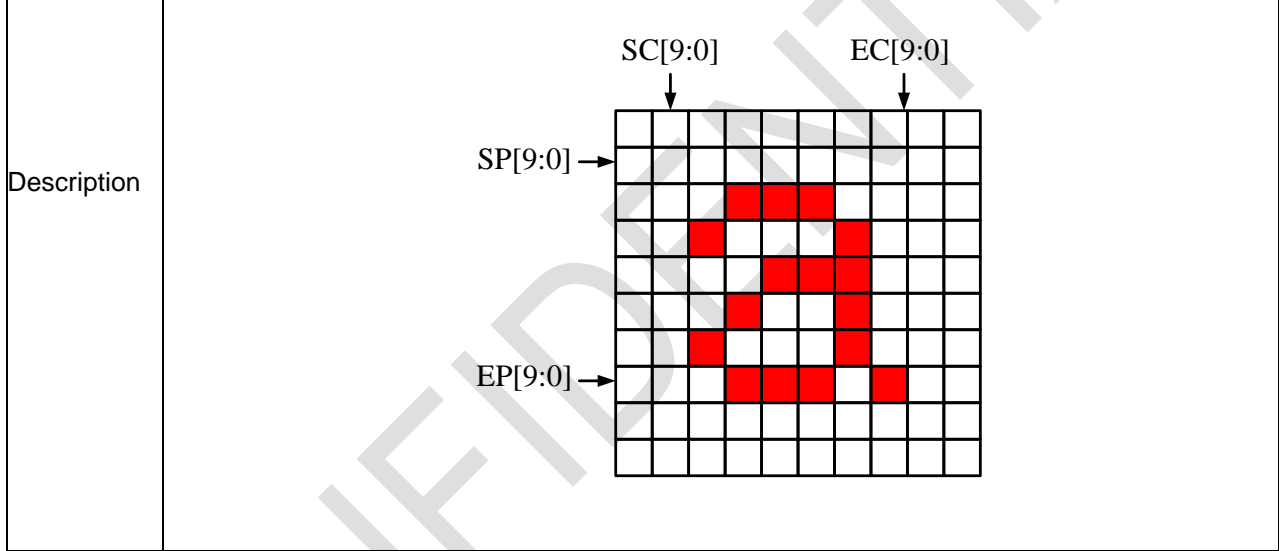

Restriction

(1) SC[9:0] always must be equal to or less than EC[9:0].
 (2) The SC[9:0] and EC[9:0]-SC[9:0]+1 must can be divisible by 2.

Register Availability

Status	Availability
Normal Mode On, Idle Mode Off, Sleep Out	Yes
Normal Mode On, Idle Mode On, Sleep Out	Yes
Partial Mode On, Idle Mode Off, Sleep Out	Yes
Partial Mode On, Idle Mode On, Sleep Out	Yes
Sleep In	Yes

Default	<table border="1"> <thead> <tr> <th rowspan="2">Status</th> <th colspan="2">Default Value</th> </tr> <tr> <th>SC[9:0]</th> <th>EC[9:0]</th> </tr> </thead> <tbody> <tr> <td>Power On Sequence</td> <td>0000h</td> <td>018Fh</td> </tr> <tr> <td>SW Reset</td> <td>0000h</td> <td>018Fh</td> </tr> <tr> <td>HW Reset</td> <td>0000h</td> <td>018Fh</td> </tr> </tbody> </table>		Status	Default Value		SC[9:0]	EC[9:0]	Power On Sequence	0000h	018Fh	SW Reset	0000h	018Fh	HW Reset	0000h	018Fh
	Status	Default Value														
		SC[9:0]	EC[9:0]													
	Power On Sequence	0000h	018Fh													
SW Reset	0000h	018Fh														
HW Reset	0000h	018Fh														
<p>Flow Chart</p> <pre> graph TD CASET[CASET 2Ah] --> P1[/1st & 2nd Parameter: SC[9:0] 3rd & 4th Parameter: EC[9:0]/] P1 --> RASET[RASET 2Bh] RASET --> P2[/1st & 2nd Parameter: SP[9:0] 3rd & 4th Parameter: EP[9:0]/] P2 --> RAMWR[RAMWR 2Ch] RAMWR --> ID([Image Data D1[B:0], D2[B:0], ..., Dn[B:0]]) ID --> AC[Any Command] </pre> <p>If Needed</p> <div style="border: 1px dashed black; padding: 5px;"> <p>Legend</p> <ul style="list-style-type: none"> Command Parameter Display Action Mode Sequential transfer </div>																

RASET(2B00h~2B03h) : Set Row Start Address

2B00H		RASET																							
Inst/Para	R/W	Address		D15-8	D7	D6	D5	D4	D3	D2	D1	D0	HEX												
		MIPI	Other																						
RASET	W	2Bh	2B00h	x	-	-	-	-	-	-	-	SP9	SP8	00											
			2B01h	x	SP7	SP6	SP5	SP4	SP3	SP2	SP1	SP0	00												
			2B02h	x	-	-	-	-	-	-	-	EP9	EP8	01											
			2B03h	x	EP7	EP6	EP5	EP4	EP3	EP2	EP1	EP0	8F												
Description	<p>This command defines the page extent of the frame memory accessed by the host processor with the write_memory_continue and read_memory_continue command. This command makes no change on the other driver status. The values of SP[9:0] and EP[9:0] are referred when RAMWR command comes. Each value represents one Page line in the Frame Memory.</p>																								
Restriction	<p>(1) SP[9:0] always must be equal to or less than EP[9:0] (2) The SP[9:0] and EP[9:0]-SP[9:0]+1 must can be divisible by 2.</p>																								
Register Availability	<table border="1"> <thead> <tr> <th>Status</th> <th>Availability</th> </tr> </thead> <tbody> <tr> <td>Normal Mode On, Idle Mode Off, Sleep Out</td> <td>Yes</td> </tr> <tr> <td>Normal Mode On, Idle Mode On, Sleep Out</td> <td>Yes</td> </tr> <tr> <td>Partial Mode On, Idle Mode Off, Sleep Out</td> <td>Yes</td> </tr> <tr> <td>Partial Mode On, Idle Mode On, Sleep Out</td> <td>Yes</td> </tr> <tr> <td>Sleep In</td> <td>Yes</td> </tr> </tbody> </table>													Status	Availability	Normal Mode On, Idle Mode Off, Sleep Out	Yes	Normal Mode On, Idle Mode On, Sleep Out	Yes	Partial Mode On, Idle Mode Off, Sleep Out	Yes	Partial Mode On, Idle Mode On, Sleep Out	Yes	Sleep In	Yes
Status	Availability																								
Normal Mode On, Idle Mode Off, Sleep Out	Yes																								
Normal Mode On, Idle Mode On, Sleep Out	Yes																								
Partial Mode On, Idle Mode Off, Sleep Out	Yes																								
Partial Mode On, Idle Mode On, Sleep Out	Yes																								
Sleep In	Yes																								

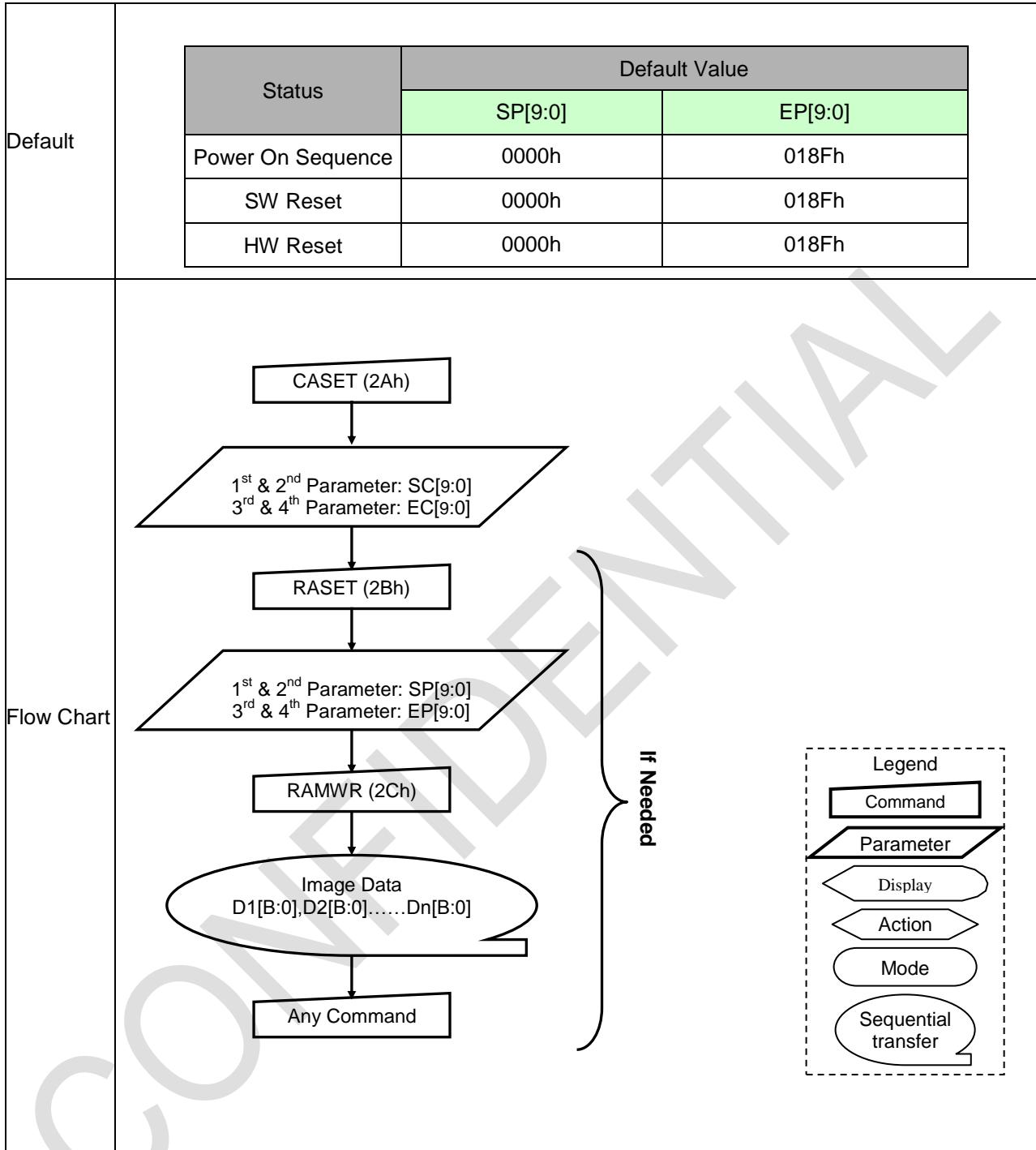

RAMWR (2C00h): Memory Write

2C00H		RAMWR																						
Inst/Para	R/W	Address		D15-8	D7	D6	D5	D4	D3	D2	D1	D0	HEX											
		MIPI	Other																					
RAMWR	W	2Ch	2C00h	X	0	0	1	0	1	1	0	0	2C											
			1 st Pixel	X	D ₇	D ₆	D ₅	D ₄	D ₃	D ₂	D ₁	D ₀												
			:	X	:	:	:	:	:	:	:	:	:											
			N th Pixel	X	D _{N7}	D _{N6}	D _{N5}	D _{N4}	D _{N3}	D _{N2}	D _{N1}	D _{N0}												
Description	<p>This command transfers image data from the host processor to the display module's frame memory starting at the pixel location specified by preceding CASET (2Ah) and RASET (2Bh) commands.</p>																							
Restriction	<p>A Memory Write should follow a CASET(2Ah), RASET(2Bh) or MADCTR(36h) to define the write location. Otherwise, data written with RAMWR(2Ch) and any following RAMWRC(3Ch) commands is written to undefined locations.</p>																							
Register Availability	<table border="1"> <thead> <tr> <th>Status</th> <th>Availability</th> </tr> </thead> <tbody> <tr> <td>Normal Mode On, Idle Mode Off, Sleep Out</td> <td>Yes</td> </tr> <tr> <td>Normal Mode On, Idle Mode On, Sleep Out</td> <td>Yes</td> </tr> <tr> <td>Partial Mode On, Idle Mode Off, Sleep Out</td> <td>Yes</td> </tr> <tr> <td>Partial Mode On, Idle Mode On, Sleep Out</td> <td>Yes</td> </tr> <tr> <td>Sleep In</td> <td>Yes</td> </tr> </tbody> </table>												Status	Availability	Normal Mode On, Idle Mode Off, Sleep Out	Yes	Normal Mode On, Idle Mode On, Sleep Out	Yes	Partial Mode On, Idle Mode Off, Sleep Out	Yes	Partial Mode On, Idle Mode On, Sleep Out	Yes	Sleep In	Yes
Status	Availability																							
Normal Mode On, Idle Mode Off, Sleep Out	Yes																							
Normal Mode On, Idle Mode On, Sleep Out	Yes																							
Partial Mode On, Idle Mode Off, Sleep Out	Yes																							
Partial Mode On, Idle Mode On, Sleep Out	Yes																							
Sleep In	Yes																							
Default	<table border="1"> <thead> <tr> <th>Status</th> <th>Default Value</th> </tr> </thead> <tbody> <tr> <td>Power On Sequence</td> <td>Contents of memory is set randomly</td> </tr> <tr> <td>SW Reset</td> <td>Contents of memory is not cleared</td> </tr> <tr> <td>HW Reset</td> <td>Contents of memory is not cleared</td> </tr> </tbody> </table>												Status	Default Value	Power On Sequence	Contents of memory is set randomly	SW Reset	Contents of memory is not cleared	HW Reset	Contents of memory is not cleared				
Status	Default Value																							
Power On Sequence	Contents of memory is set randomly																							
SW Reset	Contents of memory is not cleared																							
HW Reset	Contents of memory is not cleared																							

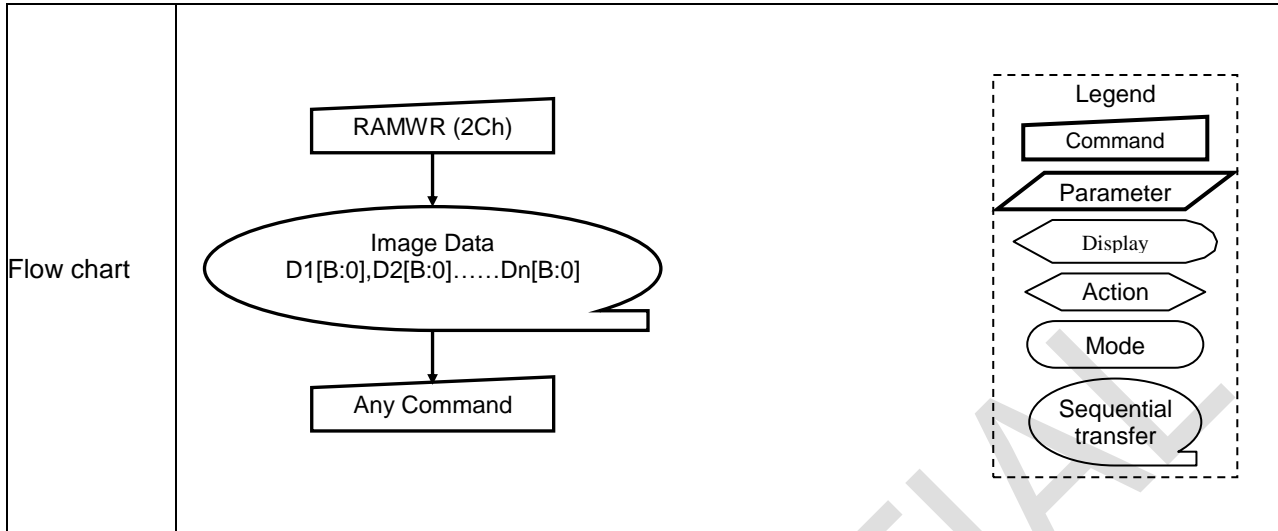

CONFIDENTIAL

PTLAR (3000h): Partial Area

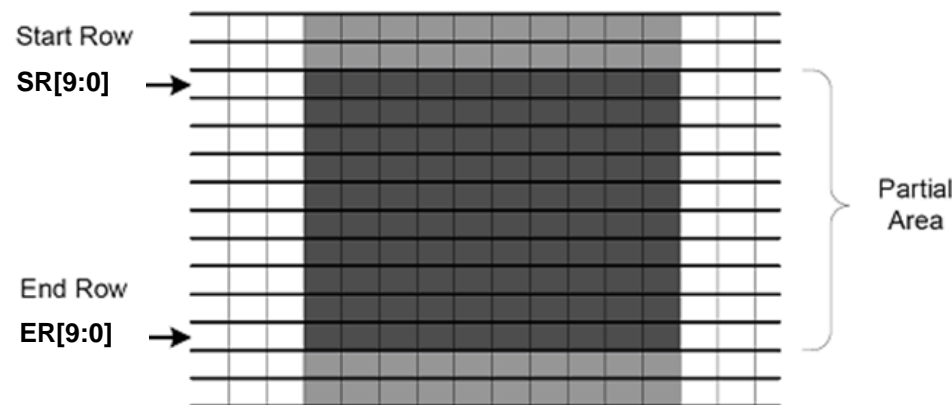
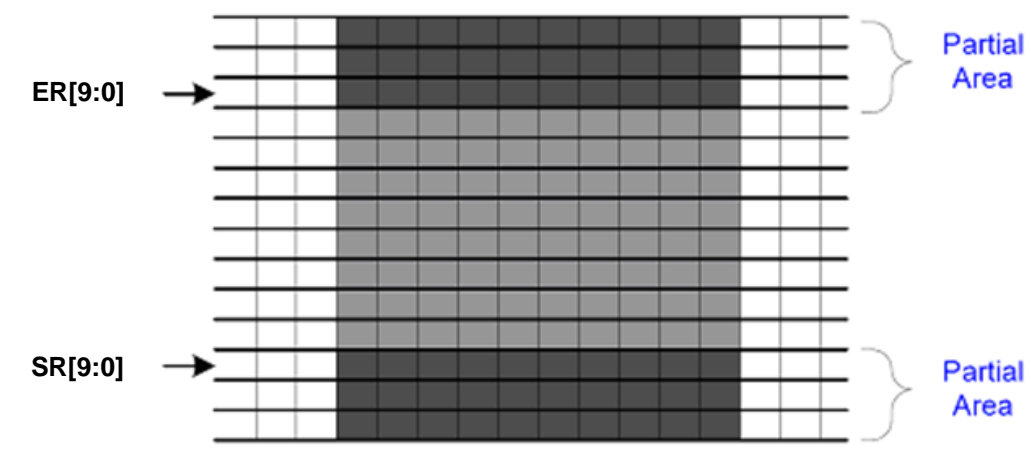
3000H		PTLAR (Partial Area)												
Inst/Para	R/W	Address		D15-8	D7	D6	D5	D4	D3	D2	D1	D0	HEX	
		MIPI	Other											
PTLAR	W	30h	3000h	x	-	-	-	-	-	-	-	SR9	SR8	00
			3001h	x	SR7	SR6	SR5	SR4	SR3	SR2	SR1	SR0	00	
			3002h	x	-	-	-	-	-	-	-	ER9	ER8	01
			3003h	x	ER7	ER6	ER5	ER4	ER3	ER2	ER1	ER0	8F	
Description	<p>This command defines the Partial Display mode's display area. There are two parameters associated with this command, the first defines the Start Row (SR) and the second the End Row (ER), as illustrated in the following figure.</p> <p>If End Row > Start Row</p>  <p>If End Row < Start Row</p>  <p>If End Row = Start Row then the Partial Area will be one row deep.</p>													
	Restriction	SR[9:0] and ER[9:0] settings should be within max available Display Area.												

Register Availability	<table border="1"> <thead> <tr> <th>Status</th> <th>Availability</th> </tr> </thead> <tbody> <tr> <td>Normal Mode On, Idle Mode Off, Sleep Out</td> <td>Yes</td> </tr> <tr> <td>Normal Mode On, Idle Mode On, Sleep Out</td> <td>Yes</td> </tr> <tr> <td>Partial Mode On, Idle Mode Off, Sleep Out</td> <td>Yes</td> </tr> <tr> <td>Partial Mode On, Idle Mode On, Sleep Out</td> <td>Yes</td> </tr> <tr> <td>Sleep In</td> <td>Yes</td> </tr> </tbody> </table>	Status	Availability	Normal Mode On, Idle Mode Off, Sleep Out	Yes	Normal Mode On, Idle Mode On, Sleep Out	Yes	Partial Mode On, Idle Mode Off, Sleep Out	Yes	Partial Mode On, Idle Mode On, Sleep Out	Yes	Sleep In	Yes		
Status	Availability														
Normal Mode On, Idle Mode Off, Sleep Out	Yes														
Normal Mode On, Idle Mode On, Sleep Out	Yes														
Partial Mode On, Idle Mode Off, Sleep Out	Yes														
Partial Mode On, Idle Mode On, Sleep Out	Yes														
Sleep In	Yes														
Default	<table border="1"> <thead> <tr> <th rowspan="2">Status</th> <th colspan="2">Default Value</th> </tr> <tr> <th>SR[9:0]</th> <th>ER[9:0]</th> </tr> </thead> <tbody> <tr> <td>Power On Sequence</td> <td>0000h</td> <td>018Fh</td> </tr> <tr> <td>SW Reset</td> <td>0000h</td> <td>018Fh</td> </tr> <tr> <td>HW Reset</td> <td>0000h</td> <td>018Fh</td> </tr> </tbody> </table>	Status	Default Value		SR[9:0]	ER[9:0]	Power On Sequence	0000h	018Fh	SW Reset	0000h	018Fh	HW Reset	0000h	018Fh
Status	Default Value														
	SR[9:0]	ER[9:0]													
Power On Sequence	0000h	018Fh													
SW Reset	0000h	018Fh													
HW Reset	0000h	018Fh													
Flow chart	<div style="display: flex; justify-content: space-around;"> <div style="width: 45%;"> <p>1. To Enter Partial Mode</p> <pre> graph TD A[PTLAR (30h)] --> B[/1st & 2nd Parameter: SR[9:0]/] B --> C[/3rd & 4th Parameter: ER[9:0]/] C --> D[PTLON (12h)] D --> E([Partial Mode]) </pre> </div> <div style="width: 45%;"> <p>2. To Exit Partial Mode</p> <pre> graph TD F([Partial Mode]) --> G[DISPOFF (28h)] G --> H[NORON (13h)] H --> I([Partial Mode OFF]) I --> J([Image Data D1[B:0], D2[B:0]... ...Dn[B:0]]) J --> K[DISON (29h)] </pre> </div> </div> <div style="margin-top: 20px;"> <p>Optional to prevent tearing effect image display</p> <pre> graph TD G -.-> L[Optional to prevent tearing effect image display] </pre> </div> <div style="margin-top: 20px;"> <p>Legend</p> <ul style="list-style-type: none"> Command Parameter Display Action Mode Sequential transfer </div> <p>Note : B=23</p>														

PTLAR (3100h): Vertical Partial Area

3000H		PTLAR (Partial Area)											
Inst/Para	R/W	Address		D15-8	D7	D6	D5	D4	D3	D2	D1	D0	HEX
		MIPI	Other										
PTLAR	W	30h	3100h	x	-	-	-	-	-	-	-	SC8	00
			3101h	x	SC7	SC6	SC5	SC4	SC3	SC2	SC1	SC0	00
			3102h	x	-	-	-	-	-	-	-	EC8	01
			3103h	x	EC7	EC6	EC5	EC4	EC3	EC2	EC1	EC0	8F

This command defines the Vertical Partial Display mode's display area. There are two parameters associated with this command, the first defines the Start Column (SC) and the second the End Column (EC), as illustrated in the following figure.

If End Column > Start Column

Start Column
SC[9:0]

↓

End Column
EC[9:0]

↓

Partial Area

If End Column < Start Column

Description

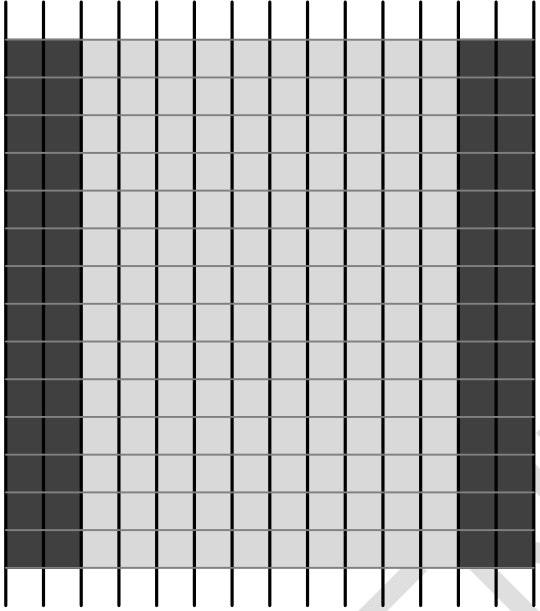
	<div style="text-align: center;"> <p>End Column EC[9:0]</p> <p>Start Column SC[9:0]</p>  <p>Partial Area Partial Area</p> <p>If End Column = Start Column then the Partial Area will be one column deep.</p> </div>												
Restriction	SC[9:0] and EC[9:0] settings should be within max available Display Area.												
Register Availability	<table border="1" style="width: 100%; border-collapse: collapse;"> <thead> <tr> <th style="text-align: left;">Status</th> <th style="text-align: left;">Availability</th> </tr> </thead> <tbody> <tr> <td>Normal Mode On, Idle Mode Off, Sleep Out</td> <td>Yes</td> </tr> <tr> <td>Normal Mode On, Idle Mode On, Sleep Out</td> <td>Yes</td> </tr> <tr> <td>Partial Mode On, Idle Mode Off, Sleep Out</td> <td>Yes</td> </tr> <tr> <td>Partial Mode On, Idle Mode On, Sleep Out</td> <td>Yes</td> </tr> <tr> <td>Sleep In</td> <td>Yes</td> </tr> </tbody> </table>	Status	Availability	Normal Mode On, Idle Mode Off, Sleep Out	Yes	Normal Mode On, Idle Mode On, Sleep Out	Yes	Partial Mode On, Idle Mode Off, Sleep Out	Yes	Partial Mode On, Idle Mode On, Sleep Out	Yes	Sleep In	Yes
Status	Availability												
Normal Mode On, Idle Mode Off, Sleep Out	Yes												
Normal Mode On, Idle Mode On, Sleep Out	Yes												
Partial Mode On, Idle Mode Off, Sleep Out	Yes												
Partial Mode On, Idle Mode On, Sleep Out	Yes												
Sleep In	Yes												

Default	<table border="1"> <thead> <tr> <th rowspan="2">Status</th> <th colspan="2">Default Value</th> </tr> <tr> <th>SC[9:0]</th> <th>EC[9:0]</th> </tr> </thead> <tbody> <tr> <td>Power On Sequence</td> <td>0000h</td> <td>018Fh</td> </tr> <tr> <td>SW Reset</td> <td>0000h</td> <td>018Fh</td> </tr> <tr> <td>HW Reset</td> <td>0000h</td> <td>018Fh</td> </tr> </tbody> </table>		Status	Default Value		SC[9:0]	EC[9:0]	Power On Sequence	0000h	018Fh	SW Reset	0000h	018Fh	HW Reset	0000h	018Fh
	Status	Default Value														
		SC[9:0]	EC[9:0]													
	Power On Sequence	0000h	018Fh													
	SW Reset	0000h	018Fh													
HW Reset	0000h	018Fh														
<p>Flow chart</p> <div style="display: flex; justify-content: space-around;"> <div style="width: 45%;"> <p>1. To Enter Partial Mode</p> <pre> graph TD A[PTLAR 30h] --> B[/1st & 2nd Parameter: SR[9:0]/] B --> C[/3rd & 4th Parameter: ER[9:0]/] C --> D[PTLON 12h] D --> E([Partial Mode]) </pre> </div> <div style="width: 45%;"> <p>2. To Exit Partial Mode</p> <pre> graph TD F([Partial Mode]) --> G[DISPOFF 28h] G --> H[NORON 13h] H --> I([Partial Mode OFF]) I --> J([Image Data D1[B:0], D2[B:0]... ...Dn[B:0]]) J --> K[DISON 29h] </pre> </div> </div> <div style="margin-top: 20px;"> <p>Optional to prevent tearing effect image display</p> <pre> graph TD L[Optional to prevent tearing effect image display] -.-> G </pre> </div> <div style="margin-top: 20px;"> <p>Legend</p> <ul style="list-style-type: none"> Command Parameter Display Action Mode Sequential transfer </div> <p>Note : B=23</p>																

TEOFF (3400h): Tearing Effect Line OFF

3400H		TEOFF (Tearing Effect Line OFF)																							
Inst/Para	R/W	Address		D15-8	D7	D6	D5	D4	D3	D2	D1	D0	HEX												
		MIPI	Other																						
TEOFF	W	34h	3400h	No Argument																					
Description	This command turns off the display module's Tearing Effect output signal on the TE signal line.																								
Restriction	This command has no effect when the Tearing Effect output is already off.																								
Register Availability	<table border="1"> <thead> <tr> <th>Status</th> <th>Availability</th> </tr> </thead> <tbody> <tr> <td>Normal Mode On, Idle Mode Off, Sleep Out</td> <td>Yes</td> </tr> <tr> <td>Normal Mode On, Idle Mode On, Sleep Out</td> <td>Yes</td> </tr> <tr> <td>Partial Mode On, Idle Mode Off, Sleep Out</td> <td>Yes</td> </tr> <tr> <td>Partial Mode On, Idle Mode On, Sleep Out</td> <td>Yes</td> </tr> <tr> <td>Sleep In</td> <td>Yes</td> </tr> </tbody> </table>													Status	Availability	Normal Mode On, Idle Mode Off, Sleep Out	Yes	Normal Mode On, Idle Mode On, Sleep Out	Yes	Partial Mode On, Idle Mode Off, Sleep Out	Yes	Partial Mode On, Idle Mode On, Sleep Out	Yes	Sleep In	Yes
Status	Availability																								
Normal Mode On, Idle Mode Off, Sleep Out	Yes																								
Normal Mode On, Idle Mode On, Sleep Out	Yes																								
Partial Mode On, Idle Mode Off, Sleep Out	Yes																								
Partial Mode On, Idle Mode On, Sleep Out	Yes																								
Sleep In	Yes																								
Default	<table border="1"> <thead> <tr> <th>Status</th> <th>Default Value</th> </tr> </thead> <tbody> <tr> <td>Power On Sequence</td> <td>OFF</td> </tr> <tr> <td>SW Reset</td> <td>OFF</td> </tr> <tr> <td>HW Reset</td> <td>OFF</td> </tr> </tbody> </table>													Status	Default Value	Power On Sequence	OFF	SW Reset	OFF	HW Reset	OFF				
Status	Default Value																								
Power On Sequence	OFF																								
SW Reset	OFF																								
HW Reset	OFF																								
Flow Chart	<pre> graph TD A([TE Line Output ON]) --> B[TEOFF (34h)] B --> C([TE Line Output OFF]) </pre> <p>Legend</p> <ul style="list-style-type: none"> Command: Rectangle Parameter: Parallelogram Display: Oval Action: Arrow Mode: Rounded Rectangle Sequential transfer: Speech bubble 																								

TEON (3500h): Tearing Effect Line ON

3500H		TEON (Tearing Effect Line ON)												
Inst/Para	R/W	Address		D15-8	D7	D6	D5	D4	D3	D2	D1	D0	HEX	
		MIPI	Other											
TEON	W	35h	3500h	x	0	0	0	0	0	0	0]	TE_M	TELOM	00

Bit	Symbol	Description	Comment
D1	TE_M	Output mode of TE signal set	1: Refresh frame active <Note> TE output active at refresh frame to avoid tearing effect, command can be set: 1. 0x3500=00.or 2. 0x3500=02.
D0	TELOM	Output mode of TE signal	0:only V-blanking 1:V-blanking +H-blanking

Description

This command turns on the tearing Effect output signal on the TE signal line. The TE signal is not affected by changing MADCTR (36h) B4 (Line Address Order).
The Tearing Effect Line On has one parameter that describes the Tearing Effect Output Line mode.

If TELOM = 0:

The Tearing Effect Output line consists of V-Blanking information only.

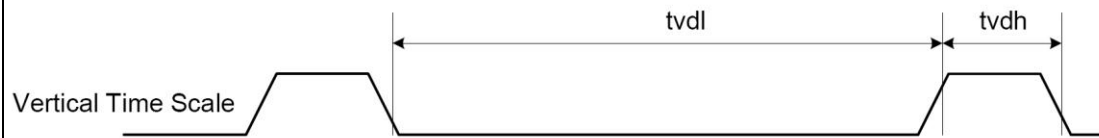

If TELOM = 1:

The Tearing Effect Output Line consists of both V-Blanking and H-Blanking information.



The Tearing Effect Output line shall be active low when the display module is in Sleep mode.

Restriction	This command has no effect when Tearing Effect output is already ON.												
Register Availability	<table border="1"> <thead> <tr> <th>Status</th> <th>Availability</th> </tr> </thead> <tbody> <tr> <td>Normal Mode On, Idle Mode Off, Sleep Out</td> <td>Yes</td> </tr> <tr> <td>Normal Mode On, Idle Mode On, Sleep Out</td> <td>Yes</td> </tr> <tr> <td>Partial Mode On, Idle Mode Off, Sleep Out</td> <td>Yes</td> </tr> <tr> <td>Partial Mode On, Idle Mode On, Sleep Out</td> <td>Yes</td> </tr> <tr> <td>Sleep In</td> <td>Yes</td> </tr> </tbody> </table>	Status	Availability	Normal Mode On, Idle Mode Off, Sleep Out	Yes	Normal Mode On, Idle Mode On, Sleep Out	Yes	Partial Mode On, Idle Mode Off, Sleep Out	Yes	Partial Mode On, Idle Mode On, Sleep Out	Yes	Sleep In	Yes
Status	Availability												
Normal Mode On, Idle Mode Off, Sleep Out	Yes												
Normal Mode On, Idle Mode On, Sleep Out	Yes												
Partial Mode On, Idle Mode Off, Sleep Out	Yes												
Partial Mode On, Idle Mode On, Sleep Out	Yes												
Sleep In	Yes												
Default	<table border="1"> <thead> <tr> <th>Status</th> <th>Default Value</th> </tr> </thead> <tbody> <tr> <td>Power On Sequence</td> <td>OFF</td> </tr> <tr> <td>SW Reset</td> <td>OFF</td> </tr> <tr> <td>HW Reset</td> <td>OFF</td> </tr> </tbody> </table>	Status	Default Value	Power On Sequence	OFF	SW Reset	OFF	HW Reset	OFF				
Status	Default Value												
Power On Sequence	OFF												
SW Reset	OFF												
HW Reset	OFF												

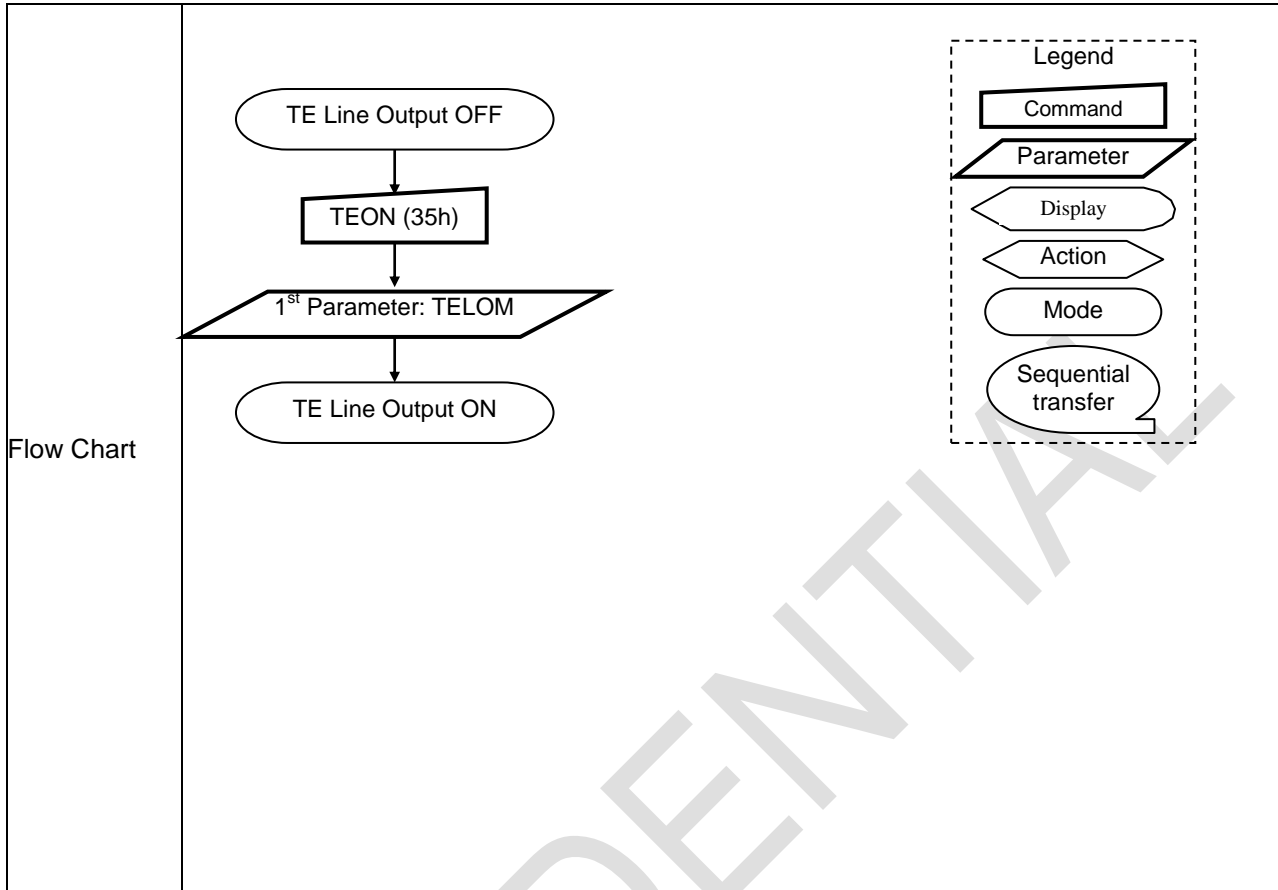

CONFIDENTIAL

MADCTR (3600h): Scan Direction Control

3600H		MADCTR (Scan Direction Control)																																							
Inst/Para	R/W	Address		D15-8	D7	D6	D5	D4	D3	D2	D1	D0	HEX																												
		MIPI	Other																																						
MADCTR	W	36h	3600h	x	D7	D6	D5	D4	D3	D2	D1	D0	00																												
Description	<p>This command defines the scan direction of Source and Gate Driver. This command makes no change on the other driver status.</p> <table border="1"> <thead> <tr> <th>Bit</th> <th>Symbol</th> <th>Description</th> <th>Comment</th> </tr> </thead> <tbody> <tr> <td>D7</td> <td>Reserved</td> <td></td> <td></td> </tr> <tr> <td>D6</td> <td>MX</td> <td>Column Address Increment</td> <td>0: Increasing in horizontal 1: Decreasing in horizontal</td> </tr> <tr> <td>D3</td> <td>RGB</td> <td>RGB/BGR Order</td> <td>'1' =BGR, "0"=RGB</td> </tr> <tr> <td>D2</td> <td>Reserved</td> <td></td> <td></td> </tr> <tr> <td>D1</td> <td>Reserved</td> <td></td> <td></td> </tr> <tr> <td>D0</td> <td>Reserved</td> <td></td> <td></td> </tr> </tbody> </table>													Bit	Symbol	Description	Comment	D7	Reserved			D6	MX	Column Address Increment	0: Increasing in horizontal 1: Decreasing in horizontal	D3	RGB	RGB/BGR Order	'1' =BGR, "0"=RGB	D2	Reserved			D1	Reserved			D0	Reserved		
	Bit	Symbol	Description	Comment																																					
D7	Reserved																																								
D6	MX	Column Address Increment	0: Increasing in horizontal 1: Decreasing in horizontal																																						
D3	RGB	RGB/BGR Order	'1' =BGR, "0"=RGB																																						
D2	Reserved																																								
D1	Reserved																																								
D0	Reserved																																								
	<p>D3=0</p> <p>Input Image: RGB (R, G, B) → Sent RGB → Display Panel: RGB (R, G, B)</p> <p>D3=1</p> <p>Input Image: RGB (R, G, B) → Sent BGR → Display Panel: BGR (B, G, R)</p>																																								
Restriction																																									
Register Availability	<table border="1"> <thead> <tr> <th>Status</th> <th>Availability</th> </tr> </thead> <tbody> <tr> <td>Normal Mode On, Idle Mode Off, Sleep Out</td> <td>Yes</td> </tr> <tr> <td>Normal Mode On, Idle Mode On, Sleep Out</td> <td>Yes</td> </tr> <tr> <td>Partial Mode On, Idle Mode Off, Sleep Out</td> <td>Yes</td> </tr> <tr> <td>Partial Mode On, Idle Mode On, Sleep Out</td> <td>Yes</td> </tr> <tr> <td>Sleep In</td> <td>Yes</td> </tr> </tbody> </table>													Status	Availability	Normal Mode On, Idle Mode Off, Sleep Out	Yes	Normal Mode On, Idle Mode On, Sleep Out	Yes	Partial Mode On, Idle Mode Off, Sleep Out	Yes	Partial Mode On, Idle Mode On, Sleep Out	Yes	Sleep In	Yes																
Status	Availability																																								
Normal Mode On, Idle Mode Off, Sleep Out	Yes																																								
Normal Mode On, Idle Mode On, Sleep Out	Yes																																								
Partial Mode On, Idle Mode Off, Sleep Out	Yes																																								
Partial Mode On, Idle Mode On, Sleep Out	Yes																																								
Sleep In	Yes																																								

Default	<table border="1"> <thead> <tr> <th>Status</th> <th>Default Value</th> </tr> </thead> <tbody> <tr> <td>Power On Sequence</td> <td>00h</td> </tr> <tr> <td>SW Reset</td> <td>00h</td> </tr> <tr> <td>HW Reset</td> <td>00h</td> </tr> </tbody> </table>	Status	Default Value	Power On Sequence	00h	SW Reset	00h	HW Reset	00h
Status	Default Value								
Power On Sequence	00h								
SW Reset	00h								
HW Reset	00h								
Flow chart	<p>The flow chart shows a rectangular box labeled 'MADCTR (36h)' with a downward arrow pointing to a parallelogram box labeled '1st Parameter'. To the right is a legend box containing six symbols: a rectangle for 'Command', a parallelogram for 'Parameter', an oval for 'Display', an arrow for 'Action', a rounded rectangle for 'Mode', and an oval with a tail for 'Sequential transfer'.</p>								

CONFIDENTIAL

IDMOFF (3800h): Idle Mode Off

3800H		IDMOFF (Idle Mode Off)																			
Inst/Para	R/W	Address		D15-8	D7	D6	D5	D4	D3	D2	D1	D0	HEX								
		MIPI	Other																		
IDMOFF	W	38h	3800h	No Argument																	
Description	This command causes the display module to exit Idle mode.																				
Restriction	This command has no effect when the display module is not in Idle mode.																				
Register Availability	<table border="1"> <thead> <tr> <th>Status</th> <th>Availability</th> </tr> </thead> <tbody> <tr> <td>Normal Mode On, Idle Mode On</td> <td>Yes</td> </tr> <tr> <td>Partial Mode On, Idle Mode On</td> <td>Yes</td> </tr> <tr> <td>Sleep Out, Sleep In</td> <td>No</td> </tr> </tbody> </table>													Status	Availability	Normal Mode On, Idle Mode On	Yes	Partial Mode On, Idle Mode On	Yes	Sleep Out, Sleep In	No
Status	Availability																				
Normal Mode On, Idle Mode On	Yes																				
Partial Mode On, Idle Mode On	Yes																				
Sleep Out, Sleep In	No																				
Default	<table border="1"> <thead> <tr> <th>Status</th> <th>Default Value</th> </tr> </thead> <tbody> <tr> <td>Power On Sequence</td> <td>Idle Mode Off</td> </tr> <tr> <td>SW Reset</td> <td>Idle Mode Off</td> </tr> <tr> <td>HW Reset</td> <td>Idle Mode Off</td> </tr> </tbody> </table>													Status	Default Value	Power On Sequence	Idle Mode Off	SW Reset	Idle Mode Off	HW Reset	Idle Mode Off
Status	Default Value																				
Power On Sequence	Idle Mode Off																				
SW Reset	Idle Mode Off																				
HW Reset	Idle Mode Off																				
Flow Chart	<pre> graph TD A[Idle mode ON] --> B[IDMOFF (38h)] B --> C[Idle mode OFF] </pre> <p>Legend</p> <ul style="list-style-type: none"> Command: Rectangle Parameter: Parallelogram Display: Display icon Action: Arrow Mode: Oval Sequential transfer: Oval with tail 																				

IDMON (3900h): Enter_idle_mode

3900H	Enter_idle_mode																																			
Inst/Para	R/W	Address		D15-8	D7	D6	D5	D4	D3	D2	D1	D0	HEX																							
		MIPI	Other																																	
IDMON	W	39h	3900h	No Argument																																
Description	<p>This command causes the display module to enter Idle Mode. In Idle Mode, color expression is reduced. Colors are shown on the display device using the MSB of each of the R, G and B color components in the Input Image.</p> <div style="display: flex; justify-content: space-around; align-items: center;"> <div style="text-align: center;"> <p>Input Image</p> </div> <div style="font-size: 2em; margin: 0 20px;">→</div> <div style="text-align: center;"> <p>Panel Display</p> </div> </div>																																			
	<table border="1" style="width: 100%; border-collapse: collapse;"> <thead> <tr> <th>Color</th> <th>R7 R6 R5 R4 R3 R2 R1 R0</th> <th>G7 G6 G5 G4 G3 G2 G1 G0</th> <th>B7 B6 B5 B4 B3 B2 B1 B0</th> </tr> </thead> <tbody> <tr> <td>Black</td> <td>0XXXXXXXX</td> <td>0XXXXXXXX</td> <td>0XXXXXXXX</td> </tr> <tr> <td>Blue</td> <td>0XXXXXXXX</td> <td>0XXXXXXXX</td> <td>1XXXXXXXX</td> </tr> <tr> <td>Red</td> <td>1XXXXXXXX</td> <td>0XXXXXXXX</td> <td>0XXXXXXXX</td> </tr> <tr> <td>Magenta</td> <td>1XXXXXXXX</td> <td>0XXXXXXXX</td> <td>1XXXXXXXX</td> </tr> <tr> <td>Green</td> <td>0XXXXXXXX</td> <td>1XXXXXXXX</td> <td>0XXXXXXXX</td> </tr> <tr> <td>Cyan</td> <td>0XXXXXXXX</td> <td>1XXXXXXXX</td> <td>1XXXXXXXX</td> </tr> <tr> <td>Yellow</td> <td>1XXXXXXXX</td> <td>1XXXXXXXX</td> <td>0XXXXXXXX</td> </tr> <tr> <td>White</td> <td>1XXXXXXXX</td> <td>1XXXXXXXX</td> <td>1XXXXXXXX</td> </tr> </tbody> </table>	Color	R7 R6 R5 R4 R3 R2 R1 R0	G7 G6 G5 G4 G3 G2 G1 G0	B7 B6 B5 B4 B3 B2 B1 B0	Black	0XXXXXXXX	0XXXXXXXX	0XXXXXXXX	Blue	0XXXXXXXX	0XXXXXXXX	1XXXXXXXX	Red	1XXXXXXXX	0XXXXXXXX	0XXXXXXXX	Magenta	1XXXXXXXX	0XXXXXXXX	1XXXXXXXX	Green	0XXXXXXXX	1XXXXXXXX	0XXXXXXXX	Cyan	0XXXXXXXX	1XXXXXXXX	1XXXXXXXX	Yellow	1XXXXXXXX	1XXXXXXXX	0XXXXXXXX	White	1XXXXXXXX	1XXXXXXXX
Color	R7 R6 R5 R4 R3 R2 R1 R0	G7 G6 G5 G4 G3 G2 G1 G0	B7 B6 B5 B4 B3 B2 B1 B0																																	
Black	0XXXXXXXX	0XXXXXXXX	0XXXXXXXX																																	
Blue	0XXXXXXXX	0XXXXXXXX	1XXXXXXXX																																	
Red	1XXXXXXXX	0XXXXXXXX	0XXXXXXXX																																	
Magenta	1XXXXXXXX	0XXXXXXXX	1XXXXXXXX																																	
Green	0XXXXXXXX	1XXXXXXXX	0XXXXXXXX																																	
Cyan	0XXXXXXXX	1XXXXXXXX	1XXXXXXXX																																	
Yellow	1XXXXXXXX	1XXXXXXXX	0XXXXXXXX																																	
White	1XXXXXXXX	1XXXXXXXX	1XXXXXXXX																																	
Restriction	This command has no effect when module is already in idle on mode.																																			
Register Availability	<table border="1" style="width: 100%; border-collapse: collapse;"> <thead> <tr> <th>Status</th> <th>Availability</th> </tr> </thead> <tbody> <tr> <td>Normal Mode On, Idle Mode Off</td> <td>Yes</td> </tr> <tr> <td>Partial Mode On, Idle Mode Off</td> <td>Yes</td> </tr> <tr> <td>Sleep out, Sleep In</td> <td>No</td> </tr> </tbody> </table>													Status	Availability	Normal Mode On, Idle Mode Off	Yes	Partial Mode On, Idle Mode Off	Yes	Sleep out, Sleep In	No															
Status	Availability																																			
Normal Mode On, Idle Mode Off	Yes																																			
Partial Mode On, Idle Mode Off	Yes																																			
Sleep out, Sleep In	No																																			
Default	<table border="1" style="width: 100%; border-collapse: collapse;"> <thead> <tr> <th>Status</th> <th>Default Value</th> </tr> </thead> <tbody> <tr> <td>Power On Sequence</td> <td>Idle Mode Off</td> </tr> <tr> <td>SW Reset</td> <td>Idle Mode Off</td> </tr> <tr> <td>HW Reset</td> <td>Idle Mode Off</td> </tr> </tbody> </table>													Status	Default Value	Power On Sequence	Idle Mode Off	SW Reset	Idle Mode Off	HW Reset	Idle Mode Off															
Status	Default Value																																			
Power On Sequence	Idle Mode Off																																			
SW Reset	Idle Mode Off																																			
HW Reset	Idle Mode Off																																			

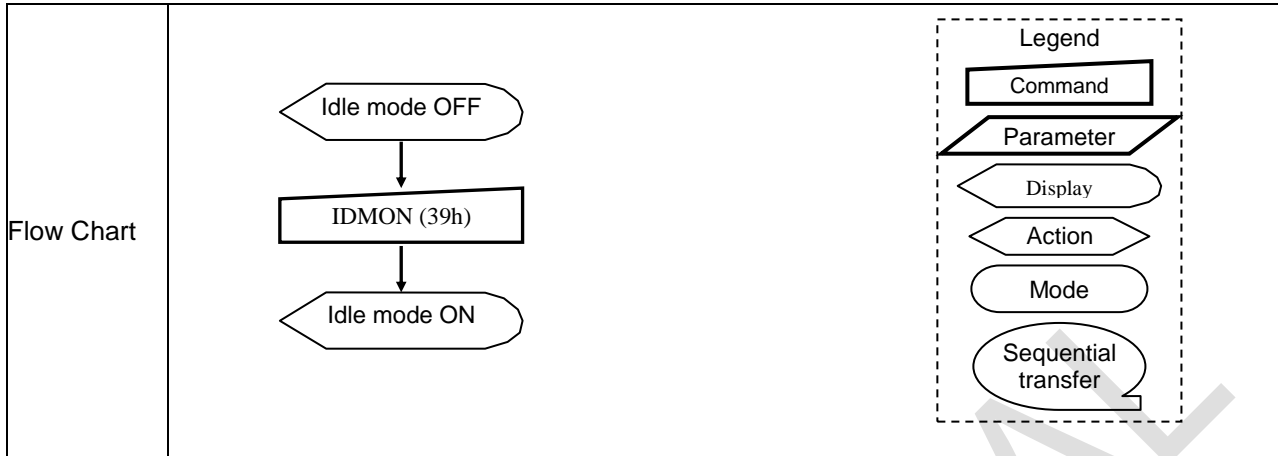

CONFIDENTIAL

COLMOD (3A00h): Interface Pixel Format

3A00H		COLMOD (Interface Pixel Format)																																																																													
Inst/Para	R/W	Address		D15-8	D7	D6	D5	D4	D3	D2	D1	D0	HEX																																																																		
		MIPI	Other																																																																												
COLMOD	W	3Ah	3A00h	x	SPI_IFPF_SEL	VIPF[2]	VIPF[1]	VIPF[0]	0	IFPF[2]	IFPF[1]	IFPF[0]	77																																																																		
Description	<p>This command sets the pixel format for the RGB image data used by the interface. If SPI_IFPF_SEL(3Ah-B7) = 1: The VIPF[2:0] pixel format used by the SPI interface If SPI_IFPF_SEL(3Ah-B7) = 0: The IFPF[2:0] pixel format used by the SPI / MCU interface</p> <p>If not used DPI interface, then the corresponding bits in the parameter are ignored.</p> <table border="1"> <thead> <tr> <th>Control Interface Color Format</th> <th>IFPF[2]</th> <th>IFPF[1]</th> <th>IFPF[0]</th> </tr> </thead> <tbody> <tr> <td>SPI 8 bit/pixel (256 colors); SPI 256 Gray (Support IF: SPI3/SPI4)</td> <td>0</td> <td>0</td> <td>1</td> </tr> <tr> <td>SPI 8 bit/pixel (256 colors); SPI 3-3-2 (Support IF: SPI3/SPI4)</td> <td>0</td> <td>1</td> <td>0</td> </tr> <tr> <td>SPI 3 bit/pixel (8 colors); SPI 1-1-1 (Support IF: SPI3/SPI4)</td> <td>0</td> <td>1</td> <td>1</td> </tr> <tr> <td>16bit/pixel (65,536 colors)</td> <td>1</td> <td>0</td> <td>1</td> </tr> <tr> <td>18bit/pixel (262,144 colors)</td> <td>1</td> <td>1</td> <td>0</td> </tr> <tr> <td>24bit/pixel (16.7M colors)</td> <td>1</td> <td>1</td> <td>1</td> </tr> </tbody> </table>													Control Interface Color Format	IFPF[2]	IFPF[1]	IFPF[0]	SPI 8 bit/pixel (256 colors); SPI 256 Gray (Support IF: SPI3/SPI4)	0	0	1	SPI 8 bit/pixel (256 colors); SPI 3-3-2 (Support IF: SPI3/SPI4)	0	1	0	SPI 3 bit/pixel (8 colors); SPI 1-1-1 (Support IF: SPI3/SPI4)	0	1	1	16bit/pixel (65,536 colors)	1	0	1	18bit/pixel (262,144 colors)	1	1	0	24bit/pixel (16.7M colors)	1	1	1																																						
	Control Interface Color Format	IFPF[2]	IFPF[1]	IFPF[0]																																																																											
	SPI 8 bit/pixel (256 colors); SPI 256 Gray (Support IF: SPI3/SPI4)	0	0	1																																																																											
	SPI 8 bit/pixel (256 colors); SPI 3-3-2 (Support IF: SPI3/SPI4)	0	1	0																																																																											
	SPI 3 bit/pixel (8 colors); SPI 1-1-1 (Support IF: SPI3/SPI4)	0	1	1																																																																											
	16bit/pixel (65,536 colors)	1	0	1																																																																											
	18bit/pixel (262,144 colors)	1	1	0																																																																											
	24bit/pixel (16.7M colors)	1	1	1																																																																											
	<p>SPI 1-1-1</p> <table border="1"> <thead> <tr> <th>RGB 1-1-1 Bit</th> <th>DCX</th> <th>D[7]</th> <th>D[6]</th> <th>D[5]</th> <th>D[4]</th> <th>D[3]</th> <th>D[2]</th> <th>D[1]</th> <th>D[0]</th> <th>Note</th> </tr> </thead> <tbody> <tr> <td>CMDWR</td> <td>0</td> <td>0</td> <td>0</td> <td>0</td> <td>0</td> <td>0</td> <td>0</td> <td>0</td> <td>0</td> <td>0x2C for GRAM Write</td> </tr> <tr> <td>1st RAM Data Write</td> <td>1</td> <td>X</td> <td>X</td> <td>R1[0]</td> <td>G1[0]</td> <td>B1[0]</td> <td>R2[0]</td> <td>G2[0]</td> <td>B2[0]</td> <td>1,2 pixel Data Write</td> </tr> <tr> <td>2nd RAM Data Write</td> <td>1</td> <td>X</td> <td>X</td> <td>R3[0]</td> <td>G3[0]</td> <td>B3[0]</td> <td>R4[0]</td> <td>G4[0]</td> <td>B4[0]</td> <td>3,4 pixel Data Write</td> </tr> <tr> <td>3rd RAM Data Write</td> <td>1</td> <td>X</td> <td>X</td> <td>R5[0]</td> <td>G5[0]</td> <td>B5[0]</td> <td>R6[0]</td> <td>G6[0]</td> <td>B6[0]</td> <td>5,6 pixel Data Write</td> </tr> <tr> <td>So on...</td> <td></td> <td></td> <td></td> <td></td> <td></td> <td></td> <td></td> <td></td> <td></td> <td></td> </tr> </tbody> </table>													RGB 1-1-1 Bit	DCX	D[7]	D[6]	D[5]	D[4]	D[3]	D[2]	D[1]	D[0]	Note	CMDWR	0	0	0	0	0	0	0	0	0	0x2C for GRAM Write	1st RAM Data Write	1	X	X	R1[0]	G1[0]	B1[0]	R2[0]	G2[0]	B2[0]	1,2 pixel Data Write	2nd RAM Data Write	1	X	X	R3[0]	G3[0]	B3[0]	R4[0]	G4[0]	B4[0]	3,4 pixel Data Write	3rd RAM Data Write	1	X	X	R5[0]	G5[0]	B5[0]	R6[0]	G6[0]	B6[0]	5,6 pixel Data Write	So on...										
	RGB 1-1-1 Bit	DCX	D[7]	D[6]	D[5]	D[4]	D[3]	D[2]	D[1]	D[0]	Note																																																																				
CMDWR	0	0	0	0	0	0	0	0	0	0x2C for GRAM Write																																																																					
1st RAM Data Write	1	X	X	R1[0]	G1[0]	B1[0]	R2[0]	G2[0]	B2[0]	1,2 pixel Data Write																																																																					
2nd RAM Data Write	1	X	X	R3[0]	G3[0]	B3[0]	R4[0]	G4[0]	B4[0]	3,4 pixel Data Write																																																																					
3rd RAM Data Write	1	X	X	R5[0]	G5[0]	B5[0]	R6[0]	G6[0]	B6[0]	5,6 pixel Data Write																																																																					
So on...																																																																															
<p>SPI 3-3-2</p> <table border="1"> <thead> <tr> <th>RGB 3-3-2 Bit</th> <th>DCX</th> <th>D[7]</th> <th>D[6]</th> <th>D[5]</th> <th>D[4]</th> <th>D[3]</th> <th>D[2]</th> <th>D[1]</th> <th>D[0]</th> <th>Note</th> </tr> </thead> <tbody> <tr> <td>CMDWR</td> <td>0</td> <td>0</td> <td>0</td> <td>0</td> <td>0</td> <td>0</td> <td>0</td> <td>0</td> <td>0</td> <td>0x2C for GRAM Write</td> </tr> <tr> <td>1st RAM Data Write</td> <td>1</td> <td>R1[2]</td> <td>R1[1]</td> <td>R1[0]</td> <td>G1[2]</td> <td>G1[1]</td> <td>G1[0]</td> <td>B1[1]</td> <td>B1[0]</td> <td>1st pixel Data Write</td> </tr> <tr> <td>2nd RAM Data Write</td> <td>1</td> <td>R2[2]</td> <td>R2[1]</td> <td>R2[0]</td> <td>G2[2]</td> <td>G2[1]</td> <td>G2[0]</td> <td>B2[1]</td> <td>B2[0]</td> <td>2nd pixel Data Write</td> </tr> <tr> <td>3rd RAM Data Write</td> <td>1</td> <td>R3[2]</td> <td>R3[1]</td> <td>R3[0]</td> <td>G3[2]</td> <td>G3[1]</td> <td>G3[0]</td> <td>B3[1]</td> <td>B3[0]</td> <td>3rd pixel Data Write</td> </tr> <tr> <td>So on...</td> <td></td> <td></td> <td></td> <td></td> <td></td> <td></td> <td></td> <td></td> <td></td> <td></td> </tr> </tbody> </table>													RGB 3-3-2 Bit	DCX	D[7]	D[6]	D[5]	D[4]	D[3]	D[2]	D[1]	D[0]	Note	CMDWR	0	0	0	0	0	0	0	0	0	0x2C for GRAM Write	1st RAM Data Write	1	R1[2]	R1[1]	R1[0]	G1[2]	G1[1]	G1[0]	B1[1]	B1[0]	1st pixel Data Write	2nd RAM Data Write	1	R2[2]	R2[1]	R2[0]	G2[2]	G2[1]	G2[0]	B2[1]	B2[0]	2nd pixel Data Write	3rd RAM Data Write	1	R3[2]	R3[1]	R3[0]	G3[2]	G3[1]	G3[0]	B3[1]	B3[0]	3rd pixel Data Write	So on...											
RGB 3-3-2 Bit	DCX	D[7]	D[6]	D[5]	D[4]	D[3]	D[2]	D[1]	D[0]	Note																																																																					
CMDWR	0	0	0	0	0	0	0	0	0	0x2C for GRAM Write																																																																					
1st RAM Data Write	1	R1[2]	R1[1]	R1[0]	G1[2]	G1[1]	G1[0]	B1[1]	B1[0]	1st pixel Data Write																																																																					
2nd RAM Data Write	1	R2[2]	R2[1]	R2[0]	G2[2]	G2[1]	G2[0]	B2[1]	B2[0]	2nd pixel Data Write																																																																					
3rd RAM Data Write	1	R3[2]	R3[1]	R3[0]	G3[2]	G3[1]	G3[0]	B3[1]	B3[0]	3rd pixel Data Write																																																																					
So on...																																																																															
<p>SPI 256 Gray</p> <table border="1"> <thead> <tr> <th>RGB 256 Gray</th> <th>DCX</th> <th>D[7]</th> <th>D[6]</th> <th>D[5]</th> <th>D[4]</th> <th>D[3]</th> <th>D[2]</th> <th>D[1]</th> <th>D[0]</th> <th>Note</th> </tr> </thead> <tbody> <tr> <td>CMDWR</td> <td>0</td> <td>0</td> <td>0</td> <td>0</td> <td>0</td> <td>0</td> <td>0</td> <td>0</td> <td>0</td> <td>0x2C for GRAM Write</td> </tr> <tr> <td>1st RAM Data Write</td> <td>1</td> <td>P1[7]</td> <td>P1[6]</td> <td>P1[5]</td> <td>P1[4]</td> <td>P1[3]</td> <td>P1[2]</td> <td>P1[1]</td> <td>P1[0]</td> <td>1st pixel Data Write</td> </tr> <tr> <td>2nd RAM Data Write</td> <td>1</td> <td>P2[7]</td> <td>P2[6]</td> <td>P2[5]</td> <td>P2[4]</td> <td>P2[3]</td> <td>P2[2]</td> <td>P2[1]</td> <td>P2[0]</td> <td>2nd pixel Data Write</td> </tr> <tr> <td>3rd RAM Data Write</td> <td>1</td> <td>P3[7]</td> <td>P3[6]</td> <td>P3[5]</td> <td>P3[4]</td> <td>P3[3]</td> <td>P3[2]</td> <td>P3[1]</td> <td>P3[0]</td> <td>3rd pixel Data Write</td> </tr> <tr> <td>So on...</td> <td></td> <td></td> <td></td> <td></td> <td></td> <td></td> <td></td> <td></td> <td></td> <td></td> </tr> </tbody> </table>													RGB 256 Gray	DCX	D[7]	D[6]	D[5]	D[4]	D[3]	D[2]	D[1]	D[0]	Note	CMDWR	0	0	0	0	0	0	0	0	0	0x2C for GRAM Write	1st RAM Data Write	1	P1[7]	P1[6]	P1[5]	P1[4]	P1[3]	P1[2]	P1[1]	P1[0]	1st pixel Data Write	2nd RAM Data Write	1	P2[7]	P2[6]	P2[5]	P2[4]	P2[3]	P2[2]	P2[1]	P2[0]	2nd pixel Data Write	3rd RAM Data Write	1	P3[7]	P3[6]	P3[5]	P3[4]	P3[3]	P3[2]	P3[1]	P3[0]	3rd pixel Data Write	So on...											
RGB 256 Gray	DCX	D[7]	D[6]	D[5]	D[4]	D[3]	D[2]	D[1]	D[0]	Note																																																																					
CMDWR	0	0	0	0	0	0	0	0	0	0x2C for GRAM Write																																																																					
1st RAM Data Write	1	P1[7]	P1[6]	P1[5]	P1[4]	P1[3]	P1[2]	P1[1]	P1[0]	1st pixel Data Write																																																																					
2nd RAM Data Write	1	P2[7]	P2[6]	P2[5]	P2[4]	P2[3]	P2[2]	P2[1]	P2[0]	2nd pixel Data Write																																																																					
3rd RAM Data Write	1	P3[7]	P3[6]	P3[5]	P3[4]	P3[3]	P3[2]	P3[1]	P3[0]	3rd pixel Data Write																																																																					
So on...																																																																															

Restriction													
Register Availability	<table border="1"> <thead> <tr> <th>Status</th> <th>Availability</th> </tr> </thead> <tbody> <tr> <td>Normal Mode On, Idle Mode Off, Sleep Out</td> <td>Yes</td> </tr> <tr> <td>Normal Mode On, Idle Mode On, Sleep Out</td> <td>Yes</td> </tr> <tr> <td>Partial Mode On, Idle Mode Off, Sleep Out</td> <td>Yes</td> </tr> <tr> <td>Partial Mode On, Idle Mode On, Sleep Out</td> <td>Yes</td> </tr> <tr> <td>Sleep In</td> <td>Yes</td> </tr> </tbody> </table>	Status	Availability	Normal Mode On, Idle Mode Off, Sleep Out	Yes	Normal Mode On, Idle Mode On, Sleep Out	Yes	Partial Mode On, Idle Mode Off, Sleep Out	Yes	Partial Mode On, Idle Mode On, Sleep Out	Yes	Sleep In	Yes
Status	Availability												
Normal Mode On, Idle Mode Off, Sleep Out	Yes												
Normal Mode On, Idle Mode On, Sleep Out	Yes												
Partial Mode On, Idle Mode Off, Sleep Out	Yes												
Partial Mode On, Idle Mode On, Sleep Out	Yes												
Sleep In	Yes												
Default	<table border="1"> <thead> <tr> <th>Status</th> <th>Default Value</th> </tr> </thead> <tbody> <tr> <td>Power On Sequence</td> <td>77h</td> </tr> <tr> <td>SW Reset</td> <td>77h</td> </tr> <tr> <td>HW Reset</td> <td>77h</td> </tr> </tbody> </table>	Status	Default Value	Power On Sequence	77h	SW Reset	77h	HW Reset	77h				
Status	Default Value												
Power On Sequence	77h												
SW Reset	77h												
HW Reset	77h												
Flow chart	<p>Example :</p> <pre> graph TD A([16-bits/Pixel Mode]) --> B[COLMOD (3Ah)] B --> C[/1st Parameter (06h)/] C --> D([18-bits/Pixel Mode]) </pre> <p>Legend</p> <ul style="list-style-type: none"> Command Parameter Display Action Mode Sequential transfer 												

RAMWRC (3C00h): Memory Continuous Write

3C00H		RAMWRC																						
Inst/Para	R/W	Address		D15-8	D7	D6	D5	D4	D3	D2	D1	D0	HEX											
		MIPI	Other																					
RAMWR	W	3Ch	3C00h	X	0	0	1	1	1	1	0	0	3C											
			1 st Pixel	X	D ₁₇	D ₁₆	D ₁₅	D ₁₄	D ₁₃	D ₁₂	D ₁₁	D ₁₀												
			:	X	:	:	:	:	:	:	:	:	:											
			N th Pixel	X	D _{N7}	D _{N6}	D _{N5}	D _{N4}	D _{N3}	D _{N2}	D _{N1}	D _{N0}												
Description	This command transfers image data from the host processor to the display module's frame memory continuing from the pixel location following the previous write_memory_continue or write_memory_start command.																							
Restriction	A Memory Write should follow a CASET(2Ah), RASET(2Bh) or MADCTR(36h) to define the write location. Otherwise, data written with RAMWR(2Ch) and any following RAMWRC(3Ch) commands is written to undefined locations.																							
Register Availability	<table border="1"> <thead> <tr> <th>Status</th> <th>Availability</th> </tr> </thead> <tbody> <tr> <td>Normal Mode On, Idle Mode Off, Sleep Out</td> <td>Yes</td> </tr> <tr> <td>Normal Mode On, Idle Mode On, Sleep Out</td> <td>Yes</td> </tr> <tr> <td>Partial Mode On, Idle Mode Off, Sleep Out</td> <td>Yes</td> </tr> <tr> <td>Partial Mode On, Idle Mode On, Sleep Out</td> <td>Yes</td> </tr> <tr> <td>Sleep In</td> <td>Yes</td> </tr> </tbody> </table>												Status	Availability	Normal Mode On, Idle Mode Off, Sleep Out	Yes	Normal Mode On, Idle Mode On, Sleep Out	Yes	Partial Mode On, Idle Mode Off, Sleep Out	Yes	Partial Mode On, Idle Mode On, Sleep Out	Yes	Sleep In	Yes
Status	Availability																							
Normal Mode On, Idle Mode Off, Sleep Out	Yes																							
Normal Mode On, Idle Mode On, Sleep Out	Yes																							
Partial Mode On, Idle Mode Off, Sleep Out	Yes																							
Partial Mode On, Idle Mode On, Sleep Out	Yes																							
Sleep In	Yes																							
Default	<table border="1"> <thead> <tr> <th>Status</th> <th>Default Value</th> </tr> </thead> <tbody> <tr> <td>Power On Sequence</td> <td>Contents of memory is set randomly</td> </tr> <tr> <td>SW Reset</td> <td>Contents of memory is not cleared</td> </tr> <tr> <td>HW Reset</td> <td>Contents of memory is not cleared</td> </tr> </tbody> </table>												Status	Default Value	Power On Sequence	Contents of memory is set randomly	SW Reset	Contents of memory is not cleared	HW Reset	Contents of memory is not cleared				
Status	Default Value																							
Power On Sequence	Contents of memory is set randomly																							
SW Reset	Contents of memory is not cleared																							
HW Reset	Contents of memory is not cleared																							

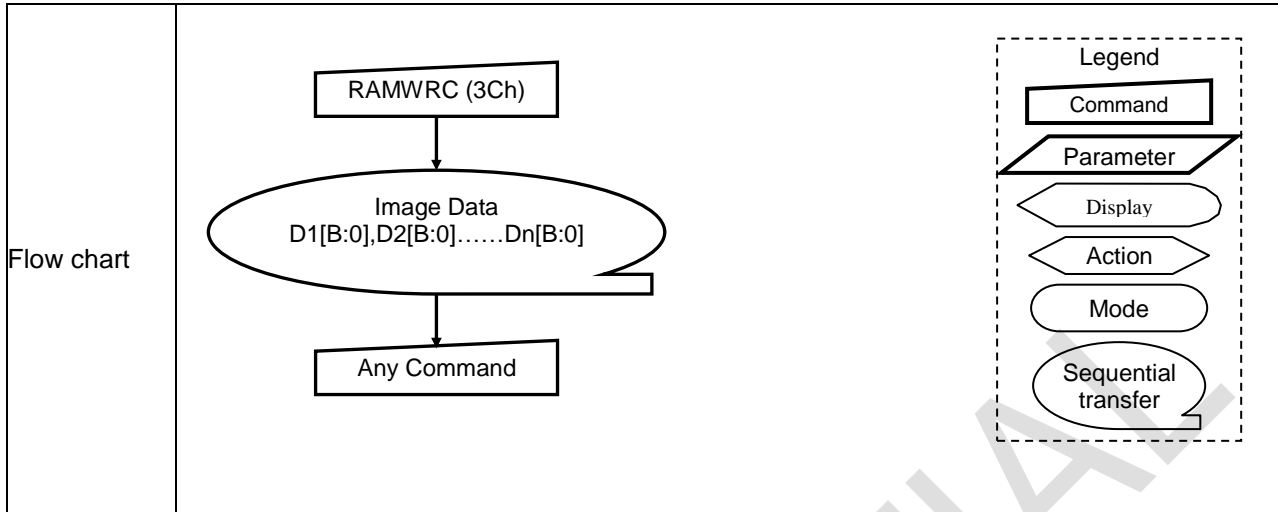

CONFIDENTIAL

STESL(4400h) : Set_Tear_Scanline

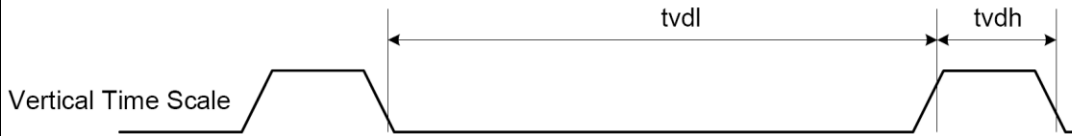
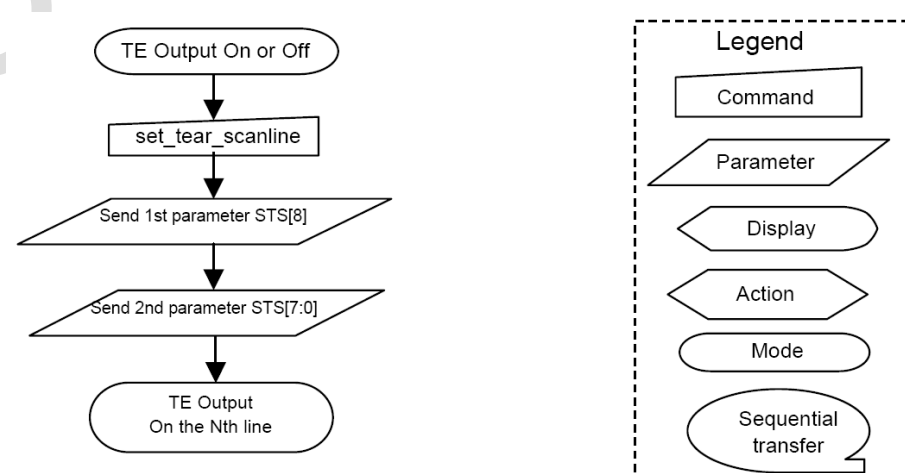
4400H		STESL(Set_Tear_Scanline)																							
Inst/Para	R/W	Address		D15-8	D7	D6	D5	D4	D3	D2	D1	D0	HEX												
		MIPI	Other																						
STESL	W	44h	4400h	x	STS[15]	STS[14]	STS[13]	STS[12]	STS[11]	STS[10]	STS[9]	STS[8]	00												
			4401h	x	STS[7]	STS[6]	STS[5]	STS[4]	STS[3]	STS[2]	STS[1]	STS[0]	00												
Description	<p>This command turns on the display Tearing Effect output signal on the TE signal line when the display reaches line N. The TE signal is not affected by changing set_address_mode bit B4. The Tearing Effect Line On has one parameter that describes the Tearing Effect Output Line mode.</p>  <p>The Tearing Effect Output line shall be active low when the display module is in Sleep mode.</p>																								
Restriction																									
Register Availability	<table border="1"> <thead> <tr> <th>Status</th> <th>Availability</th> </tr> </thead> <tbody> <tr> <td>Normal Mode On, Idle Mode Off, Sleep Out</td> <td>Yes</td> </tr> <tr> <td>Normal Mode On, Idle Mode On, Sleep Out</td> <td>Yes</td> </tr> <tr> <td>Partial Mode On, Idle Mode Off, Sleep Out</td> <td>Yes</td> </tr> <tr> <td>Partial Mode On, Idle Mode On, Sleep Out</td> <td>Yes</td> </tr> <tr> <td>Sleep In</td> <td>Yes</td> </tr> </tbody> </table>													Status	Availability	Normal Mode On, Idle Mode Off, Sleep Out	Yes	Normal Mode On, Idle Mode On, Sleep Out	Yes	Partial Mode On, Idle Mode Off, Sleep Out	Yes	Partial Mode On, Idle Mode On, Sleep Out	Yes	Sleep In	Yes
Status	Availability																								
Normal Mode On, Idle Mode Off, Sleep Out	Yes																								
Normal Mode On, Idle Mode On, Sleep Out	Yes																								
Partial Mode On, Idle Mode Off, Sleep Out	Yes																								
Partial Mode On, Idle Mode On, Sleep Out	Yes																								
Sleep In	Yes																								
Default	<table border="1"> <thead> <tr> <th>Status</th> <th>Default Value</th> </tr> </thead> <tbody> <tr> <td>Power On Sequence</td> <td>STS[15:0]=16'h0000</td> </tr> <tr> <td>SW Reset</td> <td>STS[15:0]=16'h0000</td> </tr> <tr> <td>HW Reset</td> <td>STS[15:0]=16'h0000</td> </tr> </tbody> </table>													Status	Default Value	Power On Sequence	STS[15:0]=16'h0000	SW Reset	STS[15:0]=16'h0000	HW Reset	STS[15:0]=16'h0000				
Status	Default Value																								
Power On Sequence	STS[15:0]=16'h0000																								
SW Reset	STS[15:0]=16'h0000																								
HW Reset	STS[15:0]=16'h0000																								
Flow Chart																									

GSL (4500h) : Get_Scanline

4500H		GSL(Get_Scanline)																							
Inst/Para	R/W	Address		D15-8	D7	D6	D5	D4	D3	D2	D1	D0	HEX												
		MIPI	Other																						
GSL	R	45h	4500h	x	GTS[15]	GTS[14]	GTS[13]	GTS[12]	GTS[11]	GTS[10]	GTS[9]	GTS[8]	0x												
			4501h	x	GTS[7]	GTS[6]	GTS[5]	GTS[4]	GTS[3]	GTS[2]	GTS[1]	GTS[0]	xx												
Description	<p>The display returns the current scan line, N, used to update the display device. The total number of scan lines on a display device is defined as VSYNC + VBP + VACT + VFP. The first scan line is defined as the first line of V-Sync and is denoted as Line 0. When in Sleep Mode, the value returned by get scanline is undefined.</p>																								
Restriction	-																								
Register Availability	<table border="1"> <thead> <tr> <th>Status</th> <th>Availability</th> </tr> </thead> <tbody> <tr> <td>Normal Mode On, Idle Mode Off, Sleep Out</td> <td>Yes</td> </tr> <tr> <td>Normal Mode On, Idle Mode On, Sleep Out</td> <td>Yes</td> </tr> <tr> <td>Partial Mode On, Idle Mode Off, Sleep Out</td> <td>Yes</td> </tr> <tr> <td>Partial Mode On, Idle Mode On, Sleep Out</td> <td>Yes</td> </tr> <tr> <td>Sleep In</td> <td>Yes</td> </tr> </tbody> </table>													Status	Availability	Normal Mode On, Idle Mode Off, Sleep Out	Yes	Normal Mode On, Idle Mode On, Sleep Out	Yes	Partial Mode On, Idle Mode Off, Sleep Out	Yes	Partial Mode On, Idle Mode On, Sleep Out	Yes	Sleep In	Yes
Status	Availability																								
Normal Mode On, Idle Mode Off, Sleep Out	Yes																								
Normal Mode On, Idle Mode On, Sleep Out	Yes																								
Partial Mode On, Idle Mode Off, Sleep Out	Yes																								
Partial Mode On, Idle Mode On, Sleep Out	Yes																								
Sleep In	Yes																								
Flow Chart	<pre> graph TD A[get_scanline] --> B[Wait 3us] B --> C[/Dummy Read/] C --> D[Send 1st parameter GTS[9:8]] D --> E[/Send 2nd parameter GTS[7:0]/] </pre>																								

DSTBON (4F00h): Deep Standby Mode On

4F00H		DSTBON(Deep Standby Mode On)																							
Inst/Para	R/W	Address		D15-8	D7	D6	D5	D4	D3	D2	D1	D0	HEX												
		MIPI	Other																						
DSTBON	W	4Fh	4F00h	x	0	0	0	0	0	0	0	DSTB	00												
Description	<p>This command is used to enter deep standby mode. DSTB="1", enter deep standby mode.</p> <p>Notes:</p> <ol style="list-style-type: none"> To exit Deep Standby Mode, input low pulse more than 3 msec to pin RESX. For MIPI IF, if deep standby mode is used, please pull HSSI_CLK_P/N & HSSI_D0~D1_P/N to GND after executing deep standby command. 																								
Restriction	-																								
Register Availability	<table border="1"> <thead> <tr> <th>Status</th> <th>Availability</th> </tr> </thead> <tbody> <tr> <td>Normal Mode On, Idle Mode Off, Sleep Out</td> <td>Yes</td> </tr> <tr> <td>Normal Mode On, Idle Mode On, Sleep Out</td> <td>Yes</td> </tr> <tr> <td>Partial Mode On, Idle Mode Off, Sleep Out</td> <td>Yes</td> </tr> <tr> <td>Partial Mode On, Idle Mode On, Sleep Out</td> <td>Yes</td> </tr> <tr> <td>Sleep In</td> <td>Yes</td> </tr> </tbody> </table>													Status	Availability	Normal Mode On, Idle Mode Off, Sleep Out	Yes	Normal Mode On, Idle Mode On, Sleep Out	Yes	Partial Mode On, Idle Mode Off, Sleep Out	Yes	Partial Mode On, Idle Mode On, Sleep Out	Yes	Sleep In	Yes
Status	Availability																								
Normal Mode On, Idle Mode Off, Sleep Out	Yes																								
Normal Mode On, Idle Mode On, Sleep Out	Yes																								
Partial Mode On, Idle Mode Off, Sleep Out	Yes																								
Partial Mode On, Idle Mode On, Sleep Out	Yes																								
Sleep In	Yes																								
Default	<table border="1"> <thead> <tr> <th>Status</th> <th>Default Value</th> </tr> </thead> <tbody> <tr> <td>Power On Sequence</td> <td>00h</td> </tr> <tr> <td>SW Reset</td> <td>00h</td> </tr> <tr> <td>HW Reset</td> <td>00h</td> </tr> </tbody> </table>													Status	Default Value	Power On Sequence	00h	SW Reset	00h	HW Reset	00h				
Status	Default Value																								
Power On Sequence	00h																								
SW Reset	00h																								
HW Reset	00h																								
Flow chart	<pre> graph TD A[DSTBON (4Fh)] --> B[/Parameter DSTB=1/] B --> C([Deep Standby Mode]) </pre> <p>Legend</p> <ul style="list-style-type: none"> Command: Rectangle Parameter: Parallelogram Display: Oval Action: Arrow Mode: Rounded rectangle Sequential transfer: Oval with tail 																								

WRDISBV (5100h): Write Display Brightness

5100H		WRDISBV																							
Inst/Para	R/W	Address		D15-8	D7	D6	D5	D4	D3	D2	D1	D0	HEX												
		MIPI	Other																						
WRDISBV	W	51h	5100h	x	DBV7	DBV6	DBV5	DBV4	DBV3	DBV2	DBV1	DBV0	00												
Description	<p>This command is used to adjust brightness value. In principle relationship is that 00h value means the lowest brightness and FFh value means the highest brightness.</p>																								
Restriction	The display supplier cannot use this command for tuning																								
Register Availability	<table border="1"> <thead> <tr> <th>Status</th> <th>Availability</th> </tr> </thead> <tbody> <tr> <td>Normal Mode On, Idle Mode Off, Sleep Out</td> <td>Yes</td> </tr> <tr> <td>Normal Mode On, Idle Mode On, Sleep Out</td> <td>Yes</td> </tr> <tr> <td>Partial Mode On, Idle Mode Off, Sleep Out</td> <td>Yes</td> </tr> <tr> <td>Partial Mode On, Idle Mode On, Sleep Out</td> <td>Yes</td> </tr> <tr> <td>Sleep In</td> <td>Yes</td> </tr> </tbody> </table>													Status	Availability	Normal Mode On, Idle Mode Off, Sleep Out	Yes	Normal Mode On, Idle Mode On, Sleep Out	Yes	Partial Mode On, Idle Mode Off, Sleep Out	Yes	Partial Mode On, Idle Mode On, Sleep Out	Yes	Sleep In	Yes
Status	Availability																								
Normal Mode On, Idle Mode Off, Sleep Out	Yes																								
Normal Mode On, Idle Mode On, Sleep Out	Yes																								
Partial Mode On, Idle Mode Off, Sleep Out	Yes																								
Partial Mode On, Idle Mode On, Sleep Out	Yes																								
Sleep In	Yes																								
Default	<table border="1"> <thead> <tr> <th>Status</th> <th>Default Value</th> </tr> </thead> <tbody> <tr> <td>Power On Sequence</td> <td>00h</td> </tr> <tr> <td>SW Reset</td> <td>00h</td> </tr> <tr> <td>HW Reset</td> <td>00h</td> </tr> </tbody> </table>													Status	Default Value	Power On Sequence	00h	SW Reset	00h	HW Reset	00h				
Status	Default Value																								
Power On Sequence	00h																								
SW Reset	00h																								
HW Reset	00h																								
Flow chart	<pre> graph TD A[WRDISBV (51h)] --> B[/Parameter DBV[7:0]/] B --> C([New Brightness Loaded]) </pre> <p>Legend</p> <ul style="list-style-type: none"> Command: Rectangle Parameter: Parallelogram Display: Oval Action: Arrow Mode: Rounded Rectangle Sequential transfer: Speech bubble 																								

RDDISBV (5200h): Read Display Brightness

5200H	RDDISBV																								
Inst/Para	R/W	Address		D15-8	D7	D6	D5	D4	D3	D2	D1	D0	HEX												
		MIPI	Other																						
RDDISBV	R	52h	5200h	x	DBV7	DBV6	DBV5	DBV4	DBV3	DBV2	DBV1	DBV0	00												
Description	This command returns brightness value. In principle relationship is that 00h value means the lowest brightness and FFh value means the highest brightness.																								
Restriction																									
Register Availability	<table border="1"> <thead> <tr> <th>Status</th> <th>Availability</th> </tr> </thead> <tbody> <tr> <td>Normal Mode On, Idle Mode Off, Sleep Out</td> <td>Yes</td> </tr> <tr> <td>Normal Mode On, Idle Mode On, Sleep Out</td> <td>Yes</td> </tr> <tr> <td>Partial Mode On, Idle Mode Off, Sleep Out</td> <td>Yes</td> </tr> <tr> <td>Partial Mode On, Idle Mode On, Sleep Out</td> <td>Yes</td> </tr> <tr> <td>Sleep In</td> <td>Yes</td> </tr> </tbody> </table>													Status	Availability	Normal Mode On, Idle Mode Off, Sleep Out	Yes	Normal Mode On, Idle Mode On, Sleep Out	Yes	Partial Mode On, Idle Mode Off, Sleep Out	Yes	Partial Mode On, Idle Mode On, Sleep Out	Yes	Sleep In	Yes
Status	Availability																								
Normal Mode On, Idle Mode Off, Sleep Out	Yes																								
Normal Mode On, Idle Mode On, Sleep Out	Yes																								
Partial Mode On, Idle Mode Off, Sleep Out	Yes																								
Partial Mode On, Idle Mode On, Sleep Out	Yes																								
Sleep In	Yes																								
Default	<table border="1"> <thead> <tr> <th>Status</th> <th>Default Value</th> </tr> </thead> <tbody> <tr> <td>Power On Sequence</td> <td>00h</td> </tr> <tr> <td>SW Reset</td> <td>00h</td> </tr> <tr> <td>HW Reset</td> <td>00h</td> </tr> </tbody> </table>													Status	Default Value	Power On Sequence	00h	SW Reset	00h	HW Reset	00h				
Status	Default Value																								
Power On Sequence	00h																								
SW Reset	00h																								
HW Reset	00h																								
Flow Chart	<p>The flow chart shows a Host Driver sending a command (rectangle) to a display (parallelogram) labeled "Send parameter DBV[7:0]". A legend defines symbols: Command (rectangle), Parameter (parallelogram), Display (trapezoid), Action (arrow), Mode (oval), and Sequential transfer (oval with tail).</p>																								

WRCTRLD (5300h): Write Display Control

5300H		WRDISBV																									
Inst/Para	R/W	Address		D15-8	D7	D6	D5	D4	D3	D2	D1	D0	HEX														
		MIPI	Other																								
WRCTRLD	W	53h	5300h	x	0	0	BCTRL	0	DD	0	0	0	28														
Description	BCTRL: Brightness control ,1=enable DD: Display dimming control ,1=enable																										
Restriction	The display supplier cannot use this command for tuning																										
Register Availability	<table border="1"> <thead> <tr> <th>Status</th> <th>Availability</th> </tr> </thead> <tbody> <tr> <td>Normal Mode On, Idle Mode Off, Sleep Out</td> <td>Yes</td> </tr> <tr> <td>Normal Mode On, Idle Mode On, Sleep Out</td> <td>Yes</td> </tr> <tr> <td>Partial Mode On, Idle Mode Off, Sleep Out</td> <td>Yes</td> </tr> <tr> <td>Partial Mode On, Idle Mode On, Sleep Out</td> <td>Yes</td> </tr> <tr> <td>Sleep In</td> <td>Yes</td> </tr> </tbody> </table>													Status	Availability	Normal Mode On, Idle Mode Off, Sleep Out	Yes	Normal Mode On, Idle Mode On, Sleep Out	Yes	Partial Mode On, Idle Mode Off, Sleep Out	Yes	Partial Mode On, Idle Mode On, Sleep Out	Yes	Sleep In	Yes		
Status	Availability																										
Normal Mode On, Idle Mode Off, Sleep Out	Yes																										
Normal Mode On, Idle Mode On, Sleep Out	Yes																										
Partial Mode On, Idle Mode Off, Sleep Out	Yes																										
Partial Mode On, Idle Mode On, Sleep Out	Yes																										
Sleep In	Yes																										
Default	<table border="1"> <thead> <tr> <th>Status</th> <th>Default Value</th> </tr> </thead> <tbody> <tr> <td>Power On Sequence</td> <td>28h</td> </tr> <tr> <td>SW Reset</td> <td>28h</td> </tr> <tr> <td>HW Reset</td> <td>28h</td> </tr> </tbody> </table>													Status	Default Value	Power On Sequence	28h	SW Reset	28h	HW Reset	28h						
Status	Default Value																										
Power On Sequence	28h																										
SW Reset	28h																										
HW Reset	28h																										
Flow chart	<div style="display: flex; align-items: center;"> <div style="margin-right: 20px;"> <pre> graph TD A[WRCTRLD (53h)] --> B[/Parameter BCTRL/] </pre> </div> <div> <table border="1" style="border-style: dashed;"> <thead> <tr> <th colspan="2">Legend</th> </tr> </thead> <tbody> <tr> <td></td> <td>Command</td> </tr> <tr> <td></td> <td>Parameter</td> </tr> <tr> <td></td> <td>Display</td> </tr> <tr> <td></td> <td>Action</td> </tr> <tr> <td></td> <td>Mode</td> </tr> <tr> <td></td> <td>Sequential transfer</td> </tr> </tbody> </table> </div> </div>													Legend			Command		Parameter		Display		Action		Mode		Sequential transfer
Legend																											
	Command																										
	Parameter																										
	Display																										
	Action																										
	Mode																										
	Sequential transfer																										

RDCTRLD (5400h): Read Display Control

5400H	RDISBV																								
Inst/Para	R/W	Address		D15-8	D7	D6	D5	D4	D3	D2	D1	D0	HEX												
		MIPI	Other																						
RDCTRLD	R	54h	5400h	x	0	0	BCTRL	0	DD	0	0	0	28												
Description	BCTRL: Brightness control ,1=enable DD: Display dimming control ,1=enable																								
Restriction	-																								
Register Availability	<table border="1"> <thead> <tr> <th>Status</th> <th>Availability</th> </tr> </thead> <tbody> <tr> <td>Normal Mode On, Idle Mode Off, Sleep Out</td> <td>Yes</td> </tr> <tr> <td>Normal Mode On, Idle Mode On, Sleep Out</td> <td>Yes</td> </tr> <tr> <td>Partial Mode On, Idle Mode Off, Sleep Out</td> <td>Yes</td> </tr> <tr> <td>Partial Mode On, Idle Mode On, Sleep Out</td> <td>Yes</td> </tr> <tr> <td>Sleep In</td> <td>Yes</td> </tr> </tbody> </table>													Status	Availability	Normal Mode On, Idle Mode Off, Sleep Out	Yes	Normal Mode On, Idle Mode On, Sleep Out	Yes	Partial Mode On, Idle Mode Off, Sleep Out	Yes	Partial Mode On, Idle Mode On, Sleep Out	Yes	Sleep In	Yes
Status	Availability																								
Normal Mode On, Idle Mode Off, Sleep Out	Yes																								
Normal Mode On, Idle Mode On, Sleep Out	Yes																								
Partial Mode On, Idle Mode Off, Sleep Out	Yes																								
Partial Mode On, Idle Mode On, Sleep Out	Yes																								
Sleep In	Yes																								
Default	<table border="1"> <thead> <tr> <th>Status</th> <th>Default Value</th> </tr> </thead> <tbody> <tr> <td>Power On Sequence</td> <td>28h</td> </tr> <tr> <td>SW Reset</td> <td>28h</td> </tr> <tr> <td>HW Reset</td> <td>28h</td> </tr> </tbody> </table>													Status	Default Value	Power On Sequence	28h	SW Reset	28h	HW Reset	28h				
Status	Default Value																								
Power On Sequence	28h																								
SW Reset	28h																								
HW Reset	28h																								
Flow Chart	<p>The flow chart illustrates the Host sending the RDCTRLD (54hH) command to the Driver. The Driver then sends the parameter BCTRL. A legend defines the symbols used: a rectangle for Command, a trapezoid for Parameter, a pointed rectangle for Display, another pointed rectangle for Action, an oval for Mode, and an oval with a tail for Sequential transfer.</p>																								

WRRADACL (5500h): RAD_ACL Control

5500H	RDISBV																								
Inst/Para	R/W	Address		D15-8	D7	D6	D5	D4	D3	D2	D1	D0	HEX												
		MIPI	Other																						
WRRADACL	W	55h	5500h	x	0	0	0	0	0	0	RAD_ACL[1:0]		00												
Description	This command is used to control Raydium specific function for ACL (Auto Current Limit) RAD_ACL[1:0]=11, Enable Raydium ACL function. RAD_ACL[1:0]=00, Disable Raydium ACL function.																								
Restriction																									
Register Availability	<table border="1"> <thead> <tr> <th>Status</th> <th>Availability</th> </tr> </thead> <tbody> <tr> <td>Normal Mode On, Idle Mode Off, Sleep Out</td> <td>Yes</td> </tr> <tr> <td>Normal Mode On, Idle Mode On, Sleep Out</td> <td>Yes</td> </tr> <tr> <td>Partial Mode On, Idle Mode Off, Sleep Out</td> <td>Yes</td> </tr> <tr> <td>Partial Mode On, Idle Mode On, Sleep Out</td> <td>Yes</td> </tr> <tr> <td>Sleep In</td> <td>Yes</td> </tr> </tbody> </table>													Status	Availability	Normal Mode On, Idle Mode Off, Sleep Out	Yes	Normal Mode On, Idle Mode On, Sleep Out	Yes	Partial Mode On, Idle Mode Off, Sleep Out	Yes	Partial Mode On, Idle Mode On, Sleep Out	Yes	Sleep In	Yes
Status	Availability																								
Normal Mode On, Idle Mode Off, Sleep Out	Yes																								
Normal Mode On, Idle Mode On, Sleep Out	Yes																								
Partial Mode On, Idle Mode Off, Sleep Out	Yes																								
Partial Mode On, Idle Mode On, Sleep Out	Yes																								
Sleep In	Yes																								
Default	<table border="1"> <thead> <tr> <th>Status</th> <th>Default Value</th> </tr> </thead> <tbody> <tr> <td>Power On Sequence</td> <td>00h</td> </tr> <tr> <td>SW Reset</td> <td>00h</td> </tr> <tr> <td>HW Reset</td> <td>00h</td> </tr> </tbody> </table>													Status	Default Value	Power On Sequence	00h	SW Reset	00h	HW Reset	00h				
Status	Default Value																								
Power On Sequence	00h																								
SW Reset	00h																								
HW Reset	00h																								
Flow Chart	<p>The flow chart illustrates the Host Driver sending the parameter RAD_ACL[1:0] to the WRRADACL (55hH) command. The legend defines the symbols used: a rectangle for Command, a parallelogram for Parameter, an oval for Display, an arrow for Action, a rounded rectangle for Mode, and an oval with a tail for Sequential transfer.</p>																								

IMGEHCCTR (5800h) : Set_color_enhance

5800H		WRCE (set_color_enhance)																						
Inst/Para	R/W	Address		D15-8	D7	D6	D5	D4	D3	D2	D1	D0	HEX											
		MIPI	Other																					
WRCE	W	58h	5800h	x	0	0	0	0	0	SLR_EN	SLR_LEV EL1	SLR_LEV EL0	00											
Description	<table border="1"> <thead> <tr> <th>Bit</th> <th>Description</th> <th>Value</th> </tr> </thead> <tbody> <tr> <td>SLR_EN</td> <td>Sunlight Readable Enhancement Enable</td> <td>'0' : disable; '1': enable</td> </tr> <tr> <td>SLR_LEVEL[1:0]</td> <td>Sunlight Readable Enhancement Level</td> <td>0~2, low to high</td> </tr> </tbody> </table>												Bit	Description	Value	SLR_EN	Sunlight Readable Enhancement Enable	'0' : disable; '1': enable	SLR_LEVEL[1:0]	Sunlight Readable Enhancement Level	0~2, low to high			
	Bit	Description	Value																					
SLR_EN	Sunlight Readable Enhancement Enable	'0' : disable; '1': enable																						
SLR_LEVEL[1:0]	Sunlight Readable Enhancement Level	0~2, low to high																						
Restriction																								
Register Availability	<table border="1"> <thead> <tr> <th>Status</th> <th>Availability</th> </tr> </thead> <tbody> <tr> <td>Normal Mode On, Idle Mode Off, Sleep Out</td> <td>Yes</td> </tr> <tr> <td>Normal Mode On, Idle Mode On, Sleep Out</td> <td>Yes</td> </tr> <tr> <td>Partial Mode On, Idle Mode Off, Sleep Out</td> <td>Yes</td> </tr> <tr> <td>Partial Mode On, Idle Mode On, Sleep Out</td> <td>Yes</td> </tr> <tr> <td>Sleep In</td> <td>Yes</td> </tr> </tbody> </table>												Status	Availability	Normal Mode On, Idle Mode Off, Sleep Out	Yes	Normal Mode On, Idle Mode On, Sleep Out	Yes	Partial Mode On, Idle Mode Off, Sleep Out	Yes	Partial Mode On, Idle Mode On, Sleep Out	Yes	Sleep In	Yes
	Status	Availability																						
Normal Mode On, Idle Mode Off, Sleep Out	Yes																							
Normal Mode On, Idle Mode On, Sleep Out	Yes																							
Partial Mode On, Idle Mode Off, Sleep Out	Yes																							
Partial Mode On, Idle Mode On, Sleep Out	Yes																							
Sleep In	Yes																							
Flow Chart	<div style="border: 1px dashed black; padding: 10px;"> <p style="text-align: center;">Legend</p> <div style="display: flex; flex-direction: column; align-items: center;"> <div style="border: 1px solid black; width: 100px; height: 20px; margin-bottom: 5px;"></div> <div style="margin-bottom: 5px;">Command</div> <div style="border: 1px solid black; width: 100px; height: 20px; transform: rotate(-30deg); margin-bottom: 5px;"></div> <div style="margin-bottom: 5px;">Parameter</div> <div style="border: 1px solid black; width: 100px; height: 20px; border-radius: 10px; margin-bottom: 5px;"></div> <div style="margin-bottom: 5px;">Display</div> <div style="border: 1px solid black; width: 100px; height: 20px; border-radius: 10px; margin-bottom: 5px;"></div> <div style="margin-bottom: 5px;">Action</div> <div style="border: 1px solid black; width: 100px; height: 20px; border-radius: 10px; margin-bottom: 5px;"></div> <div style="margin-bottom: 5px;">Mode</div> <div style="border: 1px solid black; width: 100px; height: 40px; border-radius: 20px; margin-bottom: 5px; position: relative;"> <div style="position: absolute; top: -10px; left: 50%; transform: translate(-50%, -50%);">Sequential transfer</div> </div> </div> </div>																							

IMGEHCCTR (5900h) : Read_color_enhance

5900H		RDCE (set_color_enhance)																						
Inst/Para	R/W	Address		D15-8	D7	D6	D5	D4	D3	D2	D1	D0	HEX											
		MIPI	Other																					
RDCE	R	59h	5900h	x	0	0	0	0	0	SLR_EN	SLR_LEVEL1	SLR_LEVEL0	00											
Description	<table border="1"> <thead> <tr> <th>Bit</th> <th>Description</th> <th>Value</th> </tr> </thead> <tbody> <tr> <td>SLR_EN</td> <td>Sunlight Readable Enhancement Enable</td> <td>'0': disable; '1': enable</td> </tr> <tr> <td>SLR_LEVEL[1:0]</td> <td>Sunlight Readable Enhancement Level</td> <td>0~2, low to high</td> </tr> </tbody> </table>												Bit	Description	Value	SLR_EN	Sunlight Readable Enhancement Enable	'0': disable; '1': enable	SLR_LEVEL[1:0]	Sunlight Readable Enhancement Level	0~2, low to high			
	Bit	Description	Value																					
SLR_EN	Sunlight Readable Enhancement Enable	'0': disable; '1': enable																						
SLR_LEVEL[1:0]	Sunlight Readable Enhancement Level	0~2, low to high																						
Restriction																								
Register Availability	<table border="1"> <thead> <tr> <th>Status</th> <th>Availability</th> </tr> </thead> <tbody> <tr> <td>Normal Mode On, Idle Mode Off, Sleep Out</td> <td>Yes</td> </tr> <tr> <td>Normal Mode On, Idle Mode On, Sleep Out</td> <td>Yes</td> </tr> <tr> <td>Partial Mode On, Idle Mode Off, Sleep Out</td> <td>Yes</td> </tr> <tr> <td>Partial Mode On, Idle Mode On, Sleep Out</td> <td>Yes</td> </tr> <tr> <td>Sleep In</td> <td>Yes</td> </tr> </tbody> </table>												Status	Availability	Normal Mode On, Idle Mode Off, Sleep Out	Yes	Normal Mode On, Idle Mode On, Sleep Out	Yes	Partial Mode On, Idle Mode Off, Sleep Out	Yes	Partial Mode On, Idle Mode On, Sleep Out	Yes	Sleep In	Yes
	Status	Availability																						
Normal Mode On, Idle Mode Off, Sleep Out	Yes																							
Normal Mode On, Idle Mode On, Sleep Out	Yes																							
Partial Mode On, Idle Mode Off, Sleep Out	Yes																							
Partial Mode On, Idle Mode On, Sleep Out	Yes																							
Sleep In	Yes																							
Flow Chart	<div style="border: 1px dashed black; padding: 10px;"> <p>Legend</p> <ul style="list-style-type: none"> Command Parameter Display Action Mode Sequential transfer </div>																							

WRDISBV (6300h): Write HBM Display Brightness

6300H		WRDISBV																							
Inst/Para	R/W	Address		D15-8	D7	D6	D5	D4	D3	D2	D1	D0	HEX												
		MIPI	Other																						
WRHBMDIS BV	W	63h	6300h	x	DBV_HBM[7:0]							00													
Description	This command is used to adjust brightness value in HBM mode.																								
Restriction	The display supplier cannot use this command for tuning																								
Register Availability	<table border="1"> <thead> <tr> <th>Status</th> <th>Availability</th> </tr> </thead> <tbody> <tr> <td>Normal Mode On, Idle Mode Off, Sleep Out</td> <td>Yes</td> </tr> <tr> <td>Normal Mode On, Idle Mode On, Sleep Out</td> <td>Yes</td> </tr> <tr> <td>Partial Mode On, Idle Mode Off, Sleep Out</td> <td>Yes</td> </tr> <tr> <td>Partial Mode On, Idle Mode On, Sleep Out</td> <td>Yes</td> </tr> <tr> <td>Sleep In</td> <td>Yes</td> </tr> </tbody> </table>													Status	Availability	Normal Mode On, Idle Mode Off, Sleep Out	Yes	Normal Mode On, Idle Mode On, Sleep Out	Yes	Partial Mode On, Idle Mode Off, Sleep Out	Yes	Partial Mode On, Idle Mode On, Sleep Out	Yes	Sleep In	Yes
Status	Availability																								
Normal Mode On, Idle Mode Off, Sleep Out	Yes																								
Normal Mode On, Idle Mode On, Sleep Out	Yes																								
Partial Mode On, Idle Mode Off, Sleep Out	Yes																								
Partial Mode On, Idle Mode On, Sleep Out	Yes																								
Sleep In	Yes																								
Default	<table border="1"> <thead> <tr> <th>Status</th> <th>Default Value</th> </tr> </thead> <tbody> <tr> <td>Power On Sequence</td> <td>00h</td> </tr> <tr> <td>SW Reset</td> <td>00h</td> </tr> <tr> <td>HW Reset</td> <td>00h</td> </tr> </tbody> </table>													Status	Default Value	Power On Sequence	00h	SW Reset	00h	HW Reset	00h				
Status	Default Value																								
Power On Sequence	00h																								
SW Reset	00h																								
HW Reset	00h																								
Flow chart	<pre> graph TD A[WRDISBV (63h)] --> B[/Parameter DBV_HBM[7:0]/] B --> C([New Brightness Loaded]) </pre> <p>Legend</p> <ul style="list-style-type: none"> Command: Rectangle Parameter: Parallelogram Display: Oval Action: Arrow Mode: Rounded Rectangle Sequential transfer: Curved Arrow 																								

RDDISBV (6400h): Read HBM Display Brightness

5200H	RDDISBV																								
Inst/Para	R/W	Address		D15-8	D7	D6	D5	D4	D3	D2	D1	D0	HEX												
		MIPI	Other																						
RDHBMDISBV	R	64h	6400h	x	DBV_HBM[7:0]							00													
Description	This command returns brightness value in HBM mode.																								
Restriction	-																								
Register Availability	<table border="1"> <thead> <tr> <th>Status</th> <th>Availability</th> </tr> </thead> <tbody> <tr> <td>Normal Mode On, Idle Mode Off, Sleep Out</td> <td>Yes</td> </tr> <tr> <td>Normal Mode On, Idle Mode On, Sleep Out</td> <td>Yes</td> </tr> <tr> <td>Partial Mode On, Idle Mode Off, Sleep Out</td> <td>Yes</td> </tr> <tr> <td>Partial Mode On, Idle Mode On, Sleep Out</td> <td>Yes</td> </tr> <tr> <td>Sleep In</td> <td>Yes</td> </tr> </tbody> </table>													Status	Availability	Normal Mode On, Idle Mode Off, Sleep Out	Yes	Normal Mode On, Idle Mode On, Sleep Out	Yes	Partial Mode On, Idle Mode Off, Sleep Out	Yes	Partial Mode On, Idle Mode On, Sleep Out	Yes	Sleep In	Yes
Status	Availability																								
Normal Mode On, Idle Mode Off, Sleep Out	Yes																								
Normal Mode On, Idle Mode On, Sleep Out	Yes																								
Partial Mode On, Idle Mode Off, Sleep Out	Yes																								
Partial Mode On, Idle Mode On, Sleep Out	Yes																								
Sleep In	Yes																								
Default	<table border="1"> <thead> <tr> <th>Status</th> <th>Default Value</th> </tr> </thead> <tbody> <tr> <td>Power On Sequence</td> <td>00h</td> </tr> <tr> <td>SW Reset</td> <td>00h</td> </tr> <tr> <td>HW Reset</td> <td>00h</td> </tr> </tbody> </table>													Status	Default Value	Power On Sequence	00h	SW Reset	00h	HW Reset	00h				
Status	Default Value																								
Power On Sequence	00h																								
SW Reset	00h																								
HW Reset	00h																								
Flow Chart	<pre> sequenceDiagram participant Host participant Driver Host->>Driver: RDDISBV (64hH) Driver->>Host: Send parameter DBV_HBM[7:0] </pre>																								

HBM_Mode (6600h) : Set_HBM_Mode

		SetHbmMode																			
Inst/Para	R/W	Address		D15-8	D7	D6	D5	D4	D3	D2	D1	D0	HEX								
		MIPI	Other																		
SetHbmMode	W	66h	6600h	x	0	0	0	0	0	0	HBM_en	0	00								
Description	<p>HBM_en = 1, This command causes the display module to enter HBM mode (exit normal, idle and deep idle)</p> <p>HBM_en = 0, This command causes the display module to exit HBM mode (to normal mode)</p>																				
Restriction	under display area																				
Register Availability	<table border="1"> <thead> <tr> <th>Status</th> <th>Availability</th> </tr> </thead> <tbody> <tr> <td>Normal Mode On, Idle Mode On</td> <td>Yes</td> </tr> <tr> <td>Partial Mode On, Idle Mode On</td> <td>Yes</td> </tr> <tr> <td>Sleep In, Sleep Out</td> <td>No</td> </tr> </tbody> </table>													Status	Availability	Normal Mode On, Idle Mode On	Yes	Partial Mode On, Idle Mode On	Yes	Sleep In, Sleep Out	No
Status	Availability																				
Normal Mode On, Idle Mode On	Yes																				
Partial Mode On, Idle Mode On	Yes																				
Sleep In, Sleep Out	No																				

Deep_Idle_Mode (6700h) : Set_Deep Idle Mode

Inst/Para	R/W	Address		D15-8	D7	D6	D5	D4	D3	D2	D1	D0	HEX								
		MIPI	Other																		
SetDeepIdleMode	W	67h	6700h	x	0	0	0	0	0	0	0	DEEP_IDLE_EN	00								
Description	<p>Deep_Idle_en = 1, This command causes the display module to enter deep idle mode (exit normal, idle and HBM)</p> <p>Deep_Idle_en = 0, This command causes the display module to exit deep idle mode (to idle mode)</p>																				
Restriction	under display area																				
Register Availability	<table border="1"> <thead> <tr> <th>Status</th> <th>Availability</th> </tr> </thead> <tbody> <tr> <td>Normal Mode On, Idle Mode On</td> <td>Yes</td> </tr> <tr> <td>Partial Mode On, Idle Mode On</td> <td>Yes</td> </tr> <tr> <td>Sleep In, Sleep Out</td> <td>No</td> </tr> </tbody> </table>													Status	Availability	Normal Mode On, Idle Mode On	Yes	Partial Mode On, Idle Mode On	Yes	Sleep In, Sleep Out	No
Status	Availability																				
Normal Mode On, Idle Mode On	Yes																				
Partial Mode On, Idle Mode On	Yes																				
Sleep In, Sleep Out	No																				

COLSET (7000~7F00h): Interface Pixel Format Set

7000H ~ 7F00H		COLSET (Interface Pixel Format Set)											
Inst/Para	R/W	Address		D15-8	D7	D6	D5	D4	D3	D2	D1	D0	HEX
		MIPI	Other										
7000h	W	70h	7000h	x	R_0000[7:0]							00	
			7001h	x	G_0000[7:0]							00	
			7002h	x	B_0000[7:0]							00	
7100h	W	71h	7100h	x	R_0001[7:0]							00	
			7101h	x	G_0001[7:0]							00	
			7102h	x	B_0001[7:0]							FF	
7200h	W	72h	7200h	x	R_0010[7:0]							00	
			7201h	x	G_0010[7:0]							FF	
			7202h	x	B_0010[7:0]							00	
7300h	W	73h	7300h	x	R_0011[7:0]							00	
			7301h	x	G_0011[7:0]							FF	
			7302h	x	B_0011[7:0]							FF	
7400h	W	74h	7400h	x	R_0100[7:0]							FF	
			7401h	x	G_0100[7:0]							00	
			7402h	x	B_0100[7:0]							00	
7500h	W	75h	7500h	x	R_0101[7:0]							FF	
			7501h	x	G_0101[7:0]							00	
			7502h	x	B_0101[7:0]							FF	
7600h	W	76h	7600h	x	R_0110[7:0]							FF	
			7601h	x	G_0110[7:0]							FF	
			7602h	x	B_0110[7:0]							00	
7700h	W	77h	7700h	x	R_0111[7:0]							FF	
			7701h	x	G_0111[7:0]							FF	
			7702h	x	B_0111[7:0]							FF	
7800h	W	78h	7800h	x	R_1000[7:0]							00	
			7801h	x	G_1000[7:0]							00	
			7802h	x	B_1000[7:0]							00	
7900h	W	79h	7900h	x	R_1001[7:0]							00	
			7901h	x	G_1001[7:0]							00	
			7902h	x	B_1001[7:0]							FF	
7A00h	W	7Ah	7A00h	x	R_1010[7:0]							00	

			7A01h	x	G_1010[7:0]	FF
			7A02h	x	B_1010[7:0]	00
7B00h	W	7Bh	7B00h	x	R_1011[7:0]	00
			7B01h	x	G_1011[7:0]	FF
			7B02h	x	B_1011[7:0]	FF
7C00h	W	7Ch	7C00h	x	R_1100[7:0]	FF
			7C01h	x	G_1100[7:0]	00
			7C02h	x	B_1100[7:0]	00
7D00h	W	7Dh	7D00h	x	R_1101[7:0]	FF
			7D01h	x	G_1101[7:0]	00
			7D02h	x	B_1101[7:0]	FF
7E00h	W	7Eh	7E00h	x	R_1110[7:0]	FF
			7E01h	x	G_1110[7:0]	FF
			7E02h	x	B_1110[7:0]	00
7F00h	W	7Fh	7F00h	x	R_1111[7:0]	FF
			7F01h	x	G_1111[7:0]	FF
			7F02h	x	B_1111[7:0]	FF

CONFIDENTIAL

Description	This command set the 1-1-1 color format map directly to 24 bits by CMD 7000h-7F00h																						
	RGB111 color mapping	R[7:0]	G[7:0]	B[7:0]																			
	0000 (70h)	R_0000[7:0]	G_0000[7:0]	B_0000[7:0]																			
	0001 (71h)	R_0001[7:0]	G_0001[7:0]	B_0001[7:0]																			
	0010 (72h)	R_0010[7:0]	G_0010[7:0]	B_0010[7:0]																			
	0011 (73h)	R_0011[7:0]	G_0011[7:0]	B_0011[7:0]																			
	0100 (74h)	R_0100[7:0]	G_0100[7:0]	B_0100[7:0]																			
	0101 (75h)	R_0101[7:0]	G_0101[7:0]	B_0101[7:0]																			
	0110 (76h)	R_0110[7:0]	G_0110[7:0]	B_0110[7:0]																			
	0111 (77h)	R_0111[7:0]	G_0111[7:0]	B_0111[7:0]																			
	1000 (78h)	R_1000[7:0]	G_1000[7:0]	B_1000[7:0]																			
	1001 (79h)	R_1001[7:0]	G_1001[7:0]	B_1001[7:0]																			
	1010 (7Ah)	R_1010[7:0]	G_1010[7:0]	B_1010[7:0]																			
	1011 (7Bh)	R_1011[7:0]	G_1011[7:0]	B_1011[7:0]																			
	1100 (7Ch)	R_1100[7:0]	G_1100[7:0]	B_1100[7:0]																			
1101 (7Dh)	R_1101[7:0]	G_1101[7:0]	B_1101[7:0]																				
1110 (7Eh)	R_1110[7:0]	G_1110[7:0]	B_1110[7:0]																				
1111 (7Fh)	R_1111[7:0]	G_1111[7:0]	B_1111[7:0]																				
Restriction																							
Register Availability	<table border="1"> <thead> <tr> <th>Status</th> <th>Availability</th> </tr> </thead> <tbody> <tr> <td>Normal Mode On, Idle Mode Off, Sleep Out</td> <td>Yes</td> </tr> <tr> <td>Normal Mode On, Idle Mode On, Sleep Out</td> <td>Yes</td> </tr> <tr> <td>Partial Mode On, Idle Mode Off, Sleep Out</td> <td>Yes</td> </tr> <tr> <td>Partial Mode On, Idle Mode On, Sleep Out</td> <td>Yes</td> </tr> <tr> <td>Sleep In</td> <td>Yes</td> </tr> </tbody> </table>				Status	Availability	Normal Mode On, Idle Mode Off, Sleep Out	Yes	Normal Mode On, Idle Mode On, Sleep Out	Yes	Partial Mode On, Idle Mode Off, Sleep Out	Yes	Partial Mode On, Idle Mode On, Sleep Out	Yes	Sleep In	Yes							
Status	Availability																						
Normal Mode On, Idle Mode Off, Sleep Out	Yes																						
Normal Mode On, Idle Mode On, Sleep Out	Yes																						
Partial Mode On, Idle Mode Off, Sleep Out	Yes																						
Partial Mode On, Idle Mode On, Sleep Out	Yes																						
Sleep In	Yes																						
Default	<p>Example :</p> <table border="1"> <thead> <tr> <th rowspan="2">Status</th> <th colspan="3">Default Value</th> </tr> <tr> <th>R_0000[7:0]</th> <th>G_0000[7:0]</th> <th>B_0000[7:0]</th> </tr> </thead> <tbody> <tr> <td>Power On Sequence</td> <td>00h</td> <td>00h</td> <td>00h</td> </tr> <tr> <td>SW Reset</td> <td>00h</td> <td>00h</td> <td>00h</td> </tr> <tr> <td>HW Reset</td> <td>00h</td> <td>00h</td> <td>00h</td> </tr> </tbody> </table>				Status	Default Value			R_0000[7:0]	G_0000[7:0]	B_0000[7:0]	Power On Sequence	00h	00h	00h	SW Reset	00h	00h	00h	HW Reset	00h	00h	00h
Status	Default Value																						
	R_0000[7:0]	G_0000[7:0]	B_0000[7:0]																				
Power On Sequence	00h	00h	00h																				
SW Reset	00h	00h	00h																				
HW Reset	00h	00h	00h																				

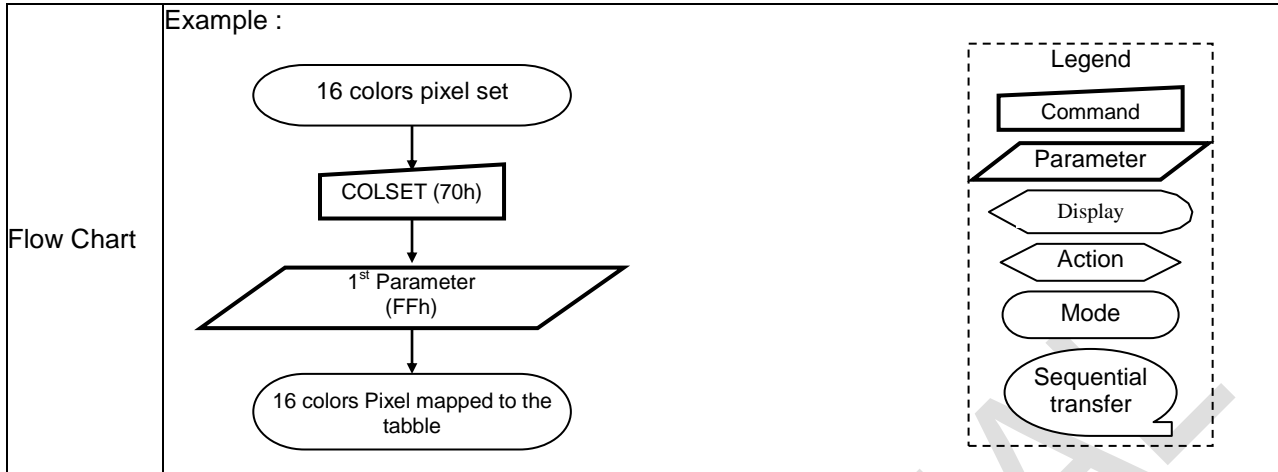

CONFIDENTIAL

COLOPT (8000h): Interface Pixel Format Option

8000H		COLOPT (Interface Pixel Format Option)																																																																																																																																																																																																																	
Inst/Para	R/W	Address		D15-8	D7	D6	D5	D4	D3	D2	D1	D0	HEX																																																																																																																																																																																																						
		MIPI	Other																																																																																																																																																																																																																
COLSET	W	80h	8000h	x	x	RGB11_opt	x	x	RGB4bit_en	gray256_color[2]	gray256_color[1]	gray256_color[0]	07																																																																																																																																																																																																						
Description	<p>This command sets the 1-1-1/256 gray color format option used by SPI interface.</p> <p>RGB11_opt = 0 (80h-B6): Supporting in IFPF[2:0]=011 case setting by 3A00h (interface pixel format is SPI 1-1-1).</p> <table border="1"> <thead> <tr> <th>RGB 1-1-1 Bit</th> <th>DCX</th> <th>D[7]</th> <th>D[6]</th> <th>D[5]</th> <th>D[4]</th> <th>D[3]</th> <th>D[2]</th> <th>D[1]</th> <th>D[0]</th> <th>Note</th> </tr> </thead> <tbody> <tr> <td>CMDWR</td> <td>0</td> <td>0</td> <td>0</td> <td>0</td> <td>0</td> <td>0</td> <td>0</td> <td>0</td> <td>0</td> <td>0x2C for GRAM Write</td> </tr> <tr> <td>1st RAM Data Write</td> <td>1</td> <td>x</td> <td>x</td> <td>R1[0]</td> <td>G1[0]</td> <td>B1[0]</td> <td>R2[0]</td> <td>G2[0]</td> <td>B2[0]</td> <td>1,2 pixel Data Write</td> </tr> <tr> <td>2nd RAM Data Write</td> <td>1</td> <td>x</td> <td>x</td> <td>R3[0]</td> <td>G3[0]</td> <td>B3[0]</td> <td>R4[0]</td> <td>G4[0]</td> <td>B4[0]</td> <td>3,4 pixel Data Write</td> </tr> <tr> <td>3rd RAM Data Write</td> <td>1</td> <td>x</td> <td>x</td> <td>R5[0]</td> <td>G5[0]</td> <td>B5[0]</td> <td>R6[0]</td> <td>G6[0]</td> <td>B6[0]</td> <td>5,6 pixel Data Write</td> </tr> <tr> <td>So on...</td> <td></td> <td></td> <td></td> <td></td> <td></td> <td></td> <td></td> <td></td> <td></td> <td></td> </tr> </tbody> </table> <p>RGB11_opt = 1 (80h-B6): Supporting in IFPF[2:0]=011 case setting by 3A00h (interface pixel format is SPI 1-1-1).</p> <table border="1"> <thead> <tr> <th>RGB 1-1-1 Bit</th> <th>DCX</th> <th>D[7]</th> <th>D[6]</th> <th>D[5]</th> <th>D[4]</th> <th>D[3]</th> <th>D[2]</th> <th>D[1]</th> <th>D[0]</th> <th>Note</th> </tr> </thead> <tbody> <tr> <td>CMDWR</td> <td>0</td> <td>0</td> <td>0</td> <td>0</td> <td>0</td> <td>0</td> <td>0</td> <td>0</td> <td>0</td> <td>0x2C for GRAM Write</td> </tr> <tr> <td>1st RAM Data Write</td> <td>1</td> <td>x</td> <td>R1[0]</td> <td>G1[0]</td> <td>B1[0]</td> <td>x</td> <td>R2[0]</td> <td>G2[0]</td> <td>B2[0]</td> <td>1,2 Pixel Data Write</td> </tr> <tr> <td>2nd RAM Data Write</td> <td>1</td> <td>x</td> <td>R3[0]</td> <td>G3[0]</td> <td>B3[0]</td> <td>x</td> <td>R4[0]</td> <td>G4[0]</td> <td>B4[0]</td> <td>3,4 Pixel Data Write</td> </tr> <tr> <td>3rd RAM Data Write</td> <td>1</td> <td>x</td> <td>R5[0]</td> <td>G5[0]</td> <td>B5[0]</td> <td>x</td> <td>R6[0]</td> <td>G6[0]</td> <td>B6[0]</td> <td>5,6 Pixel Data Write</td> </tr> <tr> <td>So on...</td> <td></td> <td></td> <td></td> <td></td> <td></td> <td></td> <td></td> <td></td> <td></td> <td></td> </tr> </tbody> </table> <p>RGB4bit_en = 0 (80h-B3): Supporting in IFPF[2:0]=011 case setting by 3A00h (interface pixel format is SPI 1-1-1). Three bits per pixel formats map directly to 24bits by CMD 7000h-7700h</p> <table border="1"> <thead> <tr> <th>RGB 1-1-1 Bit</th> <th>DCX</th> <th>D[7]</th> <th>D[6]</th> <th>D[5]</th> <th>D[4]</th> <th>D[3]</th> <th>D[2]</th> <th>D[1]</th> <th>D[0]</th> <th>Note</th> </tr> </thead> <tbody> <tr> <td>CMDWR</td> <td>0</td> <td>0</td> <td>0</td> <td>0</td> <td>0</td> <td>0</td> <td>0</td> <td>0</td> <td>0</td> <td>0x2C for GRAM Write</td> </tr> <tr> <td>1st RAM Data Write</td> <td>1</td> <td>x</td> <td>x</td> <td>P1[2]</td> <td>P1[1]</td> <td>P1[0]</td> <td>P2[2]</td> <td>P2[1]</td> <td>P2[0]</td> <td>1,2 Pixel Data Write</td> </tr> <tr> <td>2nd RAM Data Write</td> <td>1</td> <td>x</td> <td>x</td> <td>P3[2]</td> <td>P3[1]</td> <td>P3[0]</td> <td>P4[2]</td> <td>P4[1]</td> <td>P4[0]</td> <td>3,4 Pixel Data Write</td> </tr> <tr> <td>3rd RAM Data Write</td> <td>1</td> <td>x</td> <td>x</td> <td>P5[2]</td> <td>P5[1]</td> <td>P5[0]</td> <td>P6[2]</td> <td>P6[1]</td> <td>P6[0]</td> <td>5,6 Pixel Data Write</td> </tr> <tr> <td>So on...</td> <td></td> <td></td> <td></td> <td></td> <td></td> <td></td> <td></td> <td></td> <td></td> <td></td> </tr> </tbody> </table> <p>Example: P1[2:0] = 3'b101 = { R_0101[7:0], G_0101[7:0], B_0101[7:0] } CMD 7500h-7502h</p>													RGB 1-1-1 Bit	DCX	D[7]	D[6]	D[5]	D[4]	D[3]	D[2]	D[1]	D[0]	Note	CMDWR	0	0	0	0	0	0	0	0	0	0x2C for GRAM Write	1st RAM Data Write	1	x	x	R1[0]	G1[0]	B1[0]	R2[0]	G2[0]	B2[0]	1,2 pixel Data Write	2nd RAM Data Write	1	x	x	R3[0]	G3[0]	B3[0]	R4[0]	G4[0]	B4[0]	3,4 pixel Data Write	3rd RAM Data Write	1	x	x	R5[0]	G5[0]	B5[0]	R6[0]	G6[0]	B6[0]	5,6 pixel Data Write	So on...											RGB 1-1-1 Bit	DCX	D[7]	D[6]	D[5]	D[4]	D[3]	D[2]	D[1]	D[0]	Note	CMDWR	0	0	0	0	0	0	0	0	0	0x2C for GRAM Write	1st RAM Data Write	1	x	R1[0]	G1[0]	B1[0]	x	R2[0]	G2[0]	B2[0]	1,2 Pixel Data Write	2nd RAM Data Write	1	x	R3[0]	G3[0]	B3[0]	x	R4[0]	G4[0]	B4[0]	3,4 Pixel Data Write	3rd RAM Data Write	1	x	R5[0]	G5[0]	B5[0]	x	R6[0]	G6[0]	B6[0]	5,6 Pixel Data Write	So on...											RGB 1-1-1 Bit	DCX	D[7]	D[6]	D[5]	D[4]	D[3]	D[2]	D[1]	D[0]	Note	CMDWR	0	0	0	0	0	0	0	0	0	0x2C for GRAM Write	1st RAM Data Write	1	x	x	P1[2]	P1[1]	P1[0]	P2[2]	P2[1]	P2[0]	1,2 Pixel Data Write	2nd RAM Data Write	1	x	x	P3[2]	P3[1]	P3[0]	P4[2]	P4[1]	P4[0]	3,4 Pixel Data Write	3rd RAM Data Write	1	x	x	P5[2]	P5[1]	P5[0]	P6[2]	P6[1]	P6[0]	5,6 Pixel Data Write	So on...										
	RGB 1-1-1 Bit	DCX	D[7]	D[6]	D[5]	D[4]	D[3]	D[2]	D[1]	D[0]	Note																																																																																																																																																																																																								
	CMDWR	0	0	0	0	0	0	0	0	0	0x2C for GRAM Write																																																																																																																																																																																																								
	1st RAM Data Write	1	x	x	R1[0]	G1[0]	B1[0]	R2[0]	G2[0]	B2[0]	1,2 pixel Data Write																																																																																																																																																																																																								
	2nd RAM Data Write	1	x	x	R3[0]	G3[0]	B3[0]	R4[0]	G4[0]	B4[0]	3,4 pixel Data Write																																																																																																																																																																																																								
	3rd RAM Data Write	1	x	x	R5[0]	G5[0]	B5[0]	R6[0]	G6[0]	B6[0]	5,6 pixel Data Write																																																																																																																																																																																																								
	So on...																																																																																																																																																																																																																		
	RGB 1-1-1 Bit	DCX	D[7]	D[6]	D[5]	D[4]	D[3]	D[2]	D[1]	D[0]	Note																																																																																																																																																																																																								
	CMDWR	0	0	0	0	0	0	0	0	0	0x2C for GRAM Write																																																																																																																																																																																																								
	1st RAM Data Write	1	x	R1[0]	G1[0]	B1[0]	x	R2[0]	G2[0]	B2[0]	1,2 Pixel Data Write																																																																																																																																																																																																								
	2nd RAM Data Write	1	x	R3[0]	G3[0]	B3[0]	x	R4[0]	G4[0]	B4[0]	3,4 Pixel Data Write																																																																																																																																																																																																								
	3rd RAM Data Write	1	x	R5[0]	G5[0]	B5[0]	x	R6[0]	G6[0]	B6[0]	5,6 Pixel Data Write																																																																																																																																																																																																								
	So on...																																																																																																																																																																																																																		
	RGB 1-1-1 Bit	DCX	D[7]	D[6]	D[5]	D[4]	D[3]	D[2]	D[1]	D[0]	Note																																																																																																																																																																																																								
	CMDWR	0	0	0	0	0	0	0	0	0	0x2C for GRAM Write																																																																																																																																																																																																								
1st RAM Data Write	1	x	x	P1[2]	P1[1]	P1[0]	P2[2]	P2[1]	P2[0]	1,2 Pixel Data Write																																																																																																																																																																																																									
2nd RAM Data Write	1	x	x	P3[2]	P3[1]	P3[0]	P4[2]	P4[1]	P4[0]	3,4 Pixel Data Write																																																																																																																																																																																																									
3rd RAM Data Write	1	x	x	P5[2]	P5[1]	P5[0]	P6[2]	P6[1]	P6[0]	5,6 Pixel Data Write																																																																																																																																																																																																									
So on...																																																																																																																																																																																																																			

Description	<p>RGB4bit_en = 1(80h-B3): Supporting in IFPF[2:0]=011 case setting by 3A00h (interface pixel format is SPI 1-1-1). Four bits per pixel formats map directly to 24bits by CMD 7000h-7F00h</p> <table border="1"> <thead> <tr> <th>RGB 1-1-1 Bit</th> <th>DCX</th> <th>D[7]</th> <th>D[6]</th> <th>D[5]</th> <th>D[4]</th> <th>D[3]</th> <th>D[2]</th> <th>D[1]</th> <th>D[0]</th> <th>Note</th> </tr> </thead> <tbody> <tr> <td>CMDWR</td> <td>0</td> <td>0</td> <td>0</td> <td>0</td> <td>0</td> <td>0</td> <td>0</td> <td>0</td> <td>0</td> <td>0x2C for GRAM Write</td> </tr> <tr> <td>1st RAM Data Write</td> <td>1</td> <td>P1[3]</td> <td>P1[2]</td> <td>P1[1]</td> <td>P1[0]</td> <td>P2[3]</td> <td>P2[2]</td> <td>P2[1]</td> <td>P2[0]</td> <td>1,2 Pixel Data Write</td> </tr> <tr> <td>2nd RAM Data Write</td> <td>1</td> <td>P3[3]</td> <td>P3[2]</td> <td>P3[1]</td> <td>P3[0]</td> <td>P4[3]</td> <td>P4[2]</td> <td>P4[1]</td> <td>P4[0]</td> <td>3,4 Pixel Data Write</td> </tr> <tr> <td>3rd RAM Data Write</td> <td>1</td> <td>P5[3]</td> <td>P5[2]</td> <td>P5[1]</td> <td>P5[0]</td> <td>P6[3]</td> <td>P6[2]</td> <td>P6[1]</td> <td>P6[0]</td> <td>5,6 Pixel Data Write</td> </tr> <tr> <td>So on...</td> <td></td> <td></td> <td></td> <td></td> <td></td> <td></td> <td></td> <td></td> <td></td> <td></td> </tr> </tbody> </table> <p>Example: P1[3:0] = 4'b1101 = { R_1101[7:0], G_1101[7:0], B_1101[7:0] } CMD 7D00h-7D02h</p> <p>gray256_color(80h-B[2:0]): Supporting in IFPF[2:0]=001 case setting by 3A00h (interface pixel format is SPI 256 Gray). This command sets the valid red, green and blue 256 grayscale</p> <table border="1"> <thead> <tr> <th>gray256_color[2:0]</th> <th>Red grayscale</th> <th>Green grayscale</th> <th>Blue grayscale</th> </tr> </thead> <tbody> <tr> <td>000</td> <td>00000000</td> <td>00000000</td> <td>00000000</td> </tr> <tr> <td>001</td> <td>00000000</td> <td>00000000</td> <td>P[7:0]</td> </tr> <tr> <td>010</td> <td>00000000</td> <td>P[7:0]</td> <td>00000000</td> </tr> <tr> <td>011</td> <td>00000000</td> <td>P[7:0]</td> <td>P[7:0]</td> </tr> <tr> <td>100</td> <td>P[7:0]</td> <td>00000000</td> <td>00000000</td> </tr> <tr> <td>101</td> <td>P[7:0]</td> <td>00000000</td> <td>P[7:0]</td> </tr> <tr> <td>110</td> <td>P[7:0]</td> <td>P[7:0]</td> <td>00000000</td> </tr> <tr> <td>111</td> <td>P[7:0]</td> <td>P[7:0]</td> <td>P[7:0]</td> </tr> </tbody> </table>										RGB 1-1-1 Bit	DCX	D[7]	D[6]	D[5]	D[4]	D[3]	D[2]	D[1]	D[0]	Note	CMDWR	0	0	0	0	0	0	0	0	0	0x2C for GRAM Write	1st RAM Data Write	1	P1[3]	P1[2]	P1[1]	P1[0]	P2[3]	P2[2]	P2[1]	P2[0]	1,2 Pixel Data Write	2nd RAM Data Write	1	P3[3]	P3[2]	P3[1]	P3[0]	P4[3]	P4[2]	P4[1]	P4[0]	3,4 Pixel Data Write	3rd RAM Data Write	1	P5[3]	P5[2]	P5[1]	P5[0]	P6[3]	P6[2]	P6[1]	P6[0]	5,6 Pixel Data Write	So on...											gray256_color[2:0]	Red grayscale	Green grayscale	Blue grayscale	000	00000000	00000000	00000000	001	00000000	00000000	P[7:0]	010	00000000	P[7:0]	00000000	011	00000000	P[7:0]	P[7:0]	100	P[7:0]	00000000	00000000	101	P[7:0]	00000000	P[7:0]	110	P[7:0]	P[7:0]	00000000	111	P[7:0]	P[7:0]	P[7:0]
	RGB 1-1-1 Bit	DCX	D[7]	D[6]	D[5]	D[4]	D[3]	D[2]	D[1]	D[0]	Note																																																																																																					
CMDWR	0	0	0	0	0	0	0	0	0	0x2C for GRAM Write																																																																																																						
1st RAM Data Write	1	P1[3]	P1[2]	P1[1]	P1[0]	P2[3]	P2[2]	P2[1]	P2[0]	1,2 Pixel Data Write																																																																																																						
2nd RAM Data Write	1	P3[3]	P3[2]	P3[1]	P3[0]	P4[3]	P4[2]	P4[1]	P4[0]	3,4 Pixel Data Write																																																																																																						
3rd RAM Data Write	1	P5[3]	P5[2]	P5[1]	P5[0]	P6[3]	P6[2]	P6[1]	P6[0]	5,6 Pixel Data Write																																																																																																						
So on...																																																																																																																
gray256_color[2:0]	Red grayscale	Green grayscale	Blue grayscale																																																																																																													
000	00000000	00000000	00000000																																																																																																													
001	00000000	00000000	P[7:0]																																																																																																													
010	00000000	P[7:0]	00000000																																																																																																													
011	00000000	P[7:0]	P[7:0]																																																																																																													
100	P[7:0]	00000000	00000000																																																																																																													
101	P[7:0]	00000000	P[7:0]																																																																																																													
110	P[7:0]	P[7:0]	00000000																																																																																																													
111	P[7:0]	P[7:0]	P[7:0]																																																																																																													
Restriction																																																																																																																

Register Availability	<table border="1"> <thead> <tr> <th>Status</th> <th>Availability</th> </tr> </thead> <tbody> <tr> <td>Normal Mode On, Idle Mode Off, Sleep Out</td> <td>Yes</td> </tr> <tr> <td>Normal Mode On, Idle Mode On, Sleep Out</td> <td>Yes</td> </tr> <tr> <td>Partial Mode On, Idle Mode Off, Sleep Out</td> <td>Yes</td> </tr> <tr> <td>Partial Mode On, Idle Mode On, Sleep Out</td> <td>Yes</td> </tr> <tr> <td>Sleep In</td> <td>Yes</td> </tr> </tbody> </table>	Status	Availability	Normal Mode On, Idle Mode Off, Sleep Out	Yes	Normal Mode On, Idle Mode On, Sleep Out	Yes	Partial Mode On, Idle Mode Off, Sleep Out	Yes	Partial Mode On, Idle Mode On, Sleep Out	Yes	Sleep In	Yes
Status	Availability												
Normal Mode On, Idle Mode Off, Sleep Out	Yes												
Normal Mode On, Idle Mode On, Sleep Out	Yes												
Partial Mode On, Idle Mode Off, Sleep Out	Yes												
Partial Mode On, Idle Mode On, Sleep Out	Yes												
Sleep In	Yes												
Default	<table border="1"> <thead> <tr> <th>Status</th> <th>Default Value</th> </tr> </thead> <tbody> <tr> <td>Power On Sequence</td> <td>07h</td> </tr> <tr> <td>SW Reset</td> <td>07h</td> </tr> <tr> <td>HW Reset</td> <td>07h</td> </tr> </tbody> </table>	Status	Default Value	Power On Sequence	07h	SW Reset	07h	HW Reset	07h				
Status	Default Value												
Power On Sequence	07h												
SW Reset	07h												
HW Reset	07h												
Flow chart	<p>Example :</p> <pre> graph TD A([8 colors Pixel Mode]) --> B[COLOPT (80h)] B --> C[/1st Parameter (0Fh)/] C --> D([16 colors Pixel Mode]) </pre> <p>Legend</p> <ul style="list-style-type: none"> Command: Rectangle Parameter: Parallelogram Display: Oval Action: Arrowhead Mode: Oval Sequential transfer: Oval with tail 												

RDDDBS(A100h) : Read_DDB_Start

A100H		RDDDBS(Read_DDB_Start)																									
Inst/Para	R/W	Address		D15-8	D7	D6	D5	D4	D3	D2	D1	D0	HEX														
		MIPI	Other																								
RDDDBS	R	A1h	A100h	x	SID[7]	SID [6]	SID [5]	SID [4]	SID [3]	SID [2]	SID [1]	SID [0]	D0														
			A101h	x	SID[15]	SID[14]	SID[13]	SID[12]	SID[11]	SID[10]	SID[9]	SID[8]	01														
			A102h	x	MID[7]	MID[6]	MID[5]	MID[4]	MID[3]	MID[2]	MID[1]	MID[0]	80														
			A103h	x	MID[15]	MID[14]	MID[13]	MID[12]	MID[11]	MID[10]	MID[9]	MID[8]	90														
			A104h	x	1	1	1	1	1	1	1	1	1	FF													
Description	1 st 2 nd 3 rd 4 th 5 th	parameter: Supplier ID code parameter: Supplier ID code parameter: Module ID parameter: Module ID Exit code (FFh).																									
Restriction																											
Register Availability	<table border="1"> <thead> <tr> <th>Status</th> <th>Availability</th> </tr> </thead> <tbody> <tr> <td>Normal Mode On, Idle Mode Off, Sleep Out</td> <td>Yes</td> </tr> <tr> <td>Normal Mode On, Idle Mode On, Sleep Out</td> <td>Yes</td> </tr> <tr> <td>Partial Mode On, Idle Mode Off, Sleep Out</td> <td>Yes</td> </tr> <tr> <td>Partial Mode On, Idle Mode On, Sleep Out</td> <td>Yes</td> </tr> <tr> <td>Sleep In</td> <td>Yes</td> </tr> </tbody> </table>													Status	Availability	Normal Mode On, Idle Mode Off, Sleep Out	Yes	Normal Mode On, Idle Mode On, Sleep Out	Yes	Partial Mode On, Idle Mode Off, Sleep Out	Yes	Partial Mode On, Idle Mode On, Sleep Out	Yes	Sleep In	Yes		
Status	Availability																										
Normal Mode On, Idle Mode Off, Sleep Out	Yes																										
Normal Mode On, Idle Mode On, Sleep Out	Yes																										
Partial Mode On, Idle Mode Off, Sleep Out	Yes																										
Partial Mode On, Idle Mode On, Sleep Out	Yes																										
Sleep In	Yes																										
Default	<table border="1"> <thead> <tr> <th rowspan="2">Status</th> <th colspan="2">Default Value</th> </tr> <tr> <th>After MTP</th> <th>Before MTP</th> </tr> </thead> <tbody> <tr> <td>Power On Sequence</td> <td>MTP Value</td> <td>01h, D0h, 90h, 60h, FFh</td> </tr> <tr> <td>SW Reset</td> <td>MTP Value</td> <td>01h, D0h, 90h, 60h, FFh</td> </tr> <tr> <td>HW Reset</td> <td>MTP Value</td> <td>01h, D0h, 90h, 60h, FFh</td> </tr> </tbody> </table>													Status	Default Value		After MTP	Before MTP	Power On Sequence	MTP Value	01h, D0h, 90h, 60h, FFh	SW Reset	MTP Value	01h, D0h, 90h, 60h, FFh	HW Reset	MTP Value	01h, D0h, 90h, 60h, FFh
Status	Default Value																										
	After MTP	Before MTP																									
Power On Sequence	MTP Value	01h, D0h, 90h, 60h, FFh																									
SW Reset	MTP Value	01h, D0h, 90h, 60h, FFh																									
HW Reset	MTP Value	01h, D0h, 90h, 60h, FFh																									

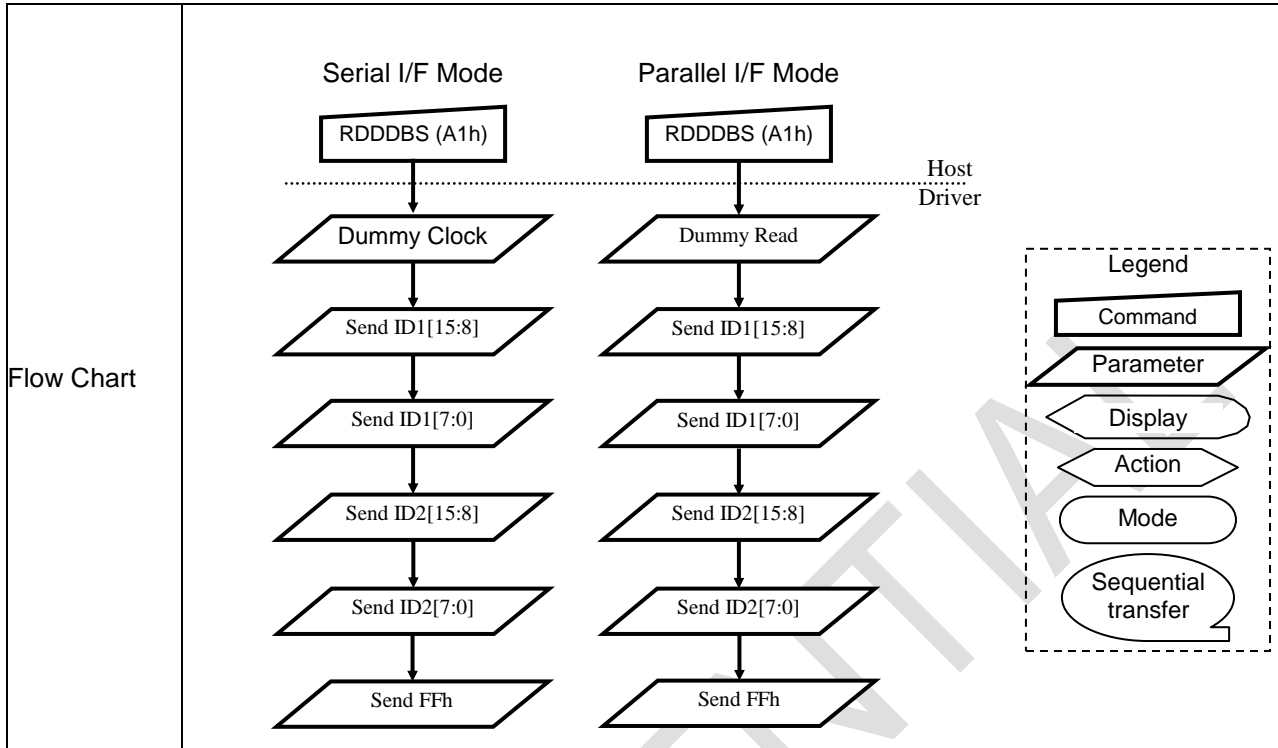

RDDDBC(A800h) : Read DDB Continous

A800H		RDDDBC																									
Inst/Para	R/W	Address		D15-8	D7	D6	D5	D4	D3	D2	D1	D0	HEX														
		MIPI	Other																								
RDDDBC	R	A8h	A800h	x	SID[7]	SID [6]	SID [5]	SID [4]	SID [3]	SID [2]	SID [1]	SID [0]	D0														
			A801h	x	SID[15]	SID[14]	SID[13]	SID[12]	SID[11]	SID[10]	SID[9]	SID[8]	01														
			A802h	x	MID[7]	MID[6]	MID[5]	MID[4]	MID[3]	MID[2]	MID[1]	MID[0]	80														
			A803h	x	MID[15]	MID[14]	MID[13]	MID[12]	MID[11]	MID[10]	MID[9]	MID[8]	90														
			A804h	x	1	1	1	1	1	1	1	1	1	FF													
Description	<p>This command returns the supplier identification and display module mode/revision information from the point where RDDDBS command was interrupted by an other command. <i>Note: Parameter 0xFF is an "Exit Code", this means that there is no more data in the DDB block.</i> <i>Note: For use example,</i></p> <ol style="list-style-type: none"> 1. Set maximum return packet size=3 2. Read 0xA1, return 3 bytes SID[7:0], SID[15:8], MID[7:0] 3. Read 0xA8, return 2 bytes MID[15:8],RID[7:0], RID[15:8] and 0xFF 																										
Restriction	<p>A Read DDB Start command (RDDDBS) should be executed at least once before a Read DDB Continue command (RDDDBC) to define the read location. Otherwise, data read with a Read DDB Continue command is undefined.</p>																										
Register Availability	<table border="1"> <thead> <tr> <th>Status</th> <th>Availability</th> </tr> </thead> <tbody> <tr> <td>Normal Mode On, Idle Mode Off, Sleep Out</td> <td>Yes</td> </tr> <tr> <td>Normal Mode On, Idle Mode On, Sleep Out</td> <td>Yes</td> </tr> <tr> <td>Partial Mode On, Idle Mode Off, Sleep Out</td> <td>Yes</td> </tr> <tr> <td>Partial Mode On, Idle Mode On, Sleep Out</td> <td>Yes</td> </tr> <tr> <td>Sleep In</td> <td>Yes</td> </tr> </tbody> </table>													Status	Availability	Normal Mode On, Idle Mode Off, Sleep Out	Yes	Normal Mode On, Idle Mode On, Sleep Out	Yes	Partial Mode On, Idle Mode Off, Sleep Out	Yes	Partial Mode On, Idle Mode On, Sleep Out	Yes	Sleep In	Yes		
Status	Availability																										
Normal Mode On, Idle Mode Off, Sleep Out	Yes																										
Normal Mode On, Idle Mode On, Sleep Out	Yes																										
Partial Mode On, Idle Mode Off, Sleep Out	Yes																										
Partial Mode On, Idle Mode On, Sleep Out	Yes																										
Sleep In	Yes																										
Default	<table border="1"> <thead> <tr> <th rowspan="2">Status</th> <th colspan="2">Default Value</th> </tr> <tr> <th>After MTP</th> <th>Before MTP</th> </tr> </thead> <tbody> <tr> <td>Power On Sequence</td> <td>MTP Value</td> <td>01h, D0h, 90h, 60h, FFh</td> </tr> <tr> <td>SW Reset</td> <td>MTP Value</td> <td>01h, D0h, 90h, 60h, FFh</td> </tr> <tr> <td>HW Reset</td> <td>MTP Value</td> <td>01h, D0h, 90h, 60h, FFh</td> </tr> </tbody> </table>													Status	Default Value		After MTP	Before MTP	Power On Sequence	MTP Value	01h, D0h, 90h, 60h, FFh	SW Reset	MTP Value	01h, D0h, 90h, 60h, FFh	HW Reset	MTP Value	01h, D0h, 90h, 60h, FFh
Status	Default Value																										
	After MTP	Before MTP																									
Power On Sequence	MTP Value	01h, D0h, 90h, 60h, FFh																									
SW Reset	MTP Value	01h, D0h, 90h, 60h, FFh																									
HW Reset	MTP Value	01h, D0h, 90h, 60h, FFh																									

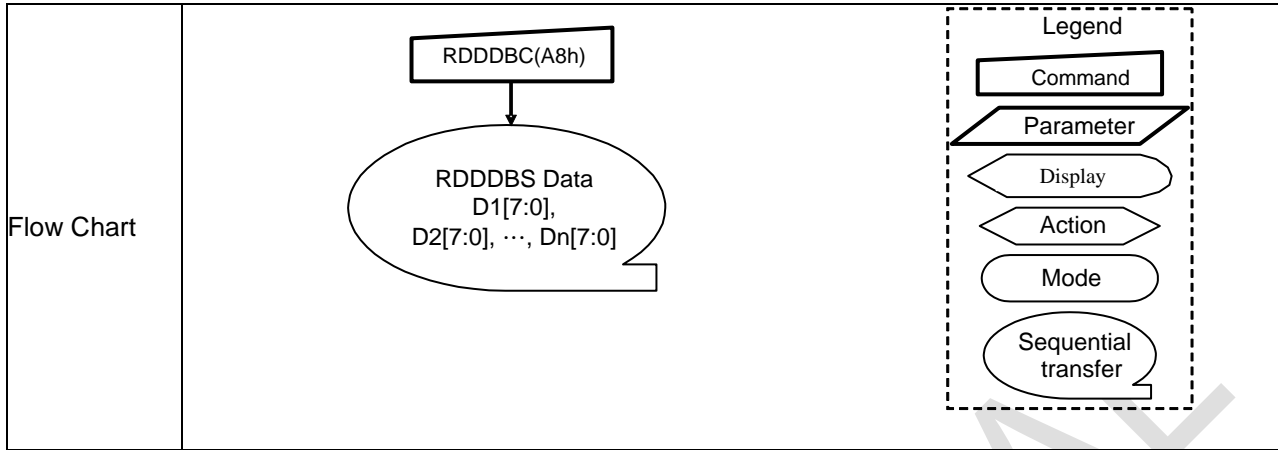

CONFIDENTIAL

RDFCS(AA00h) : Read First Checksum

AA00H	RDFCS																								
Inst/Para	R/W	Address		D15-8	D7	D6	D5	D4	D3	D2	D1	D0	HEX												
		MIPI	Other																						
RDFCS	R	AAh	AA00h	x	FCS7	FCS6	FCS5	FCS4	FCS3	FCS2	FCS1	FCS0	00												
Description	This command returns the first checksum what has been calculated from "User Command Set" area registers (not include "Manufacture Command Set) and the frame memory after the write access to those registers and/or frame memory has been done.																								
Restriction	It will be necessary to wait 150ms after there is the last write access on "User Command Set" area registers before there can read this checksum value.																								
Register Availability	<table border="1"> <thead> <tr> <th>Status</th> <th>Availability</th> </tr> </thead> <tbody> <tr> <td>Normal Mode On, Idle Mode Off, Sleep Out</td> <td>Yes</td> </tr> <tr> <td>Normal Mode On, Idle Mode On, Sleep Out</td> <td>Yes</td> </tr> <tr> <td>Partial Mode On, Idle Mode Off, Sleep Out</td> <td>Yes</td> </tr> <tr> <td>Partial Mode On, Idle Mode On, Sleep Out</td> <td>Yes</td> </tr> <tr> <td>Sleep In</td> <td>Yes</td> </tr> </tbody> </table>													Status	Availability	Normal Mode On, Idle Mode Off, Sleep Out	Yes	Normal Mode On, Idle Mode On, Sleep Out	Yes	Partial Mode On, Idle Mode Off, Sleep Out	Yes	Partial Mode On, Idle Mode On, Sleep Out	Yes	Sleep In	Yes
Status	Availability																								
Normal Mode On, Idle Mode Off, Sleep Out	Yes																								
Normal Mode On, Idle Mode On, Sleep Out	Yes																								
Partial Mode On, Idle Mode Off, Sleep Out	Yes																								
Partial Mode On, Idle Mode On, Sleep Out	Yes																								
Sleep In	Yes																								
Default	<table border="1"> <thead> <tr> <th>Status</th> <th>Default Value</th> </tr> </thead> <tbody> <tr> <td>Power On Sequence</td> <td>00h</td> </tr> <tr> <td>S/W Reset</td> <td>00h</td> </tr> <tr> <td>H/W Reset</td> <td>00h</td> </tr> </tbody> </table>													Status	Default Value	Power On Sequence	00h	S/W Reset	00h	H/W Reset	00h				
Status	Default Value																								
Power On Sequence	00h																								
S/W Reset	00h																								
H/W Reset	00h																								
Flow Chart	<pre> graph TD A[RDFCS(AAh)] --> B[/Send Parameter FCS[7:0]/] </pre> <p>Legend</p> <ul style="list-style-type: none"> Command: Rectangle Parameter: Parallelogram Display: Oval Action: Pointed Oval Mode: Rounded Rectangle Sequential transfer: Oval with tail 																								

RDCCS(AF00h) : Read Continue Checksum

AF00H		RDCCS																							
Inst/Para	R/W	Address		D15-8	D7	D6	D5	D4	D3	D2	D1	D0	HEX												
		MIPI	Other																						
RDCCS	R	AFh	AF00h	x	CCS7	CCS6	CCS5	CCS4	CCS3	CCS2	CCS1	CCS0	00												
Description	This command returns the continue checksum what has been calculated continuously after the first checksum has calculated from "User Command Set" area registers and the frame memory after the write access to those registers and/or frame memory has been done.																								
Restriction	It will be necessary to wait 300ms after there is the last write access on "User Command Set" area registers before there can read this checksum value in the first time.																								
Register Availability	<table border="1"> <thead> <tr> <th>Status</th> <th>Availability</th> </tr> </thead> <tbody> <tr> <td>Normal Mode On, Idle Mode Off, Sleep Out</td> <td>Yes</td> </tr> <tr> <td>Normal Mode On, Idle Mode On, Sleep Out</td> <td>Yes</td> </tr> <tr> <td>Partial Mode On, Idle Mode Off, Sleep Out</td> <td>Yes</td> </tr> <tr> <td>Partial Mode On, Idle Mode On, Sleep Out</td> <td>Yes</td> </tr> <tr> <td>Sleep In</td> <td>Yes</td> </tr> </tbody> </table>													Status	Availability	Normal Mode On, Idle Mode Off, Sleep Out	Yes	Normal Mode On, Idle Mode On, Sleep Out	Yes	Partial Mode On, Idle Mode Off, Sleep Out	Yes	Partial Mode On, Idle Mode On, Sleep Out	Yes	Sleep In	Yes
Status	Availability																								
Normal Mode On, Idle Mode Off, Sleep Out	Yes																								
Normal Mode On, Idle Mode On, Sleep Out	Yes																								
Partial Mode On, Idle Mode Off, Sleep Out	Yes																								
Partial Mode On, Idle Mode On, Sleep Out	Yes																								
Sleep In	Yes																								
Default	<table border="1"> <thead> <tr> <th>Status</th> <th>Default Value</th> </tr> </thead> <tbody> <tr> <td>Power On Sequence</td> <td>00h</td> </tr> <tr> <td>S/W Reset</td> <td>00h</td> </tr> <tr> <td>H/W Reset</td> <td>00h</td> </tr> </tbody> </table>													Status	Default Value	Power On Sequence	00h	S/W Reset	00h	H/W Reset	00h				
Status	Default Value																								
Power On Sequence	00h																								
S/W Reset	00h																								
H/W Reset	00h																								
Flow Chart	<pre> graph TD A[RDCCS(AFh)] --> B[/Send Parameter CCS[7:0]/] </pre> <p>Legend</p> <ul style="list-style-type: none"> Command: Rectangle Parameter: Parallelogram Display: Oval Action: Pointed Oval Mode: Rounded Rectangle Sequential transfer: Oval with tail 																								

SetDISPMode (C200h) : set_DISP Mode

C200H		SetDISPMode																							
Inst/Para	R/W	Address		D15-8	D7	D6	D5	D4	D3	D2	D1	D0	HEX												
		MIPI	Other																						
SetDISPMode	W	C2h	C200h	x	0	0	0	0	0	0	DM1	DM0	00												
Description	<table border="1"> <thead> <tr> <th>Bit</th> <th>Description</th> <th>Value</th> </tr> </thead> <tbody> <tr> <td>DM[1:0]</td> <td>Display timing mode selection</td> <td>2'b00: internal timing 2'b01: reserved 2'b10: reserved 2'b11: external timing (VSYNC + HSYNC align mode)</td> </tr> </tbody> </table>													Bit	Description	Value	DM[1:0]	Display timing mode selection	2'b00: internal timing 2'b01: reserved 2'b10: reserved 2'b11: external timing (VSYNC + HSYNC align mode)						
	Bit	Description	Value																						
DM[1:0]	Display timing mode selection	2'b00: internal timing 2'b01: reserved 2'b10: reserved 2'b11: external timing (VSYNC + HSYNC align mode)																							
Restriction	<p>Note: (1) If video mode, need to set DM[1:0] = 2'b11.</p>																								
Register Availability	<table border="1"> <thead> <tr> <th>Status</th> <th>Availability</th> </tr> </thead> <tbody> <tr> <td>Normal Mode On, Idle Mode Off, Sleep Out</td> <td>Yes</td> </tr> <tr> <td>Normal Mode On, Idle Mode On, Sleep Out</td> <td>Yes</td> </tr> <tr> <td>Partial Mode On, Idle Mode Off, Sleep Out</td> <td>Yes</td> </tr> <tr> <td>Partial Mode On, Idle Mode On, Sleep Out</td> <td>Yes</td> </tr> <tr> <td>Sleep In</td> <td>Yes</td> </tr> </tbody> </table>													Status	Availability	Normal Mode On, Idle Mode Off, Sleep Out	Yes	Normal Mode On, Idle Mode On, Sleep Out	Yes	Partial Mode On, Idle Mode Off, Sleep Out	Yes	Partial Mode On, Idle Mode On, Sleep Out	Yes	Sleep In	Yes
Status	Availability																								
Normal Mode On, Idle Mode Off, Sleep Out	Yes																								
Normal Mode On, Idle Mode On, Sleep Out	Yes																								
Partial Mode On, Idle Mode Off, Sleep Out	Yes																								
Partial Mode On, Idle Mode On, Sleep Out	Yes																								
Sleep In	Yes																								
Flow Chart	<div style="border: 1px dashed black; padding: 10px;"> <p>Legend</p> <ul style="list-style-type: none"> Command Parameter Display Action Mode Sequential transfer </div>																								

SetDSPIMode (C400h) : set_DSPI Mode

C400H		Set DSPI mode																							
Inst/Para	R/W	Address		D15-8	D7	D6	D5	D4	D3	D2	D1	D0	HEX												
		MIPI	Other																						
SetDSPIMode	W	C4h	C400h	x	SPI_WRAM	0	DSPI_CFG1	DSPI_CFG0	0	0	0	DSPI_EN	00												
Description	<table border="1"> <thead> <tr> <th>Bit</th> <th>Description</th> <th>Value</th> </tr> </thead> <tbody> <tr> <td>DSPI_EN</td> <td>DAUL SPI MODE Enable</td> <td>0: disable 1: enable</td> </tr> <tr> <td>DSPI_CFG[1:0]</td> <td>DAUL SPI MODE Selection</td> <td>00: 1P1T for 1 wire 10: 1P1T for 2 wire 11: 2P3T for 2 wire 01: reserved</td> </tr> <tr> <td>SPI_WRAM</td> <td>This command is used in SPI/SPINK interfaces. Making sure to set SPI_WRAM=1 before host writes SRAM via SPI/SPINK interfaces.</td> <td>0: disable 1: SPI interface write RAM enable</td> </tr> </tbody> </table>			Bit	Description	Value	DSPI_EN	DAUL SPI MODE Enable	0: disable 1: enable	DSPI_CFG[1:0]	DAUL SPI MODE Selection	00: 1P1T for 1 wire 10: 1P1T for 2 wire 11: 2P3T for 2 wire 01: reserved	SPI_WRAM	This command is used in SPI/SPINK interfaces. Making sure to set SPI_WRAM=1 before host writes SRAM via SPI/SPINK interfaces.	0: disable 1: SPI interface write RAM enable										
	Bit	Description	Value																						
	DSPI_EN	DAUL SPI MODE Enable	0: disable 1: enable																						
	DSPI_CFG[1:0]	DAUL SPI MODE Selection	00: 1P1T for 1 wire 10: 1P1T for 2 wire 11: 2P3T for 2 wire 01: reserved																						
SPI_WRAM	This command is used in SPI/SPINK interfaces. Making sure to set SPI_WRAM=1 before host writes SRAM via SPI/SPINK interfaces.	0: disable 1: SPI interface write RAM enable																							
Note: detailed DAUL SPI formats are described at next page.																									
Restriction																									
Register Availability	<table border="1"> <thead> <tr> <th>Status</th> <th>Availability</th> </tr> </thead> <tbody> <tr> <td>Normal Mode On, Idle Mode Off, Sleep Out</td> <td>Yes</td> </tr> <tr> <td>Normal Mode On, Idle Mode On, Sleep Out</td> <td>Yes</td> </tr> <tr> <td>Partial Mode On, Idle Mode Off, Sleep Out</td> <td>Yes</td> </tr> <tr> <td>Partial Mode On, Idle Mode On, Sleep Out</td> <td>Yes</td> </tr> <tr> <td>Sleep In</td> <td>Yes</td> </tr> </tbody> </table>													Status	Availability	Normal Mode On, Idle Mode Off, Sleep Out	Yes	Normal Mode On, Idle Mode On, Sleep Out	Yes	Partial Mode On, Idle Mode Off, Sleep Out	Yes	Partial Mode On, Idle Mode On, Sleep Out	Yes	Sleep In	Yes
	Status	Availability																							
	Normal Mode On, Idle Mode Off, Sleep Out	Yes																							
	Normal Mode On, Idle Mode On, Sleep Out	Yes																							
	Partial Mode On, Idle Mode Off, Sleep Out	Yes																							
	Partial Mode On, Idle Mode On, Sleep Out	Yes																							
Sleep In	Yes																								
Flow Chart	<div style="border: 1px dashed black; padding: 5px;"> <p>Legend</p> <ul style="list-style-type: none"> Command Parameter Display Action Mode Sequential transfer </div>																								

DUAL SPI via SPI3 interface :

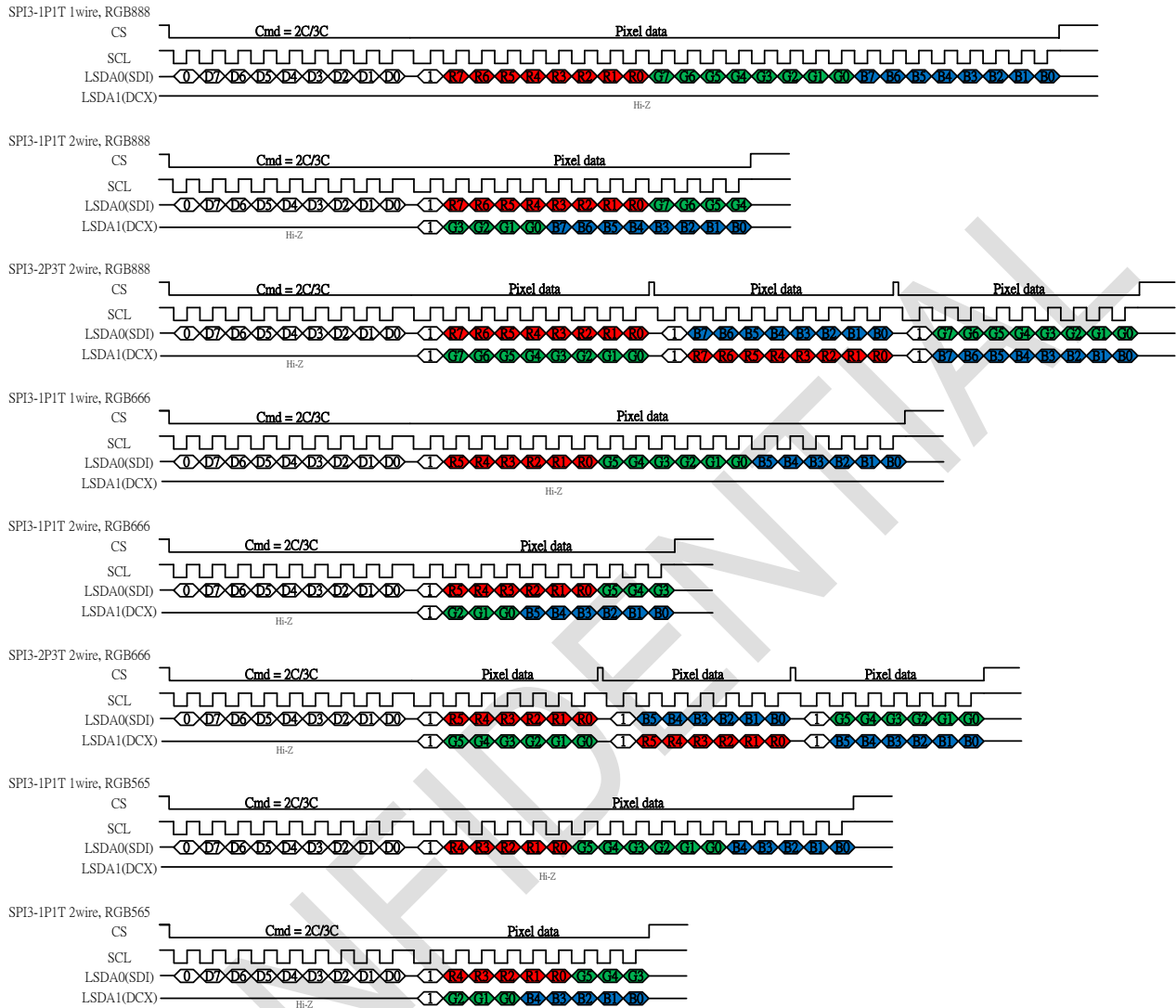

DUAL SPI via SPI4 interface :

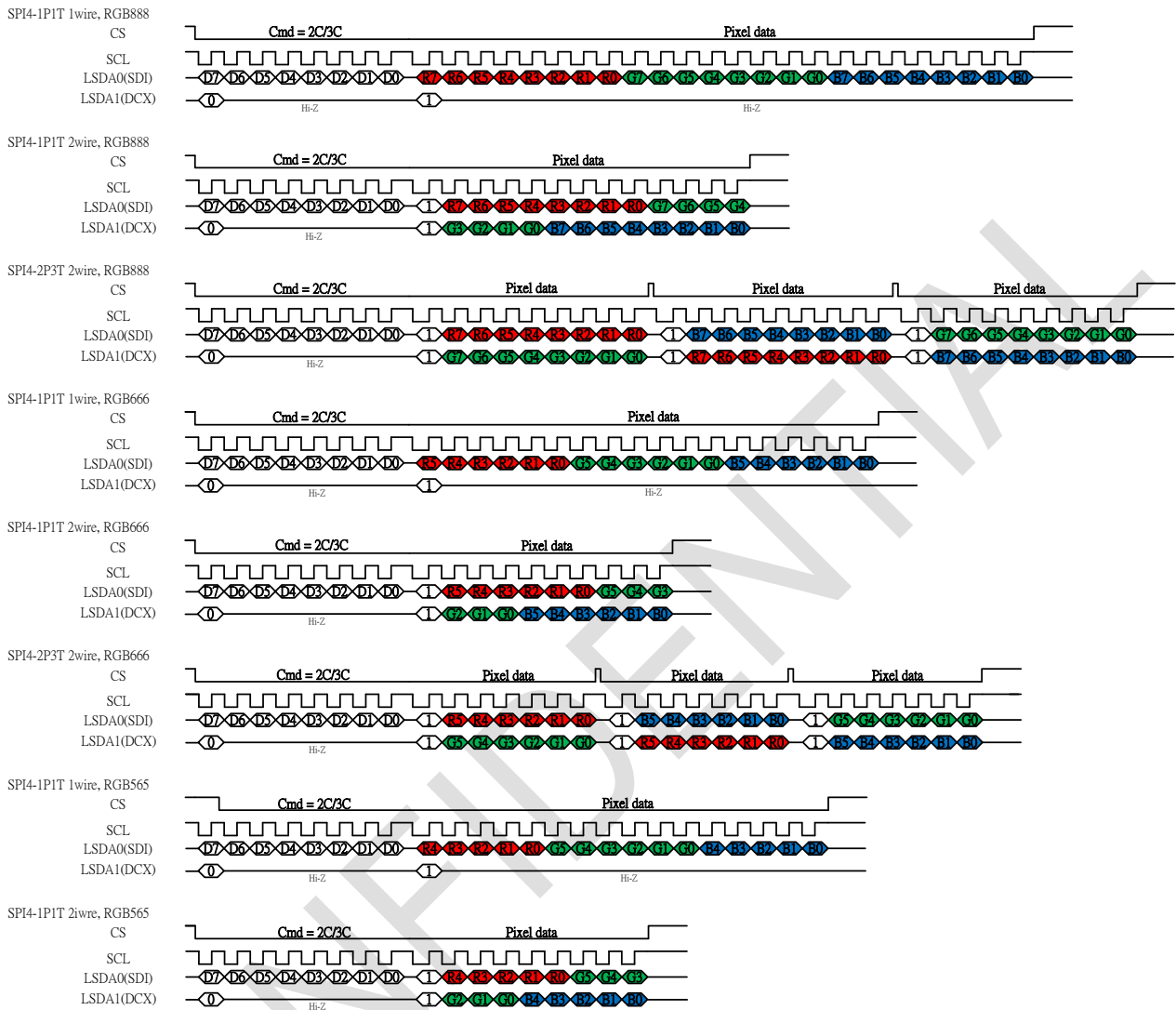

RDID1 (DA00h): ID1 Code

0XDA00h		WRDID																					
Instruction	R/W	Address			Parameter																		
		MIPI	Others	D15-D8	D7	D6	D5	D4	D3	D2	D1	D0	HEX										
WRDID	R	0xDAh	0XDA00h	00h	ID1[7:0]							0x00h											
Description	This command is for Module Manufacture Number																						
	<table border="1"> <thead> <tr> <th>Bit</th> <th>Description</th> <th>Data</th> </tr> </thead> <tbody> <tr> <td>ID1[7:0]</td> <td>Module Manufactor Number</td> <td></td> </tr> </tbody> </table>		Bit	Description	Data	ID1[7:0]	Module Manufactor Number																
Bit	Description	Data																					
ID1[7:0]	Module Manufactor Number																						
Restriction																							
Register Availability	<table border="1"> <thead> <tr> <th>Status</th> <th>Availability</th> </tr> </thead> <tbody> <tr> <td>Normal Mode On, Idle Mode Off, Sleep Out</td> <td>Yes</td> </tr> <tr> <td>Normal Mode On, Idle Mode On, Sleep Out</td> <td>Yes</td> </tr> <tr> <td>Partial Mode On, Idle Mode Off, Sleep Out</td> <td>Yes</td> </tr> <tr> <td>Partial Mode On, Idle Mode On, Sleep Out</td> <td>Yes</td> </tr> <tr> <td>Sleep In</td> <td>Yes</td> </tr> </tbody> </table>		Status	Availability	Normal Mode On, Idle Mode Off, Sleep Out	Yes	Normal Mode On, Idle Mode On, Sleep Out	Yes	Partial Mode On, Idle Mode Off, Sleep Out	Yes	Partial Mode On, Idle Mode On, Sleep Out	Yes	Sleep In	Yes									
	Status	Availability																					
	Normal Mode On, Idle Mode Off, Sleep Out	Yes																					
	Normal Mode On, Idle Mode On, Sleep Out	Yes																					
	Partial Mode On, Idle Mode Off, Sleep Out	Yes																					
	Partial Mode On, Idle Mode On, Sleep Out	Yes																					
Sleep In	Yes																						
Default	<table border="1"> <thead> <tr> <th rowspan="2">Status</th> <th>Default Value</th> </tr> <tr> <th>0xDAh / 0XDA00h</th> </tr> </thead> <tbody> <tr> <td>Power On Sequence</td> <td>0x00h</td> </tr> <tr> <td>S/W Reset</td> <td>0x00h</td> </tr> <tr> <td>H/W Reset</td> <td>0x00h</td> </tr> </tbody> </table>		Status	Default Value	0xDAh / 0XDA00h	Power On Sequence	0x00h	S/W Reset	0x00h	H/W Reset	0x00h												
	Status	Default Value																					
		0xDAh / 0XDA00h																					
	Power On Sequence	0x00h																					
	S/W Reset	0x00h																					
H/W Reset	0x00h																						

RDID2 (DB00h): ID2 Code





0XDB00h		WRDID														
Instruction	R/W	Address			Parameter								HEX			
		MIPI	Others	D15-D8	D7	D6	D5	D4	D3	D2	D1	D0				
WRDID	R	0xDBh	0XDB00h	00h	ID2[7:0]							0x80h				
Description	This command is for Module/Driver Version Number															
			<table border="1"> <thead> <tr> <th>Bit</th> <th>Description</th> <th>Data</th> </tr> </thead> <tbody> <tr> <td>ID2[7:0]</td> <td>Module/Driver Version Number</td> <td></td> </tr> </tbody> </table>		Bit	Description	Data	ID2[7:0]	Module/Driver Version Number							
Bit	Description	Data														
ID2[7:0]	Module/Driver Version Number															
Restriction																
Register Availability			<table border="1"> <thead> <tr> <th>Status</th> <th>Availability</th> </tr> </thead> <tbody> <tr> <td>Normal Mode On, Idle Mode Off, Sleep Out</td> <td>Yes</td> </tr> <tr> <td>Normal Mode On, Idle Mode On, Sleep Out</td> <td>Yes</td> </tr> <tr> <td>Partial Mode On, Idle Mode Off, Sleep Out</td> <td>Yes</td> </tr> <tr> <td>Partial Mode On, Idle Mode On, Sleep Out</td> <td>Yes</td> </tr> <tr> <td>Sleep In</td> <td>Yes</td> </tr> </tbody> </table>		Status	Availability	Normal Mode On, Idle Mode Off, Sleep Out	Yes	Normal Mode On, Idle Mode On, Sleep Out	Yes	Partial Mode On, Idle Mode Off, Sleep Out	Yes	Partial Mode On, Idle Mode On, Sleep Out	Yes	Sleep In	Yes
	Status	Availability														
	Normal Mode On, Idle Mode Off, Sleep Out	Yes														
	Normal Mode On, Idle Mode On, Sleep Out	Yes														
	Partial Mode On, Idle Mode Off, Sleep Out	Yes														
	Partial Mode On, Idle Mode On, Sleep Out	Yes														
Sleep In	Yes															
Default			<table border="1"> <thead> <tr> <th>Status</th> <th>Default Value</th> </tr> </thead> <tbody> <tr> <td></td> <td>0xDBh / 0XDB00h</td> </tr> <tr> <td>Power On Sequence</td> <td>0x80h</td> </tr> <tr> <td>SW Reset</td> <td>0x80h</td> </tr> <tr> <td>HW Reset</td> <td>0x80h</td> </tr> </tbody> </table>		Status	Default Value		0xDBh / 0XDB00h	Power On Sequence	0x80h	SW Reset	0x80h	HW Reset	0x80h		
	Status	Default Value														
		0xDBh / 0XDB00h														
	Power On Sequence	0x80h														
	SW Reset	0x80h														
HW Reset	0x80h															

RDID3 (DC00h): ID3 Code

0xDC00h		WRDID											
Instruction	R/W	Address			Parameter								
		MIPI	Others	D15-D8	D7	D6	D5	D4	D3	D2	D1	D0	HEX
WRDID	R	0xDCCh	0xDC00h	00h	ID3[7:0]							0x00h	
Description	This command is for Module / Driver ID												
			Bit	Description	Data								
		ID3[7:0]		Module /Driver ID									
Restriction													
Register Availability				Status				Availability					
				Normal Mode On, Idle Mode Off, Sleep Out				Yes					
				Normal Mode On, Idle Mode On, Sleep Out				Yes					
				Partial Mode On, Idle Mode Off, Sleep Out				Yes					
				Partial Mode On, Idle Mode On, Sleep Out				Yes					
				Sleep In				Yes					
Default				Status		Default Value							
						0xDCCh / 0xDC00h							
				Power On Sequence		0x00h							
				S/W Reset		0x00h							
				H/W Reset		0x00h							

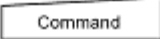
(FE00h): CMD Mode Switch

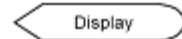
FE00H	MAUCCTR (Manufacture Command Set Control)												
Instruction	R/W	Address		Parameter									
		MIPI	Others	D15-D8	D7	D6	D5	D4	D3	D2	D1	D0	HEX
CMD Mode Switch	W	FEh	FE00h	00h	-	-	-	-	CMD_Page[3:0]			00	
Description	This command is used to switch the Manufacture Command Pages and User Commands sets.												
	CMD_Page[3:0]		Hex Value		Description								
	0000		00h (default)		User Command Set (UCS = CMD1)								
	0001		01h		Manufacture Command Set Page0								
	1100		0Ch		Manufacture Command Set Page0 extension								
	1011		0Bh		Manufacture Command Set Page Panel ID								
	0010		02h		Manufacture Command Set Page Gamma1								
	0011		03h		Manufacture Command Set Page Gamma2								
	1101		0Dh		Manufacture Command Set Page Gamma3								
	0100		04h		Manufacture Command Set Page VSR								
0110		06h		Manufacture Command Set Page DBC									
Restriction	-												
Register Availability	Status				Availability								
	Normal Mode On, Idle Mode Off, Sleep Out				Yes								
	Normal Mode On, Idle Mode On, Sleep Out				Yes								
	Partial Mode On, Idle Mode Off, Sleep Out				Yes								
	Partial Mode On, Idle Mode On, Sleep Out				Yes								
	Sleep In				Yes								

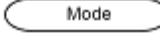
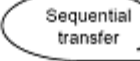
Default	Status	Default Value
		FEh / FE00h
	Power On Sequence	00h
	S/W Reset	00h
	H/W Reset	00h
Flow Chart	<div style="border: 1px dashed black; padding: 10px;"> <p>Legend</p> <ul style="list-style-type: none"> Command  Parameter  Display  Action  Mode  Sequential transfer  </div>	

CONFIDENTIAL

(FF00h): Read CMD Status

FF00H	MAUCCTR (Manufacture Command Set Control)												
Instruction	R/W	Address		Parameter									
		MIPI	Others	D15-D8	D7	D6	D5	D4	D3	D2	D1	D0	HEX
RD CMD Status	R	FFh	FF00h	00h	-	-	-	-	CMD_Status[3:0]			00	
Description	This command is used to switch the Manufacture Command Pages and User Commands sets.												
	CMD_Status[3:0]		Hex Value		Description								
	0000		00h (default)		User Command Set (UCS = CMD1)								
	0001		01h		Manufacture Command Set Page0								
	1100		0Ch		Manufacture Command Set Page0 extension								
	1011		0Bh		Manufacture Command Set Page Panel ID								
	0010		02h		Manufacture Command Set Page Gamma1								
	0011		03h		Manufacture Command Set Page Gamma2								
	1101		0Dh		Manufacture Command Set Page Gamma3								
	0100		04h		Manufacture Command Set Page VSR								
	0110		06h		Manufacture Command Set Page DBC								
Restriction	-												
Register Availability	Status				Availability								
	Normal Mode On, Idle Mode Off, Sleep Out				Yes								
	Normal Mode On, Idle Mode On, Sleep Out				Yes								
	Partial Mode On, Idle Mode Off, Sleep Out				Yes								
	Partial Mode On, Idle Mode On, Sleep Out				Yes								
Sleep In				Yes									

Default	Status	Default Value
		FFh / FF00h
	Power On Sequence	00h
	S/W Reset	00h
	H/W Reset	00h

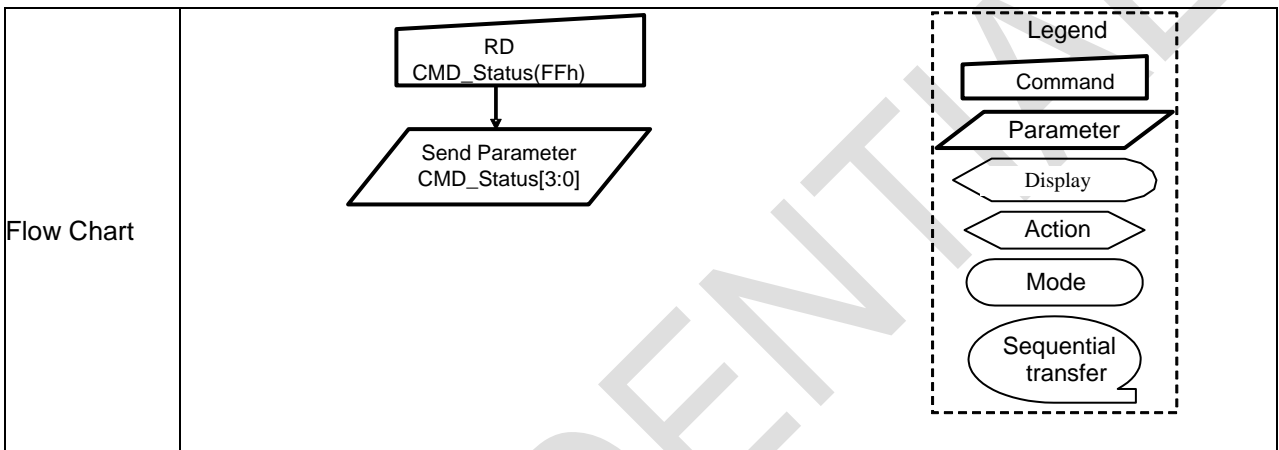

7. Electrical Characteristics

7.1 Absolute Maximum Ratings

The absolute maximum rating is listed on following table. When RM69330 is used out of the absolute maximum ratings, the RM69330 may be permanently damaged. To use the RM69330 within the following electrical characteristics limit is strongly recommended for normal operation. If these electrical characteristic conditions are exceeded during normal operation, the RM69330 will malfunction and cause poor reliability.

item	Symbol	Value	Unit
Power supply voltage	VDDI	-0.3 ~ + 5.5	V
Power supply voltage	VDD (VDDA, VDDDB, VDDR)	-0.3 ~ + 5.5	V
Supply voltage (MV)	AVDD- AVSS	-0.3 ~ + 6.6	V
	AVSS- VCL	-0.3 ~ + 5.0	V
Supply voltage (HV)	VGH- VGLX	-0.3 ~ + 33	V
Input voltage	VIN	-0.3 ~ VDDI+ 0.3	V
Output voltage	VO	-0.3 ~ VDDI+ 0.3	V
Operating temperature	Topr	-40 ~ + 85	°C
Storage temperature	Tstg	-55 ~ + 125	°C
Notes: If one of the above items is exceeded its maximum limitation momentarily, the quality of the product may be degraded. Absolute maximum limitation. Therefore, specify the values exceeding which the product may be physically damaged. Be sure to use the product within the recommend range.			

7.2 ESD Protection Level

Model	Test Condition	Level
Human Body Mode	R = 1.5 kohm / C = 100 pF	Pass 3KV
Machine Mode	R = 0 ohm / C = 200 pF	Pass 300V

7.3 Latch-Up Protection Level

The device will not latch up at trigger current levels less than ± 200 mA.

7.4 DC Characteristics

7.4.1 Basic Characteristics

Parameter	Symbol	Condition	Min.	Typ.	Max.	Unit	Related Pins
Analog Power Supply Voltage	VDD	Operation Voltage	2.7	2.8	3.6	V	Note 1
I/O pin Power Supply Voltage	VDDI	I/O supply voltage	1.65	1.8	3.3	V	Note 1,2
Logic High level input voltage	VIH	VDDI = 1.65V ~ 3.3V	0.8* VDDI	-	VDDI	V	Note 3
Logic Low level input voltage	VIL	VDDI = 1.65V ~ 3.3V	0.0	-	0.2* VDDI	V	Note 3
Logic High level Output voltage	VOH	Iout = -1 mA	0.8* VDDI	-	VDDI	V	Note 3
Logic Low level Output voltage	VOL	Iout = +1 mA	0.0	-	0.2* VDDI	V	Note 3
Logic High level input current (Except MIPI)	IIHD	Vin=0~VDDI			1	uA	Note 3
Logic Low level input current (Except MIPI)	IILD	Vin=0~VDDI	-1			uA	Note 3
Logic High level input current (MIPI)	IIHD	Vin=0~VDDI			1	uA	Note 3
Logic Low level input current (MIPI)	IILD	Vin=0~VDDI	-1			uA	Note 3
AVDD booster voltage	AVDD		4.5		6.5	V	Note 3
VCL booster voltage	VCL		-3.5		-5	V	Note 3
VGH booster voltage	VGH		AVDD		2AVDD	V	Note 3
VGL booster voltage	VGL		VCL		VCL -AVDD	V	Note 3
Voltage difference between VGH and VGL	VGHL	VGH-VGL			30	V	Note 3
Gamma reference voltage	VGMP		2.0		6.0	V	Note 3,4
Gamma reference voltage	VGSP		0.0		4.5	V	Note 3
OSC	Fosc		20.24	22	23.76	MHz	
Channel deviation voltage	V _{DEV}	Sout ≥ AVDD-1.0V, and 0V < Sout ≤ 1.0V				mV	TBD
Channel deviation voltage	V _{DEV}	1.0V < Sout < AVDD-1.0V				mV	TBD

Notes:

1. VDD means VDDA, VDDR, Vddb. And VSS means VSSA, VSSR, VSSB, AVSS, VSSAM. Vddb, VDDA and VDDR should be the same input voltage level and larger than VDDI voltage.
2. Recommend VDDI=1.8V for power saving.
3. Ta(ambient temperature) ranges from -30°C to 85 °C.
4. VGMP ≤ AVDD – 0.5V

7.4.2 Operation current

VCI=2.8V and VDDI=1.8V

Parameter	Symbol	Condition	Max.	Unit
Sleep In Mode	I_SLP_VCI	VDDI=VCC=1.8V VCI=VDDA=VDDB=VDDR=2.8V	50	uA
	I_SLP_VDDI	HSSI_D0P/N=HSSI_D1P/N=HSSI_CKP/N=LP-11 Ta = 25deg	180	uA
Deep Standby Mode	I_DSTB_VCI	VDDI=VCC=1.8V VCI=VDDA=VDDB=VDDR=2.8V	4	uA
	I_DSTB_VDDI	HSSI_D0P/N=HSSI_D1P/N=HSSI_CKP/N=0 Ta = 25deg	1	uA

CONFIDENTIAL

7.5 MIPI Characteristics

7.5.1 High-Speed Receiver Specification

DC Specifications

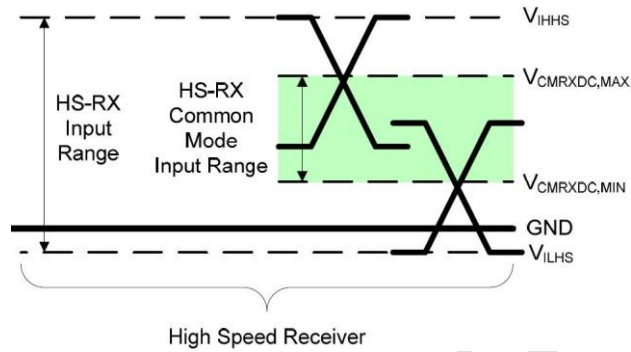

Parameter	Description	Min	Nom	Max	Units	Note
VCMRX(DC)	Common-mode voltage HS receive mode	70		330	mV	1,2
WIDTH	Differential input high threshold			70	mV	
VIDTL	Differential input low threshold	-70			mV	
VIHHS	Single-ended input high voltage			460	mV	1
VILHS	Single-ended input low voltage	-40			mV	1
ZID	Differential input impedance	80	100	125	Ω	

Notes:

1. Excluding possible additional RF interference of 100mV peak sine wave beyond 450MHz.
2. This table value includes a ground difference of 50mV between the transmitter and the receiver, the static common-mode level tolerance and variations below 450MHz

7.5.2 Forward high speed transmissions

DDR Clock Definition

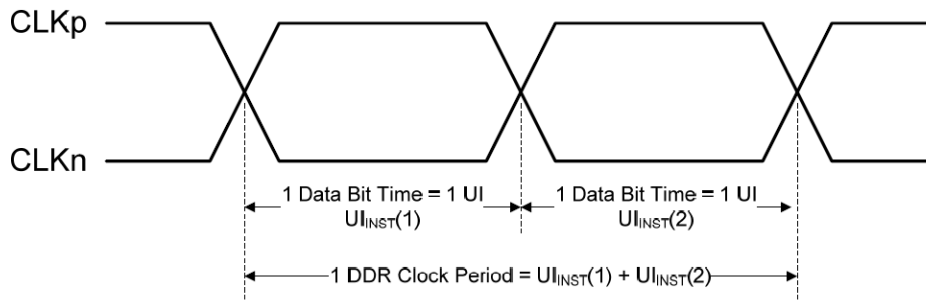

Clock Parameter	Symbol	Min	Typ	Max	Units	Notes
UI instantaneous	UI_{INST}	2		12.5	ns	1,2

Notes:

1. This value corresponds to a minimum 80 Mbps data rate.
2. The minimum UI shall not be violated for any single bit period, i.e., any DDR half cycle within a data burst.

Data-Clock Timing Specifications

Parameter	Symbol	Min	Typ	Max	Units	Notes
Data to Clock Skew [measured at transmitter]	$T_{SKEW[TX]}$	-0.15		0.15	UI_{INST}	1
Data to Clock Setup Time [receiver]	$T_{SETUP[RX]}$	0.15			UI_{INST}	2
Clock to Data Hold Time [receiver]	$T_{HOLD[RX]}$	0.15			UI_{INST}	2

Notes:

1. Total silicon and package delay budget of $0.3 \cdot UI_{INST}$
2. Total setup and hold window for receiver of $0.3 \cdot UI_{INST}$

7.5.3 Data to Clock Timing Definitions

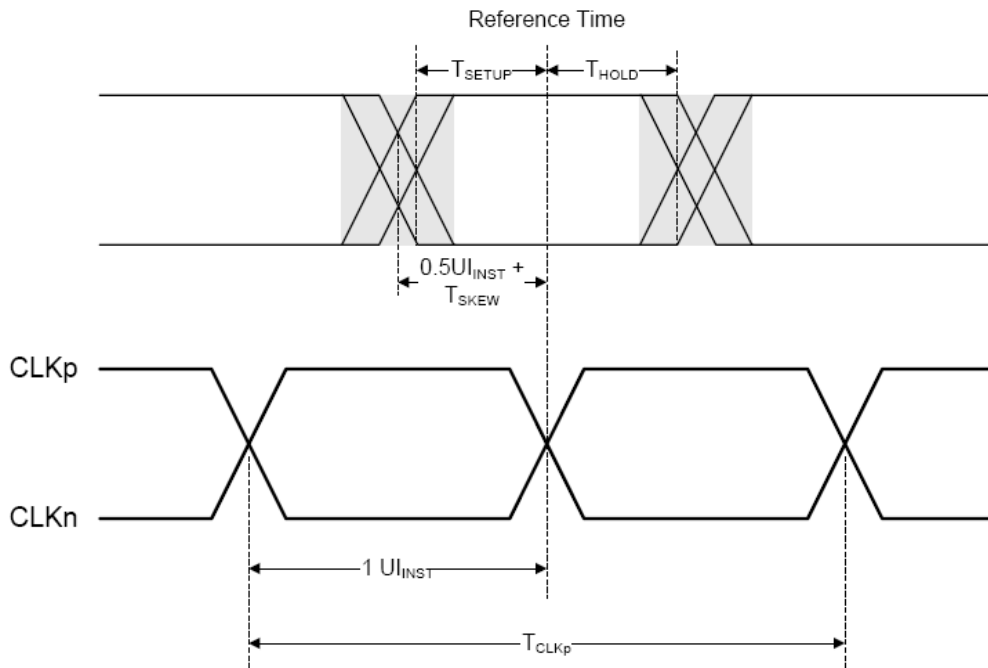

CONFIDENTIAL

7.5.4 Low power transceiver specifications

Parameters	Symbol	Condition	Min	Typ	Max	Unit
Logic high level input voltage	VIHCD	Contention Detection (Lane_D0)	450		1350	mV
Logic low level input voltage	VILCD	Contention Detection (Lane_D0)	0		200	mV
Logic high level input voltage	VIH-LPRX	LP-Rx (Lane_CK, Lane_D0, Lane_D1)	880	-	1350	mV
Logic low level input voltage	VIL-LPRX	LP-Rx (Lane_CK, Lane_D0, Lane_D1)	0		550	mV
Logic low level input voltage	VIL-ULPS	LP-Rx ULPS (Lane_CK, Lane_D0, Lane_D1)	0		300	mV
Logic high level input voltage	VOH-LPTX	Contention Detection (Lane_D0)	1.1	1.2	1.3	V
Logic low level input voltage	VOL-LPTX	Contention Detection (Lane_D0)	-50	0	50	mV
eSPIKE ^(1,2,3)	Fig. 2	Input pulse rejection			300	V.ps

Notes:

Time-voltage integration of a spike above VIL when being in LP-0 state or below VIH when being in LP-1 State.

An impulse less than this will not change the receiver state.

In addition to the required glitch rejection, implementers shall ensure rejection of known RF-interferers.

Input Glitch Rejection of Low Power Receivers as follow.

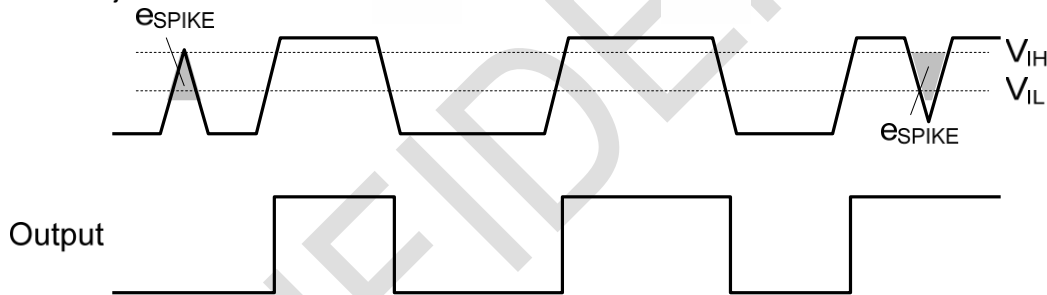

7.6 AC Characteristics

7.6.1 Serial Interface Characteristics

3-Wire SPI Serial Interface Characteristics

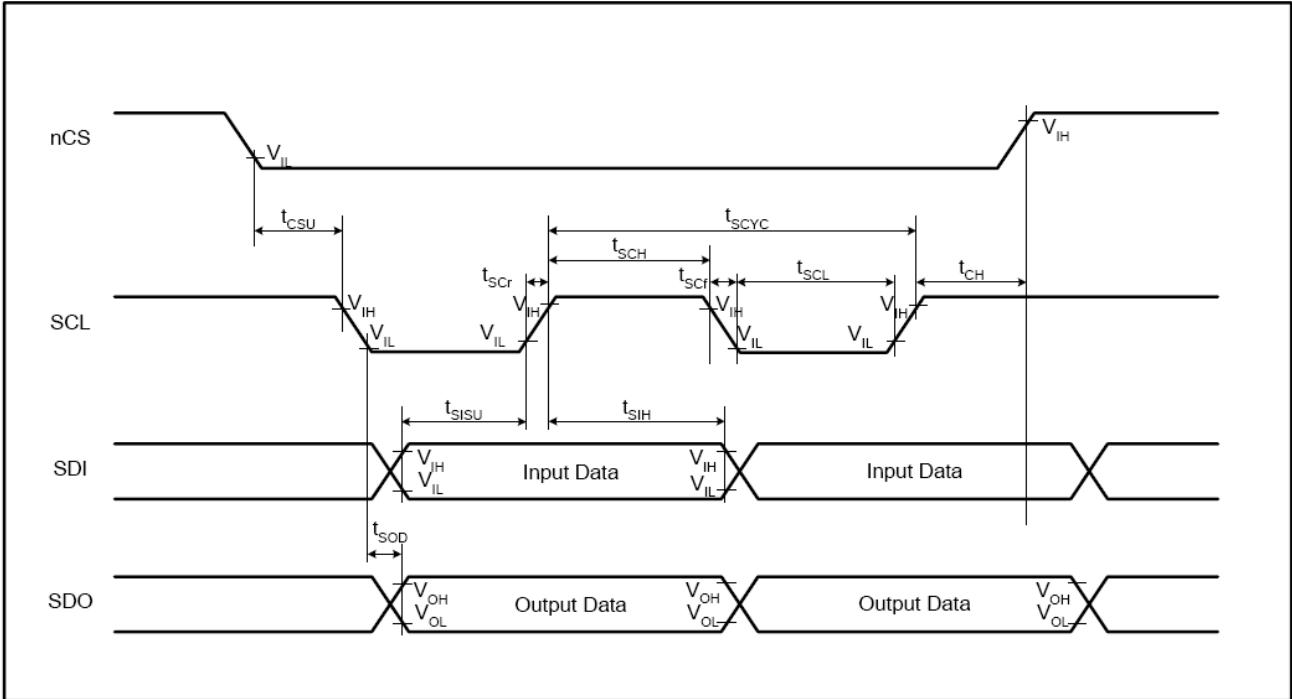

4-Wire SPI Serial Interface Characteristics

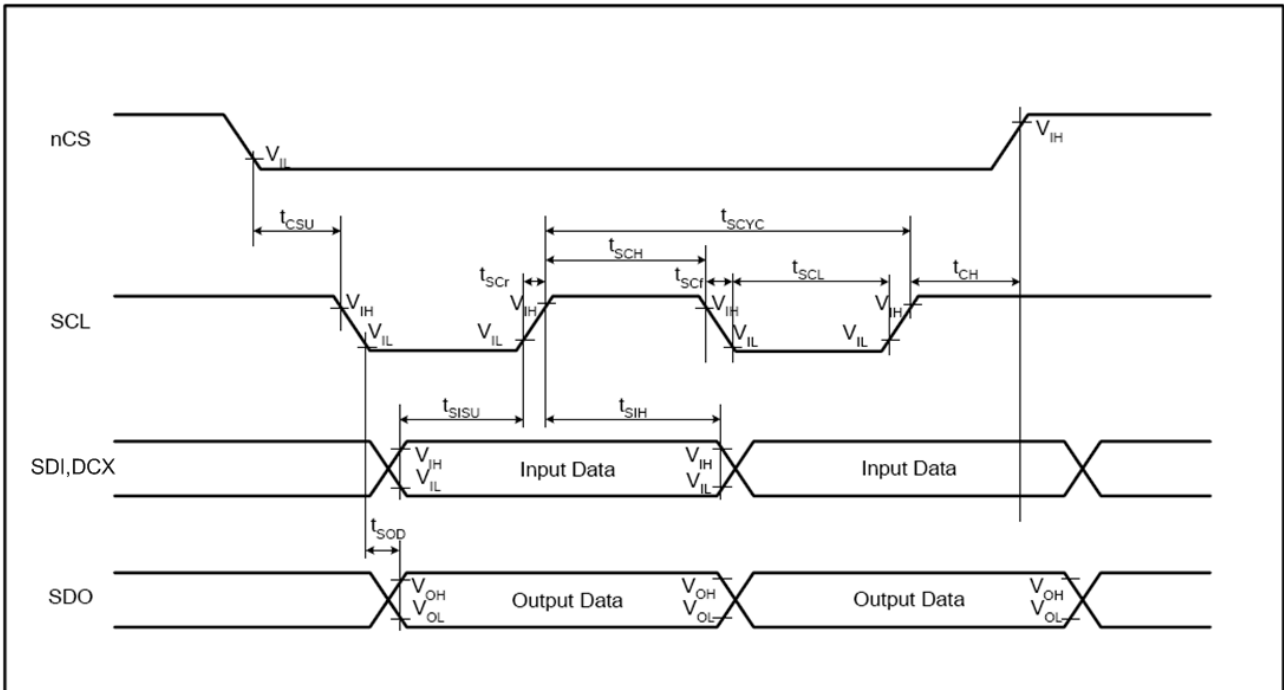

Signal	Symbol	Parameter	MIN	MAX	Unit	Description
SCL	T _{SCYC}	Clock cycle (Write)	20		ns	
	T _{SCYC}	Clock cycle (Read)	300		ns	
	T _{SCH}	Clock "H" pulse width (Write)	9		ns	
	T _{SCH}	Clock "H" pulse width (Read)	140		ns	
	T _{SCL}	Clock "L" pulse width (Write)	9		ns	
	T _{SCL}	Clock "L" pulse width (Read)	140		ns	
	T _{SCr}	Clock rise time		2	ns	
	T _{SCf}	Clock fall time		2	ns	
nCS	T _{CSU}	Chip select setup time	10		ns	
	T _{CH}	Chip select hold time	10		ns	
SDI (SDA)	T _{SISU}	Data input setup time	5		ns	
	T _{SIH}	Data input hold time	5		ns	
SDO (SDA)	T _{SOD}	Data output setup time		120	ns	
	T _{SOH}	Data output hold time	5		ns	

Note: Logic high and low levels are specified as 20% and 80% of VDDI for Input signals.

Note: Ta = -30 to 70 °C, VDDI=1.65V to 3.3V, VDD=2.7V to 3.6V, GND=0V

CONFIDENTIAL

7.6.2 DSI Timing Characteristics

HS Data Transmission Burst

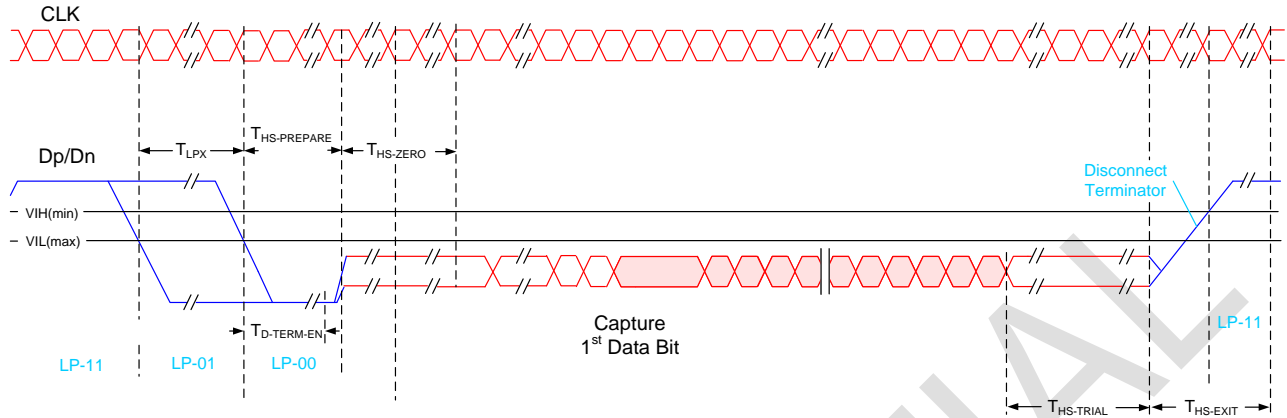

HS clock transmission

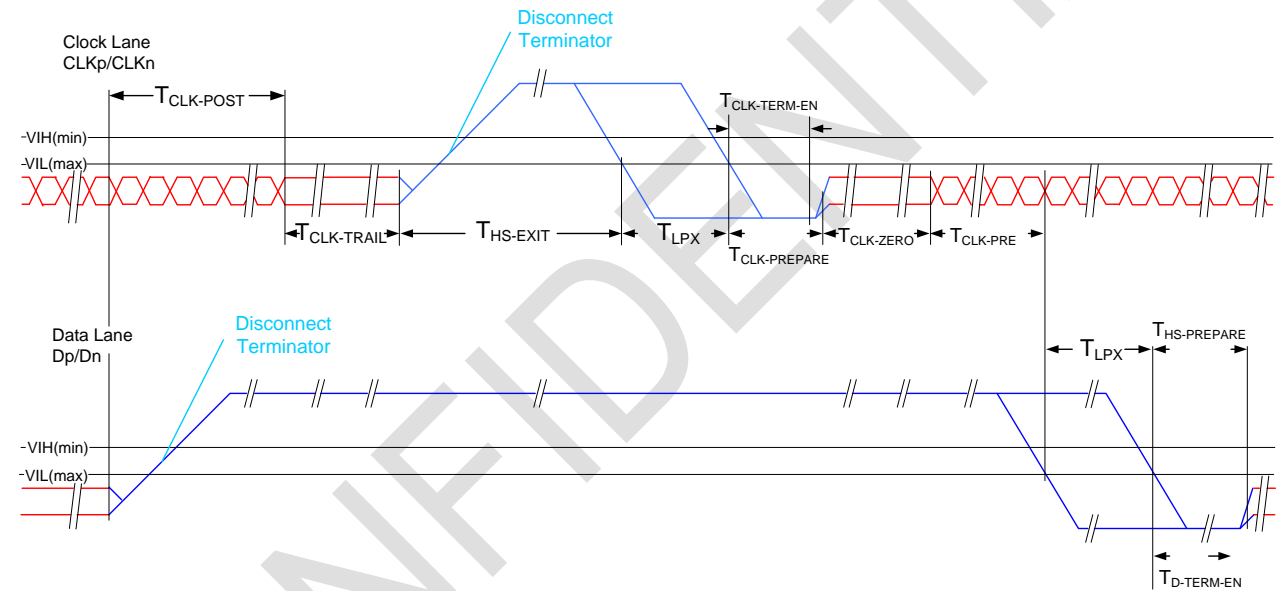

Timing Parameters:

Parameter	Description	Min	Typ	Max	Unit
$T_{CLK-POST}$	Time that the transmitter continues to send HS clock after the last associated Data Lane has transitioned to LP Mode. Interval is defined as the period from the end of $T_{HS-TRAIL}$ to the beginning of $T_{CLK-TRAIL}$.	$60ns + 52*UI$			ns
$T_{CLK-TRAIL}$	Time that the transmitter drives the HS-0 state after the last payload clock bit of a HS transmission burst.	60			ns
$T_{HS-EXIT}$	Time that the transmitter drives LP-11 following a HS burst.	300			ns
$T_{CLK-TERM-EN}$	Time for the Clock Lane receiver to enable the HS line termination, starting from the time point when Dn crosses $V_{IL,MAX}$.	Time for Dn to reach $V_{TERM-EN}$		38	ns
$T_{CLK-PREPARE}$	Time that the transmitter drives the Clock Lane LP-00 Line state immediately before the HS-0 Line state starting the HS transmission.	38		95	ns
$T_{CLK-PRE}$	Time that the HS clock shall be driven by the transmitter prior to any associated Data Lane beginning the transition from LP to HS mode.	8			UI
$T_{CLK-PREPARE} + T_{CLK-ZERO}$	$T_{CLK-PREPARE}$ + time that the transmitter drives the HS-0 state prior to starting the Clock.	300			ns
$T_{D-TERM-EN}$	Time for the Data Lane receiver to enable the HS line termination, starting from the time point when Dn crosses $V_{IL,MAX}$.	Time for Dn to reach $V_{TERM-EN}$		$35 ns + 4*UI$	
$T_{HS-PREPARE}$	Time that the transmitter drives the Data Lane LP-00 Line state immediately before the HS-0 Line state starting the HS transmission	$40ns + 4*UI$		$85 ns + 6*UI$	ns
$T_{HS-PREPARE} + T_{HS-ZERO}$	$T_{HS-PREPARE}$ + time that the transmitter drives the HS-0 state prior to transmitting the Sync sequence.	$145ns + 10*UI$			ns
$T_{HS-TRAIL}$	Time that the transmitter drives the flipped differential state after last payload data bit of a HS transmission burst	$60ns + 4*UI$			ns

Turnaround Procedure

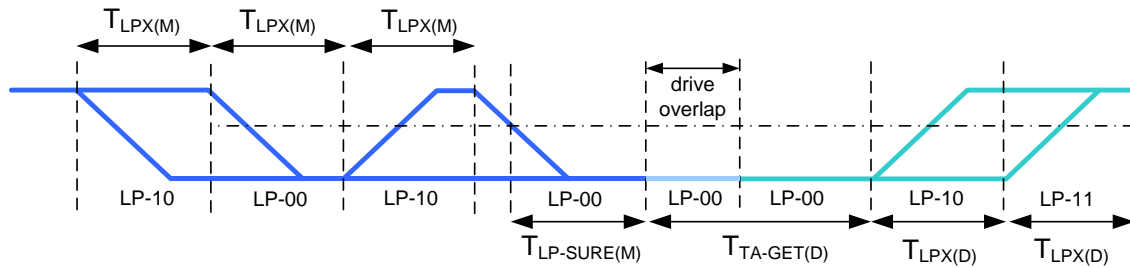

Bus turnaround (BAT) from MPU to display module timing

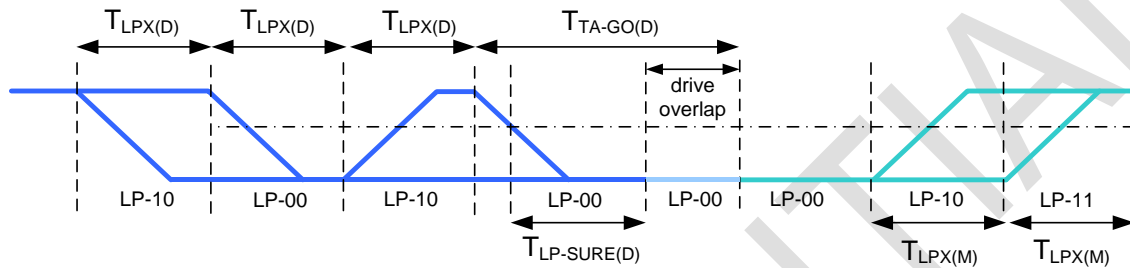

Bus turnaround (BAT) from display module to MPU timing

Low Power Mode :

Parameter	Description	Min	Typ	Max	Unit	Notes
$T_{LPX(M)}$	Transmitted length of any Low-Power state period of MCU to display module	50		150	ns	1,2
$T_{TA-SURE(M)}$	Time that the display module waits after the LP-10 state before transmitting the Bridge state (LP-00) during a Link Turnaround.	$T_{LPX(M)}$		$2 * T_{LPX(M)}$	ns	2
$T_{LPX(D)}$	Transmitted length of any Low-Power state period of display module to MCU	50		150	ns	1,2
$T_{TA-GET(D)}$	Time that the display module drives the Bridge state (LP-00) after accepting control during a Link Turnaround.		$5 * T_{LPX(D)}$		ns	2
$T_{TA-GO(D)}$	Time that the display module drives the Bridge state (LP-00) before releasing control during a Link Turnaround.		$4 * T_{LPX(D)}$		ns	2
$T_{TA-SURE(D)}$	Time that the MPU waits after the LP-10 state before transmitting the Bridge state (LP-00) during a Link Turnaround.	$T_{LPX(D)}$		$2 * T_{LPX(D)}$	ns	2

NOTE:

- T_{LPX} is an internal state machine timing reference. Externally measured values may differ slightly from the specified values due to asymmetrical rise and fall times.
- Transmitter-specific parameter

7.6.3 Reset Timing

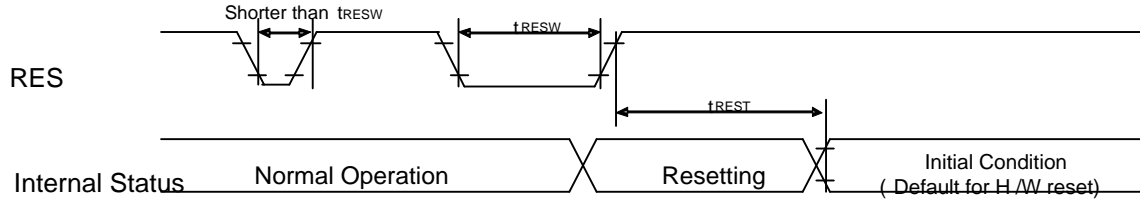

Reset input timing:

VDDI=1.65 to 3.3V, VDD=2.7 to 3.6V, AGND=DGND=0V, Ta=-40 to 85°C

Symbol	Parameter	Related Pins	MIN	TYP	MAX	Note	Unit
t_{RESW}	*1) Reset low pulse width	RESX	10	-	-	-	μ S
t_{REST}	*2) Reset complete time	-	-	-	5	When reset applied during Sleep in mode	ms
		-	-	-	120	When reset applied during Sleep out mode	ms

Note 1) Spike due to an electrostatic discharge on RESX line does not cause irregular system reset according to the table below.

RESX Pulse	Action
Shorter than 5 μ s	Reset Rejected
Longer than 10 μ s	Reset
Between 5 μ s and 10 μ s	Reset starts (It depends on voltage and temperature condition.)

Note 2. During the resetting period, the display will be blanked (The display is entering blanking sequence, which maximum time is 120 ms, when Reset Starts in Sleep Out –mode). The display remains the blank state in Sleep In –mode) and then return to Default condition for H/W reset.

Note 3. During Reset Complete Time, data in OTP will be latched to internal register during this period. This loading is done every time when there is H/W reset complete time (t_{REST}) within 5ms after a rising edge of RESX.

Note 4. Spike Rejection also applies during a valid reset pulse as shown below:

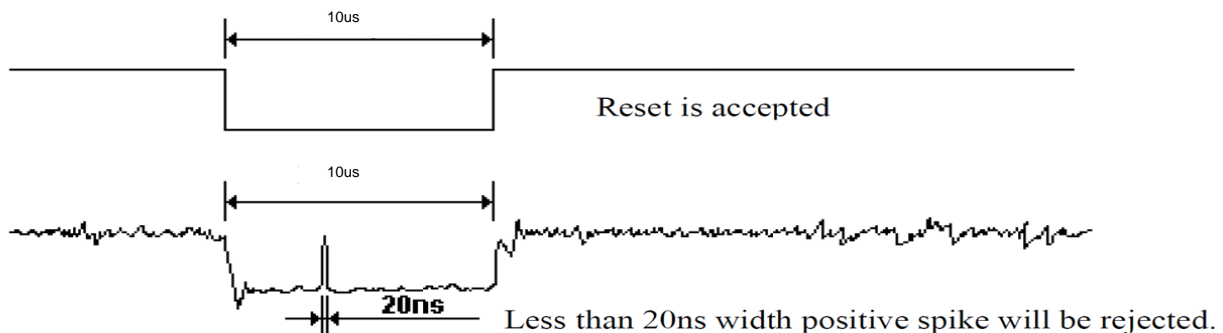

Note 5. It is necessary to wait 5msec after releasing RESX before sending commands. Also Sleep Out command cannot be sent for 120msec.

8. Power Generation

8.1 2 Supply Power (VDDI / VDD)

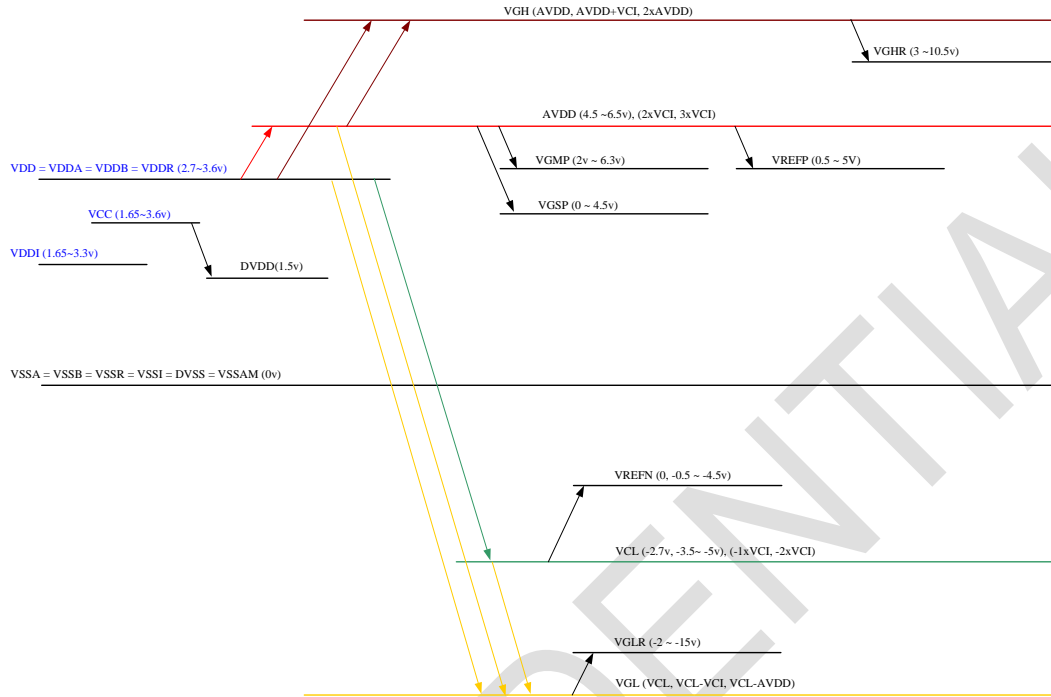

8.2 DC/DC Converter Circuit

2PWR(VDDI, VDD)
VDD=VDDA=VDDR=VDDB
AVDD/VCL → internal CP

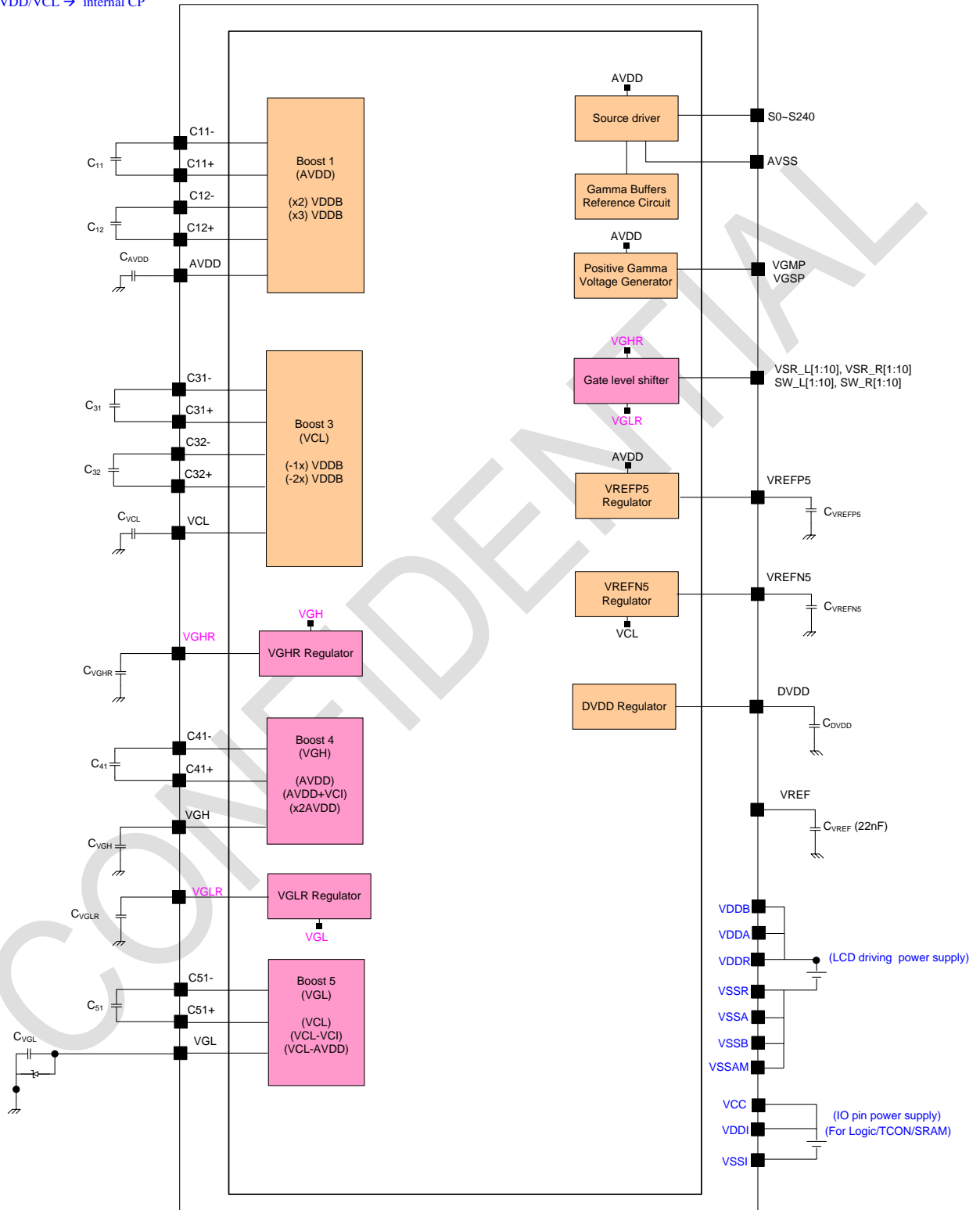

8.3 External Components

No.	Signal name	Values	Max ability
1	VDDA, VDDR, VDDB	Cap , 2.2uF	6.3V
2	VDDI, VCC	Cap , 2.2uF	6.3V
3	VREF	Cap , 22nF	6.3V
4	DVDD	Cap , 1.0uF	6.3V
5	VREFN/VREFP	Cap , 1.0uF	6.3V
6	VGHR	Cap , 1.0uF	16V
7	VGLR	Cap , 1.0uF	16V
8	BVP3D	Cap , 2.2uF	10V
9	BVN3D	Cap , 2.2uF	10V
10	C11P/C11N	Cap , 1.0uF	6.3V
11	C12P/C12N	Cap , 1.0uF	6.3V
12	AVDD	Cap , 2.2uF	10V
13	C31P/C31N	Cap , 1.0uF	6.3V
14	C32P/C32N	Cap , 1.0uF	6.3V
15	VCL	Cap , 2.2uF	6.3V
16	C41P/C41N	Cap , 1.0uF	16V
17	VGH	Cap , 2.2uF	25V
18	C51P/C51N	Cap , 1.0uF	16V
19	VGL	Cap , 2.2uF	25V
20	VGL (VGL-GND)	Schottky Diode	

8.5 Power Level Modes

Normal display mode on = NORON

Partial mode on = PTLON

Idle mode off = IDMOFF

Idle mode on = IDMON

Sleep out = SLPOUT

Sleep in = SLPIN

Deep standby mode = DSTBON

Definition example:

1. Normal Mode On (full display), Idle Mode Off, Sleep Out.

In this mode, the display is able to show maximum 16.7M colors.

2. Partial Mode On, Idle Mode Off, Sleep Out

In this mode, part of the display is used with maximum 16.7M colors.

3. Normal Mode On (full display), Idle Mode On, Sleep Out.

In this mode, the full display is used but with 8 colors.

4. Partial Mode On, Idle Mode On, Sleep Out

In this mode, part of the display is used but with 8 colors.

5. Sleep In Mode.

In this mode, the DC/DC converter, internal oscillator and panel driver circuit are stopped. Only the MPU interface and registers are working with VDDI power supply. Contents of the frame memory can be safe or random.

6. Deep Standby Mode.

In this mode, the DC/DC converter, internal oscillator and panel driver circuit are stopped. The MPU interface and registers are not working. Contents of the frame memory are random.

7. Power Off Mode

In this mode, VDDI and VDDA/VDDR/VDDB are removed.

NOTE: Transition between mode 1~5 is controllable by MPU commands. Mode 6 is entered for power saving with both power supplies for I/O and analog circuits and can be exited by hardware reset only (RESX=L). Mode 7 is entered only when both power supplies for I/O and analog circuits are removed.

8.6 Maximum Series Resistance

Pin Name	Type	Max Resistance	Unit
VDDA, VDDDB, VDDR, VDDI, VCC,	Power Supply	5	Ω
AVSS, VSSAM, DVSS, VSSI, VSSA, VSSR, VSSB	Power Supply	5	Ω
AVDD	Power Input/Output	5	Ω
DVDD	Power Output	5	Ω
VCL	Power Output	5	Ω
VGH, VGL	Power Output	10	Ω
C11P/N~C12P/N	Capacitor Connection	5	Ω
C31P/N~C32P/N	Capacitor Connection	5	Ω
C41P/N	Capacitor Connection	5	Ω
C51P/N	Capacitor Connection	5	Ω
HSSI_CLK_P/N, HSSI_DATA0_P/N, HSSI_DATA1_P/N,	MIPI Interface I/O	5	Ω
TE, SWIRE, OLED_EN	Digital Output I/O	20	Ω
RESX, CSX, D/CX, SCL, SDI, SDO	Digital Interface I/O	20	Ω
IM[1 :0], DSWAP, PSWAP	Input I/O	100	Ω
MTP_PWR	Power Supply	5	Ω
S[1]~S[240]	Source output	20	Ω
VSR_L[1]~ VSR_L[10], VSR_R[1]~ VSR_R[10] SW_L[1]~ SW_L[10], SW_R[1]~ SW_R[10]	GOA,SWoutput	20	Ω

9. Pad Diagram and Coordination

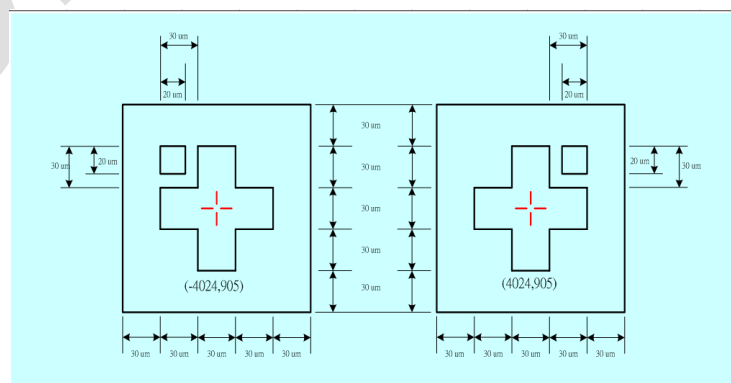
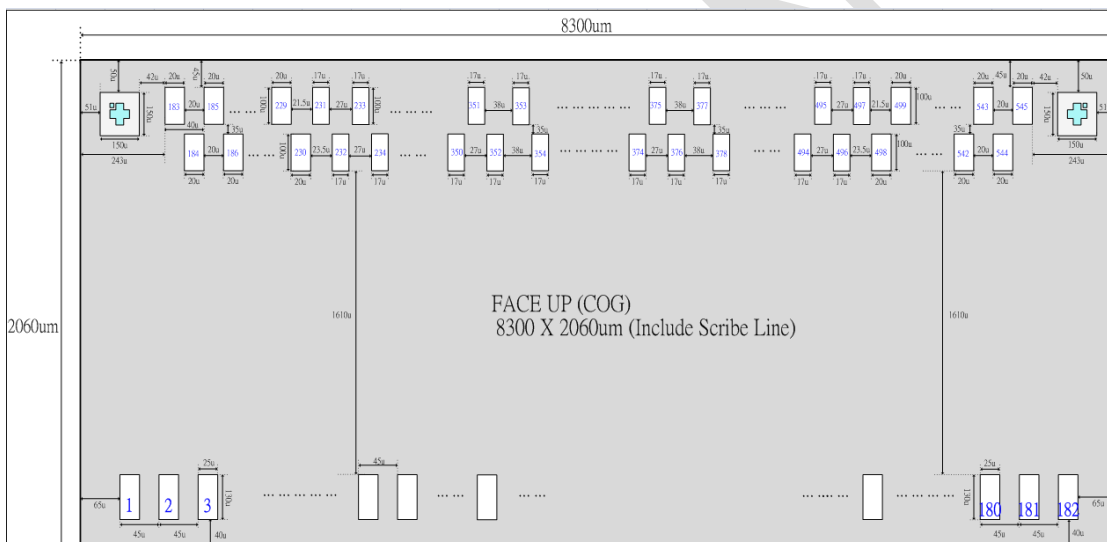
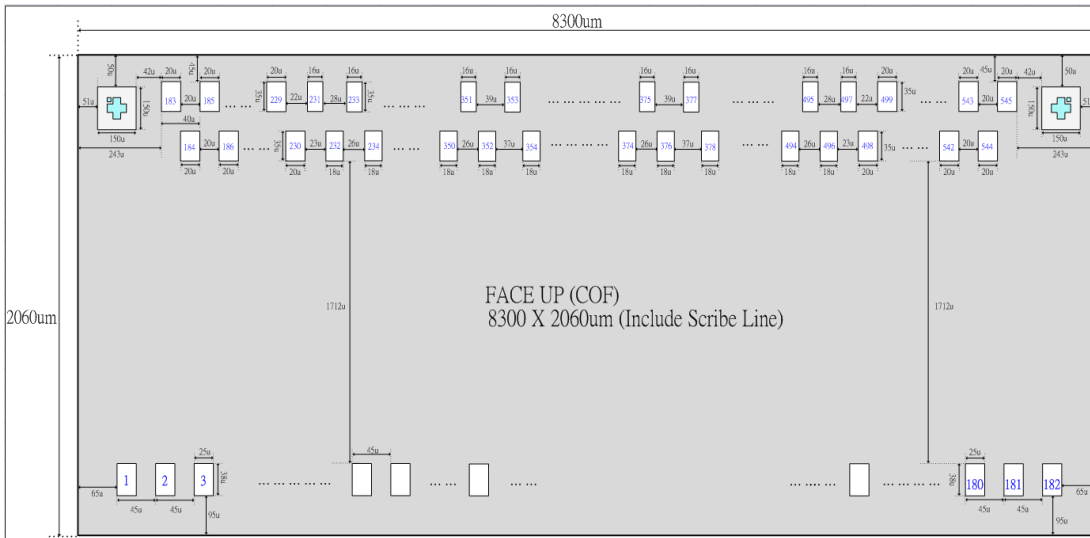

- Chip size: 8300 um x 2060um (Include sealing and scribe line)
- Chip thickness: 200/300 um
- PAD coordinates: PAD center
- PAD coordinates origin: Chip center
- Au bump size
 1. 16um x 35um(COF)/17um x 100um(COG): Source:S1~S240
 2. 20um x 35um(COF)/20um x 100um(COG): gate control signal
 3. 25um x 38um(COF)/25um x 130um(COG): Input Pads
- Au bump pitch: See PAD coordinates table
- Au bump height: 12 ± 2 um (typ.)
- No. in the figure corresponds to No. in the PAD coordinates table
- Alignment mark

Alignment mark shape	X	Y
left	4024	905
right	-4024	905

-

CONFIDENTIAL

■ Pad Coordinate (Unit: um)

NO	PAD NAME						
1	ANALOG_TEST[1]	51	D[0]	101	VSSR	151	C32N
2	VGLR	52	VSSI	102	VSSR	152	C32N
3	VGLR	53	D[1]	103	VSSA	153	C41P
4	VGHR	54	D[2]	104	VSSA	154	C41P
5	VGHR	55	D[3]	105	VSSA	155	C41N
6	VREFP5	56	D[4]	106	AVSS	156	C41N
7	VREFP5	57	D[5]	107	AVSS	157	C51N
8	VREFP5	58	VSSI	108	AVSS	158	C51N
9	VREFN5	59	D[6]	109	VSSB	159	C51P
10	VREFN5	60	D[7]	110	VSSB	160	C51P
11	VREFN5	61	TEST[1]	111	VSSB	161	VGH
12	BVP3D	62	EXTCLK	112	VSSB	162	VGH
13	BVP3D	63	TEST[2]	113	VSSB	163	VGH
14	BVP3D	64	VSSI	114	C11P	164	VGHR
15	BVN3D	65	TEST[3]	115	C11P	165	VGHR
16	BVN3D	66	IM[1]	116	C11P	166	VGHR
17	BVN3D	67	IM[0]	117	C11N	167	VGLR
18	VCL	68	DSWAP	118	C11N	168	VGLR
19	VCL	69	TESTEN	119	C11N	169	VGLR
20	VCL	70	PSWAP	120	C12P	170	VGL
21	AVDD	71	BSTM	121	C12P	171	VGL
22	AVDD	72	VDDI	122	C12P	172	VGL
23	AVDD	73	VDDI	123	C12N	173	AVSS
24	VREF	74	VDDI	124	C12N	174	AVSS
25	VGSP	75	VCC	125	C12N	175	AVSS
26	VGMP	76	VCC	126	VDDB	176	MTP_PWR
27	ANALOG_TEST[2]	77	VCC	127	VDDB	177	MTP_PWR
28	VDDR	78	DVDD	128	VDDB	178	MTP_PWR
29	VDDR	79	DVDD	129	VDDB	179	MTP_PWR
30	VDDR	80	DVDD	130	VDDB	180	MTP_PWR
31	VDDA	81	DVDD	131	VDDR	181	MTP_PWR
32	VDDA	82	DVSS	132	VDDR	182	DUMMY
33	VDDA	83	DVSS	133	VDDR	183	VGLR
34	AVSS	84	DVSS	134	VDDR	184	VGLR
35	AVSS	85	DVSS	135	AVDD	185	VGHR
36	AVSS	86	HSSI_D1_P	136	AVDD	186	VGHR
37	VSSR	87	HSSI_D1_P	137	AVDD	187	VREFP5
38	VSSR	88	HSSI_D1_N	138	C31P	188	VREFP5
39	VSSR	89	HSSI_D1_N	139	C31P	189	VREFN5
40	TE1	90	VSSAM	140	C31P	190	VREFN5
41	SWIRE	91	HSSI_CLK_P	141	C31N	191	VSR_L[10]
42	OLED_EN	92	HSSI_CLK_P	142	C31N	192	VSR_L[10]
43	TE	93	HSSI_CLK_N	143	C31N	193	VSR_L[9]
44	RESX	94	HSSI_CLK_N	144	VCL	194	VSR_L[9]
45	SDO	95	VSSAM	145	VCL	195	VSR_L[8]
46	VSSI	96	HSSI_D0_P	146	VCL	196	VSR_L[8]
47	SDI_RDX	97	HSSI_D0_P	147	C32P	197	VSR_L[7]
48	DCX	98	HSSI_D0_N	148	C32P	198	VSR_L[7]
49	WRX_SCL	99	HSSI_D0_N	149	C32P	199	VSR_L[6]
50	CSX	100	VSSR	150	C32N	200	VSR_L[6]

201	VSR_L[5]	251	S[221]	301	S[171]	351	S[121]
202	VSR_L[5]	252	S[220]	302	S[170]	352	VGHR
203	VSR_L[4]	253	S[219]	303	S[169]	353	VGLR
204	VSR_L[4]	254	S[218]	304	S[168]	354	VREFN5
205	VSR_L[3]	255	S[217]	305	S[167]	355	SDMY[1]
206	VSR_L[3]	256	S[216]	306	S[166]	356	SDMY[2]
207	VSR_L[2]	257	S[215]	307	S[165]	357	SDMY[3]
208	VSR_L[2]	258	S[214]	308	S[164]	358	SDMY[4]
209	VSR_L[1]	259	S[213]	309	S[163]	359	SDMY[5]
210	VSR_L[1]	260	S[212]	310	S[162]	360	SDMY[6]
211	SW_L[1]	261	S[211]	311	S[161]	361	SDMY[7]
212	SW_L[1]	262	S[210]	312	S[160]	362	SDMY[8]
213	SW_L[2]	263	S[209]	313	S[159]	363	SDMY[9]
214	SW_L[2]	264	S[208]	314	S[158]	364	SDMY[10]
215	SW_L[3]	265	S[207]	315	S[157]	365	SDMY[11]
216	SW_L[3]	266	S[206]	316	S[156]	366	SDMY[12]
217	SW_L[4]	267	S[205]	317	S[155]	367	SDMY[13]
218	SW_L[4]	268	S[204]	318	S[154]	368	SDMY[14]
219	SW_L[5]	269	S[203]	319	S[153]	369	SDMY[15]
220	SW_L[5]	270	S[202]	320	S[152]	370	SDMY[16]
221	SW_L[6]	271	S[201]	321	S[151]	371	SDMY[17]
222	SW_L[6]	272	S[200]	322	S[150]	372	SDMY[18]
223	SW_L[7]	273	S[199]	323	S[149]	373	SDMY[19]
224	SW_L[7]	274	S[198]	324	S[148]	374	SDMY[20]
225	SW_L[8]	275	S[197]	325	S[147]	375	VREFP5
226	SW_L[8]	276	S[196]	326	S[146]	376	VGLR
227	SW_L[9]	277	S[195]	327	S[145]	377	VGHR
228	SW_L[9]	278	S[194]	328	S[144]	378	S[120]
229	SW_L[10]	279	S[193]	329	S[143]	379	S[119]
230	SW_L[10]	280	S[192]	330	S[142]	380	S[118]
231	SDMY[21]	281	S[191]	331	S[141]	381	S[117]
232	S[240]	282	S[190]	332	S[140]	382	S[116]
233	S[239]	283	S[189]	333	S[139]	383	S[115]
234	S[238]	284	S[188]	334	S[138]	384	S[114]
235	S[237]	285	S[187]	335	S[137]	385	S[113]
236	S[236]	286	S[186]	336	S[136]	386	S[112]
237	S[235]	287	S[185]	337	S[135]	387	S[111]
238	S[234]	288	S[184]	338	S[134]	388	S[110]
239	S[233]	289	S[183]	339	S[133]	389	S[109]
240	S[232]	290	S[182]	340	S[132]	390	S[108]
241	S[231]	291	S[181]	341	S[131]	391	S[107]
242	S[230]	292	S[180]	342	S[130]	392	S[106]
243	S[229]	293	S[179]	343	S[129]	393	S[105]
244	S[228]	294	S[178]	344	S[128]	394	S[104]
245	S[227]	295	S[177]	345	S[127]	395	S[103]
246	S[226]	296	S[176]	346	S[126]	396	S[102]
247	S[225]	297	S[175]	347	S[125]	397	S[101]
248	S[224]	298	S[174]	348	S[124]	398	S[100]
249	S[223]	299	S[173]	349	S[123]	399	S[99]
250	S[222]	300	S[172]	350	S[122]	400	S[98]

401	S[97]
402	S[96]
403	S[95]
404	S[94]
405	S[93]
406	S[92]
407	S[91]
408	S[90]
409	S[89]
410	S[88]
411	S[87]
412	S[86]
413	S[85]
414	S[84]
415	S[83]
416	S[82]
417	S[81]
418	S[80]
419	S[79]
420	S[78]
421	S[77]
422	S[76]
423	S[75]
424	S[74]
425	S[73]
426	S[72]
427	S[71]
428	S[70]
429	S[69]
430	S[68]
431	S[67]
432	S[66]
433	S[65]
434	S[64]
435	S[63]
436	S[62]
437	S[61]
438	S[60]
439	S[59]
440	S[58]
441	S[57]
442	S[56]
443	S[55]
444	S[54]
445	S[53]
446	S[52]
447	S[51]
448	S[50]
449	S[49]
450	S[48]

451	S[47]
452	S[46]
453	S[45]
454	S[44]
455	S[43]
456	S[42]
457	S[41]
458	S[40]
459	S[39]
460	S[38]
461	S[37]
462	S[36]
463	S[35]
464	S[34]
465	S[33]
466	S[32]
467	S[31]
468	S[30]
469	S[29]
470	S[28]
471	S[27]
472	S[26]
473	S[25]
474	S[24]
475	S[23]
476	S[22]
477	S[21]
478	S[20]
479	S[19]
480	S[18]
481	S[17]
482	S[16]
483	S[15]
484	S[14]
485	S[13]
486	S[12]
487	S[11]
488	S[10]
489	S[9]
490	S[8]
491	S[7]
492	S[6]
493	S[5]
494	S[4]
495	S[3]
496	S[2]
497	S[1]
498	SW_R[10]
499	SW_R[10]
500	SW_R[9]

501	SW_R[9]
502	SW_R[8]
503	SW_R[8]
504	SW_R[7]
505	SW_R[7]
506	SW_R[6]
507	SW_R[6]
508	SW_R[5]
509	SW_R[5]
510	SW_R[4]
511	SW_R[4]
512	SW_R[3]
513	SW_R[3]
514	SW_R[2]
515	SW_R[2]
516	SW_R[1]
517	SW_R[1]
518	VSR_R[1]
519	VSR_R[1]
520	VSR_R[2]
521	VSR_R[2]
522	VSR_R[3]
523	VSR_R[3]
524	VSR_R[4]
525	VSR_R[4]
526	VSR_R[5]
527	VSR_R[5]
528	VSR_R[6]
529	VSR_R[6]
530	VSR_R[7]
531	VSR_R[7]
532	VSR_R[8]
533	VSR_R[8]
534	VSR_R[9]
535	VSR_R[9]
536	VSR_R[10]
537	VSR_R[10]
538	VREFN5
539	VREFN5
540	VREFP5
541	VREFP5
542	VGHR
543	VGHR
544	VGLR
545	VGLR