



DM-TFTR247-469

2.47" 480 X 480 Round 16.7M Transmissive TFT - RGB

CONTENT LIST

Cover	1
Content List	2
Record of Revisions	3
1. General Description	4
2. Absolute Maximum Ratings	6
3. Electrical Specifications	7
4. Interface Connection	9
5. Signal Timing Specification	11
6. Power ON/OFF Sequence	12
7. Optical Specifications	13
8. Mechanical Characteristics	16
9. Reliability Test	18
10. Packing Method	19
11. Product ID Rule	22
12. Handling & Cautions	23
13. Applicable Scope	25

1.0 GENERAL DESCRIPTION

1.1 Introduction

DM-TFTR247-469 is a color active matrix TFT-LCD Panel using amorphous silicon TFT's (Thin Film Transistors) as an active switching devices. This model is composed of a TFT-LCD Panel, a driving circuit and a back light system. It is a transmissive type display operating in the normal black. This TFT-LCD has a 2.47 inch diagonally measured active area with Z6 resolutions (480 horizontal by 480 vertical pixel array). Each pixel is divided into Red, Green, Blue dots which are arranged in 2 domain stripe and this panel can display 16.7M colors.

1.2 Features

- 0.4t Glass (Single)
- Thin and light weight
- High luminance and contrast ratio, wide viewing angle
- Module Design
- RoHS Compliant

1.3 Application

- Healthcare & Industrial

1.4 General Specifications (H: horizontal length, V: vertical length)

Parameter	Specification	Unit	Remark
Active Area	62.64 × 62.64(circle)	mm	
Number of Pixels	480RGB × 480	pixels	
Pixel Pitch	130.5(H) × 130.5(V)	um	
Pixel Arrangement	RGB 2domain stripe		
Display Colors	16.7 M	colors	
Color Gamut	70%(typ.)		
Display Mode	Normally Black, Transmissive mode		
Dimensional Outline	69.19±0.2(H) × 71.74±0.2(V) × 2.45±0.15(D)	mm	No with Component and FPC
Viewing Direction (Human Eye)	U/D/L/R free viewing direction		Note 1,2
D-IC	HX8379-C		
Weight	25g (Max)	gram	

Note:

1. At the U/D/L/R direction, the viewing angle is same;
2. The TFT and CF LC Algin Direction;

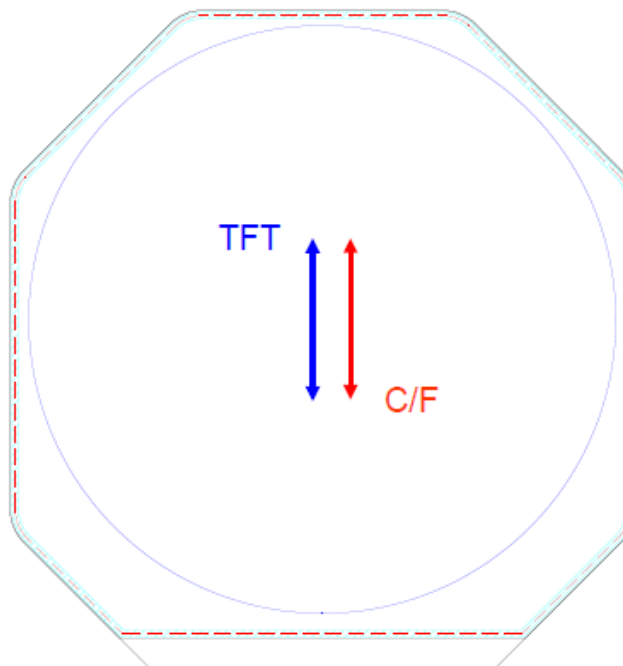

2.0 ABSOLUTE MAXIMUM RATINGS

The absolute maximum ratings are list on table as follows. When used out of the absolute maximum ratings, the LSI may be permanently damaged. Using the LSI within the following electrical characteristics limit is strongly recommended for normal operation. If these electrical characteristic conditions are exceeded during normal operation, the LSI will malfunction and cause poor reliability.

Parameter	Symbol	Value	Unit
Supply voltage for I/O and interface	IOVCC	-0.3~+3.6	V
Supply voltage for logic and analog	VCI	-0.3~+3.6	V
Operating temperature range	T _{OPR}	-10 ~ 60	°C
Storage Temperature range	T _{STG}	-30 ~ 70	°C
High temperature / Humidity	-	60°C/ 90%	°C / %

Note:

If the absolute maximum rating of even is one of the above parameters is exceeded even momentarily, the quality of the product may be degraded. Absolute maximum ratings, therefore, specify the values exceeding which the product may be physically damaged. Be sure to use the product within the range of the absolute maximum ratings.

3.0 ELECTRICAL SPECIFICATIONS

3.1 TFT LCD Module DC Characteristics

Parameter	Symbol	Min	Typ	Max	Unit	Remark
I/O and interface Supply Voltage	IOVCC	1.65	1.8	3.3	V	-
Logic and Analog Supply Voltage	VCI	2.5	3.3	3.6	V	-
Logic Low Voltage	VIL	0		0.3IOVCC	V	
Logic High Voltage	VIH	0.7IOVCC		IOVCC	V	
Power Consumption	Normal Mode	-	80	135	mW	Note
	Standby Mode	-	260	-	uW	

Note:

Frame rate=60HZ,Column Inversion, Temperature=25°C.

3.2 Backlight Driving Conditions

Parameter	Symbol	Min	Typ	Max	Unit	Remark
LED Forward Voltage	V_F	8.4	9	9.6	V	$V_F=3*3V$
LED Forward Current	I_F	35.8	36	36.2	mA	$I_F=2*18mA$
LED Power Consumption	P_{LED}	-	330	350	mW	Note

Note:

- $P_{LED}=I_F \times V_F$
- Quantity of LED: 2line x 3LEDs per line = 6 LEDs

3.3 Block Diagram

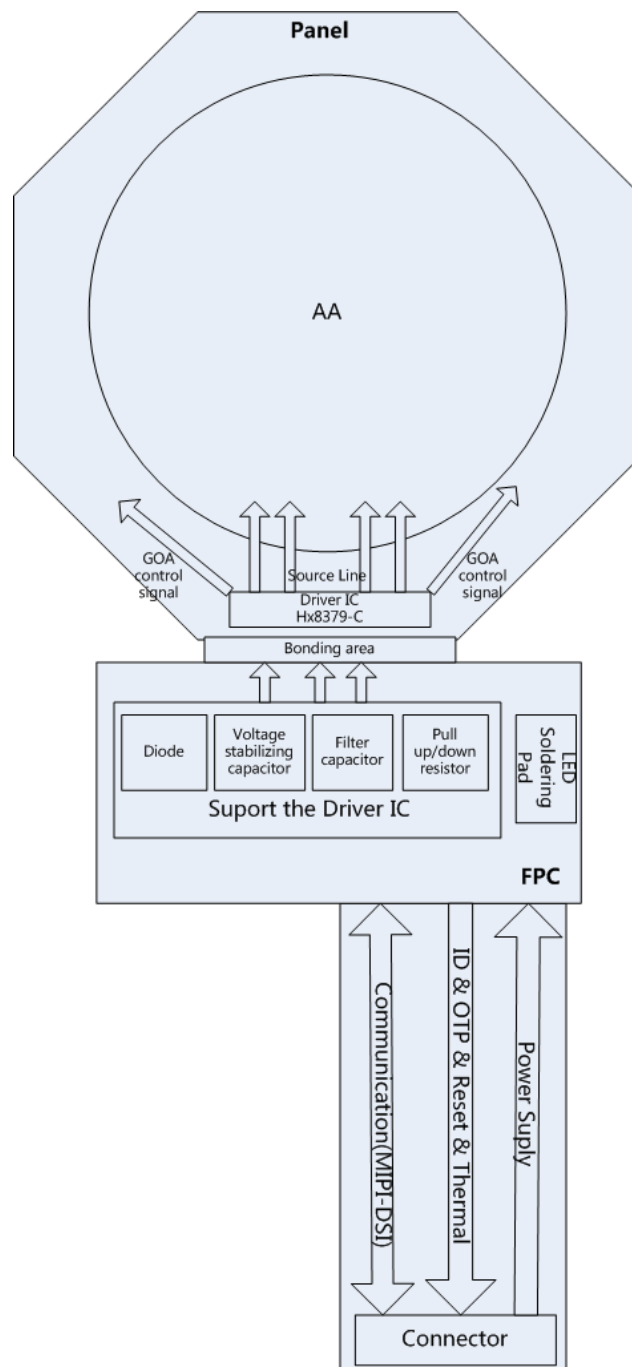

4.0 INTERFACE CONNECTION

4.1 FPC Connector Pin map

PIN#	Pin Name	Pin Description
1	GND	Ground
2	DSI_D1P	MIPI DSI : Data differential signal input pins. (Data lane 1 positive)
3	NC	NC
4	DSI_D1N	MIPI DSI : Data differential signal input pins. (Data lane 1 negative)
5	GND	Ground
6	GND	Ground
7	GND	Ground
8	DSI_CP	MIPI DSI : clock differential signal input pins. (Clock lane positive)
9	NC	NC
10	DSI_CN	MIPI DSI : clock differential signal input pins. (Clock lane negative)
11	GND	Ground
12	GND	Ground
13	GND	Ground
14	DSI_D0P	MIPI DSI : Data differential signal input pins. (Data lane 0 positive)
15	NC	NC
16	DSI_D0N	MIPI DSI : Data differential signal input pins. (Data lane 0 negative)
17	GND	Ground
18	GND	Ground
19	ID0	Display ID0 (0V/ 1.8V) - Add pull up/down Resistor
20	ID1	Display ID1 (0V/ 1.8V) - Add pull up/down Resistor
21	RST	Display Reset
22	NC	Vendor to use as OTP
23	THERM	Thermistor Readout
24	IOVCC	1.8V, Power supply for logic and I/O circuits
25	GND	Ground to avoid power supply noise interference
26	VCI	3.3V, Power supply for analog circuits
27		
28	GND	Ground to avoid power supply noise interference
29	LED1-	Power supply for LED1-
30	LED2-	Power supply for LED2-
31	NC	
32	LED+	Power supply for LED+
33		
34	NC	
35	GND	Ground

4.2 MIPI Characteristics

MODE	VSYNC_Width	VSYNC_BP	VSYNC_FP	HSYNC_Width	HSYNC_BP	HSYNC_FP
Event /Burst/Pulse	4-Hsync	8-Hsync	5-Hsync	(HS=100,HBP=100) HS+HBP>1.2us		(HFP=180) HFP> 1us

4.3 DC Characteristics

Parameter	Symbol	Min.	Typ.	Max.	Unit
MIPI Characteristics for High Speed Receiver					
Single-ended input low voltage	VILHS	-40	-	-	mV
Single-ended input high voltage	VIHHS	-	-	460	mV
Differential input impedance	ZID	80	100	125	ohm
HS transmit differential voltage	VOD	140	200	270	mV
MIPI Characteristics for Low Power Mode					
Pad signal voltage range	VI	-50	-	1350	mV
Ground shift	VGNDSH	-50	-	50	mV
Logic 0 input threshold	VIL	-	-	550	mV
Logic 1 input threshold	VIH	880	-	-	mV
Input hysteresis	VHYST	25	-	-	mV
Output low level	VOL	-50	-	50	mV
Output high level	VOH	1.1	1.2	1.3	V

4.4 MIPI timing

Parameter	Symbol	Min	Typ	Max
MIPI Data Frequency	Mbps	-	-	550/lane for 2-lane
Hsync period time	us	2.2	-	-
Hsync pulse width	us	0.2	-	-
Hsync back porch	us	1	-	-
Hsync front porch	us	1	-	-
Vsync period time	line	6	-	-
Vsync pulse width	line	2	-	255
Vsync back porch	line	2	-	255
Vsync front porch	line	2	-	-
Data to CLK Setup Time	UIINST	0.15	-	-
Data to CLK Hold Time	UIINST	0.15	-	-
Data CLK cycle time	ns	1.82	-	12.5

5.0 SIGNAL TIMING SPECIFICATION

5.1 Vertical timings

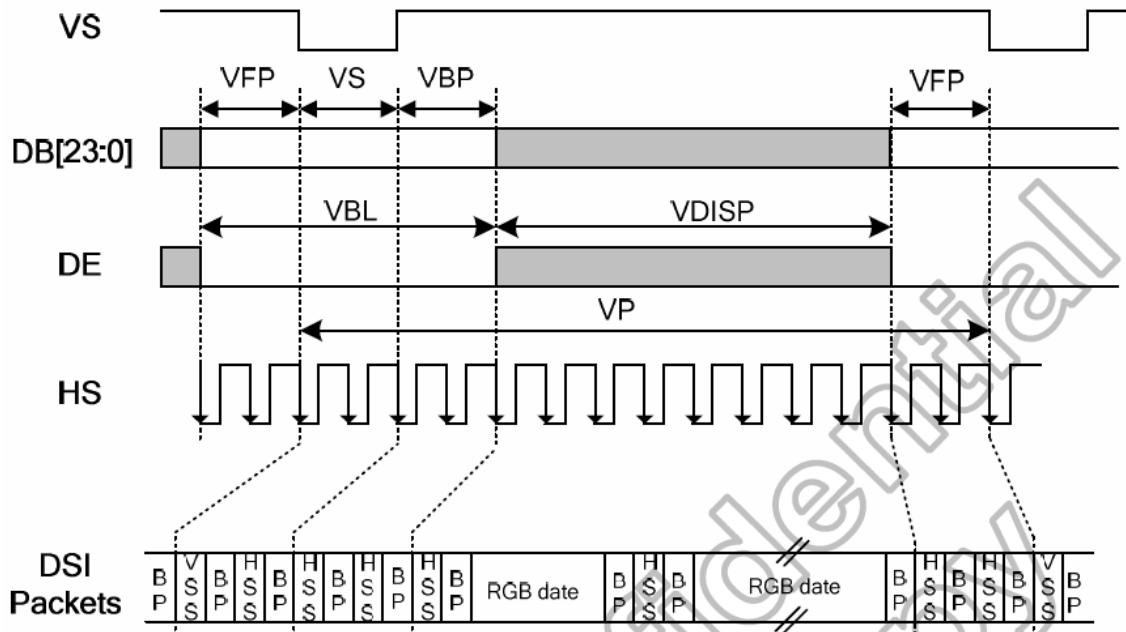

5.2 Horizontal timings

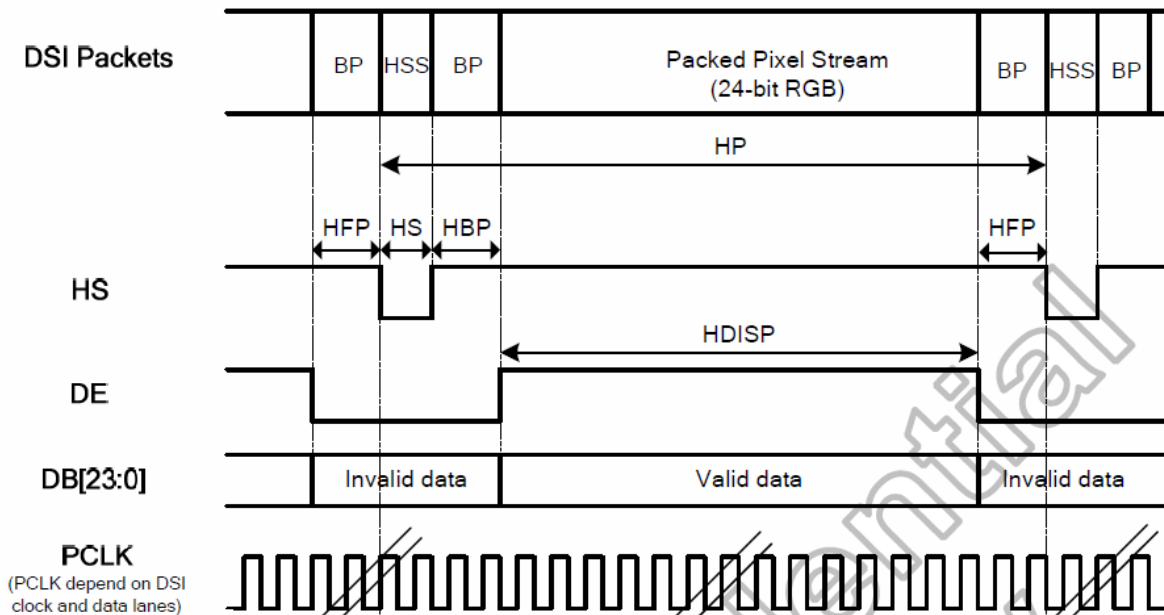

6.0 POWER ON/OFF SEQUENCE

6.1 Power on sequence

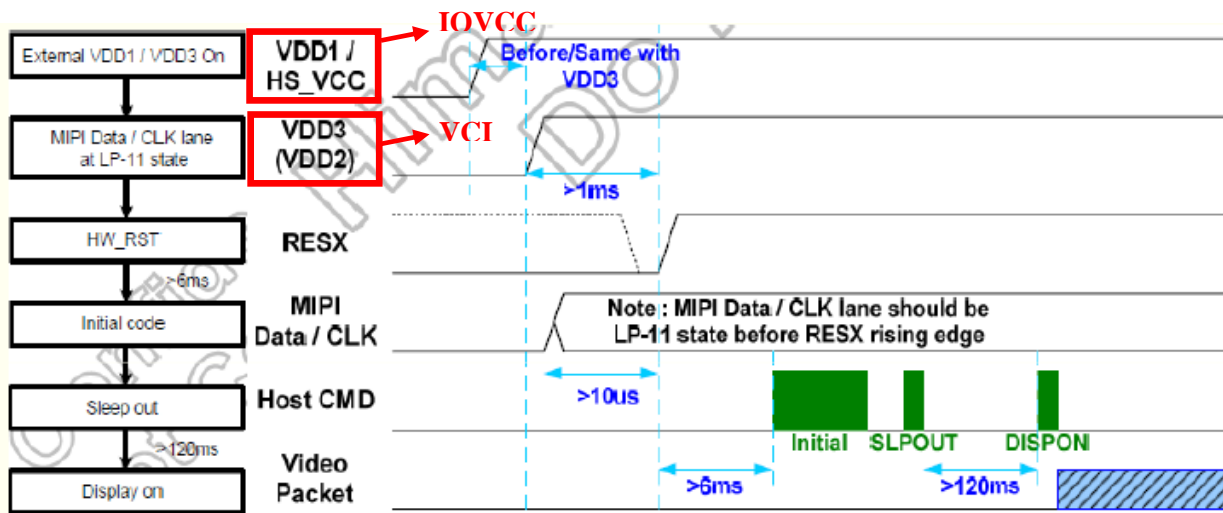

6.2 Power off sequence

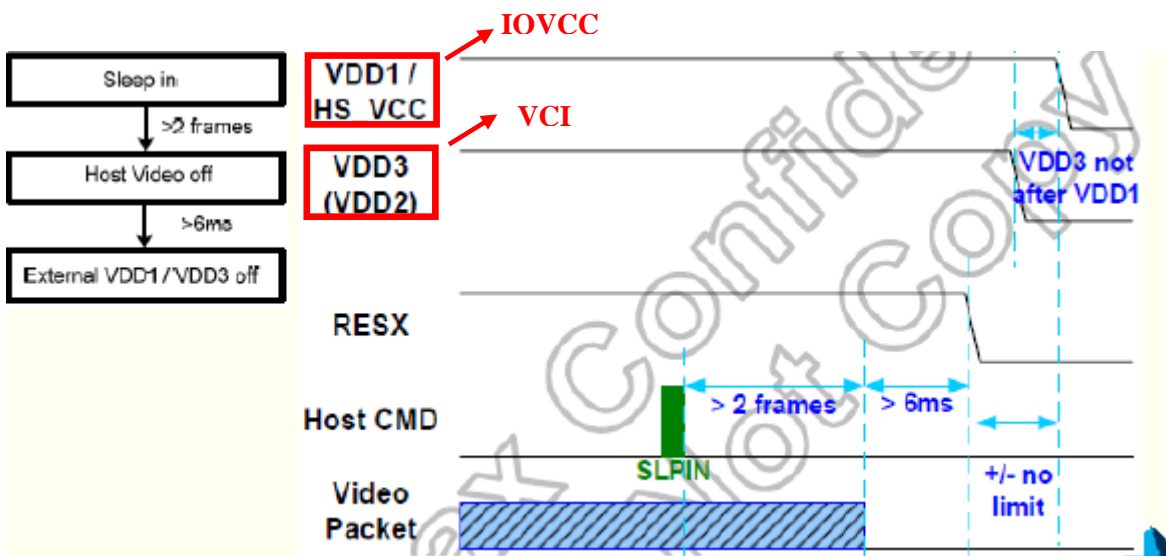

7.0 OPTICAL SPECIFICATIONS

7.1 Overview

The test of Optical specifications shall be measured in a dark room (ambient luminance ≤ 1 lux and temperature = $25 \pm 2^\circ\text{C}$) with the equipment of Luminance meter system (Topcon SR-UL1R and Westar TRD-100A) and test unit shall be located at an approximate distance 50cm from the LCD surface at a viewing angle of θ and Φ equal to 0° . The center of the measuring spot on the Display surface shall stay fixed.

The backlight should be operating for 30 minutes prior to measurement.

7.2 Optical Specifications

Parameter		Symbol	Condition	Min.	Typ.	Max.	Unit	Remark
Viewing Angle	Horizontal	$\Theta 3$	CR > 10	70	85		°	Note 1
		$\Theta 9$		70	85		°	
	Vertical	$\Theta 12$		70	85		°	
		$\Theta 6$		70	85		°	
Contrast Ratio		CR	$\Theta = 0^\circ$	800	1000			Note 2
Luminance		cd/m ²	$\Theta = 0^\circ$	350	400		nit	Note 3
Uniformity		%	$\Theta = 0^\circ$	70				Note 4
NTSC		%	$\Theta = 0^\circ$	65	70			
Reproduction Of color	Red	Rx	$\Theta = 0^\circ$	0.607	0.637	0.667		Note 5 * Module
		Ry		0.298	0.328	0.358		
	Green	Gx		0.307	0.337	0.367		
		Gy		0.592	0.622	0.652		
	Blue	Bx		0.125	0.155	0.185		
		By		0.025	0.055	0.085		
White		Wx	$\Theta = 0^\circ$	0.283	0.313	0.343		
		Wy		0.299	0.329	0.359		
Response Time		Tr+Tf	$\Theta = 0^\circ$			35	ms	Note 6

Note:

- Viewing angle is the angle at which the contrast ratio is greater than 10. The viewing are determined for the horizontal or 3, 9 o'clock direction and the vertical or 6, 12 o'clock direction with respect to the optical axis which is normal to the LCD surface (see FIG.1).
- Contrast measurements shall be made at viewing angle of $\Theta = 0^\circ$ and at the center of the LCD surface. Luminance shall be measured with all pixels in the view field set first to white, then to the dark (black) state. (See FIG. 1) Luminance Contrast Ratio (CR) is defined mathematically.

$$\text{CR} = \frac{\text{Luminance when displaying a white raster}}{\text{Luminance when displaying a black raster}}$$

- Surface luminance is the center point across the LCD surface 50cm from the surface with all pixels displaying white. This measurement shall be taken at the locations shown in FIG. 1.

4. Uniformity measurement shall be taken at the locations shown in FIG. 1&2, for a total of the measurements per display, measure surface luminance of these nine points across the LCD surface 50cm from the surface with all pixels displaying white.

$$\text{Uniformity} = \frac{\text{Min Luminance of 13 points}}{\text{Max Luminance of 13 points}} \times 100\%$$

5. The color chromaticity coordinates specified in Table1 shall be calculated from The spectral data measured with all pixels first in red, green, blue and white. Measurements shall be made at the center of the Module.

6. The electro-optical response time measurements shall be made as FIG.3 by switching the "data" input signal ON and OFF.

The times needed for the luminance to change from 10% to 90% is Tr and 90% to 10% is Tf.

Fig

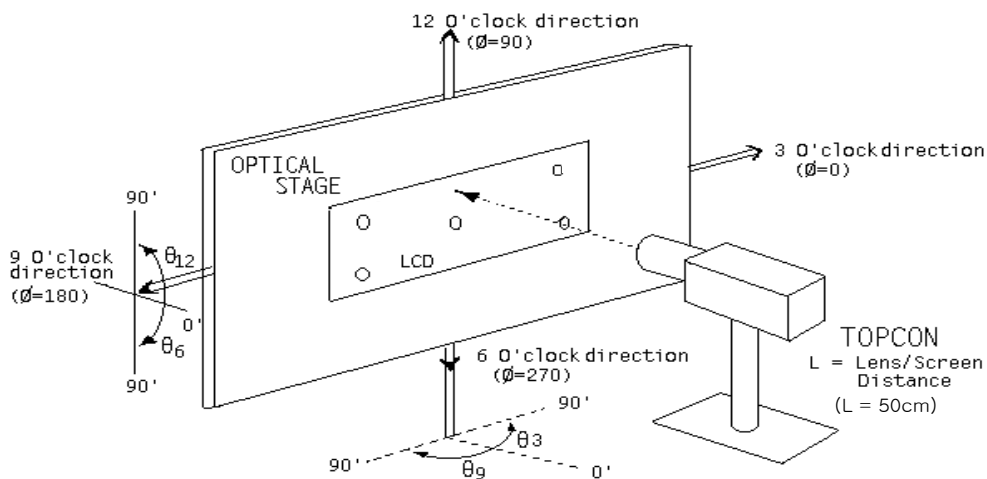

Fig

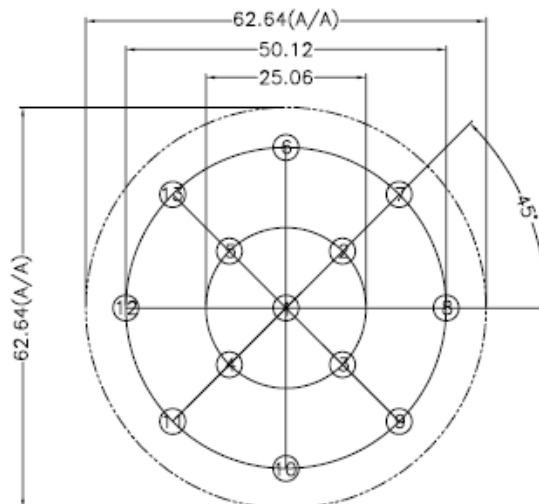
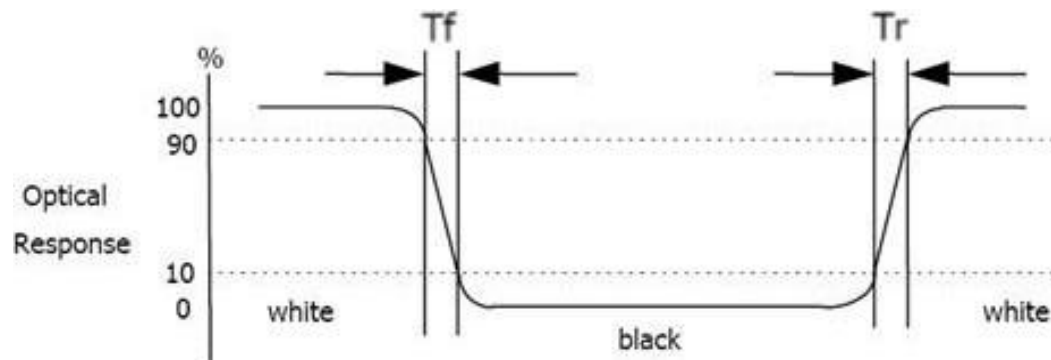

Figure 3. Response Time Testing

8.0 MECHANICAL CHARACTERISTICS

8.1 Dimension Requirements for MDL Part

Mechanical outlines for the panel (H: horizontal length, V: Vertical length)

Parameter	Specification	Unit	Remark
Panel size	70.14(V) X 66.64(H)	mm	
Active area	62.64 × 62.64(circle)	mm	
Number of pixels	480RGB × 480	pixels	
	(1 pixel = R + G + B dots)		
Dimensional outline	69.19±0.2(H) × 71.74±0.2(V) × 2.45±0.15(D)	mm	Module
Display mode	Normally Black		

Figure 5. LCM Outline Dimension (unit: mm)

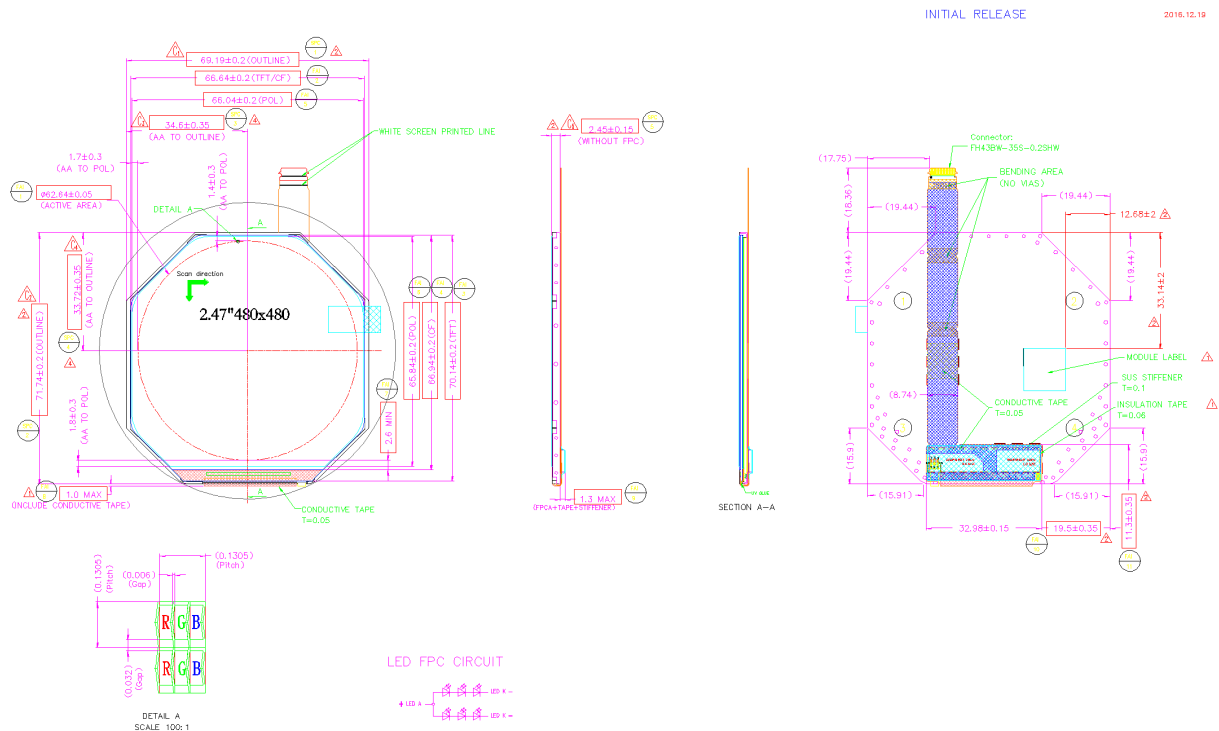
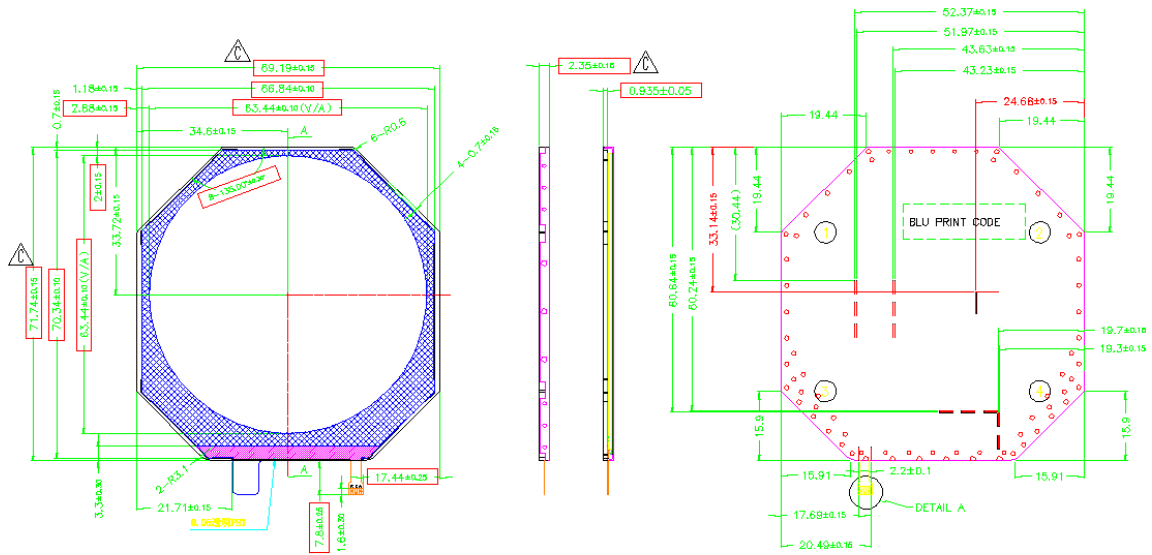

Figure 6. BLU Outline Dimension (unit: mm)

INITIAL RELEASE

2017.06.31

CHEN JA



LED FPC CIRCUIT

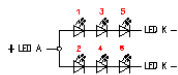

CONFIDENTI-L

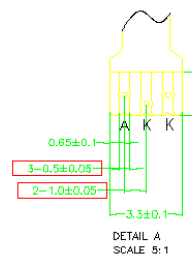
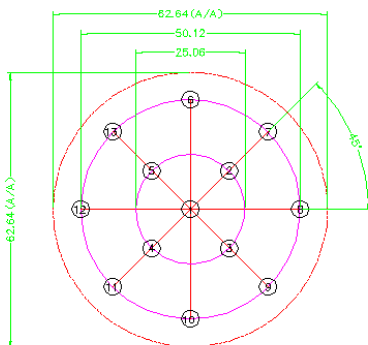

13 点均一性管控测试点

9.0 RELIABILITY TEST

NO.	Test Item	Test Condition	Duration
1	High temperature, high humidity operation test(THO)	60°C, 90%RH	500hrs
2	Low temperature operation test(LTO)	-10°C	240hrs
3	High temperature operation test(HTO)	60°C	240hrs
4	High temperature storage test(HTS)	70°C	240hrs
5	Low temperature storage test(LTS)	-30°C	240hrs
6	Thermal shock test (TST)	-25°C → 60°C	138 cycles 1hr/cycle
7	Shock	220 G, 2 ms ,Half Sine , 6 sides	
8	ESD	Contact ±4KV, Air ±8KV 100pF, 1500 Ω, 每点 10 次 IC 表面(左中右) ±2KV	Operating
		Contact ±4KV 100pF, 1500 Ω, 每点 10 次 IC 表面(左中右) ±2KV	Storage
9	Vibration	3.5 Grms random vibration, 5 to 500 Hz, 15 min / axis	

10.0 PACKING METHOD

10.1 Packing Tray

<Tray Size> L: 340 mm; W: 248 mm; 6pcs/tray

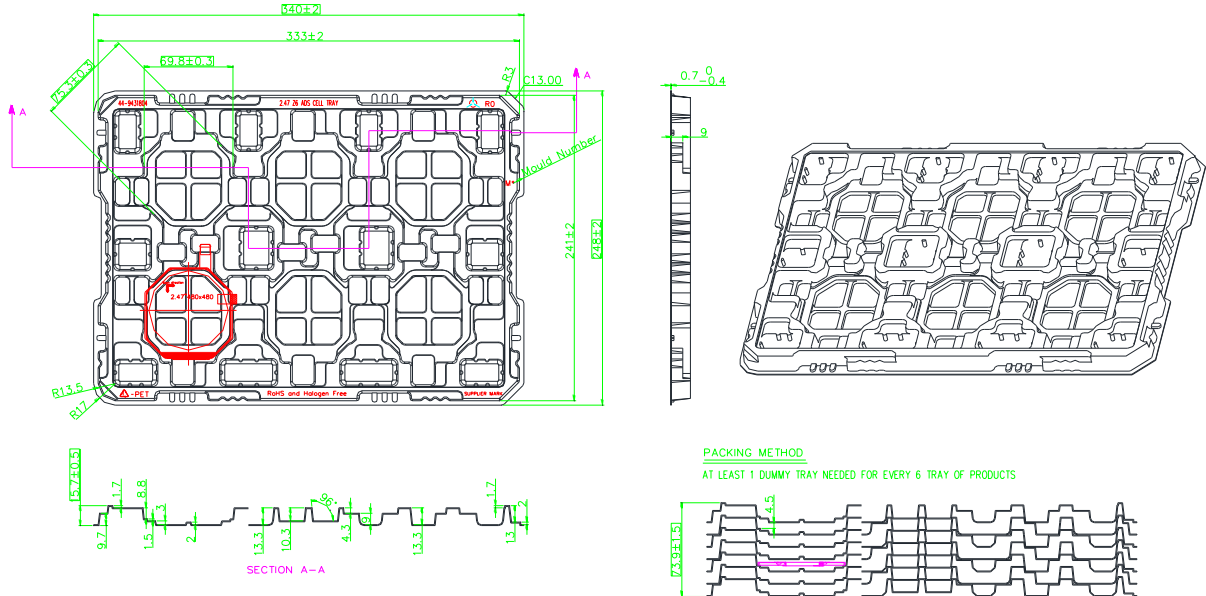

10.2 Inner Box

<Inner Box Size> L: 360mm; W: 260mm; H:80mm. (6ea Tray Product + 1ea Empty Tray)

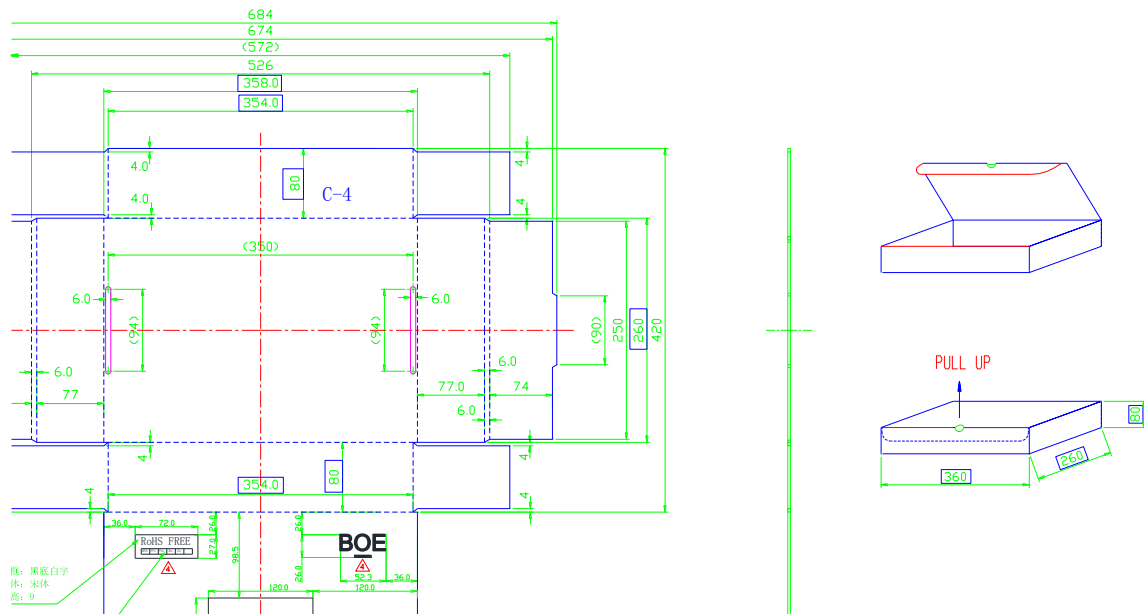

10.3 Outer Box

<Out box size> L:545mm; W:380mm; H:270mm. (6pcs inner box /Out Box)

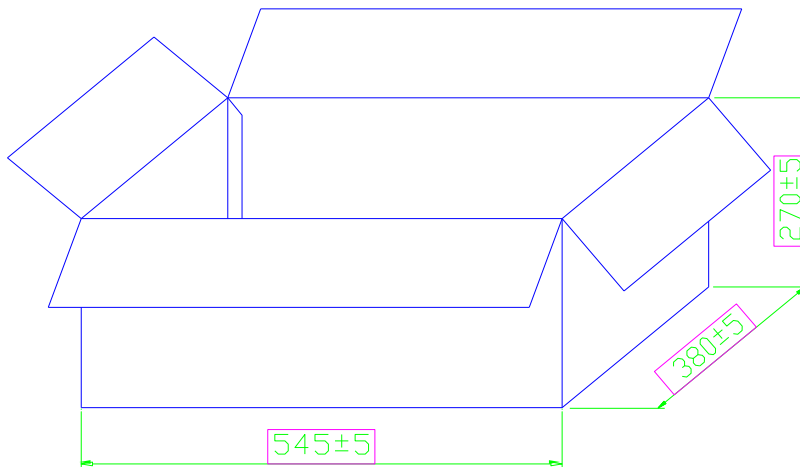
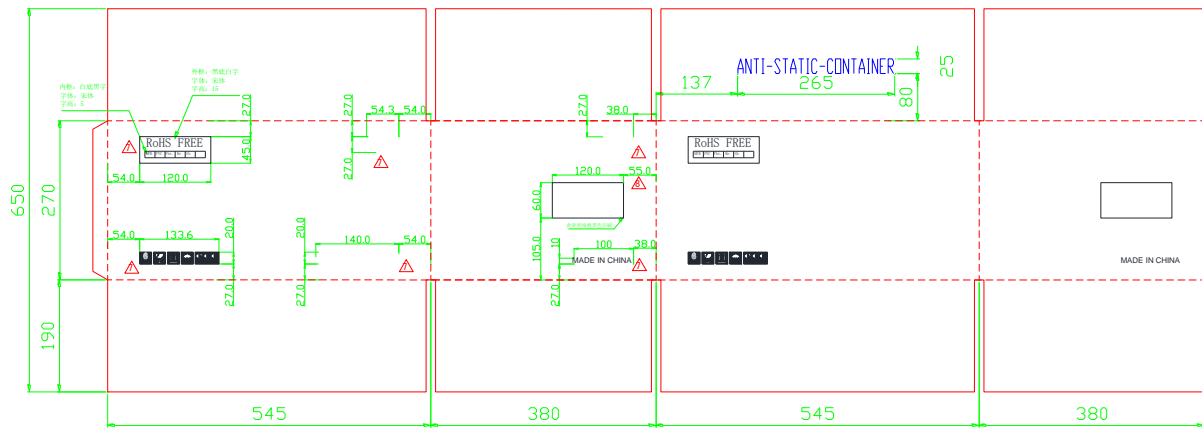

NOTE

- 1.MATERIAL: KSA 1531,DW2(T=8mm)
- 2.DRAWING DIMENSIONS ARE EQUAL TO OUTSIDE DIMENSION.
- 3.INNER BOX(C-4) ARRANGEMENT: 3STEPS X2ROWS
- 4.MARKS ARE REFER TO SEPERATE CONSULTATION.
- △ 5.PRINTING COLOR IS BLACK(PANTONE BLACK C)
- △ 6.IQC CHECK POINTS:

10.4 Packing Process

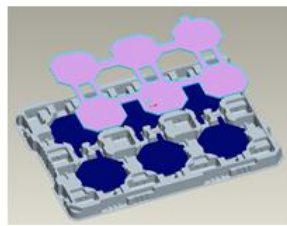

1ea pad per tray &
6ea Module per tray

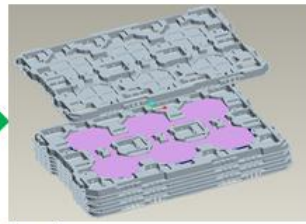

Step2 :
Turning 180° and stacking 6 layers,
Put one empty tray on it, and then
fixed with rubber band.



Step3 :
Put into vacuum bag and packing



Step5 :
Put 6 inner box into outer box

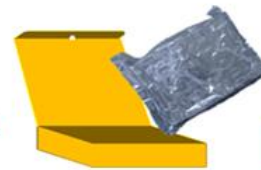

Step4 :
Put into inner box

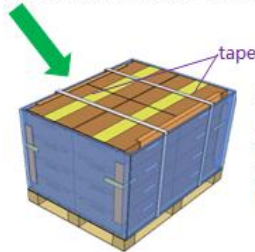

Step6 :
Placed the cardboard on pallet,
The outer box in accordance with 2×2×4 stacked on the cardboard,
In the 8-side use corrugated angle.
Fixed with bandage and wound with film.

7.5 Packing Notice

- Panel should be placed upwardly while in the tray.
- Every six full trays with a blank one while twining twice on both sides by adhesive tape.
- Every tray should be put crossly.
- Panels should be packed in a vacuum with PE (anti-ESD) bag.

11.0 PRODUCT ID RULE

PV024701SY35B							
① <Application area>		② <Mode>		③ <Size>		④ <Resolution>	
Code	Description	Code	Description	Code	Description	Code	Description
E	Healthcare Industrial	V	ADS-a Si	025	2.5"	Z6	480*480
H	TV	S	ADS-LTPS	050	5.0"	WQ	WQVGA
B	Mobile	T	TN-a Si	060	6.0"	LC	LQCIF

⑤ <Production type>		⑥ <Product state>		⑦ <Product THK>		⑧ <Product Rev>	
Code	Description	Code	Description	Code	Description	Code	Description
M	Module	J	Free form display	8	0.8mm	0	First Mode
A	Array	E		5	0.5mm	1	Second Mode
S	Q-Panel SLM	A		6	0.6mm	2	Third Mode

12.0 HANDDLING & CAUTIONS

12.1 Mounting Method

- The panel of the LCM consists of two thin glasses with polarizer which easily get damaged. So extreme care should be taken when handling the LCM.
- Excessive stress or pressure on the glass of the LCM should be avoided. Care must be taken to insure that no torsional or compressive forces are applied to the LCM unit when it is mounted.
- If the customer's set presses the main parts of the LCM, the LCM may show the abnormal display. But this phenomenon does not mean the malfunction of the LCM and should be pressed by the way of mutual agreement.
- To determine the optimum mounting angle, refer to the viewing angle range in the specification for each model.
- Mount a LCM with the specified mounting parts.

12.2 Caution of LCM Handling and Cleaning

- Since the LCM is made of glass, do not apply strong mechanical impact or static load onto it. Handling with care since shock, vibration, and careless handling may seriously affect the product. If it falls from a high place or receives a strong shock, the glass maybe broken.
- The polarizer on the surface of panel are made from organic substances. Be very careful for chemicals not to touch the polarizer or it leads the polarizer to be deteriorated.
- If the use of a chemical is unavoidable, use soft cloth with solvent recommended below to clean the LCM's surface with wipe lightly.
-IPA (Isopropyl Alcohol), Ethyl Alcohol, Tri-chloro, tri-florothane.
- Do not wipe the LCM's surface with dry or hard materials that will damage the polarizer and others. Do not use the following solvent—Water, acetone, Aromatics.
- It is recommended that the LCM be handled with soft gloves during assembly, etc.
The polarizer on the LCM's surface are vulnerable to scratch and thus to be damaged by shape particles.
- Do not drop water or any chemicals onto the LCM's surface.
- A protective film is supplied on the LCM and should be left in place until the LCM is required for operation.
- The ITO pad area needs special careful caution because it could be easily corroded. Do not contact the ITO pad area with HCFC, Soldering flux, Chlorine, Sulfur, saliva or fingerprint. To prevent from the ITO corrosion, customers are recommended that the ITO area would be covered by UV or silicon.
- Please handle FPC with care.

12.3 Caution Against Static Charge

- The LCM use C-MOS LSI drivers, so customers are recommended that any unused input terminal would be connected to Vdd or Vss, do not input any signals before power is turn on, and ground you body, work/assembly area, assembly equipments to protect against static electricity.
- Remove the protective film slowly, keeping the removing direction approximate 30-degree not vertical from panel surface, if possible, under ESD control device like ion blower, and the humidity of working room should be kept over 50%RH to reduce the risk of static charge.
- Avoid the use work clothing made of synthetic fibers. We recommend cotton clothing or other conductivity-treated fibers.
- In handling the LCM, wear non-charged material gloves. And the conducting wrist to the earth and the conducting shoes to the earth are necessary.

12.4 Caution For Operation

- It is indispensable to drive the LCM within the specified voltage limit since the higher voltage than the limit causes LCM's life shorter. An electro-chemical reaction due to DC causes undesirable deterioration of the LCM so that the use of DC drive should avoid.
- Do not connect or disconnect the LCM to or from the system when power is on.
- Never use the LCM under abnormal conditions of high temperature and high humidity.
- When expose to drastic fluctuation of temperature(hot to cold or cold to hot), the LCM may be affected; specifically, drastic temperature fluctuation from cold to hot, produces dew on the LCM's surface which may affect the operation of the polarizer on the LCM.
- Response time will be extremely delay at lower temperature than the operating temperature range and on the other hand LCM may turn black at temperature above its operational range. However those phenomenon do not mean malfunction or out of order with the LCM. The LCM will revert to normal operation once the temperature returns to the recommended temperature range for normal operation.
- Do not display the fixed pattern for a long time because it may develop image sticking due to the LCM structure. If the screen is displayed with fixed pattern, use a screen saver.
- Do not disassemble and/or re-assemble LCM module

12.5 Packaging

- Modules use LCM element, and must be treated as such.
 - Avoid intense shock and falls from a height.
 - To prevent modules from degradation, do not operate or store them exposed directly to sunshine or high temperature/humidity for long periods.

12.6 Storage

- A slight dew depositing on terminals is a cause for electro-chemical reaction resulting in terminal open circuit. Relative humidity of the environment should therefore be kept below 60%RH.
- Original protective film should be used on LCM's surface (polarizer). Adhesive type protective film should be avoided, because it may change color and/or properties of the polarizer.
- Do not store the LCM near organic solvents or corrosive gasses.
- Keep the LCM safe from vibration, shock and pressure.
- Black or white air-bubbles may be produced if the LCM is stored for long time in the lower temperature or mechanical shocks are applied onto the LCM.
- In the case of storing for a long period of time for the purpose or replacement use, the following ways are recommended.
 - Store in a polyethylene bag with sealed so as not to enter fresh air outside in it.
 - Store in a dark place where neither exposure to direct sunlight nor light is.
 - Keep temperature in the specified storage temperature range.
 - Store with no touch on polarizer surface by the anything else. If possible, store the LCM in the packaging situation when it was delivered.

12.7 Safety

- For the crash damaged or unnecessary LCM, it is recommended to wash off liquid crystal by either of solvents such as acetone and ethanol and should be burned up later.
- In the case of LCM is broken, watch out whether liquid crystal leaks out or not. If your hands touch the liquid crystal, wash your hands cleanly with water and soap as soon as possible.
- If you should swallow the liquid crystal, first, wash your mouth thoroughly with water, then drink a lot of water and induce vomiting, and then, consult a physician.
- If the liquid crystal get in your eyes, flush your eyes with running water for at least fifteen minutes.
- If the liquid crystal touches your skin or clothes, remove it and wash the affected part of your skin or clothes with soap and running water.

13.0 Applicable Scope

- This product specification only applies to the products manufactured and sold by our company.
- Any specification, quality etc. about other parts mentioned in this product spec are no concern of our company.