

DM-TFTR247-451
2.47" IPS 480x480 OCTAGONAL
SHAPE ROUND DISPLAY WITH -
MIPI

Contents

- 1 Revision History
- 2 Main Features
- 3 Pin Description
 - 3.1 Panel Pin Description
- 4 Mechanical Drawing
 - 4.1 Panel Mechanical Drawing
- 5 Optics & Electrical Characteristics
 - 5.1 Optical Characteristics
 - 5.2 Absolute Maximum Ratings
 - 5.3 Electrical Characteristics
- 6 Data IC PAD&FPC Pin Assignment
 - 6.1 Data IC PAD (One D-IC)
 - 6.2 FPC Pin Assignments FPC PIN PAD (unit: mm)
- 7 Reliability
- 8 Warranty and Conditions

1 Revision History

Date	Changes
2022-06-20	First release

2 Main Features

Item	Specification	Unit
Screen Size	2.47	inch
Driver Mode	Normally Black, Transmissive mode	-
Display Colors	16.7 M	colors
Resolution	480 × 480	dots
Controller IC	HX8367C	-
Interface	MIPI	-
View Direction	U/D/L/R free viewing direction	-
Panel size	66.64(H) X 70.14(V)	mm
Active area	62.64 × 62.64(circle)	mm
Weight	25	g

3 Pin Description

3.1 Panel Pin Description

1	GND	51	GP00	101	VSN	151	C21N
2	NULL	52	EXT VSPN	102	VSN	152	C22P
3	VCOM	53	TE L	103	VDD3	153	C22N
4	VCOM	54	VSEL	104	VDD3	154	C23P
5	VSSA	55	SD0	105	VSSD	155	C23P
6	VSSA	56	SDA	106	VSSD	156	C23N
7	VCOM	57	DCX	107	VDDD	157	C23N
8	VCOM	58	SCL	108	VDDD	158	C24P
9	OTP PWR	59	OSC	109	HS VSS	159	C24P
10	VGL	60	CSX	110	HS D1 P	160	C24N
11	VGLO	61	RESX	111	HS D1 N	161	C24N
12	VGL REG	62	VSSD	112	HS VSS	162	VDD3 P
13	VGH REG	63	VDD1	113	HS CLK P	163	VDD3 P
14	VCL	64	D23	114	HS CLK N	164	VCL
15	VREF	65	D22	115	HS VSS	165	VCL
16	VSSAC	66	D21	116	HS D0 P	166	VSSA
17	VSSAC	67	D20	117	HS D0 N	167	VSSD P
18	VDD2	68	D19	118	HS VSS	168	C31P
19	VDD3	69	D18	119	HS LD0L	169	C31N
20	VSSA	70	D17	120	HS LD0	170	C32P
21	VSSA	71	D16	121	HS VCC	171	C32N
22	VDD3	72	D15	122	VDD3	172	VDDD
23	DUMMY	73	D14	123	TE R	173	VSSD
24	VTESTOUTN	74	D13	124	VSSA	174	C41P
25	VTESTOUTP	75	D12	125	VTESTOUT	175	C41P
26	VSNR	76	D11	126	VGH REG	176	C41N
27	VSPR	77	D10	127	VCSW2	177	C41N
28	VSSD	78	D9	128	CSP	178	VGH
29	VDDD	79	D8	129	VCSW1	179	VGHO
30	VDD3	80	D7	130	CSN	180	VGH REG
31	VCL	81	D6	131	VDD3 P	181	C51P
32	VSSA	82	D5	132	VDD3 P	182	C51P
33	VSSA	83	D4	133	VSSD P	183	C51N
34	VDD1	84	D3	134	VSSD P	184	C51N
35	LANSEL	85	D2	135	C11P	185	VGL REG
36	DSWAP	86	D1	136	C11N	186	VGLO
37	PSWAP	87	D0	137	C12P	187	VGL
38	VSSD	88	DE	138	C12N	188	VCOM
39	DSTB SEL	89	PCLK	139	C13P	189	VCOM
40	NBWSEL	90	HS	140	C13N	190	VSSA
41	VDD1	91	VS	141	C14P	191	VSSA
42	RGBBP	92	CABC PWM OUT	142	C14P	192	VCOM
43	I2C SA0	93	CABC LED EN	143	C14N	193	VCOM
44	IM3	94	ERR	144	C14N	194	GND
45	IM2	95	VDD1	145	VSP	195	NULL
46	IM1	96	VSSD	146	VSP	196	DUMMY
47	IM0	97	VSP	147	VSSD P		
48	TE R	98	VSP	148	VSN		
49	GP02	99	VSSA	149	VSN		
50	GP01	100	VSSA	150	C21P		

4 Mechanical Drawing

4.1 Panel Mechanical Drawing

Figure 4. Outline Dimension (unit : mm)

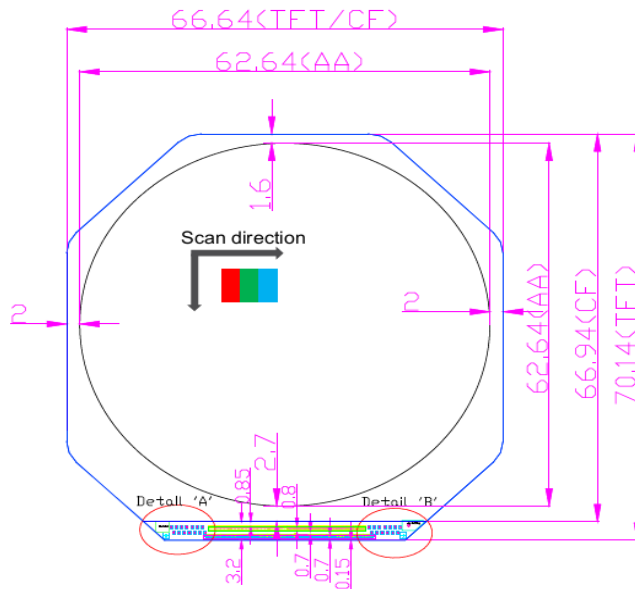
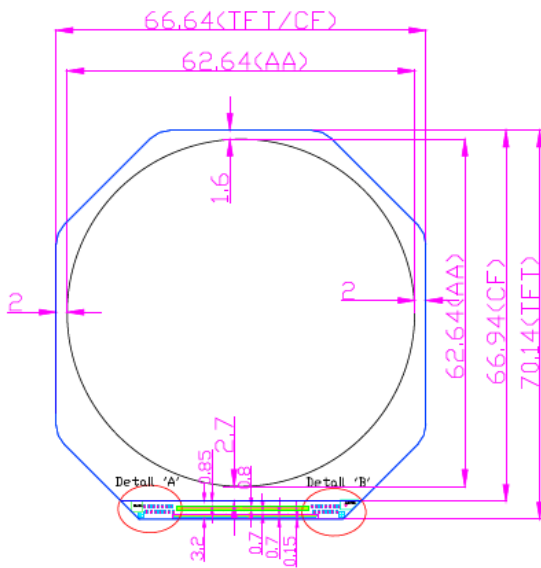
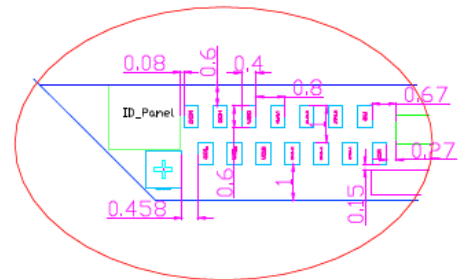

Figure 5. TFT-LCD Panel TEST (unit : mm)



Detail 'A' X 5



Detail 'B' X 5

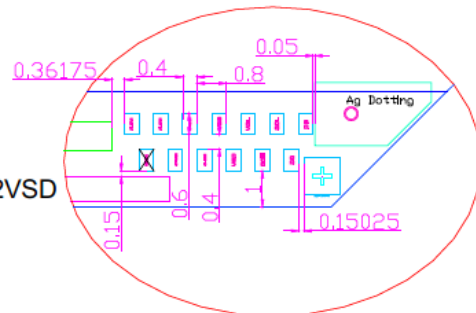

Test Pad

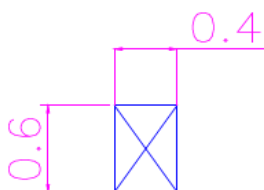

8phase GOA : 8CLK , 4STV ,
 2GCH , 2GCL , 2VGL , 2VDS , 2VSD
 3D : DR/DG/DB
 1C : COM
 1S : SW
 Total : 27 Pads

Unit : mm

Figure 6. Ag Dotting diagram (unit: mm if unspecified)

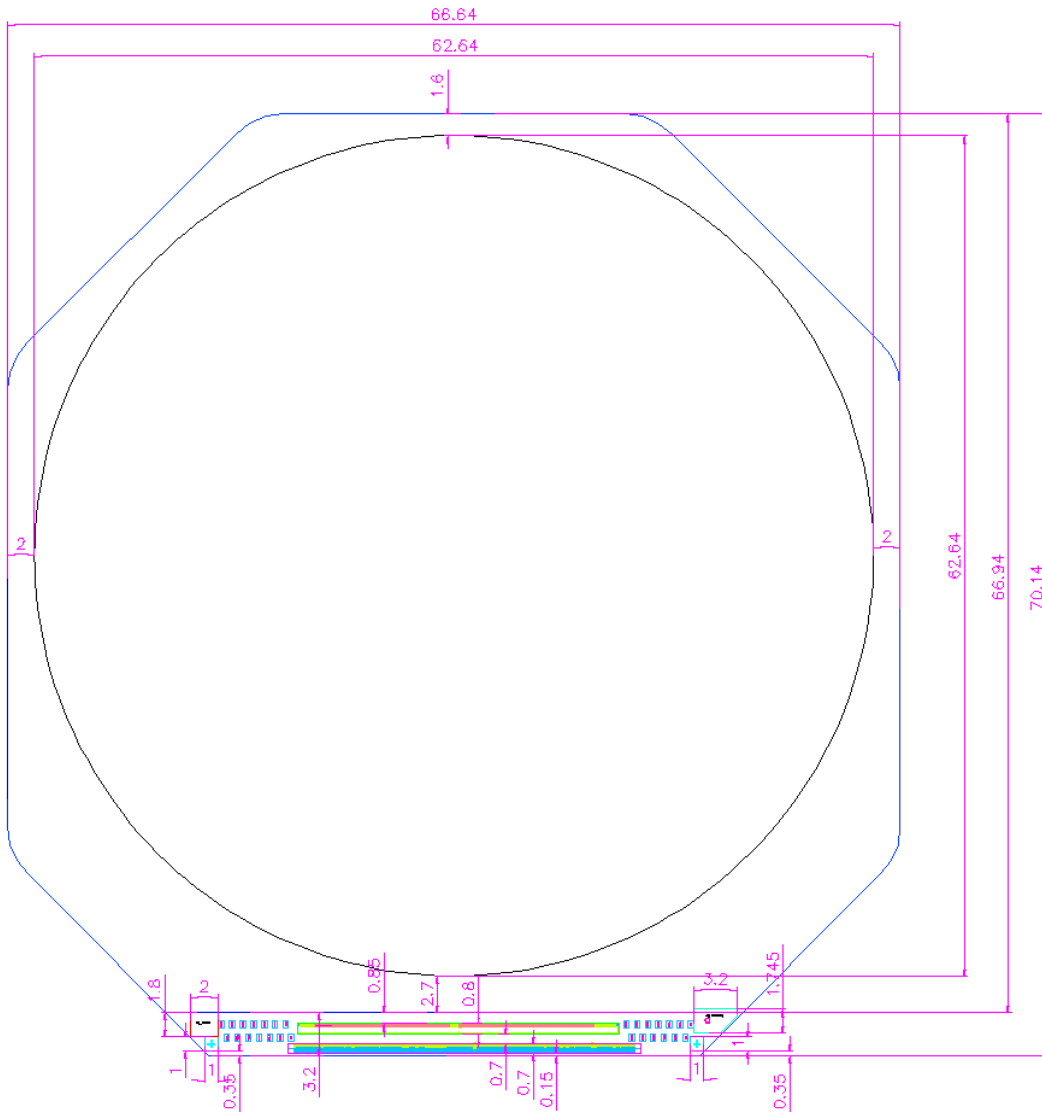

5 Optics & Electrical Characteristics

5.1 Optical Characteristics

Item	Symbol	Condition	Min	Typ	Max	Unit	Remark
View Angles Top	⊖ 3	CR>10	70	85	-	°	Note 1
View Angles Bottom	⊖ 9		70	85	-	°	
View Angles Left	⊖ 12		70	85	-	°	
View Angles Right	⊖ 6		70	85	-	°	
Response Time	Tr + Tf	⊖ = 0°	-	-	35	ms	Note 5
Contrast Ratio	CR	⊖ = 0°	800	1000	-		Note 2
Transmittance	T(%)	⊖ = 0°	3.6	3.9			Note 3*with pol
NTSC	%	⊖ = 0°	65	70			
White	Wx	⊖ = 0°					
	Wy						
Reproduction Of color		Rx	⊖ = 0°	0.626	0.656	0.686	Note 4 CF
		Ry		0.284	0.314	0.344	
	Green	Gx		0.255	0.285	0.315	
		Gy		0.562	0.592	0.622	
	Blue	Bx		0.113	0.143	0.173	
		By		0.059	0.089	0.119	

Note:

- Viewing angle is the angle at which the contrast ratio is greater than 10. The viewing are determined for the horizontal or 3, 9 o' clock direction and the vertical or 6, 12 o' clock direction with respect to the optical axis which is normal to the LCD surface (see FIG.1).
- Contrast measurements shall be made at viewing angle of $\ominus = 0$ and at the center of the LCD surface. Luminance shall be measured with all pixels in the view field set first to white, then to the dark (black) state. (See FIG. 1) Luminance Contrast Ratio (CR) is defined mathematically.

$$CR = \frac{\text{Luminance when displaying a white raster}}{\text{Luminance when displaying a black raster}}$$

- Transmittance is the value without APF Polarizer.
- The color chromaticity coordinates specified in Table1 shall be calculated from The spectral data measured with all pixels first in red, green, blue and white. Measurements shall be made at the center of the C/F. Measurement condition is C - light source & Halogen Lamp
- The electro-optical response time measurements shall be made as FIG.2 by switching the “data” input signal ON and OFF. The times needed for the luminance to change from 10% to 90% is Tr, and 90% to 10% is Tf.

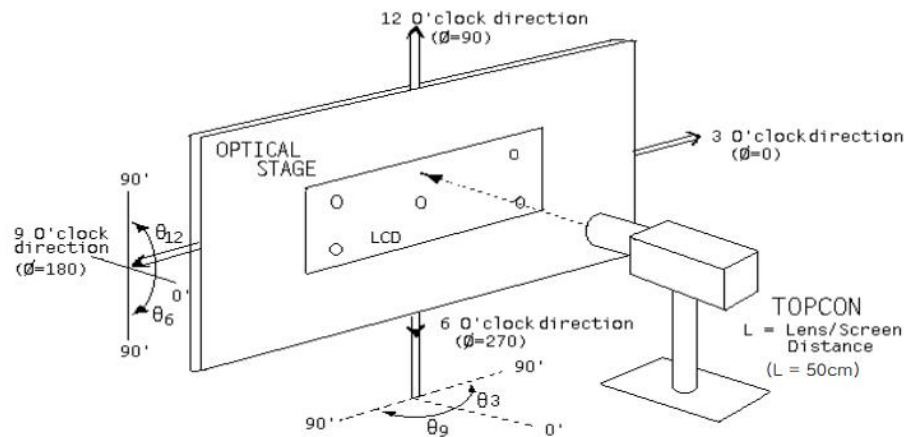
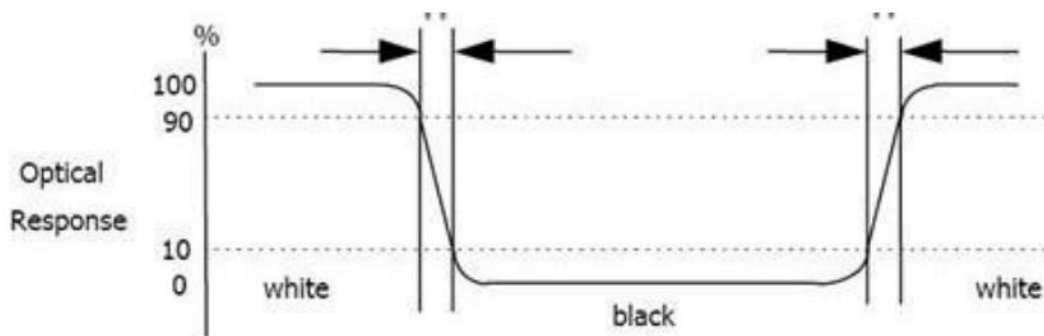
Figure1. M

Figure2. R

5.2 Absolute Maximum Ratings

The followings are maximum values which, if exceed, may cause faulty operation or damage to the unit. Make sure all the design characteristics are adequate before the panel is initialed. All the measurements should be operated with driver IC and FPC mounted.

Parameter	Symbol	Min	Max	Unit	Remark
Operating Ambient Humidity *1)	Hop	10	*2)	%RH	*2)
Storage Humidity	Hst	10	*2)	%RH	*2)
Operating Temperature	T _{OP}	-10	60	°C	
Storage Temperature	T _{ST}	-30	70	°C	

[VSS = GND = 0V]

Note:

*1) Temp ≤ 60°C 90% RH MAX

*2) Non-condensation

5.3 Electrical Characteristics

Recommend Parameters for Electrical Characteristics

Parameter	Symbol	Value	Unit	Remark
		Reference		
TFT Gate ON Voltage	VGH	15	V	Note1
TFT Gate OFF Voltage	VGL	-11	V	Note2
TFT Common Electrode Voltage	VCOM	-1	V	Note3

Note::

1. VGH is TFT Gate operating voltage.
2. VGL is TFT Gate operating voltage. The low voltage level of VGL signal must be fluctuate with same phase as Vcom, the storage capacitance structure of the product is storage on common.
3. Vcom must be adjusted to optimize display quality, as Crosstalk and Contrast Ratio etc., We just kindly recommend the setting-voltages the reference value.

In order to get the optimized display quality, the setting-voltage should be changed according to customer' s developing condition. (The display quality could be changed by customer' s setting - voltage.)

6 Data IC PAD&FPC Pin Assignment

6.1 Data IC PAD (One D-IC)

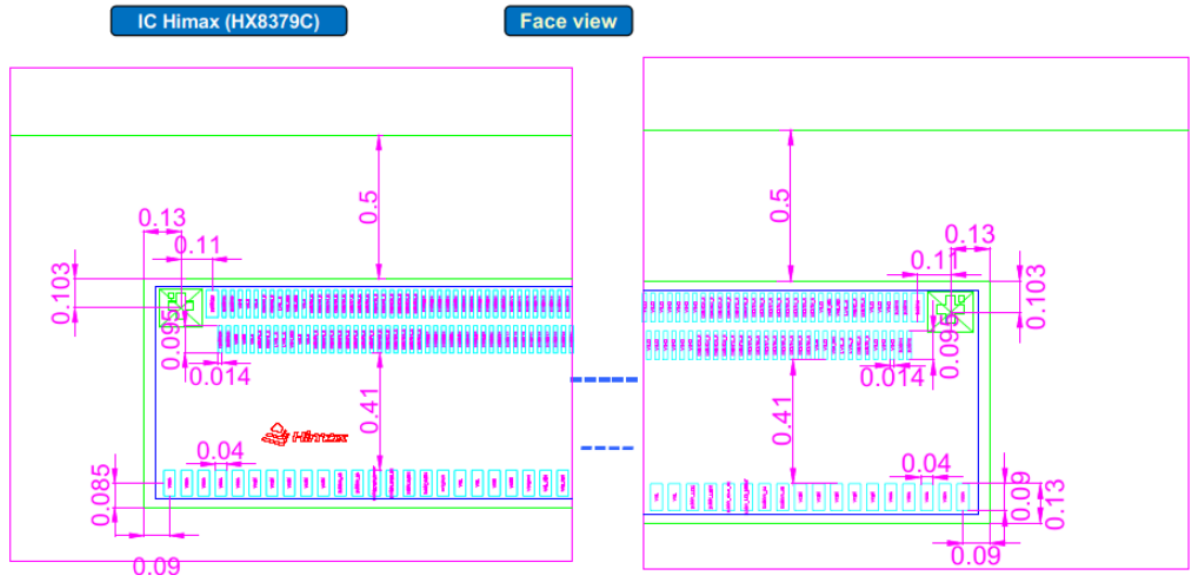

6.2 FPC Pin Assignments FPC PIN PAD (unit: mm)

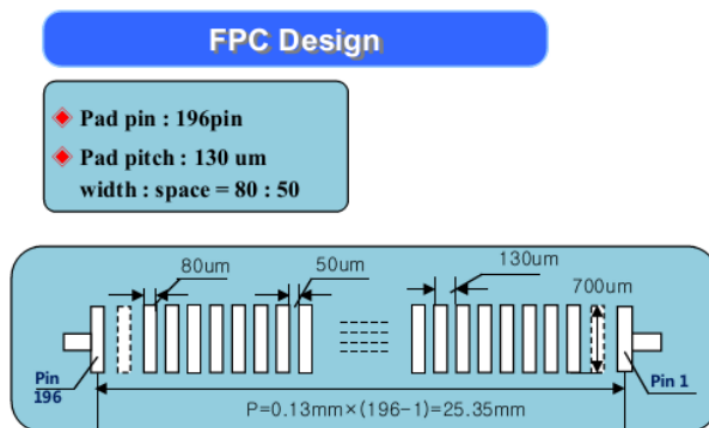

Main signals Resistance Design data

Data Sig.	Target (Ω)	Design (Ω)
VSSA	5	0.5
VGH	10	0.9
VSSD	5	1.62
VGL	10	0.8
VCL	10	0.51

7 Reliability

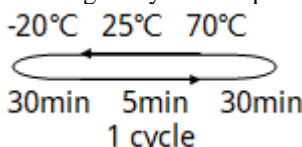
Test Item	Content of Test	Test Condition	Note
High Temperature Storage	Endurance test applying the high storage temperature for a long time.	80°C 200hrs	2
Low Temperature Storage	Endurance test applying the high storage temperature for a long time.	-30°C 200hrs	1,2
High Temperature Operation	Endurance test applying the electric stress (Voltage & Current) and the thermal stress to the element for a long time.	70°C 200hrs	-
Low Temperature Operation	Endurance test applying the electric stress under low temperature for a long time.	-20 °C 200hrs	1
High Temperature/ Humidity Operation	The module should be allowed to stand at 60°C,90%RH max, for 96hrs under no-load condition excluding the polarizer. Then taking it out and drying it at normal temperature.	60°C,90%RH 96hrs	1,2
Thermal Shock Resistance	The sample should be allowed stand the following 10 cycles of operation 	-20°C/70°C 10 cycles	-

Note1: No dew condensation to be observed.

Note2: The function test shall be conducted after 4 hours storage at the normal. Temperature and humidity after remove from the rest chamber.

8 Warranty and Conditions

<http://www.displaymodule.com/pages/faq> HYPERLINK

"http://www.displaymodule.com/pages/faq"