

**DM-TFTR108-458**

1.08" 240 X 210 65K IPS Transmissive TFT - SPI

## Table of Contents

1	General Description .....	4
2	Module Parameter .....	4
3	Mechanical Drawings .....	5
4	Module Interface .....	6
5	Application Circuit.....	7
6	Absolute Maximum Ratings .....	8
7	Electrical Specification .....	8
8	AC Characteristics .....	8
9	Command Table .....	8
10	Recommended Setting and Initialization Flow for Reference .....	8
11	Optical Specifications .....	9
11.1	Optical Specifications .....	9
11.2	Definition of Response Time .....	10
11.3	Definition of Contrast Ratio.....	10
11.4	Definition of Viewing Angles.....	11
11.5	Definition of Color Appearance.....	11
11.6	Definition of Surface Luminance, Uniformity and Transmittance .....	11
12	Quality Assurance .....	12
12.1	Purpose.....	12
12.2	Agreement Items .....	12
12.3	Standard of the Product Visual Inspection.....	12
12.4	Inspection Specification.....	13
12.5	Classification of Defects .....	17
12.6	Identification/marketing criteria .....	17
12.7	Packing.....	17
13	Reliability Specification.....	18
14	Precautions and Warranty .....	19
14.1	Safety .....	19
14.2	Handling.....	19
14.3	Operation.....	19
14.4	Static Electricity .....	19
14.5	Limited Warranty .....	19
15	Packaging.....	20
16	Prior Consult Matter.....	20

## 1 General Description

This display module is a transmissive type color active matrix TFT(Thin Film Transistor) liquid crystal display (LCD) that uses amorphous silicon TFT as a switching device. This module is composed of a TFT LCD module, a driver circuit, and a back-light unit. The resolution of a 1.08" contains 240(RGB)X210 dots and can display up to 65k colors.

## 2 Module Parameter

Features	Details	Unit
Display Size(Diagonal)	1.08	inch
LCD type	$\alpha$ -Si TFT	-
Display Mode	IPS / Transmissive / Normally Black	-
Resolution	240RGB x 210	-
View Direction	All	Best image
Module Outline	31.28(H) × 30.3(V) × 1.45(T) (Note 1)	mm
TP Outline	N/A	mm
TP Viewing Area	N/A	mm
TP Active Area	N/A	mm
Active Area	27.58 (H) × 24.13(V)	mm
Viewing Area	ALL	mm
Display Colors	65K	-
Interface	4-SPI	-
Driver IC	ST7789V2	-
Operating Temperature	-20 ~ 60	°C
Storage Temperature	-30 ~ 70	°C
Weight	TBD	g

Note 1: Excluding hooks, posts, FPC/FPC tail etc.

### 3 Mechanical Drawings

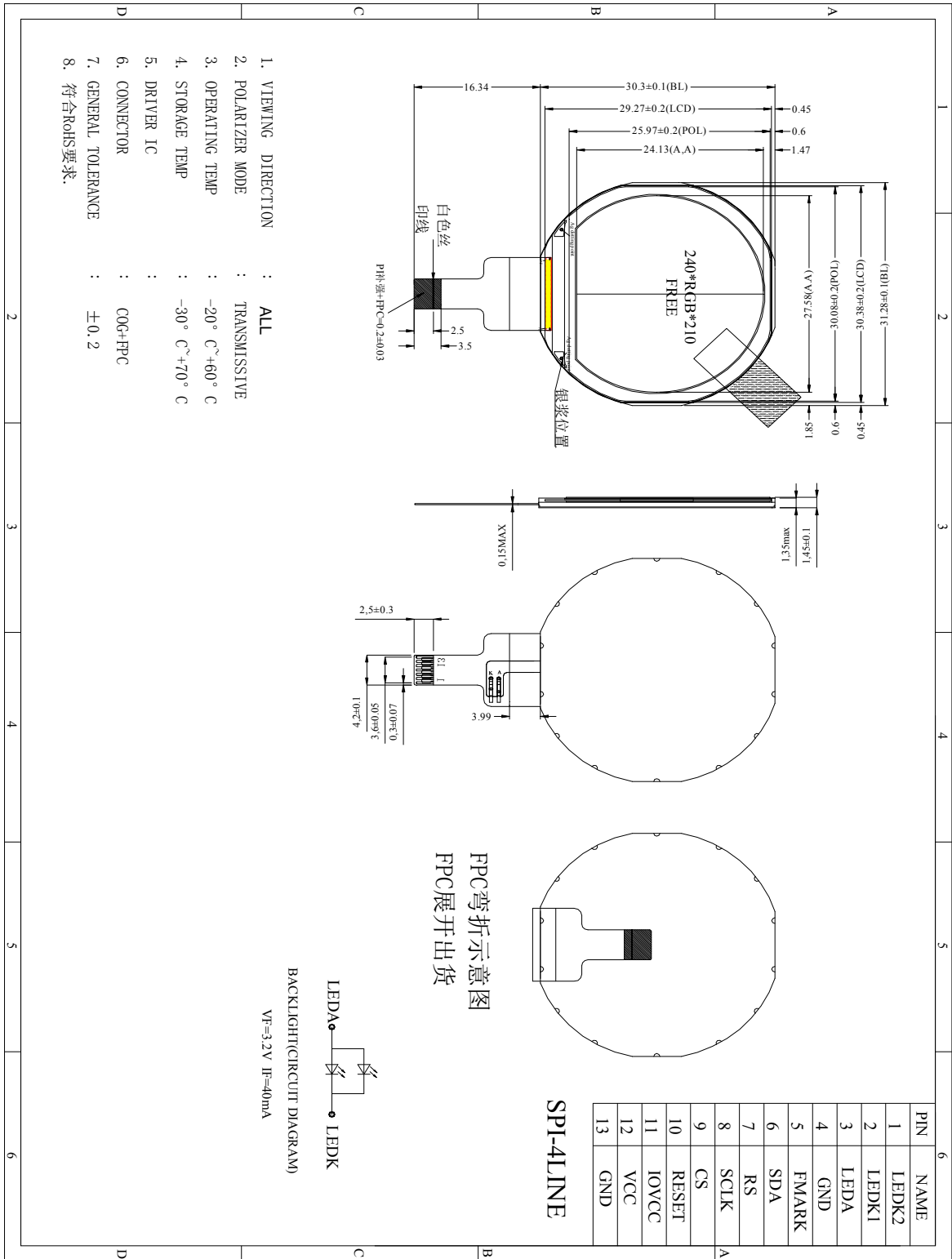

## 4 Module Interface

NO	SYMBOL	FUNCTION
1	LEDK2	LED Cathode
2	LEDK1	LED Cathode
3	LEDA	LED Anode
4	GND	Power Ground
5	FMARK	Tearing effect signal is used to synchronize MCU to frame memory writing.
6	SDA	SPI interface input/output pin. The data is latched on the rising edge of the SCL signal.
7	RS	Display data/command selection pin in 4-line serial interface.
8	SCLK	This pin is used to be serial interface clock.
9	CS	Chip selection pin; Low enable, High disable.
10	RESET	This signal will reset the device and it must be applied to properly initialize the chip. Signal is active low.
11	IOVCC	Power Supply for I/O system. IOVCC=1.65V~3.3V
12	VCC	Power Supply for Analog, VCC=2.5V~3.3V.
13	GND	Power Ground

## 5 Application Circuit

### Backlight recommended circuit

Motherboard driver backlight is need constant current circuit, if the rated voltage screen after light brightness difference.Current and power consumption of the machine are inconsistent, so recommend a backlight driving circuit is best rated current.It is recommended to use IC (AW9364). The reference circuit is as follows:

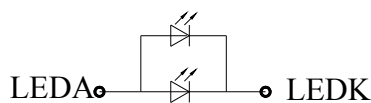
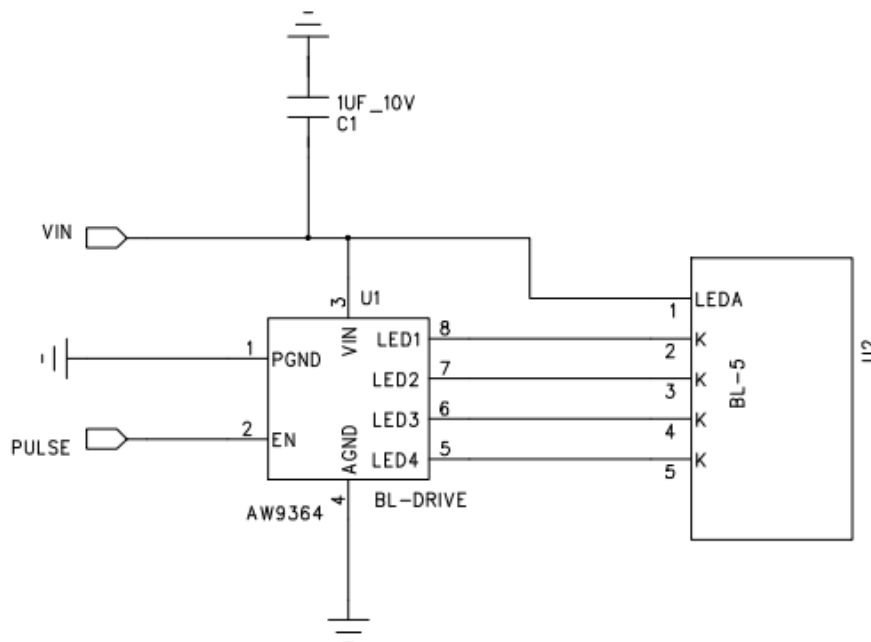

BACKLIGHT(CIRCUIT DIAGRAM)

VF=3.2V IF=40mA

Note: constant current circuit for every LED, and though LED lamp current is less than 40mA. Recommend between 15mA and 20 mA for every LED.

## 6 Absolute Maximum Ratings

VSS=0V, Ta=25°C

Item		Symbol	Min.	Max.	Unit
Supply Voltage	Power supply	VDD	-0.3	+4.6	V
	Analog	-	-	-	V
	IO	IOVDD	-0.3	+4.6	V
Input Voltage		V <sub>i</sub>	-0.3	IOVDD+0.3	V
Storage temperature		T <sub>stg</sub>	-30	+80	°C
Operating temperature		T <sub>op</sub>	-20	+70	°C
Storage humidity		H <sub>stg</sub>	10	Note 1	%RH
Operating humidity		H <sub>op</sub>	10	Note 1	%RH

Note 1: 90%RH max, If Ta is below 50°C; 60%RH max, If Ta is over 60°C.

## 7 Electrical Specification

DC Characteristics

Item		Symbol	Min.	Typ.	Max.	Unit
Supply Voltage	Power supply	VDD	2.4	2.8	3.3	V
	Analog	VCI	2.4	2.8	3.3	V
	IO	IOVDD	1.65	1.8/2.8	3.3	V
Logic Low input voltage		V <sub>IL</sub>	-0.3IOVDD	-	0.3IOVDD	V
Logic High input voltage		V <sub>IH</sub>	0.7IOVDD	-	IOVDD	V
Logic Low output voltage		V <sub>OL</sub>	-	-	0.2IOVDD	V
Logic High output voltage		V <sub>OH</sub>	0.8IOVDD	-	-	V
Current Consumption	Normal display	I <sub>vdd</sub>	-	31	-	mA
	Standby mode	I <sub>vdd</sub>	-	30	-	uA
Frame Frequency		f <sub>FR</sub>	-	60	-	Hz

## 8 AC Characteristics

Reset timing and interface timing:

Please refer to IC datasheet.

## 9 Command Table

Please refer to IC datasheet.

## 10 Recommended Setting and Initialization Flow for Reference

Please refer to attached file.

## 11 Optical Specifications

### 11.1 Optical Specifications

Ta=25°C, VDD=2.8V, TN LC+ Polarizer

	Item		Symbol	Condition	Specification			Unit
					Min.	Typ.	Max.	
Backlight On (Transmissive Mode)	Luminance on surface( $I_f=32\text{mA}$ )		$L_v$	Normally viewing angle $\theta_x = \theta_y = 0^\circ$		400	-	cd/m <sup>2</sup>
	Contrast ratio		$CR$		-	600	-	-
	Response time		$T_R$		-	10	20	ms
			$T_F$	-	-	20	30	
	Chromaticity Transmissive	Red	$X_R$	-	0.614	0.644	0.674	-
			$Y_R$		0.290	0.320	0.350	-
		Green	$X_G$		0.270	0.300	0.330	-
			$Y_G$		0.540	0.570	0.600	-
		Blue	$X_B$		0.104	0.134	0.164	-
			$Y_B$		0.097	0.127	0.157	-
	White	$X_W$	0.267	0.297	0.327	-		
		$Y_W$	0.302	0.332	0.362	-		
	Viewing Angle	Horizontal	$\theta_{x+}$	Center $CR \geq 10$	-	80	-	Deg.
			$\theta_{x-}$		-	80	-	
		Vertical	$\theta_{y+}$		-	80	-	
			$\theta_{y-}$		-	80	-	
NTSC Ratio(Gamut)		-	-	-	60	-	%	



## 11.2 Definition of Response Time

### 11.2.1 Normally Black Type (Negative)

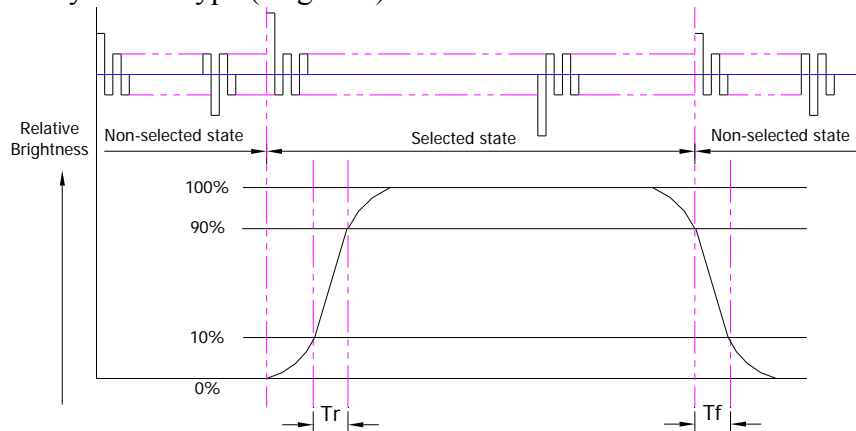

Tr is the time it takes to change from non-selected state with relative luminance 10% to selected state with relative luminance 90%;

Tf is the time it takes to change from selected state with relative luminance 90% to non-selected state with relative luminance 10%.

### 11.2.2 Normally White Type (Positive)

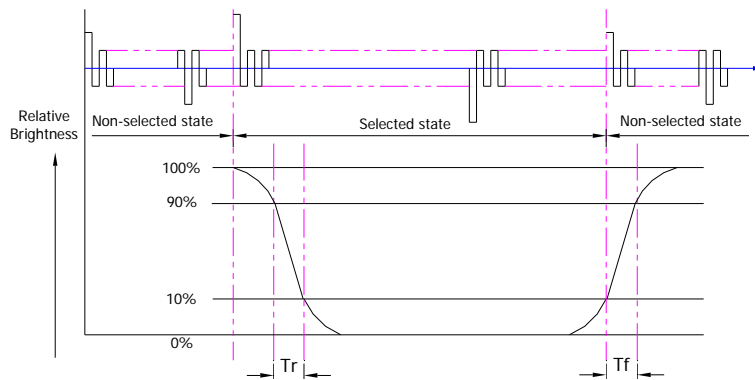

Tr is the time it takes to change from non-selected state with relative luminance 90% to selected state with relative luminance 10%;

Tf is the time it takes to change from selected state with relative luminance 10% to non-selected state with relative luminance 90%;

## 11.3 Definition of Contrast Ratio

Contrast is measured perpendicular to display surface in reflective and transmissive mode. The measurement condition is:

Measuring Equipment	BM-7 or EQUI
Measuring Point Diameter	3mm//1mm
Measuring Point Location	Active Area centre point
Test pattern	A: All Pixels white
	B: All Pixel black
Contrast setting	Maximum

Definitions: CR (Contrast) = Luminance of White Pixel / Luminance of Black Pixel

**11.4 Definition of Viewing Angles**

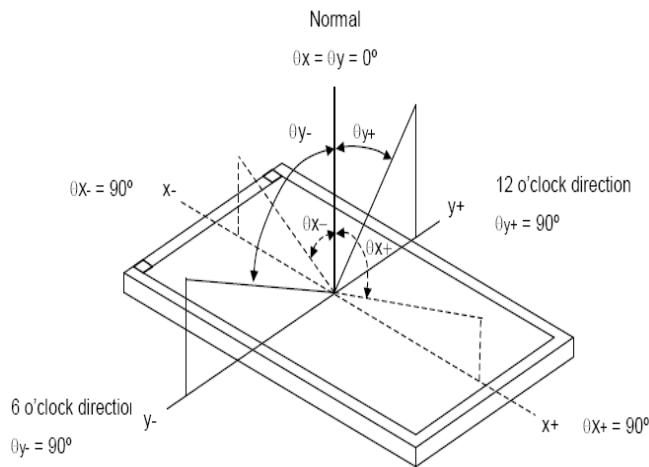

Measuring machine: LCD-5100 or EQUI

**11.5 Definition of Color Appearance**

R,G,B and W are defined by (x, y) on the IE chromaticity diagram

NTSC=area of RGB triangle/area of NTSC triangleX100%

Measuring picture: Red, Green, Blue and White (Measuring machine: BM-7)

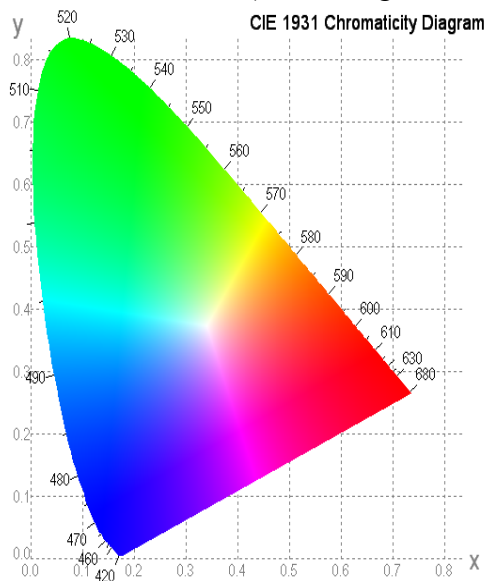

**11.6 Definition of Surface Luminance, Uniformity and Transmittance**

Using the transmissive mode measurement approach, measure the white screen luminance of the display panel and backlight.

11.6.1 Surface Luminance: LV = average (LP1:LP5)

11.6.2 Uniformity = Minimal (LP1:LP5) / Maximal (LP1:LP5) \* 100%

11.6.3 Transmittance = LV on LCD / LV on Backlight \* 100%

Note :Measuring machine:BM-7

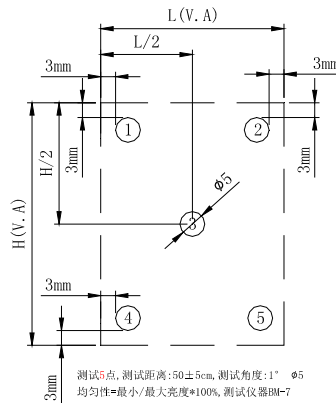

## 12 Quality Assurance

### 12.1 Purpose

This standard for Quality Assurance assures the quality of LCD module products supplied to customer by TSD display.

### 12.2 Agreement Items

TSD and customer shall negotiate if the following situation occurs:

12.2.1 Discrepancies between TSD's QA standards and customer's QA standards.

12.2.2 Additional requirement to be added in product specification.

12.2.3 Any other special problem.

### 12.3 Standard of the Product Visual Inspection

12.3.1 Appearance inspection:

12.3.1.1 The inspection must be under illumination about 1000 – 1500 lx, and the distance of view must be at 30cm ± 2cm.

12.3.1.2 The viewing angle should be 45° from the vertical line without reflection light or follows customer's viewing angle specifications.

12.3.1.3 Definition of area: A Zone: Active Area, B Zone: Viewing Area.

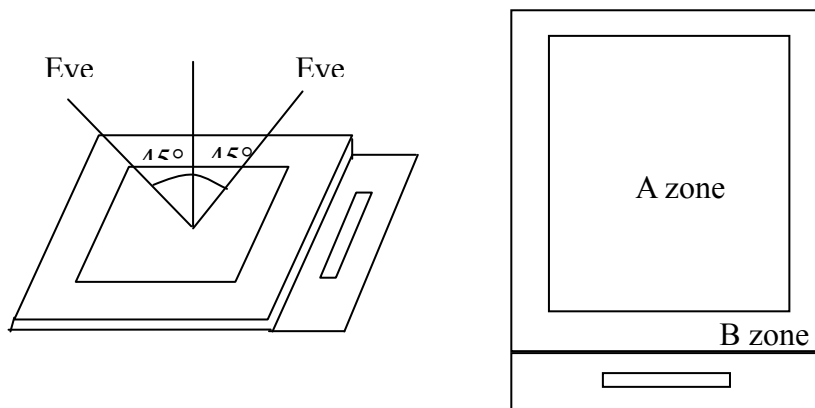

12.3.2 Basic principle: A set of sample to indicate the limit of acceptable quality level must be discussed by both TSD and customer when there is any dispute happened.

**12.4 Inspection Specification**

Sampling plan according to GB/T2828.1-2012/ISO 2859-1: 1999 and ANSI/ASQC

Z1.4-1993, normal level 2 and based on:

Major defect: AQL 0.4

Minor defect: AQL 1.0

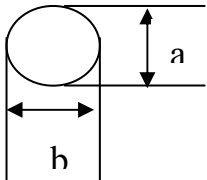
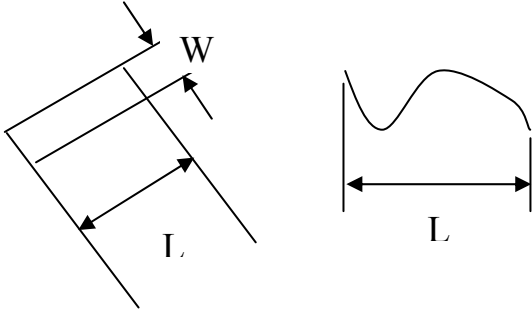
No.	Item	Criteria (Unit: mm)															
01	Black / White spot Foreign material (Round type) Pinholes Stain Particles inside cell. (Minor defect)	 <div style="display: flex; justify-content: space-around; align-items: center;"> <table border="1" data-bbox="932 808 1433 1249"> <thead> <tr> <th>Size \ Area</th> <th>Acc. Qty</th> </tr> </thead> <tbody> <tr> <td><math>\varphi \leq 0.10</math></td> <td>Ignore</td> </tr> <tr> <td><math>0.10 &lt; \varphi \leq 0.15</math></td> <td>2</td> </tr> <tr> <td><math>0.15 &lt; \varphi \leq 0.20</math></td> <td>1</td> </tr> <tr> <td><math>0.20 &lt; \varphi</math></td> <td>0</td> </tr> <tr> <td>Total</td> <td>2 (no include <math>\varphi \leq 0.10</math>)</td> </tr> </tbody> </table> </div> <p><math>\varphi = (a + b) / 2</math></p> <p>Distance between 2 defects should more than 5mm apart.</p>	Size \ Area	Acc. Qty	$\varphi \leq 0.10$	Ignore	$0.10 < \varphi \leq 0.15$	2	$0.15 < \varphi \leq 0.20$	1	$0.20 < \varphi$	0	Total	2 (no include $\varphi \leq 0.10$ )			
Size \ Area	Acc. Qty																
$\varphi \leq 0.10$	Ignore																
$0.10 < \varphi \leq 0.15$	2																
$0.15 < \varphi \leq 0.20$	1																
$0.20 < \varphi$	0																
Total	2 (no include $\varphi \leq 0.10$ )																
02	Black and White line Scratch Foreign material (Line type) (Minor defect)	 <table border="1" data-bbox="644 1686 1270 1973"> <thead> <tr> <th>Length</th> <th>Width</th> <th>Acc. Qty</th> </tr> </thead> <tbody> <tr> <td>/</td> <td><math>W \leq 0.03</math></td> <td>Ignore</td> </tr> <tr> <td><math>L \leq 2</math></td> <td><math>0.03 &lt; W \leq 0.05</math></td> <td>1</td> </tr> <tr> <td>/</td> <td><math>0.05 &lt; W</math></td> <td>0</td> </tr> <tr> <td colspan="2">Total</td> <td>1</td> </tr> </tbody> </table>	Length	Width	Acc. Qty	/	$W \leq 0.03$	Ignore	$L \leq 2$	$0.03 < W \leq 0.05$	1	/	$0.05 < W$	0	Total		1
Length	Width	Acc. Qty															
/	$W \leq 0.03$	Ignore															
$L \leq 2$	$0.03 < W \leq 0.05$	1															
/	$0.05 < W$	0															
Total		1															

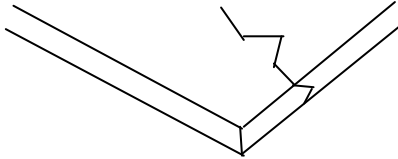
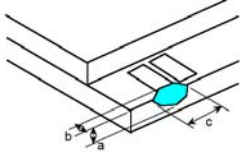
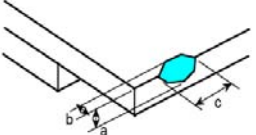
No.	Item	Criteria (Unit: mm)										
		Distance between 2 defects should more than 5mm apart. Scratches not viewable through the back of the display are acceptable.										
03	Glass Crack (Minor defect)	 <p>LCD with extensible crack line is unacceptable(When press the cracked LCD area, the line will expand, we define it is extensible crack line)</p>										
04	Glass Chipping Pad Area: (Minor defect)	 <table border="1" data-bbox="772 1032 1241 1128"> <thead> <tr> <th>Length and Width</th> <th>Acc. Qty</th> </tr> </thead> <tbody> <tr> <td><math>c &lt; 5.0, b &lt; 0.4</math></td> <td>Ignore</td> </tr> </tbody> </table>	Length and Width	Acc. Qty	$c < 5.0, b < 0.4$	Ignore						
Length and Width	Acc. Qty											
$c < 5.0, b < 0.4$	Ignore											
05	Glass Chipping Rear of Pad Area: (Minor defect)	 <table border="1" data-bbox="772 1279 1241 1525"> <thead> <tr> <th>Length and Width</th> <th>Acc. Qty</th> </tr> </thead> <tbody> <tr> <td><math>c &gt; 3.0, b &lt; 1.0</math></td> <td>1</td> </tr> <tr> <td><math>c &lt; 3.0, b &lt; 1.0</math></td> <td>2</td> </tr> <tr> <td><math>c &lt; 3.0, b &lt; 0.5</math></td> <td>4</td> </tr> <tr> <td colspan="2"><math>a &lt; \text{Glass Thickness}</math></td> </tr> </tbody> </table>	Length and Width	Acc. Qty	$c > 3.0, b < 1.0$	1	$c < 3.0, b < 1.0$	2	$c < 3.0, b < 0.5$	4	$a < \text{Glass Thickness}$	
Length and Width	Acc. Qty											
$c > 3.0, b < 1.0$	1											
$c < 3.0, b < 1.0$	2											
$c < 3.0, b < 0.5$	4											
$a < \text{Glass Thickness}$												

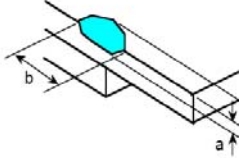
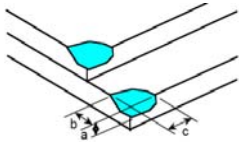
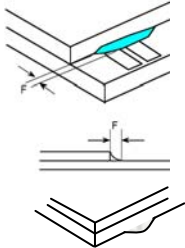
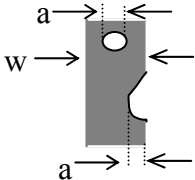
No.	Item	Criteria (Unit: mm)								
06	Glass Chipping Except Pad Area: (Minor defect) 	<table border="1" data-bbox="772 434 1243 584"> <thead> <tr> <th>Length and Width</th> <th>Acc. Qty</th> </tr> </thead> <tbody> <tr> <td><math>c \leq 0.6, b &lt; 5.0</math></td> <td>Ignore</td> </tr> <tr> <td colspan="2"><math>a &lt; \text{Glass Thickness}</math></td> </tr> </tbody> </table>	Length and Width	Acc. Qty	$c \leq 0.6, b < 5.0$	Ignore	$a < \text{Glass Thickness}$			
Length and Width	Acc. Qty									
$c \leq 0.6, b < 5.0$	Ignore									
$a < \text{Glass Thickness}$										
07	Glass Corner Chipping: (Minor defect) 	<table border="1" data-bbox="772 831 1243 1025"> <thead> <tr> <th>Length and Width</th> <th>Acc. Qty</th> </tr> </thead> <tbody> <tr> <td><math>c &lt; 2.0, b &lt; 1.5</math></td> <td>Ignore</td> </tr> <tr> <td><math>c &lt; 1.5, b &lt; 2</math></td> <td>Ignore</td> </tr> <tr> <td colspan="2"><math>a &lt; \text{Glass Thickness}</math></td> </tr> </tbody> </table>	Length and Width	Acc. Qty	$c < 2.0, b < 1.5$	Ignore	$c < 1.5, b < 2$	Ignore	$a < \text{Glass Thickness}$	
Length and Width	Acc. Qty									
$c < 2.0, b < 1.5$	Ignore									
$c < 1.5, b < 2$	Ignore									
$a < \text{Glass Thickness}$										
08	Glass Burr: (Minor defect) 	<p data-bbox="584 1211 1310 1245">Glass burr don't affect assemble and module dimension.</p> <table border="1" data-bbox="772 1294 1243 1395"> <thead> <tr> <th>Length</th> <th>Acc. Qty</th> </tr> </thead> <tbody> <tr> <td><math>F &lt; 0.5</math></td> <td>Ignore</td> </tr> </tbody> </table>	Length	Acc. Qty	$F < 0.5$	Ignore				
Length	Acc. Qty									
$F < 0.5$	Ignore									
09	FPC Defect: (Minor defect) 	<p data-bbox="584 1518 986 1552">9.1 Dent, pinhole width <math>a &lt; w/2</math>.</p> <p data-bbox="584 1570 847 1603">(w: circuitry width.)</p> <p data-bbox="584 1621 1007 1655">9.2 Open circuit is unacceptable.</p> <p data-bbox="584 1673 1193 1706">9.3 No oxidation, contamination and distortion.</p>								

No.	Item	Criteria (Unit: mm)										
10	Screen deformation 	Test for insertion of plug gauge at highest warping point: (0.96-3.1inches does not contain3.1) $H \leq 0.25\text{MM}$ The client has special requirements,according to drawing										
11	Bubble on Polarizer (Minor defect)	<table border="1" data-bbox="774 674 1241 920"> <thead> <tr> <th>Diameter</th> <th>Acc. Qty</th> </tr> </thead> <tbody> <tr> <td><math>\varphi \leq 0.15</math></td> <td>Ignore</td> </tr> <tr> <td><math>0.15 &lt; \varphi \leq 0.20</math></td> <td>2</td> </tr> <tr> <td><math>0.20 &lt; \varphi \leq 0.30</math></td> <td>1</td> </tr> <tr> <td><math>0.3 &lt; \varphi</math></td> <td>None</td> </tr> </tbody> </table>	Diameter	Acc. Qty	$\varphi \leq 0.15$	Ignore	$0.15 < \varphi \leq 0.20$	2	$0.20 < \varphi \leq 0.30$	1	$0.3 < \varphi$	None
Diameter	Acc. Qty											
$\varphi \leq 0.15$	Ignore											
$0.15 < \varphi \leq 0.20$	2											
$0.20 < \varphi \leq 0.30$	1											
$0.3 < \varphi$	None											
12	Dent on Polarizer (Minor defect)	<table border="1" data-bbox="774 938 1241 1184"> <thead> <tr> <th>Diameter</th> <th>Acc. Qty</th> </tr> </thead> <tbody> <tr> <td><math>\varphi \leq 0.15</math></td> <td>Ignore</td> </tr> <tr> <td><math>0.15 &lt; \varphi \leq 0.20</math></td> <td>2</td> </tr> <tr> <td><math>0.20 &lt; \varphi \leq 0.30</math></td> <td>1</td> </tr> <tr> <td><math>0.3 &lt; \varphi</math></td> <td>None</td> </tr> </tbody> </table>	Diameter	Acc. Qty	$\varphi \leq 0.15$	Ignore	$0.15 < \varphi \leq 0.20$	2	$0.20 < \varphi \leq 0.30$	1	$0.3 < \varphi$	None
Diameter	Acc. Qty											
$\varphi \leq 0.15$	Ignore											
$0.15 < \varphi \leq 0.20$	2											
$0.20 < \varphi \leq 0.30$	1											
$0.3 < \varphi$	None											
13	Bezel	13.1 No rust, distortion on the Bezel. 13.2 No visible fingerprints, stains or other contamination.										
14	Touch Panel	D: Diameter W: width L: length 14.1 Spot: $D \leq 0.20$ is acceptable $0.20 < D \leq 0.3$ , acceptable QTY, 3 2dots are acceptable and the distance between defects should more than 5mm. $D > 0.3$ is unacceptable 14.2 Dent: $D > 0.30$ is unacceptable 14.3 Scratch: $W \leq 0.03$ , $L \leq 10$ is acceptable, $0.03 < W \leq 0.10$ , $L \leq 10$ ,acceptable QTY, 3 Distance between 2 defects should more than 5 mm. $W > 0.10$ is unacceptable.										

No.	Item	Criteria (Unit: mm)
15	PCB	15.1 No distortion or contamination on PCB terminals. 15.2 All components on PCB must same as documented on the BOM/component layout. 15.3 Follow IPC-A-600F.
16	Soldering	Follow IPC-A-610C standard
17	Electrical Defect (Major defect)	The below defects must be rejected. 17.1 Missing vertical / horizontal segment, 17.2 Abnormal Display. 17.3 No function or no display. 17.4 Current exceeds product specifications. 17.5 LCD viewing angle defect. 17.6 No Backlight. 17.7 Dark Backlight. 17.8 Touch Panel no function. 17.9 Dark Dot –one Allowed. 17.10 Bright Dot – one Allowed. Remark: 1. A pixel defect is acceptable if one color is none functional and causes a bright dot. The display may have one case where one color is out and cause a dark dot. 2. Bright dot caused by scratch and foreign object accords to item1.
18	Leak	Yellow light,OK; White light,According to the limit sample

Remark: Visual and cosmetic defects are rejectable only if these fall within the LCD viewing area.

### 12.5 Classification of Defects

Visual defects (Except no / wrong label) are treated as minor defect and electrical defect is major.

### 12.6 Identification/marketing criteria

Any unit with illegible / wrong /double or no marking/ label shall be rejected.

### 12.7 Packing

12.7.1 There should be no damage of the outside carton box, each packaging box should has label in the correct location per packing drawing requirement.

12.7.2 All direct package materials shall offer ESD protection.



### 13 Reliability Specification

Item	Condition	Cycle Time	Quantity	Remark
Constant Temp. and Constant Humidity Operation Test	+40 ± 3°C, 90 ± 3%RH	96hrs	--	*1
High Temp. Operation Test	+70 ± 3°C	96hrs	--	
Low Temp. Operation Test	-20 ± 3°C	96hrs	--	
Thermal Shock Test	-20 ± 3°C (30min) +70 ± 3°C (30min)	10cycles	--	
ESD Test(end product)	150pF, 330Ω, ±2KV, Contact	10times	--	*2, *3
	150pF, 330Ω, ±6KV, Air			
Vibration Test (for packaging)	Frequency: 10Hz to 55Hz to 10Hz, Swing: 1.5mm, time : X, Y, Z each 2H.	6hrs	One inner carton	*4

Note 1. For humidity test, DI water should be used.

Inspection Standard: Inspect after 1-2hrs storage at room temperature, the sample shall be free from the following defects:

- Air bubble in the LCD
- Seal Leakage
- Non-display
- Missing Segment
- Glass Crack
- IDD is greater than twice initial value.
- Others as per QA Inspection Criteria

Note 2. No defect is allowed after testing

The End Product ESD value is only indicative and depends on customer ESD protection design for the whole system.

Note 3. ESD should be applied to LCD glass panel, not other areas (such as on IC and so on) IDD should be within twice initial value.

In case of malfunction defect caused by ESD damage, if it would be recovered to normal state after resetting, it would be judged as a good part.

Note 4. Only upon request.

## 14 Precautions and Warranty

### 14.1 Safety

14.1.1 The liquid crystal in the LCD is poisonous. Do not put it in your mouth. If the liquid crystal touches your skin or clothes, wash it off immediately using soap and water.

14.1.2 Since the liquid crystal cells are made of glass, do not apply strong impact on them. Handle with care.

### 14.2 Handling

14.2.1 Reverse and use within ratings in order to keep performance and prevent damage.

14.2.2 Do not wipe the polarizer with dry cloth, as it might cause scratch. If the surface of the LCD needs to be cleaned, wipe it swiftly with cotton or other soft cloth soaked with petroleum IPA, do not use other chemicals.

### 14.3 Operation

14.3.1 Do not drive LCD with DC voltage

14.3.2 Response time will increase below lower temperature

14.3.3 Display may change color with different temperature

14.3.4 Mechanical disturbance during operation, such as pressing on the display area, may cause the segments to appear “fractured”.

### 14.4 Static Electricity

14.4.1 CMOS LSIs are equipped in this unit, so care must be taken to avoid the electro-static charge, by ground human body, etc.

14.4.2 The normal static prevention measures should be observed for work clothes and benches.

14.4.3 The module should be kept into anti-static bags or other containers resistant to static for storage.

### 14.5 Limited Warranty

14.5.1 Unless otherwise agreed between TSD and customer, TSD will replace or repair any of its LCD and LCM which TSD found to be defective electrically and visually when inspected in accordance with TSD Quality Standards, for a period of one year from date of shipment.

14.5.2 The warranty liability of TSD is limited to repair and/or replacement. TSD will not be responsible for any consequential loss.

14.5.3 If possible, we suggest you use up all modules in six months. If the module storage time over twelve months, we suggest that recheck it before the module be used.

## 15 Packaging

TBD

## 16 Prior Consult Matter

1. For TSD standard products, we keep the right to change material, process for improving the product property without prior notice to our customer.

2. For OEM products, if any changes are needed which may affect the product property, we will consult with our customer in advance.

3. If you have special requirement about reliability condition, please let us know before you start the test on our samples.

### Reference

Item	Description	Revision
ST7789V2	IC Data sheet	ST7789V2 SPEC
TST108102	LCM assembly drawing	V0