

PROPRIETARY NOTE

THIS SPECIFICATION IS THE PROPERTY OF BOE HF AND SHALL NOT BE REPRODUCED OR COPIED WITHOUT THE WRITTEN PERMISSION OF BOE HF AND MUST BE RETURNED TO BOE HF UPON ITS REQUEST



SPEC. NUMBER
S801-5126

PRODUCT GROUP
TFT- LCD

REV.
0

ISSUE DATE
2020.09.16

PAGE
1 OF 26

GT080S0M-N11-1QP0-Product Specification Rev.0

SUPPLIER	
FG-Code	GT080S0M-N11-1QP0 模组厂FG-CODE :2021080BSV020001-01D

ITEM	BUYER SIGNATURE	DATE
_____	_____	_____
_____	_____	_____
_____	_____	_____

ITEM	SUPPLIER SIGNATURE	DATE
Prepared	_____	_____
Reviewed	_____	_____
Approved	_____	_____

Contents

No.	Items	Page
1.0	General Description	4
2.0	Absolute Maximum ratings	6
3.0	Electrical specifications.	7
4.0	Interface Connection	9
5.0	Signal Timing Specifications	11
6.0	Signal Timing Waveforms Of Interface Signal	13
7.0	Power Sequence	15
8.0	Optical specifications.	16
9.0	Mechanical Outline Dimension	20
10.0	Reliability Test	21
11.0	Precautions	22
12.0	Label	26

1.0 GENERAL DESCRIPTION

1.1 Introduction

2021080BSV020001-01D is a color active matrix TFT LCD module using amorphous silicon TFT's (Thin Film Transistors) as an active switching devices. This module has a 8 inch diagonally measured active area with XGA resolutions (800horizontal by 600 vertical pixel array). Each pixel is divided into RED, GREEN, BLUE dots which are arranged in vertical stripe and this module can display 16.2 M colors.

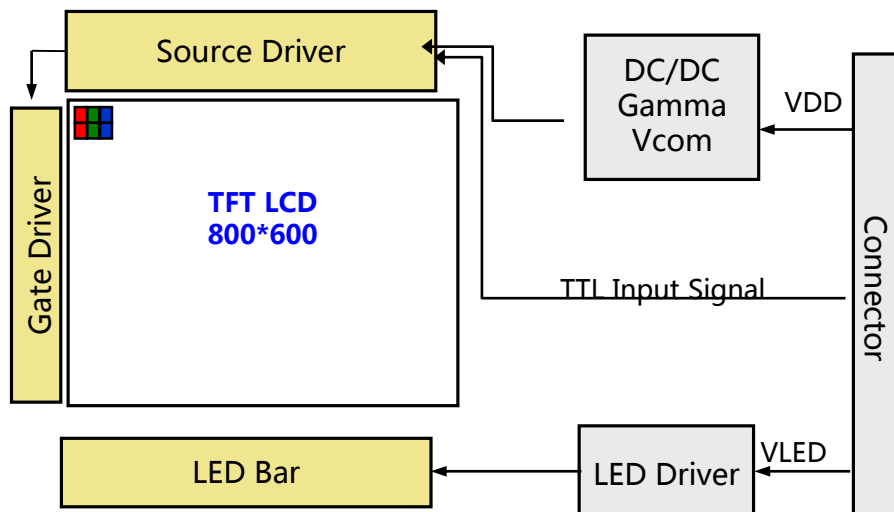

1.2 Features

- LED back-light
- TTL interface
- RoHS Compliant

1.3 Application

- Industrial control

1.4 General Specification

< Table 1. General Specifications >

Parameter	ITEMS	Unit	Remarks
Active area	162.0 (H) × 121.5(V)	mm	
Number of pixels	800(H) × 600(V)	Pixels	
Pixel pitch	67.5(H) × 202.5(V) × RGB	um	
Pixel arrangement	RGB Vertical stripe	-	
Display colors	16.7M	Colors	
Display mode	Normally White	-	
Dimensional outline	183.0 (H) × 141.0(V) × 5.6(D) typ.	Mm	
Surface treatment	Anti-Glare	-	
Back-light	Edge side, 1-LED Lighting Bar Type	-	

2.0 ABSOLUTE MAXIMUM RATINGS

The followings are maximum values which, if exceed, may cause faulty operation or damage to the unit. The operational and non-operational maximum voltage and current values are listed in Table 2.

< Table 2. Environment Absolute Maximum Ratings> [Ta =25 ± 2 °C]

Parameter	Symbol	Min.	Max.	Unit	Remarks
Back-light Power Supply Voltage	HV _{DDOUT}	-0.3	24	V	Ta = 25 °C Note 1&2
Back-light LED Reverse Voltage	V _R	-	12.8	V	
Operating Temperature	T _{OP}	-20	70	°C	Environment Temperature
Storage Temperature	T _{ST}	-30	80	°C	

Note:

1. These range above is maximum value not the actual operating temperature . Actual Operating temperature is no more than 40°C and temperature refers to the LCM surface temperature ;
2. BOE is not responsible for product problems beyond the use conditions.
3. When the ambient temperature is T °C, the surface temperature of Panel can not exceed (T+15)°C.

3.0 ELECTRICAL SPECIFICATIONS

3.1 TFT LCD Module

< Table 3. LCD Module Electrical Specifications >

[Ta =25 ± 2 °C]

Parameter	Symbol	Values			Unit	Notes
		Min	Typ	Max		
Power Supply Input Voltage	V _{DD}	3.0	3.3	3.6	V	Note 1
Power Supply Current	I _{DD}	-	120	-	mA	
Analog Supply Voltage	AVDD	9.5	10	10.5	V	Note 1
Analog Current	I _{AVDD}	-	30.5	-	mA	
Gate On Voltage	VGH	20	21	22	V	
Gate on Current	I _{VGH}	-	0.5	-	mA	
Gate Off Voltage	VGL	-7.98	-7.78	-7.58	V	
Gate off Current	I _{VGL}	-	4.21	-	mA	
Common Voltage	V _{com}	3.38	3.58	3.78	V	Note 2

Notes :

- The supply voltage is measured and specified at the interface connector of LCM.
The current draw and power consumption specified is for 3.3V at 25 °C
Max value at Black Pattern
- TYP VCOM is only reference value. It must be optimized according to each LCM. Be sure to use VR and OP buffer on VCOM output. Please adjust VCOM to make the flicker level be minimum for getting excellent image.

3.2 Back-light Unit

< Table 4. LED Driving guideline specifications >

Ta=25+/-2°C

Parameter		Min.	Typ.	Max.	Unit	Remarks
Power supply voltage for Back light	V _{LED}	10.8	12	12.8	V	
Power supply Current for Back light	I _{LED}	-	100	-	mA	
Power supply for Back light	P _{LED}	-	1.2	-	W	Note 1

Internal Circuit Diagram

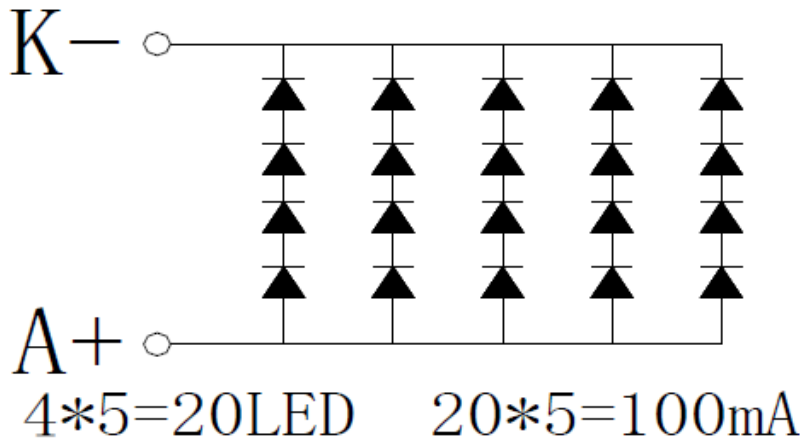

Notes : 1. Calculator Value for reference $I_{LED} \times V_{LED} = P_{LED}$

2. The LED Life-time define as the estimated time to 50% degradation of initial luminous under the condition of the ambient temperature of 25°C.

4.0 INTERFACE CONNECTION.

4.1 Electrical Interface Connection

FPC connector:FPC50-T1T1-2021-A or equal

<Table 5. Pin Assignments for the Interface Connector>

Terminal	Symbol	Functions
1	LED+	Power for LED backlight (Anode)
2	LED+	Power for LED backlight (Anode)
3	LED-	Power for LED backlight (Cathode)
4	LED-	Power for LED backlight (Cathode)
5	GND	Power ground
6	VCOM	Common voltage
7	DVDD	Digital Power
8	MODE	DE/SYNC mode select. Normally pull high
9	DE	Data Input Enable
10	VS	Vertical sync input. Negative polarity
11	HS	Horizontal sync input. Negative polarity
12~19	B7~B0	Blue data
20~26	G7~G0	Green data
27~35	R7~R0	RED data
36	GND	Power Ground
37	DCLK	Dot data clock
38	GND	Power Ground
39	L/R	Left or Right Display Control
40	U/D	Up / Down Display Control
41	VGH(18)	Positive Power for TFT
42	VGL(-7.7)	Negative Power for TFT
43	AVDD(10)	Analog Power
44	RESET(3.3)	Global reset pin. Active low to enter reset state.
45	NC	No connection
46	VCOM(3.2)	Common voltage
47	DITHB	Dithering setting
48	GND	Power Ground
49~50	NC	No connection

4.2 Data Input Format

Figure 5. Pixel Format

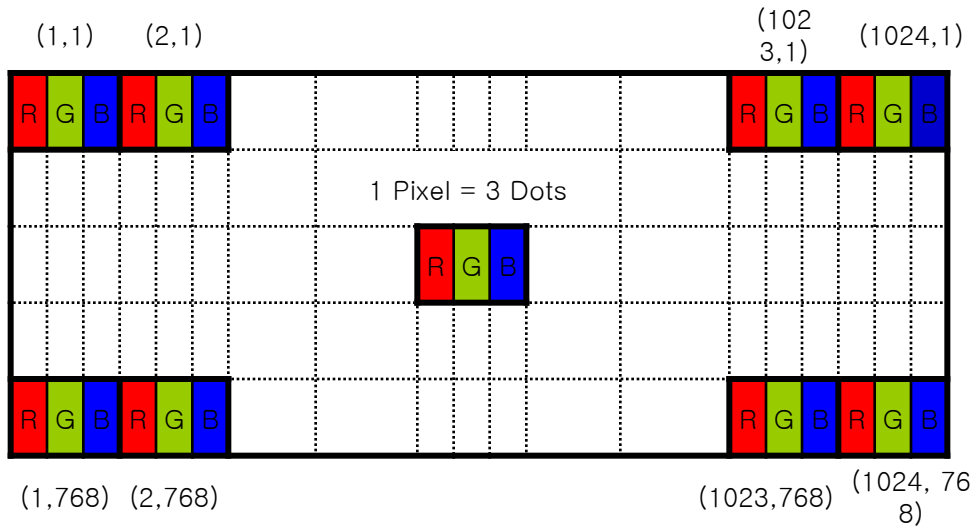

Display Position of Input Data (V-H)

Figure 6. Scan direction

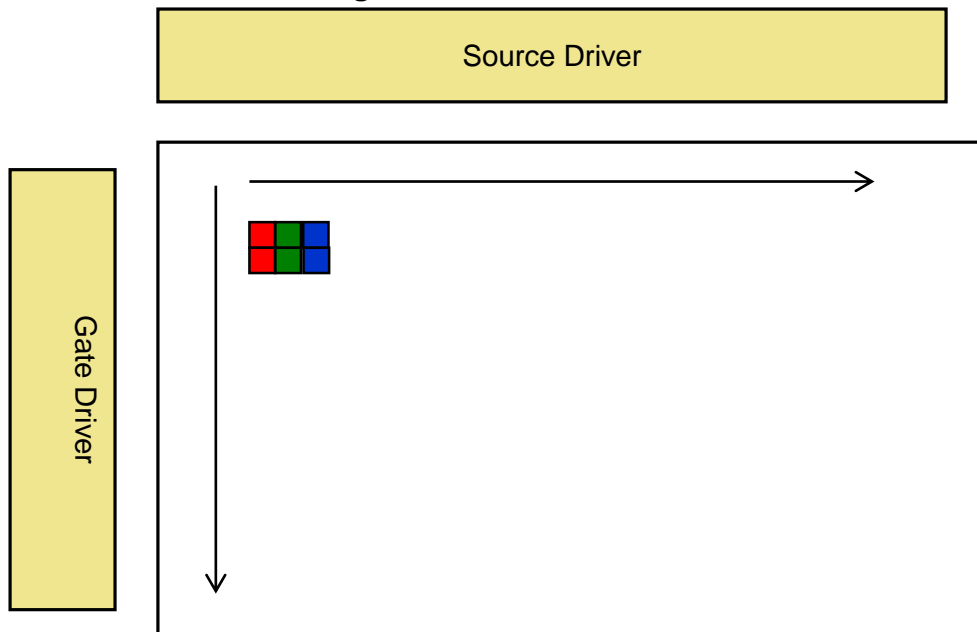

5.0 SIGNAL TIMING SPECIFICATION

5.1 The LCM input timing table

Horizontal timing

Parameter	Symbol	Spec.			Unit
		Min.	Typ.	Max.	
Horizontal Display Area	thd	800			DCLK
DCLK frequency	fclk	-	40	50	MHz
One Horizontal Line	th	889	1000	1143	DCLK
HS pulse width	thpw	1	48	255	DCLK
HS Back Porch (Blanking)	thb	88			DCLK
HS Front Porch	thfp	1	112	255	DCLK
DE mode Blanking	th-thd	85	200	512	DCLK

Vertical timing

Parameter	Symbol	Spec.			Unit
		Min.	Typ.	Max.	
Vertical Display Area	tvd	600			T _H
VS period time	tv	640	660	943	T _H
VS pulse width	tvpw	3	3	255	T _H
VS Back Porch (Blanking)	tvb	39			T _H
VS Front Porch	tvfp	1	21	255	T _H
DE mode Blanking	tv-tvd	4	60	255	T _H

Note: The DCLK range at last line of V-blanking should be set in 0-H-active/2.

5.2 TTL Rx Interface Timing Parameter

TTL mode data input format

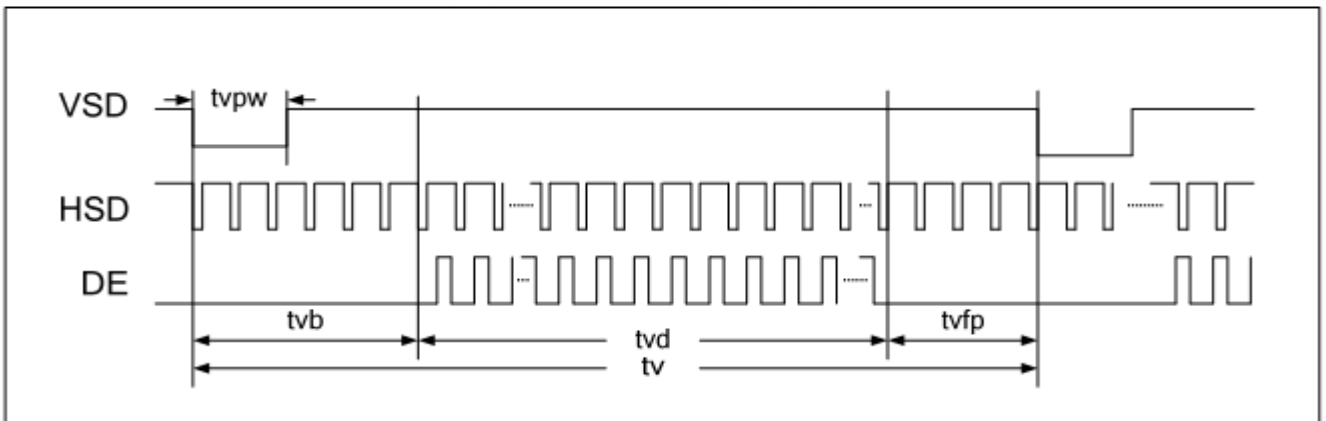
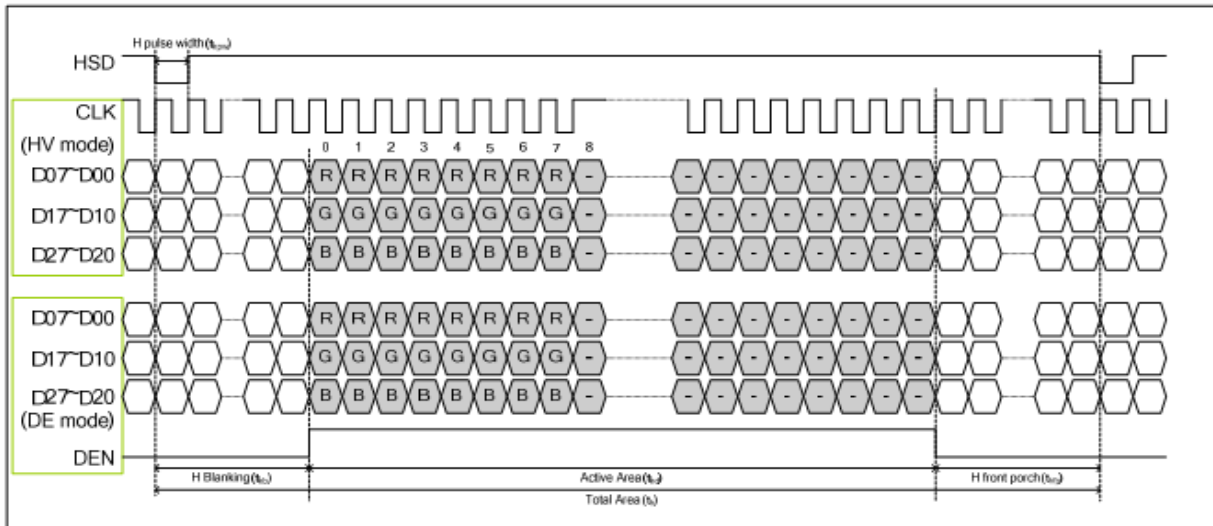

6.0 SIGNAL TIMING WAVEFORMS OF INTERFACE SIGNAL

6.1 Sync Timing Waveforms

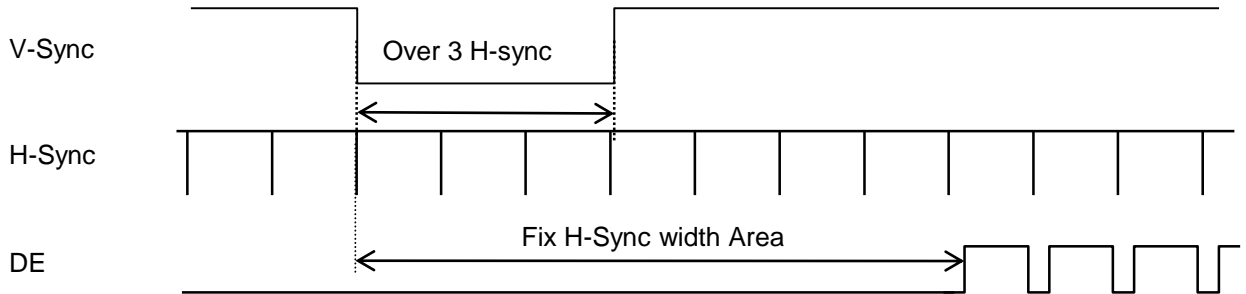

- 1) Need over 3 H-sync during V-Sync Low.
- 2) Fix H-Sync width from V-Sync falling edge to first rising edge.

6.2 Vertical Timing Waveforms

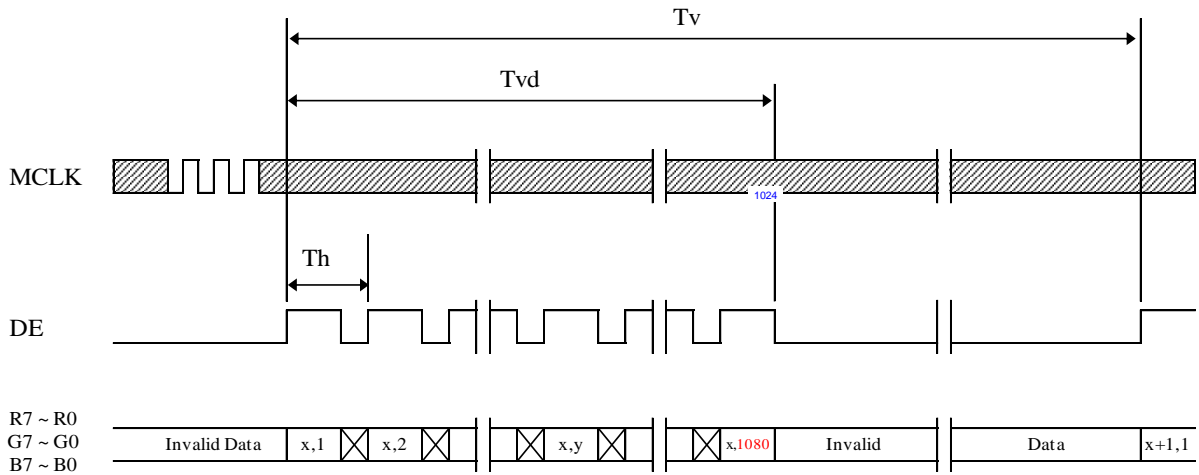

6.3 Horizontal Timing Waveforms

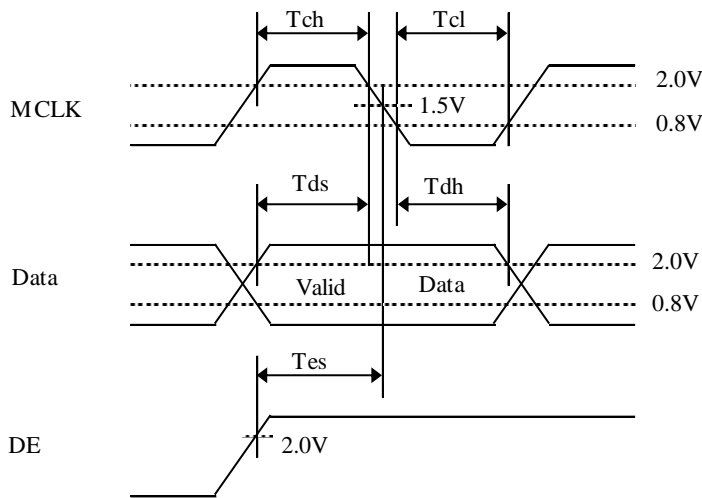
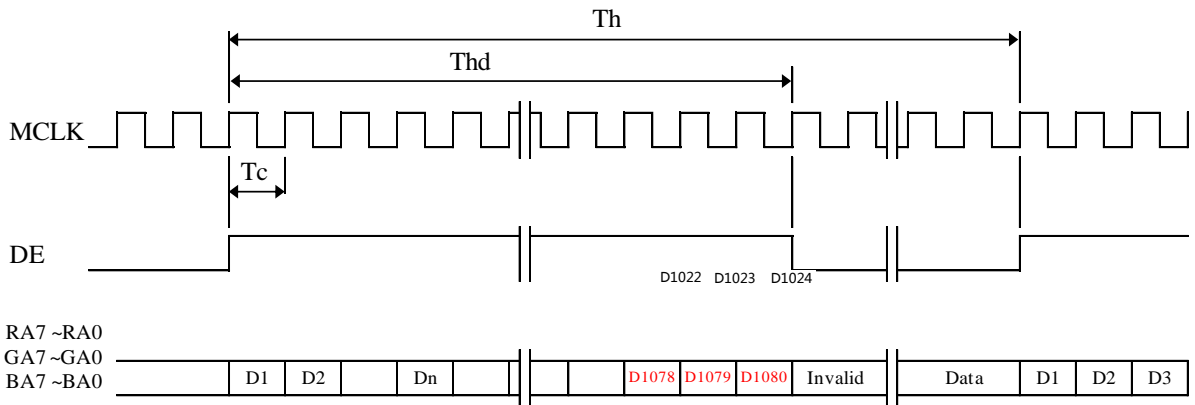

7.0 POWER SEQUENCE

To prevent a latch-up or DC operation of the LCD module, the power on/off sequence shall be as shown in below.

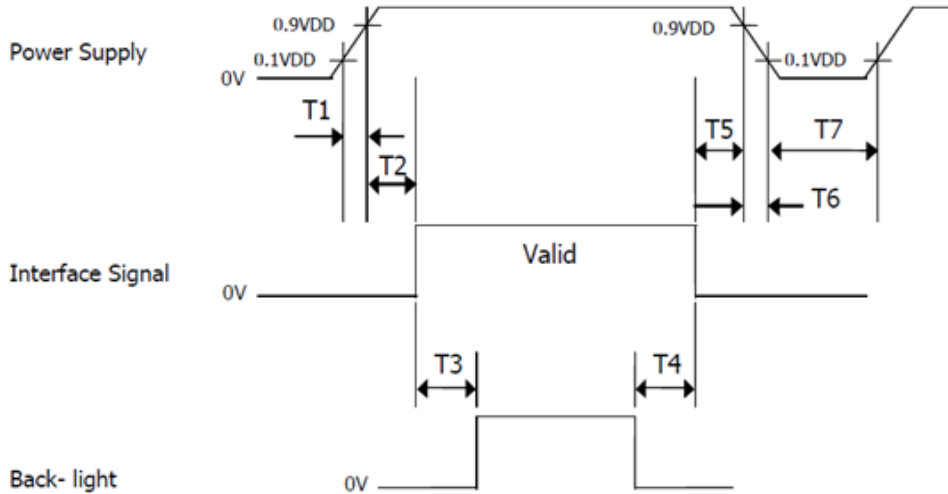

Parameter	Values			Units
	Min	Typ	Max	
T1	0	-	10	ms
T2	0	-	50	ms
T3	200	-	-	ms
T4	500	-	-	ms
T5	0	-	50	ms
T6	0	-	10	ms
T7	500	-	-	ms

8.0 OPTICAL SPECIFICATION

8.1 Overview

The test of view angle range shall be measured in a dark room (ambient luminance ≤ 1 lux and temperature = $25\pm 2^\circ\text{C}$) with the equipment of Luminance meter system (Goniometer system and TOPCON CS2000/CA310) and test unit shall be located at an approximate distance 50cm from the LCD surface at a viewing angle of θ and Φ equal to 0° . We refer to $\theta\Phi=0$ ($=\theta_3$) as the 3 o'clock direction (the "right"), $\theta\Phi=90$ ($=\theta_{12}$) as the 12 o'clock direction ("upward"), $\theta\Phi=180$ ($=\theta_9$) as the 9 o'clock direction ("left") and $\theta\Phi=270$ ($=\theta_6$) as the 6 o'clock direction ("bottom"). While scanning θ and/or Φ , the center of the measuring spot on the Display surface shall stay fixed. The luminance, color and uniformity (etc) should be tested by CS2000/CA310. The backlight should be operating for 10 minutes prior to measurement. VDD shall be $3.3 \pm 0.3\text{V}$ at 25°C .

<Table 5. Optical Specifications>

Parameter		Symbol	Condition	Min.	Typ.	Max.	Unit	Remark
Viewing Angle range	Horizontal	Θ_3	CR > 10	-	75	-	Deg.	Note 1
		Θ_9		-	75	-	Deg.	
	Vertical	Θ_{12}		-	75	-	Deg.	
		Θ_6		-	70	-	Deg.	
Luminance Contrast ratio		CR	$\Theta = 0^\circ$		500	-		Note 2
Luminance of White	Center	Y_w	$\Theta = 0^\circ$	200	250	-	cd/m ²	Note 3
Color Gamut	NTSC	CIE1931	$\Theta = 0^\circ$	-	50	-	%	Note 4
Reproduction of color	White	W_x	$\Theta = 0^\circ$	Typ -0.03	0.314	Typ +0.03		
		W_y			0.333			
Response Time		Tr+Td	Ta= 25°C $\Theta = 0^\circ$	-	20	40	ms	Note 5

Notes : 1. Viewing angle is the angle at which the contrast ratio is greater than 10. The viewing angles are determined for the horizontal or 3, 9 o'clock direction and the vertical or 6, 12 o'clock direction with respect to the optical axis which is normal to the LCD surface .

2. Contrast measurements shall be made at viewing angle of $\Theta = 0$ and at the center of the LCD surface. Luminance shall be measured with all pixels in the view field set first to white, then to the dark (black) state . (see FIGURE 1) Luminance Contrast Ratio (CR) is defined mathematically.

$$CR = \frac{\text{Luminance when displaying a white raster}}{\text{Luminance when displaying a black raster}}$$

3. Luminance of white is defined as luminance values of center of the LCD surface. Luminance shall be measured with all pixels in the view field set first to white. This measurement shall be taken at the locations shown in FIGURE 1 for a total of the measurements per display. The luminance is measured by CS2000/CA310 when the LED current is set at 100mA.
4. The color chromaticity coordinates specified in Table 5. shall be calculated from the spectral data measured with all pixels first in red, green, blue and white. Measurements shall be made at the center of the panel.
5. The electro-optical response time measurements shall be made as FIGURE 2 . The times needed for the, luminance to change from 10% to 90% is T_r , and 90% to 10% is T_f .

8.2 Optical measurements

Figure 1. Measurement Set Up

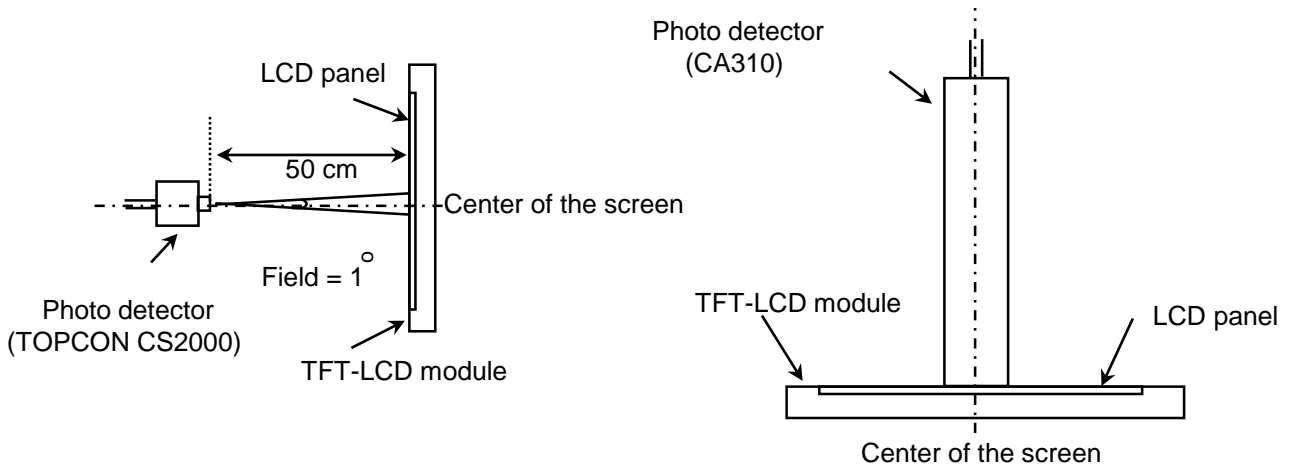

View angle range, uniformity, etc. measurement setup

Flicker, measurement setup

Figure 2. Response Time Testing

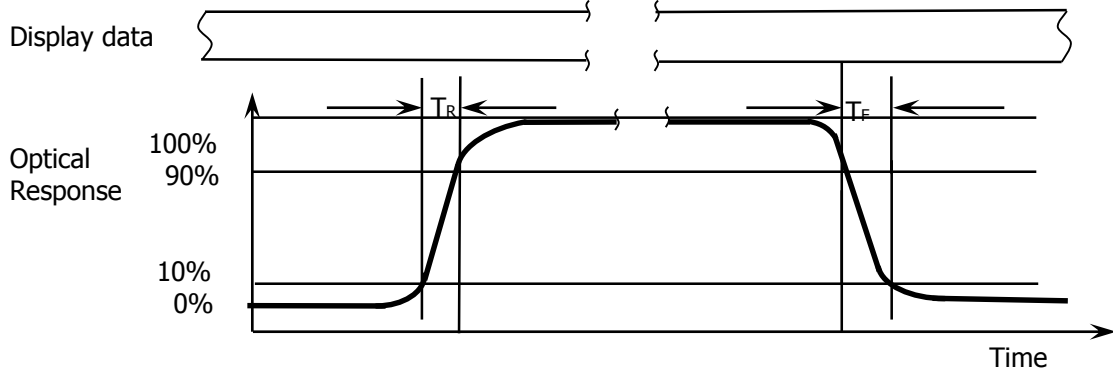

The electro-optical response time measurements shall be made as shown in FIGURE 2. The times needed for the luminance to change from 10% to 90% is T_r and 90% to 10% is T_f .

9.0 MECHANICAL OUTLINE DIMENSION

Figure 1. TFT-LCD Module Outline Dimension (Front View)

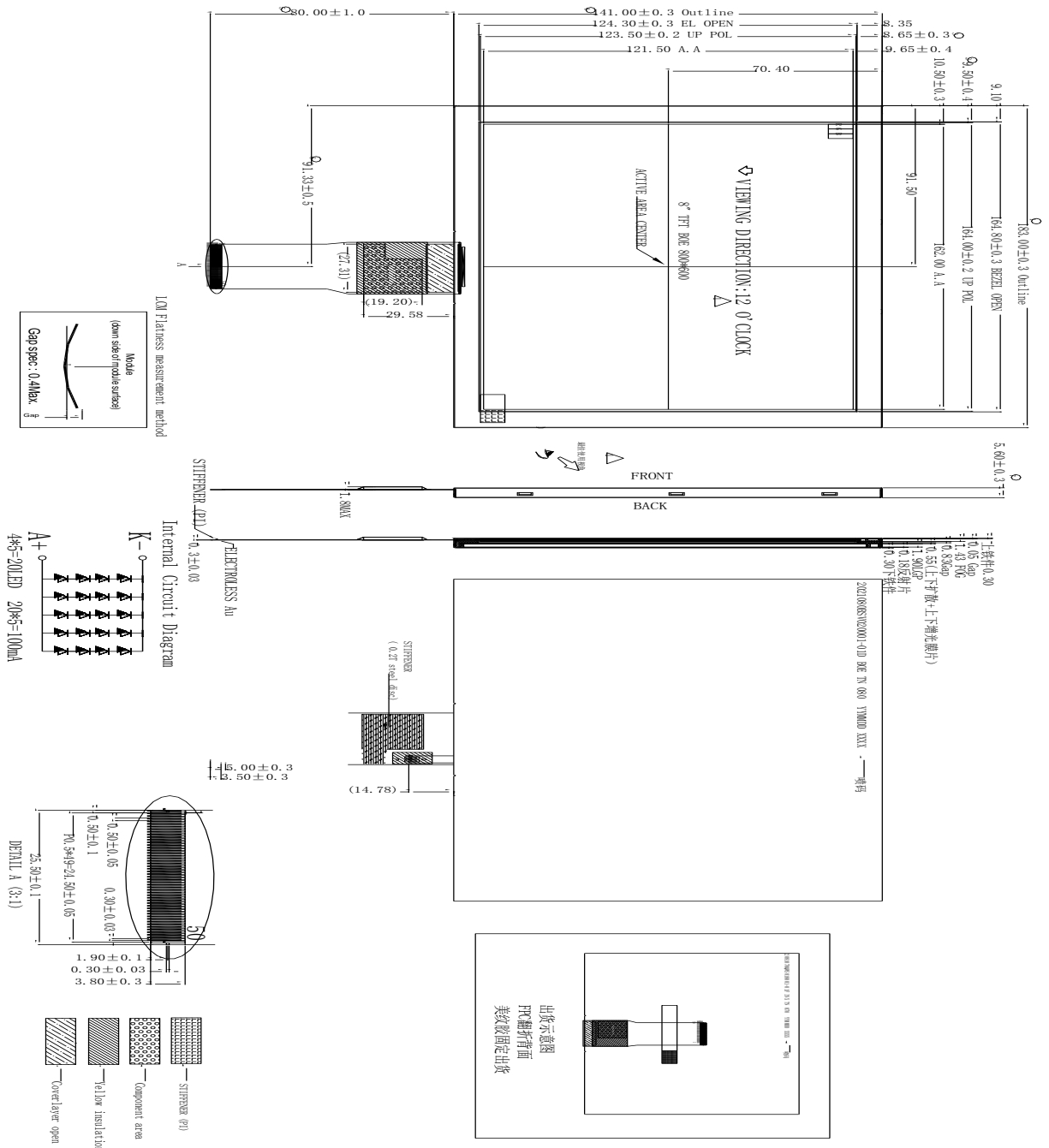

10.0 RELIABILITY TEST

The Reliability test items and its conditions are shown in below.

<Table 9. Reliability test>

No	Test Items	Conditions	Remark
1	High temperature storage test	Ta = 80°C, 240 hrs	
2	Low temperature storage test	Ta = -30 °C, 240 hrs	
3	High temperature operation test	Ta = 70°C, 240 hrs	
4	Low temperature operation test	Ta = -20 °C, 240 hrs	
5	High temperature & high humidity operation test	Ta = 60 °C, 90%RH, 120 hrs	
6	Thermal shock	Ta = -30 °C ↔ 80°C (0.5 hr), 100 cycle	Non-operation
7	Drop	Height:60cm 1 corner,3edges,6surfaces	
8	Package Vibration Test	Random Vibration: 0.015G*G/Hz from 5-200Hz,-6dB/Octave from 00-500HZ 2 hours for each direction of X.Y.Z (6 hours for total)	

Note : After the reliability test, the product only guarantee function normally without any fatal defect (non-display, line defect, abnormal display etc). All the cosmetic specification is judged before the reliability test.

11.0 Precautions

Please pay attention to the followings when you use this TFT LCD Panel.

11.1 Mounting Precautions

- (1) Use fingerstalls with soft gloves in order to keep display clean during the incoming inspection and assembly process.
- (2) You must mount a module using specified mounting holes (Details refer to the drawings).
- (3) Please make sure to avoid external forces applied to the Source PCB or FPC and D-IC during the process of handling or assembling. If not, It causes panel damage or malfunction.
- (4) Note that LCD surface are very fragile and could be easily damaged. Do not touch, push or rub the exposed LCD surface with glass, tweezers or anything harder than HB pencil lead. And please do not rub with dust clothes with chemical treatment.
- (5) Do not pull or fold the source D-IC which connect the source PCB or FPC and the panel. Do not pull or fold the LED wire.
- (6) After removing the protective film, when the surface becomes dusty, please wipe gently with absorbent cotton or other soft materials like chamois soaks with alcohol or purified water. Do not strong polar solvent because they cause chemical damage to the LCD surface
- (7) Wipe off saliva or water drops as soon as possible. Their long time contact with LCD surface causes deformations and color fading.
- (8) Since the LCD is made of glass, do not apply strong mechanical impact or static load onto it. Handling with care since shock, vibration, and careless handling may seriously affect the product. If it falls from a high place or receives a strong shock, the glass may be broken.
- (9) Do not disassemble the module.
- (10) To determine the optimum mounting angle, refer to the viewing angle range in the specification for each model.
- (11) If the customer's set presses the main parts of the LCD, the LCD may show the abnormal display. But this phenomenon does not mean the malfunction of the LCD and should be pressed by the way of mutual agreement.
- (12) Do not drop water or any chemicals onto the LCD's surface.

11.2 Operating Precautions

- (1) Be careful for condensation at sudden temperature change. Condensation makes damage to polarizer or electrical contacted parts. And after fading condensation, smear or spot will occur.
- (2) Module has high frequency circuits. Sufficient suppression to the electromagnetic interference shall be done by system manufacturers. Grounding and shielding methods may be important to minimized the interference.
- (3) The electrochemical reaction caused by DC voltage will lead to LCD degradation, so DC drive should be avoided.
- (4) The LCD modules use C-MOS LSI drivers, so customers are recommended that any unused input terminal would be connected to Vdd or Vss, do not input any signals before power is turn on, and ground you body, work/assembly area, assembly equipments to protect against static electricity.
- (5) Do not exceed the absolute maximum rating value. (supply voltage variation, input voltage variation, variation in part contents and environmental temperature, and so on) Otherwise the Module may be damaged.
- (6) Design the length of cable to connect between the connector for back-light and the converter as short as possible and the shorter cable shall be connected directly.
The longer cable between that of back-light and that of converter may cause the luminance of LED to lower and need a higher startup voltage(Vs).
- (7) Connectors are precise devices for connecting PCB and transmitting electrical signals. Operators should insert and unplug MDL in parallel when assembling MDL.
- (8) Do not connect or disconnect the cable to/ from the module at the "Power On" condition.
- (9) When the module is operating, do not lose CLK, ENAB signals. If any one these signals is lost, the LCD panel would be damaged.
- (10) Obey the supply voltage sequence. If wrong sequence is applied, the module would be damaged.
- (11) Do not re-adjust variable resistor or switch etc.

11.3 Electrostatic Discharge Control

- (1) Since a module is composed of electronic circuits, it is not strong to electrostatic discharge. Make certain that treatment persons are connected to ground through wrist band etc. And don't touch interface pin directly. Keep products as far away from static electricity as possible.
- (2) Avoid the use work clothing made of synthetic fibers. We recommend cotton clothing or other conductivity-treated fibers.

11.4 Precautions for Extreme Outdoor Environments

Products should be protected against extreme high or low temperature, water vapor and ultraviolet radiation. Products need to avoid prolonged exposure to extreme outdoor environments.

11.5 Storage Precautions

When storing modules as spares for a long time, the following precautions are necessary.

(1) The **polarizer** surface should not come in contact with any other object.

It is recommended that they be stored in the container in which they were shipped.

Temperature : 5 ~ 40 °C

(2) Humidity : 35 ~ 75 %RH

(3) Period : 6 months

(4) Control of ventilation and temperature is necessary.

(5) Please make sure to protect the product from strong light exposure, water or moisture.

Be careful for condensation.

(6) Store in a polyethylene bag with sealed so as not to enter fresh air outside in it.

(7) Do not store the LCD near organic solvents or corrosive gasses.

(8) Please keep the **Modules/OC/FOG** at a circumstance shown below Fig.

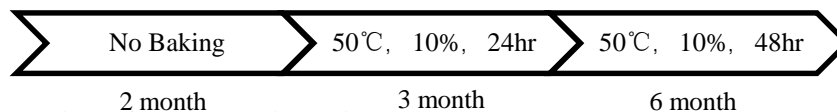

11.6 Precautions for Protection Film (适用通用产品, 含Q/Single Production)

(1) Remove the protective film slowly, keeping the removing direction approximate 30-degree not vertical from panel surface, If possible, under ESD control device like ion blower, and the humidity of working room should be kept over 50%RH to reduce the risk of static charge.

(2) In handling the LCD, wear non-charged material gloves. And the conducting wrist to the earth and the conducting shoes to the earth are necessary.

11.7 Appropriate Condition for Display

(1) Normal operating condition

-Temperature: 0 ~ 40°C

-Operating Ambient Humidity : 10 ~ 90 %

-Display pattern: dynamic pattern (Real display)

-Long-term lighting products recommended regular shutdown

(2) Special operating condition

If the product will be used in extreme conditions such as high temperature, humidity, display patterns or 7*24hrs operation time etc., It is strongly recommended to contact BOE for Application engineering advice. Otherwise, its reliability and function may not be guaranteed.

(3) Black image or moving image is strongly recommended as a screen save.

- (4) Lifetime in this spec. is guaranteed only when commercial display is used according to operating usages.
- (5) Please contract BOE in advance when you want to switch between portrait and landscape
- (6) Please contact BOE in advance when you display the same pattern for a long time.
- (7) If the Module keeps displaying the same pattern for a long period of time, the image may be "sticked" to the screen. To avoid image sticking, it is recommended to use a screen saver.
- (8) Do not exceed the absolute maximum rating value. (supply voltage variation, input voltage variation, variation in part contents and environmental temperature, and so on) Otherwise the Module may be damaged.
- (9) Dew drop atmosphere should be avoided.
- (10) The storage room should be equipped with a good ventilation facility and avoid to expose to corrosive gas , which has a temperature controlling system.
- (11) When expose to drastic fluctuation of temperature (hot to cold or cold to hot) ,the LCD may be affected; Specifically, drastic temperature fluctuation from cold to hot ,produces dew on the LCD's surface which may affect the operation of the polarizer and the LCD.
- (12) Response time will be extremely delayed at lower temperature than the operating temperature range and on the other hand at higher temperature LCD may turn black at temperature above its operational range. However those phenomena do not mean malfunction or out of order with the LCD. The LCD will revert to normal operation once the temperature returns to the recommended temperature range for normal operation

11.8 Others

A. LC Leak

- If the liquid crystal material leaks from the panel, it is recommended to wash the LC with acetone or ethanol and then burn it.
- In case of contact with hands, skin or clothes, it has to be washed away thoroughly with soap.
- If LC in mouth, mouth need to be washed, drink plenty of water to induce vomiting and follow medical advice.
- If LC touch eyes, eyes need to be washed with running water at least 15 minutes.

B. Rework

- When returning the module for repair or etc., Please pack the module not to be broken. We recommend to use the original shipping packages.

12.0 label

Drawing Of Marks

批号/批组批号: 201808022001-01E	XXXXXX
Customer Part No./客户号: QIM Q17 数量:	XXXXXX
生产年月/生产日期: XXXX-YY-DD	XXXXXX in MS XXXXXXXXXX

唛头图

图案说明:
XXXX-YY-DD 即为生产年月日
包装数量: 按实际包装数量打印
客户料号: 营销提供

备注: LCM模组拆包部分注意事项

1. 拆开纸箱, 拿出一包 LCM模组, 取出一片 LCM 模组
2. 撕取 LCM 模组表面保护膜: 拿住鼻端贴手柄, 沿右下角与左上角的对角线方向撕取保护膜, 速度约 5S/PCS. 同时, 撕取时需用离子风机吹模组表面, 风向沿撕取方向

LCM模组上盖
与右下侧撕取
角线

离子风机

上面两凹槽用 2PCS 珍珠棉固定产品, 下面凹槽使用 2PCS 纸隔纸固定产品

将 PPES 模组产品装在一个开口塑料袋中, 将袋口卷折。

将 2PCS 产品中间夹 1 层 5mm 的珍珠棉后放入纸板格子, 共计 64pcs

使用封口胶封口并贴附唛头

包材请回收!

封箱胶纸