

**MODEL NO :** TM070JDHG30  
**MODEL VERSION:** 00  
**SPEC VERSION :** 2.4  
**ISSUED DATE:** 2023-03-24

- Preliminary Specification  
 Final Product Specification

Customer :

| Approved by | Note |
|-------------|------|
|             |      |

TIANMA Confirmed :

| Prepared by | Checked by    | Approved by |
|-------------|---------------|-------------|
| Junwen Du   | Longping Deng | Feng Qin    |

This technical specification is subjected to change without notice.

# Table of Contents

|   |    |
|---|----|
| 1. General Specification.....               | 3  |
| 2. Input/output Terminals .....             | 4  |
| 3. Absolute Maximum Ratings .....           | 6  |
| 4. Electrical Characteristics .....         | 7  |
| 5. Timing Chart.....                        | 11 |
| 6. Optical Characteristics.....             | 16 |
| 7. Reliability Test.....                    | 19 |
| 8. Mechanical Drawing .....                 | 21 |
| 9. Packing Drawing .....                    | 22 |
| 10. Precautions for Use of LCD Modules..... | 23 |

**Record of Revision**

| <b>Rev</b> | <b>Issued Date</b> | <b>Description</b>                | <b>Editor</b> |
|------------|--------------------|-----------------------------------|---------------|
| 2.0        | 2016-06-06         | Final Specification release       | Junwen Du     |
| 2.1        | 2016-06-17         | Add the VGH etc. electric current | Junwen Du     |
| 2.2        | 2018-03-15         | Update Power on/off Timing        | Jinzhe Zhao   |
| 2.3        | 2021-04-28         | Modify Vcom min/typ/max value     | Xiaohui.zhou  |
| 2.4        | 2023-03-24         | Update Packing Drawing            | Lixian.Xu     |
|            |                    |                                   |               |
|            |                    |                                   |               |
|            |                    |                                   |               |
|            |                    |                                   |               |
|            |                    |                                   |               |
|            |                    |                                   |               |
|            |                    |                                   |               |
|            |                    |                                   |               |
|            |                    |                                   |               |
|            |                    |                                   |               |
|            |                    |                                   |               |
|            |                    |                                   |               |
|            |                    |                                   |               |

**1 General Specification**

| <b>Item</b> | <b>Feature</b> | <b>Spec</b> |
|-------------|----------------|-------------|
|-------------|----------------|-------------|

The information contained herein is the exclusive property of TIANMA MICRO-ELECTRONICS Corporation, and shall not be distributed, reproduced, or disclosed in whole or in part without prior written permission of TIANMA MICRO-ELECTRONICS Corporation.

|                                   |                                 |                         |
|-----------------------------------|---------------------------------|-------------------------|
| <b>Display Spec.</b>              | Size                            | 7                       |
|                                   | Resolution                      | 1280(RGB) x 800         |
|                                   | Technology Type                 | a-Si                    |
|                                   | Pixel Pitch(mm)                 | 0.117 x 0.117           |
|                                   | Pixel Configuration             | R.G.B. Vertical Stripe  |
|                                   | Display Mode                    | SFT with Normally Black |
|                                   | Surface Treatment(Up Polarizer) | HC                      |
| <b>Mechanical Characteristics</b> | LCM (W x H x D) (mm)            | 161.0×107.0×3.35(Typ)   |
|                                   | Active Area(W x H) (mm)         | 149.76 x 93.60          |
|                                   | LED Numbers                     | 21 LEDs                 |
|                                   | Matching Connector Type         | Molex 54132-4062        |
|                                   | Weight(g)                       | 120 (Typ)               |
|                                   | Operation temperature           | -20~70℃                 |
|                                   | Storage temperature             | -30~80℃                 |
| <b>Electrical Characteristics</b> | Interface                       | LVDS 40 Pin             |
|                                   | Color Depth                     | 16.7M                   |
|                                   | Driver IC                       | 3*ST5821C and 1*ST5084C |

Note 1: Requirements on Environmental Protection: Q/S0002

## 2. Input/output Terminals

### 2.1 TFT CN1 pin assignment

The information contained herein is the exclusive property of TIANMA MICRO-ELECTRONICS Corporation, and shall not be distributed, reproduced, or disclosed in whole or in part without prior written permission of TIANMA MICRO-ELECTRONICS Corporation.

| Pin No. | Symbol   | I/O | function                          | Remarks |
|---------|----------|-----|-----------------------------------|---------|
| 1       | NC       | --  | No connection                     |         |
| 2       | VDD      | P   | Power Voltage for digital circuit |         |
| 3       | VDD      | P   | Power Voltage for digital circuit |         |
| 4       | NC       | --  | No connection                     |         |
| 5       | NC       | --  | No connection                     |         |
| 6       | NC       | --  | No connection                     |         |
| 7       | GND      | P   | Ground                            |         |
| 8       | RXIN0-   | I   | - LVDS differential data input    |         |
| 9       | RXIN0+   | I   | +LVDS differential data input     |         |
| 10      | GND      | P   | Ground                            |         |
| 11      | RXIN1-   | I   | -LVDS differential data input     |         |
| 12      | RXIN1+   | I   | +LVDS differential data input     |         |
| 13      | GND      | P   | Ground                            |         |
| 14      | RXIN2-   | I   | -LVDS differential data input     |         |
| 15      | RXIN2+   | I   | +LVDS differential data input     |         |
| 16      | GND      | P   | Ground                            |         |
| 17      | RXCLKIN- | I   | -LVDS differential clock input    |         |
| 18      | RXCLKIN+ | I   | +LVDS differential clock input    |         |
| 19      | GND      | P   | Ground                            |         |
| 20      | RXIN3-   | I   | -LVDS differential data input     |         |
| 21      | RXIN3+   | I   | +LVDS differential data input     |         |
| 22      | GND      | P   | Ground                            |         |
| 23      | NC       | --  | No connection                     |         |
| 24      | NC       | --  | No connection                     |         |
| 25      | GND      | P   | Ground                            |         |
| 26      | NC       | --  | No connection                     |         |
| 27      | NC       | --  | No connection                     |         |
| 28      | NC       | --  | No connection                     |         |
| 29      | AVDD     | P   | Power for Analog Circuit          |         |
| 30      | GND      | P   | Ground                            |         |
| 31      | LED-     | P   | LED Cathode                       |         |
| 32      | LED-     | P   | LED Cathode                       |         |
| 33      | NC       | --  | No connection                     |         |
| 34      | NC       | --  | No connection                     |         |
| 35      | VGL      | P   | Gate Off Voltage                  |         |
| 36      | NC       | --  | No connection                     |         |
| 37      | NC       | --  | No connection                     |         |
| 38      | VGH      | P   | Gate On Voltage                   |         |
| 39      | LED+     | P   | LED Anode                         |         |
| 40      | LED+     | P   | LED Anode                         |         |

Note1: I/O definition.

The information contained herein is the exclusive property of TIANMA MICRO-ELECTRONICS Corporation, and shall not be distributed, reproduced, or disclosed in whole or in part without prior written permission of TIANMA MICRO-ELECTRONICS Corporation.

I---Input, O---Output, P--- Power/Ground, N--- No connection

TIANMA CONFIDENTIAL

### 3. Absolute Maximum Ratings

GND=0V, Ta = 25°C

| Item          | Symbol | Min  | Max | Unit | Remark |
|---------------|--------|------|-----|------|--------|
| Power Voltage | VDD    | -0.5 | 5.0 | V    |        |

The information contained herein is the exclusive property of TIANMA MICRO-ELECTRONICS Corporation, and shall not be distributed, reproduced, or disclosed in whole or in part without prior written permission of TIANMA MICRO-ELECTRONICS Corporation.

|                           |                  |       |       |    |              |
|---------------------------|------------------|-------|-------|----|--------------|
|                           | AVDD             | -0.5  | 14.85 | V  |              |
|                           | VGH              | -0.3  | 20.0  | V  |              |
|                           | VGL              | -20.0 | 0.3   | V  |              |
| Backlight Forward Current | I <sub>LED</sub> | -     | 25    | mA | For each LED |
| Operating Temperature     | T <sub>OPR</sub> | -20   | 70    | °C |              |
| Storage Temperature       | T <sub>STG</sub> | -30   | 80    | °C |              |

**Table 3.1 Absolute maximum rating**

## 4 Electrical Characteristics

### 4.1 Driving TFT LCD Panel

#### 4.1.1 Voltage characteristic

Ta = 25°C

| Item                   | Symbol | Min | Typ | Max | Unit | Remark |
|------------------------|--------|-----|-----|-----|------|--------|
| Digital Supply Voltage | VDD    | 3.0 | 3.3 | 3.6 | V    |        |

The information contained herein is the exclusive property of TIANMA MICRO-ELECTRONICS Corporation, and shall not be distributed, reproduced, or disclosed in whole or in part without prior written permission of TIANMA MICRO-ELECTRONICS Corporation.

|                                 |      |      |      |      |   |                  |
|---------------------------------|------|------|------|------|---|------------------|
| Analog Supply Voltage           | AVDD | 10.5 | 11   | 11.5 | V |                  |
| Gate On Voltage                 | VGH  | 17.5 | 18.0 | 18.5 | V |                  |
| Gate Off Voltage                | VGL  | -7.1 | -6.8 | -6.5 | V |                  |
| Common Electrode Driving Signal | VCOM | 3.55 | 4.0  | 4.59 | V | With the VR Knob |

**Table 4.1 LCD module electrical characteristics(voltage)**

#### 4.1.2 current characteristic

| Item  | Min   | Typ   | Max   | Unit | Remark |
|-------|-------|-------|-------|------|--------|
| Ivdd  | 42.4  | 53    | 63.6  | mA   |        |
| Iavdd | 33.2  | 41.5  | 49.8  | mA   |        |
| Ivgh  | 0.326 | 0.408 | 0.490 | mA   |        |
| Ivgl  | 0.326 | 0.408 | 0.490 | mA   |        |
| Ivcom | 0.004 | 0.005 | 0.006 | mA   |        |

Nites: test in the white picture.

**Table 4.1 LCD module electrical characteristics(current)**

#### 4.2 TFT Driving Backlight

| Item                        | Symbol         | Condition             | Min | Typ  | Max  | Unit | Remark |
|-----------------------------|----------------|-----------------------|-----|------|------|------|--------|
| Forward Voltage             | VLED           | I <sub>F</sub> =140mA | --  | 9.3  | 10.2 | V    | -      |
| Forward Current             | I <sub>F</sub> | -                     | -   | 140  | -    | mA   |        |
| Backlight Power Consumption | WBL            | I <sub>F</sub> =140mA | --  | 1302 | 1428 | mW   |        |

The information contained herein is the exclusive property of TIANMA MICRO-ELECTRONICS Corporation, and shall not be distributed, reproduced, or disclosed in whole or in part without prior written permission of TIANMA MICRO-ELECTRONICS Corporation.



|           |   |                    |    |         |   |     |        |
|-----------|---|--------------------|----|---------|---|-----|--------|
| Life Time | - | $I_F=140\text{mA}$ | -- | 30,000- | - | Hrs | Note 1 |
|-----------|---|--------------------|----|---------|---|-----|--------|

**Table 4.2 LED backlight characteristics**

Note 1: If LED is driven by high current, high ambient temperature & humidity condition. The life time of LED will be reduced. Operating life means brightness goes down to 50% initial brightness. Typical operating life time is estimated data.

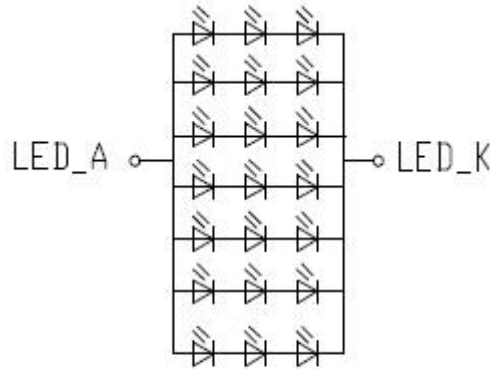

LED circuit  
 $V_f=9.3\text{V}$ ,  $I_f=140\text{mA}$

**Figure 4.1 LED connection of backlight**

4.3 TFT Block Diagram

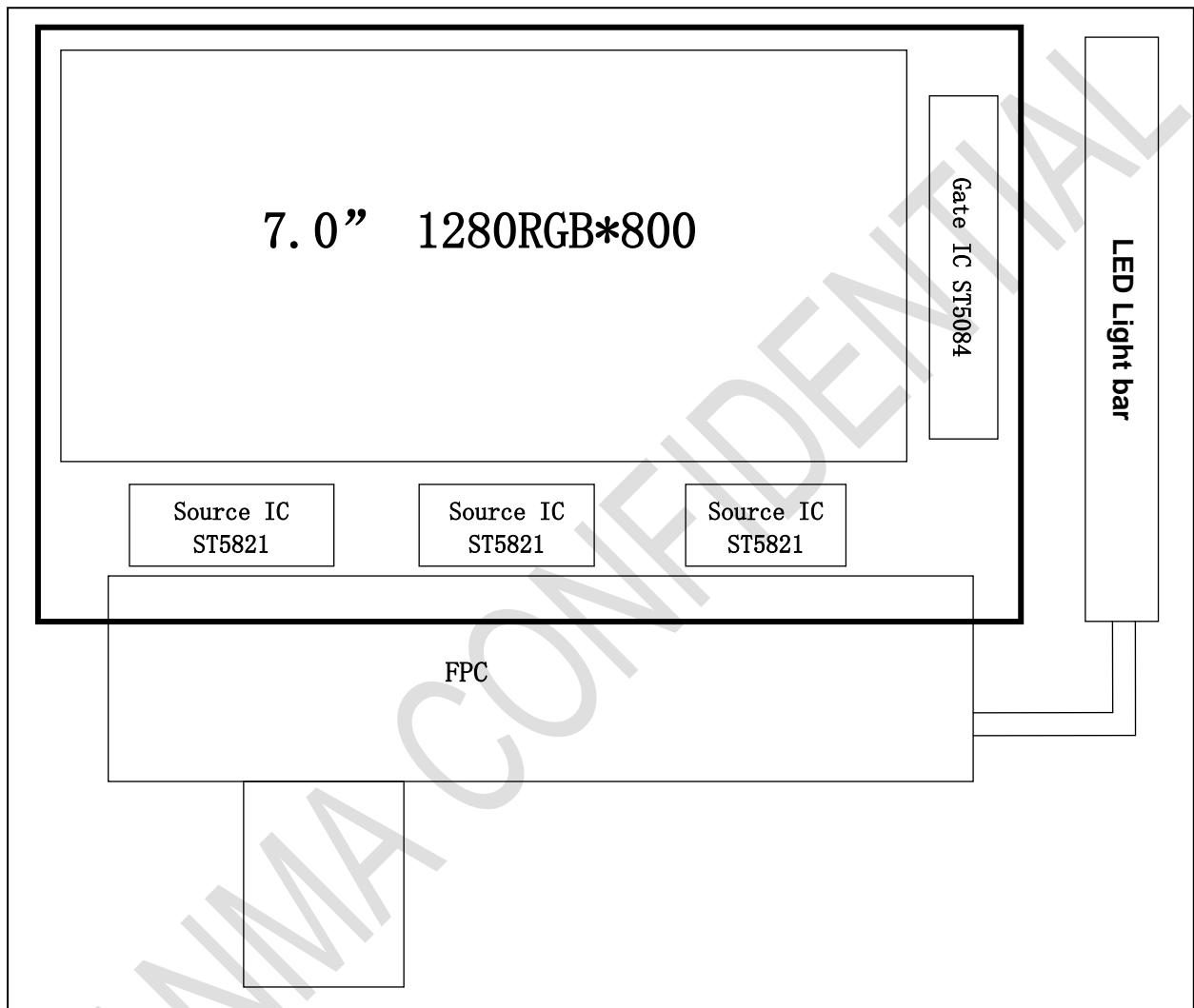

Figure 4.3 TFT Block Diagram

## 5. Timing Chart

### 5.1 AC Electrical Characteristics

| Parameter              | Symbol      | Min | Typ | Max | Unit        | Conditions  |
|------------------------|-------------|-----|-----|-----|-------------|---|
| Clock Frequency        | $R_{xFCLK}$ | 20  | -   | 80  | MHz         |   |
| Input data skew margin | $T_{RSKM}$  | 500 | -   | -   | ps          | $ V_{ID} = 400mV$ ,<br>$R_{xVCM}=1.2V$<br>$R_{xFCLK}=80MHz$ |
| Clock high time        | $T_{LVCH}$  | -   | 4/7 | -   | $R_{xFCLK}$ |   |
| Clock low time         | $T_{LVCL}$  | -   | 3/7 | -   | $R_{xFCLK}$ |   |
| PLL wake-up time       | $T_{enPLL}$ | -   | -   | 150 | us          |   |

Table 5.1 AC Electrical Characteristics

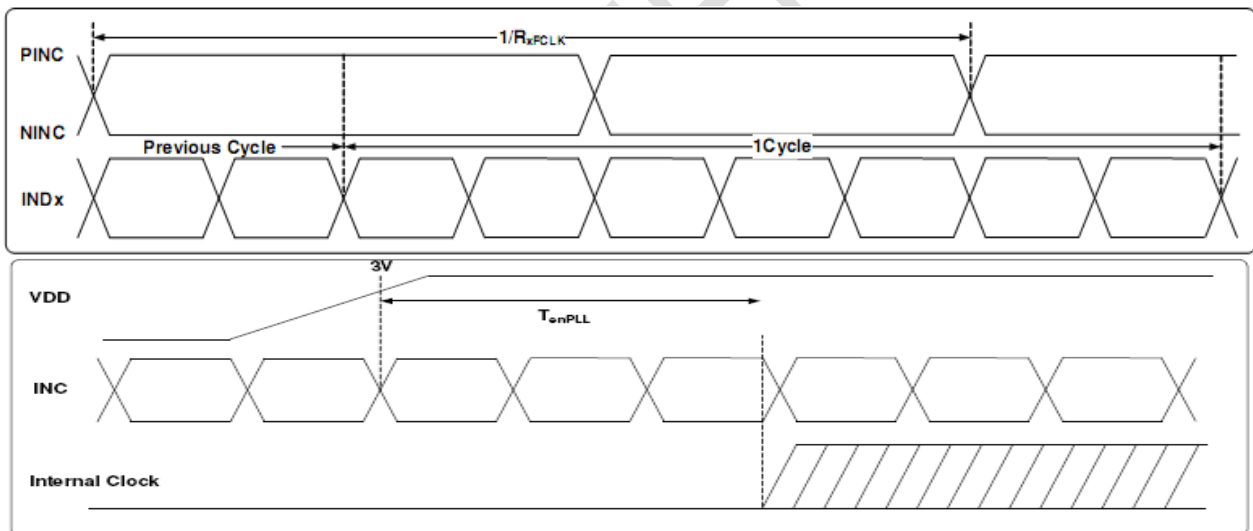

Figure 5.1 AC Electrical Characteristics

5.2 DC Electrical Characteristics

VGH=18V, VGL=-6.8V, VDD=3.3V, GND=0V, Ta=25°C

| Parameter                                 | Symbol         | Min          | Typ | Max                    | Unit | Remark                            |
|---|----------------|--------------|-----|------------------------|------|-----------------------------------|
| Differential input high Threshold voltage | $R_{XVTH}$     | -            | -   | +0.1                   | V    |                                   |
| Differential input Low Threshold voltage  | $R_{XVTL}$     | -0.1         | -   | -                      | V    |                                   |
| Input voltage range                       | $R_{XVIN}$     | 0            | -   | VDD-1.0                | V    |                                   |
| Differential input common Mode voltage    | $R_{XVCM}$     | $ V_{ID} /2$ | -   | $2.4 \cdot  V_{ID} /2$ | V    |                                   |
| Differential input voltage                | $ V_{ID} $     | 0.2          | --  | 0.6                    | V    |                                   |
| Differential input leakage Current        | $R_{V_{XlIZ}}$ | -10          | --  | +10                    | uA   |                                   |
| LVDS Digital Operating Current            | $I_{ddlvds}$   | -            | 40  | 50                     | mA   | Fclk=65MHz, VDD=3.3V              |
| LVDS Digital Stand-by Current             | $I_{stlvds}$   | -            | 10  | 50                     | uA   | Clock & all functions are stopped |

Table 5.2 DC Electrical Characteristics

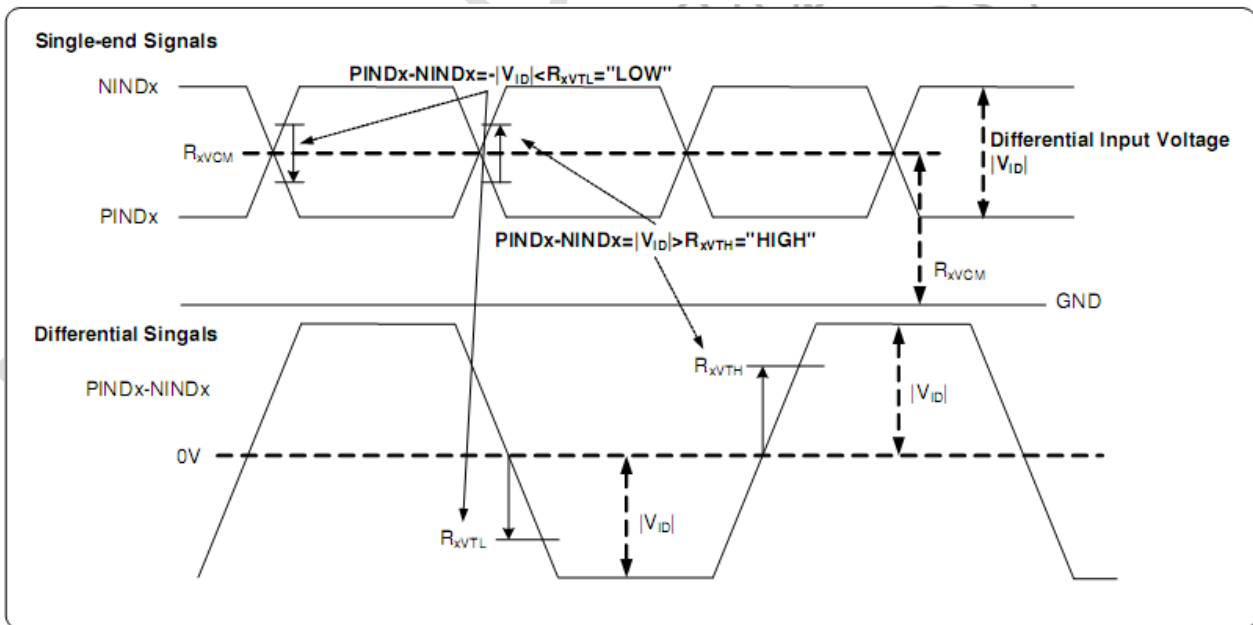

Figure 5.2 DC Electrical Characteristics

### 5.3 Input timing

1280x800 (RES[3:0] = 0010)

| Parameter                | Symbol           | Value |      |                       | Unit             | Note                                |
|--------------------------|------------------|-------|------|-----------------------|------------------|-------------------------------------|
|                          |                  | Min.  | Typ. | Max.                  |                  |                                     |
| CLK frequency            | t <sub>CLK</sub> | 62.6  | 68.2 | 78.1                  | Mhz              |                                     |
| Horizontal blanking time | t <sub>HBT</sub> | 20    | 69   | 164                   | t <sub>CLK</sub> | t <sub>HBP</sub> + t <sub>HFP</sub> |
| Horizontal back porch    | t <sub>HBP</sub> | 5     | 5    | 164- t <sub>HFP</sub> | t <sub>CLK</sub> |                                     |
| Horizontal display area  | t <sub>HD</sub>  | 1280  | 1280 | 1280                  | t <sub>CLK</sub> |                                     |
| Horizontal front porch   | t <sub>HFP</sub> | 15    | 64   | 159                   | t <sub>CLK</sub> |                                     |
| Horizontal period        | t <sub>H</sub>   | 1300  | 1349 | 1444                  | t <sub>CLK</sub> |                                     |
| Horizontal pulse width   | t <sub>HPW</sub> | 1     | 1    | 256                   | t <sub>CLK</sub> |                                     |
| Vertical blanking time   | t <sub>VBT</sub> | 5     | 42   | 101                   | t <sub>H</sub>   | t <sub>VBP</sub> + t <sub>VFP</sub> |
| Vertical back porch      | t <sub>VBP</sub> | 2     | 2    | 101- t <sub>VFP</sub> | t <sub>H</sub>   |                                     |
| Vertical display area    | t <sub>VD</sub>  | 800   | 800  | 800                   | t <sub>H</sub>   |                                     |
| Vertical front porch     | t <sub>VFP</sub> | 3     | 40   | 99                    | t <sub>H</sub>   |                                     |
| Vertical period          | t <sub>V</sub>   | 803   | 842  | 901                   | t <sub>H</sub>   |                                     |
| Vertical pulse width     | t <sub>VPW</sub> | 1     | 1    | 128                   | t <sub>H</sub>   |                                     |

Table 5.3 Input timing

### 5.4 Data Input Format

#### VESA data mapping

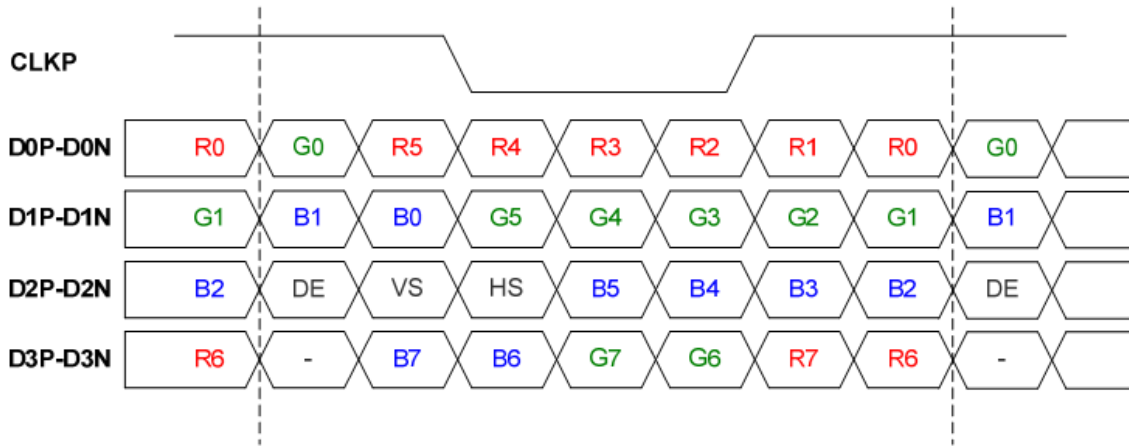

Note 1 : for 6 bit mode, MSB are R/G/B[5] and R/G/B[0] are LSB  
 Note 2 : for 8 bit mode, MSB are R/G/B[7] and R/G/B[0] are LSB

Figure 5.4. VESA Data Input timing

5.5 Power On/Off Timing

To prevent the device damage from latch up, the power on/off sequence shown below must be followed.

Power ON:

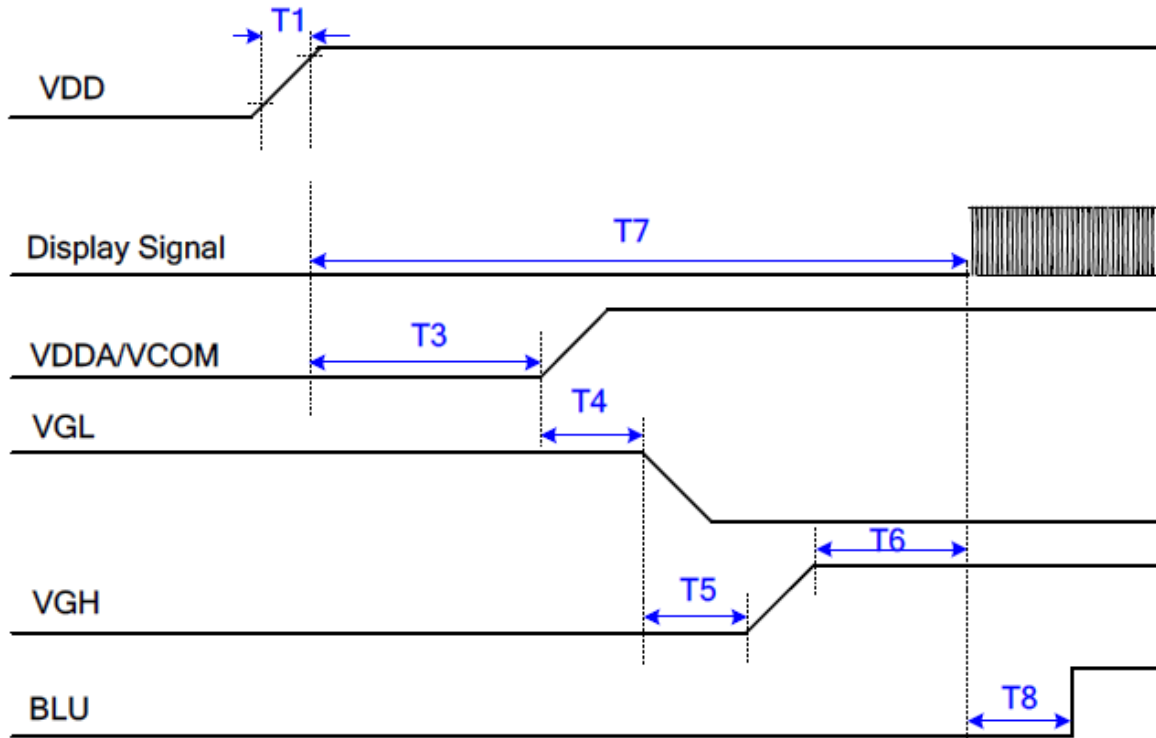

|    |                             |  |  |
|----|-----------------------------|--|--|
| T1 | $1.5ms \leq T1 \leq 3ms$    | VDD power on slew rate (0.1 ~ 0.9*VDD) |  |
| T3 | $10\ ms \leq T3 \leq 35ms$  | VDD (0.9*VDD) ~ AVDD                   |  |
| T4 | $T4 > 0ms$                  | AVDD ~ VGL                             |  |
| T5 | $T5 > 0ms$                  | VGL ~ VGH                              |  |
| T6 | $T6 > 5ms$                  | VGH(stable) ~ Signal                   |  |
| T7 | $10\ ms \leq T7 \leq 100ms$ | VDD (0.9*VDD) ~ Signal                 |  |
| T8 | $T8 > 10\ frames$           | Signal ~ BLU turn on                   |  |

Figure 5.5.1 Power On Timing

Power Off:

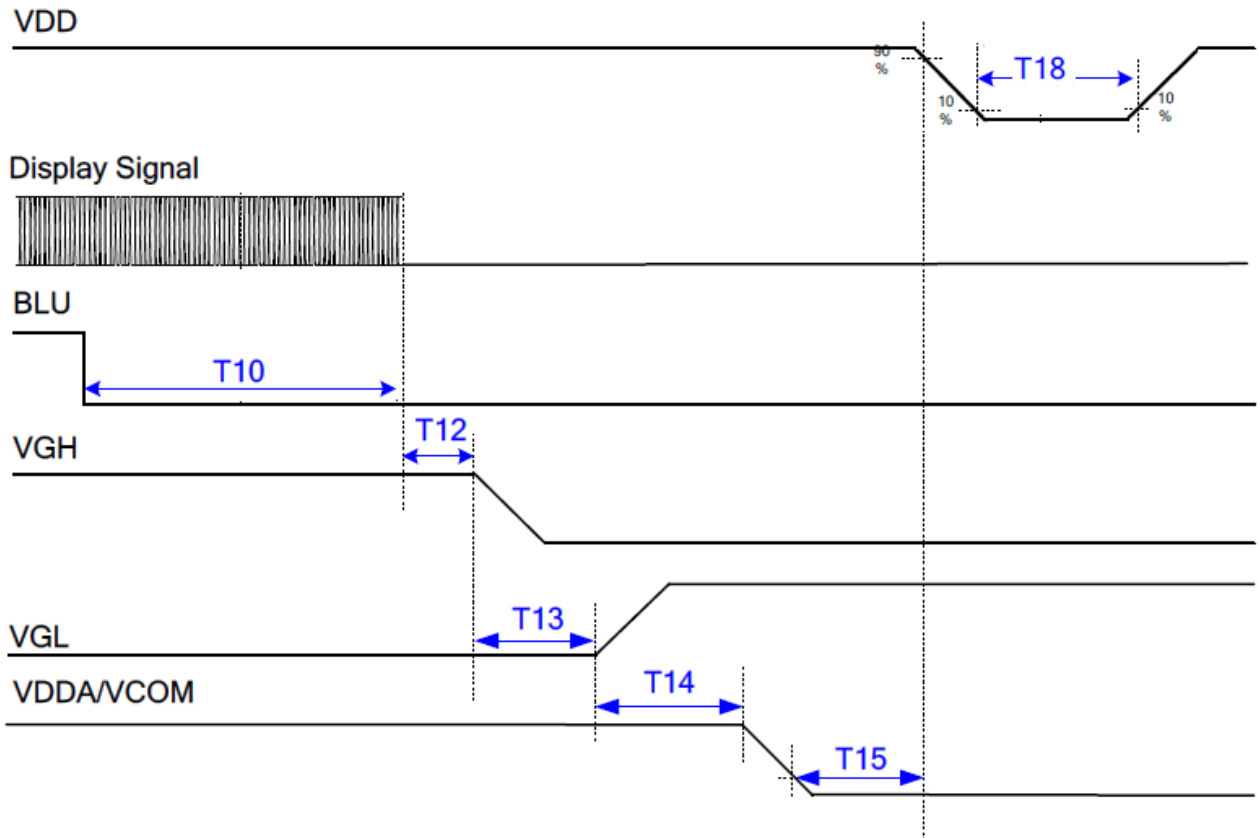

|     |                         |                                 |  |
|-----|-------------------------|---------------------------------|--|
| T10 | $T10 > 0\text{ms}$      | BLU turn off ~ Signal           |  |
| T12 | $T12 > 0\text{ms}$      | Signal ~ VGH                    |  |
| T13 | $T13 > 0\text{ms}$      | VGH ~ VGL                       |  |
| T14 | $T14 > 0\text{ms}$      | VGL ~ AVDD                      |  |
| T15 | $T15 \geq 1\text{ms}$   | AVDD (0.1*AVDD) ~ VDD (0.9*VDD) |  |
| T18 | $T18 \geq 200\text{ms}$ | All power off to next power on  | All power should be turn off to under 10% before T18 |

Figure 5.5.2 Power Off Timing

## 6. Optical Characteristics

| Item           | Symbol     | Condition          | Min   | Typ   | Max   | Unit              | Remark                                       |
|----------------|------------|--------------------|-------|-------|-------|-------------------|--|
| View Angles    | $\theta T$ | $CR \geq 10$       | 80    | 88    | -     | Degree            | Note 2                                       |
|                | $\theta B$ |                    | 80    | 88    | -     |                   |  |
|                | $\theta L$ |                    | 80    | 88    | -     |                   |  |
|                | $\theta R$ |                    | 80    | 88    | -     |                   |  |
| Contrast Ratio | CR         | $\theta = 0^\circ$ | 600   | 800   | -     |                   | Left/right $0^\circ$<br>Top/bottom $5^\circ$ |
| Response Time  | $T_{ON}$   | $25^\circ C$       | -     | 35    | 40    | ms                | Note1<br>Note4                               |
|                | $T_{OFF}$  |                    |       |       |       |                   |  |
| Chromaticity   | White      | x                  | 0.256 | 0.306 | 0.356 |                   | Note5<br>Note1                               |
|                |            | y                  | 0.279 | 0.329 | 0.379 |                   |  |
|                | Red        | x                  | 0.520 | 0.570 | 0.620 |                   |  |
|                |            | y                  | 0.280 | 0.330 | 0.380 |                   |  |
|                | Green      | x                  | 0.300 | 0.350 | 0.400 |                   |  |
|                |            | y                  | 0.542 | 0.592 | 0.642 |                   |  |
|                | Blue       | x                  | 0.105 | 0.155 | 0.205 |                   |  |
|                |            | y                  | 0.051 | 0.101 | 0.151 |                   |  |
| Uniformity     | U          |                    | 70    | 75    | -     | %                 | Note1、 Note6                                 |
| NTSC           |            |                    | 45    | 50    | -     | %                 |  |
| Luminance      | L          |                    | 320   | 400   | -     | cd/m <sup>2</sup> | Note7  |

Test Conditions:

- $I_F = 20mA$ (one channel), the ambient temperature is  $25^\circ C$ .
- The test systems refer to Note 1 and Note 2.



Note 1: Definition of optical measurement system.

The optical characteristics should be measured in dark room. After 10 Minutes operation, the optical properties are measured at the center point of the LCD screen. All input terminals LCD panel must be ground when measuring the center area of the panel.

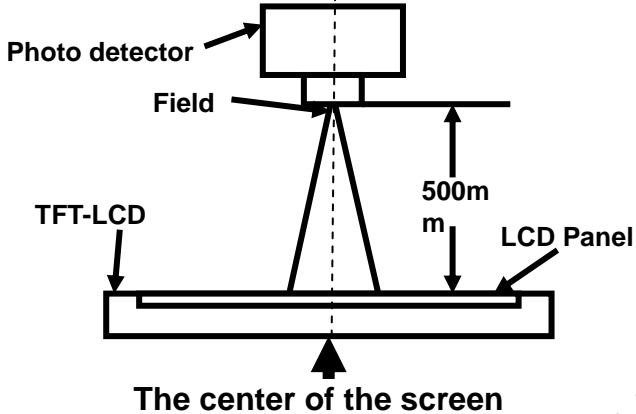

| Item           | Photo detector | Field |
|----------------|----------------|-------|
| Contrast Ratio | SR-3A          | 1°    |
| Luminance      |                |       |
| Chromaticity   |                |       |
| Lum Uniformity |                |       |
| Response Time  | BM-7A          | 2°    |

Note 2: Definition of viewing angle range and measurement system.

viewing angle is measured at the center point of the LCD by CONOSCOPE(ergo-80).

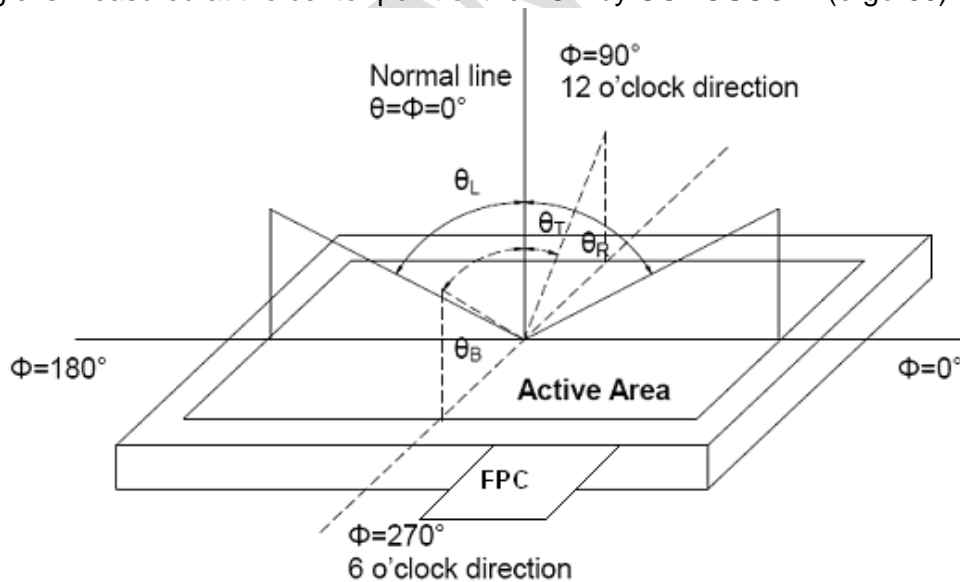

Note 3: Definition of contrast ratio

$$\text{Contrast ratio (CR)} = \frac{\text{Luminance measured when LCD is on the "White" state}}{\text{Luminance measured when LCD is on the "Black" state}}$$

“White state “: The state is that the LCD should drive by V<sub>white</sub>.

“Black state”: The state is that the LCD should drive by V<sub>black</sub>.

V<sub>white</sub>: To be determined    V<sub>black</sub>: To be determined.

Note 4: Definition of Response time

The response time is defined as the LCD optical switching time interval between “White” state and “Black” state. Rise time (T<sub>ON</sub>) is the time between photo detector output intensity changed from 90% to 10%. And fall time (T<sub>OFF</sub>) is the time between photo detector output intensity changed from 10% to 90%.

The information contained herein is the exclusive property of TIANMA MICRO-ELECTRONICS Corporation, and shall not be distributed, reproduced, or disclosed in whole or in part without prior written permission of TIANMA MICRO-ELECTRONICS Corporation.

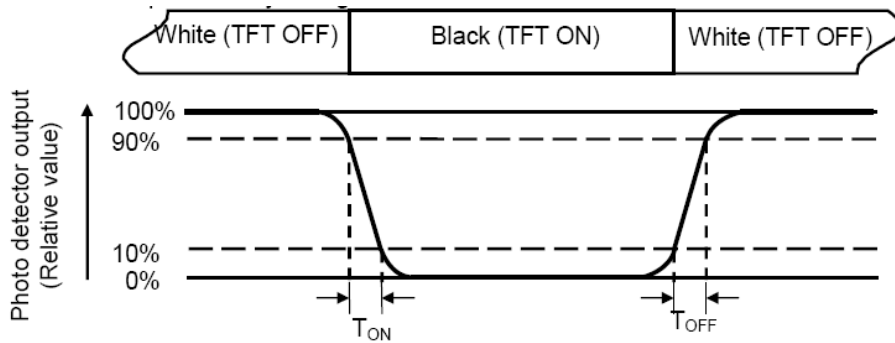

Note 5: Definition of color chromaticity (CIE1931)  
 Color coordinates measured at center point of LCD.

Note 6: Definition of Luminance Uniformity

Active area is divided into 9 measuring areas (Refer Fig. 2). Every measuring point is placed at the center of each measuring area.

$$\text{Luminance Uniformity (U)} = L_{\min} / L_{\max}$$

L-----Active area length W----- Active area width

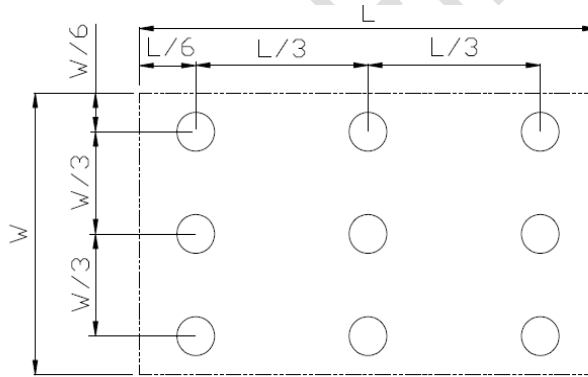

$L_{\max}$ : The measured Maximum luminance of all measurement position.

$L_{\min}$ : The measured Minimum luminance of all measurement position.

Note 7: Definition of Luminance:

Measure the luminance of white state at center point.

## 7. Reliability Test

| No | Test Item                                | Condition  | Remarks   |
|----|--|--|---|
| 1  | High Temperature Operation               | Ta = +70°C, 240 hours  | IEC60068-2-1:2007<br>GB2423.2-2008  |
| 2  | Low Temperature Operation                | Ta = -20°C, 240 hours  | IEC60068-2-1:2007<br>GB2423.1-2008  |
| 3  | High Temperature Storage                 | Ta = +80°C, 240 hours  | IEC60068-2-1:2007<br>GB2423.2-2008  |
| 4  | Low Temperature Storage                  | Ta = -30°C, 240 hours  | IEC60068-2-1:2007<br>GB2423.1-2008  |
| 5  | Operate at High Temperature and Humidity | Ta=+60°C、RH=90%, 240 hours   | IEC60068-2-78 :2001<br>GB/T2423.3—2006  |
| 6  | Thermal Shock (non-operation)            | -30°C (30min) ⇔ 80°C (30min) ,Change Time:5min,20cycle   | Start with cold temperature,<br>End with high temperature,<br>IEC60068-2-14:1984,G<br>B2423.22-2002 |
| 7  | ESD                                      | C=150pF、R=330Ω<br>Air: ±8KV Contact:±4KV<br>5point/panel, 5times<br>(Environment:15°C~35°C,<br>30%~60%.86Kpa~106Kpa)             | IEC61000-4-2:2001<br>GB/T17626.2-2006   |
| 8  | Vibration Test                           | Frequency range:10~55Hz<br>Stroke: 1.5mm<br>Sweep: 10Hz~55Hz~10Hz<br>2 hours for each direction of X.Y.Z.<br>(6 hours for total) | IEC60068-2-6:1982<br>GB/T2423.10—1995   |
| 9  | Mechanical Shock (Non OP)                | Half Sine Wave<br>60G ,6ms,±X,±Y,±Z<br>3times for each direction   | IEC60068-2-27:1987<br>GB/T2423.5—1995   |
| 10 | Package Drop Test                        | Height:60cm,<br>1corner,3edges,6surfaces   | IEC60068-2-32:1990<br>GB/T2423.8—1995   |

### Notes:

1. The test result shall be evaluated after the sample has been left at room temperature and humidity for 2 hours without load. No condensation shall be accepted. The sample will not be accepted if appear these defects:

- 1).Air bubble in the LCD;
- 2).Seal leak
- 3).Non-display
- 4).missing segments
- 5).Glass crack

The information contained herein is the exclusive property of TIANMA MICRO-ELECTRONICS Corporation, and shall not be distributed, reproduced, or disclosed in whole or in part without prior written permission of TIANMA MICRO-ELECTRONICS Corporation.

- 6).CR reduction >40%
  - 7).IDD increase >100%
  - 8).Brightness reduction >50%
  - 9).Color coordinate tolerance >0.05
3. Each test item applies for a test sample only once, The test sample can not be used again in any other test item.
- 4.For Damp Proof Test, Pure water(Resistance > 10MΩ) should be used.
- 5.In case of malfunction defect caused by ESD damage, if it would be recovered to normal state after resetting, it would be judge as a good part.
- 6 In the test of High Temperature Operation and High Temperature & Humidity Operation ,the operation temperature is the surface temperature of module
- 7 High Temperature Operation、 Low Temperature Operation、 High Temperature Storage、 Low Temperature Storage、 High Temperature & Humidity Operation、 High Temperature & Humidity Storage will be increased the test time to 1000hours in the same conditions to test out the ability of module, and we can not guarantee that the module will not fail during 1000hours.These items test only once

### 8. Mechanical Drawing

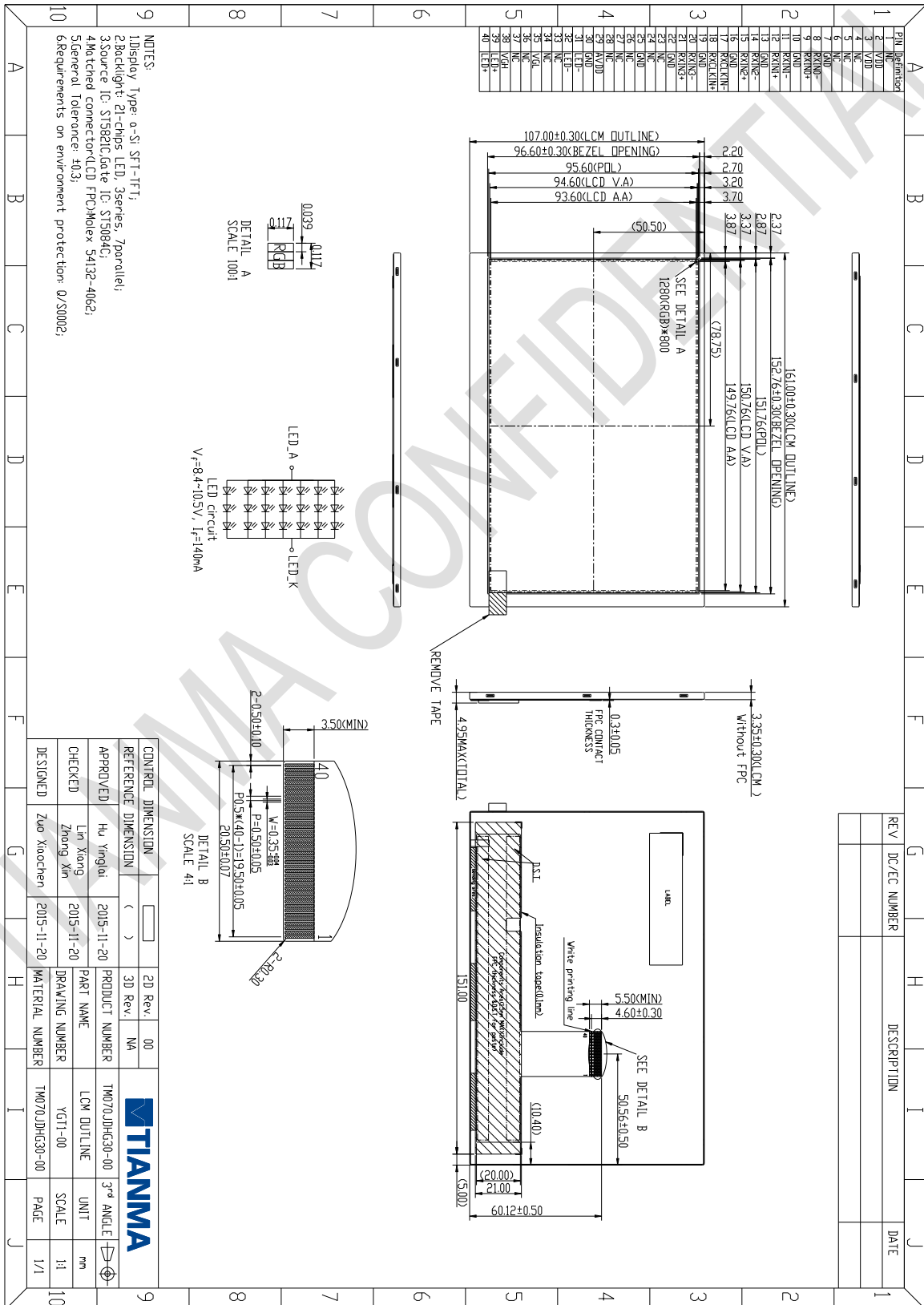

The information contained herein is the exclusive property of TIANMA MICRO-ELECTRONICS Corporation, and shall not be distributed, reproduced, or disclosed in whole or in part without prior written permission of TIANMA MICRO-ELECTRONICS Corporation.

### 9. Packing Drawing

| No | Item         | Model (Materiel) | Dimensions(mm)   | Unit Weight(Kg) | Quantity | Remark |  |
|----|--------------|------------------|------------------|-----------------|----------|--------|--|
| 1  | LCM 模组       | TM070JDHG30-00   | 161.0x107.0x3.35 | ---             | 72       |        |  |
| 2  | Tray 吸塑盘     | PET              | 485x330x15.3     | 0.167           | 21       |        |  |
| 3  | BOX 纸盒       | CORRUGATED PAPER | 520x345x74       | 0.44            | 3        |        |  |
| 4  | 防尘袋          | LD-PE            | 700x545x0.05     | 0.046           | 1        |        |  |
| 5  | Lable 标签     | tagboard         | 100x52           | 0.002           | 1        |        |  |
| 6  | Carton 纸箱    | CORRUGATED PAPER | 544x365x250      | 1.01            | 1        |        |  |
| 7  | Total Weight | TBD ±5% kg       |                  |                 |          |        |  |

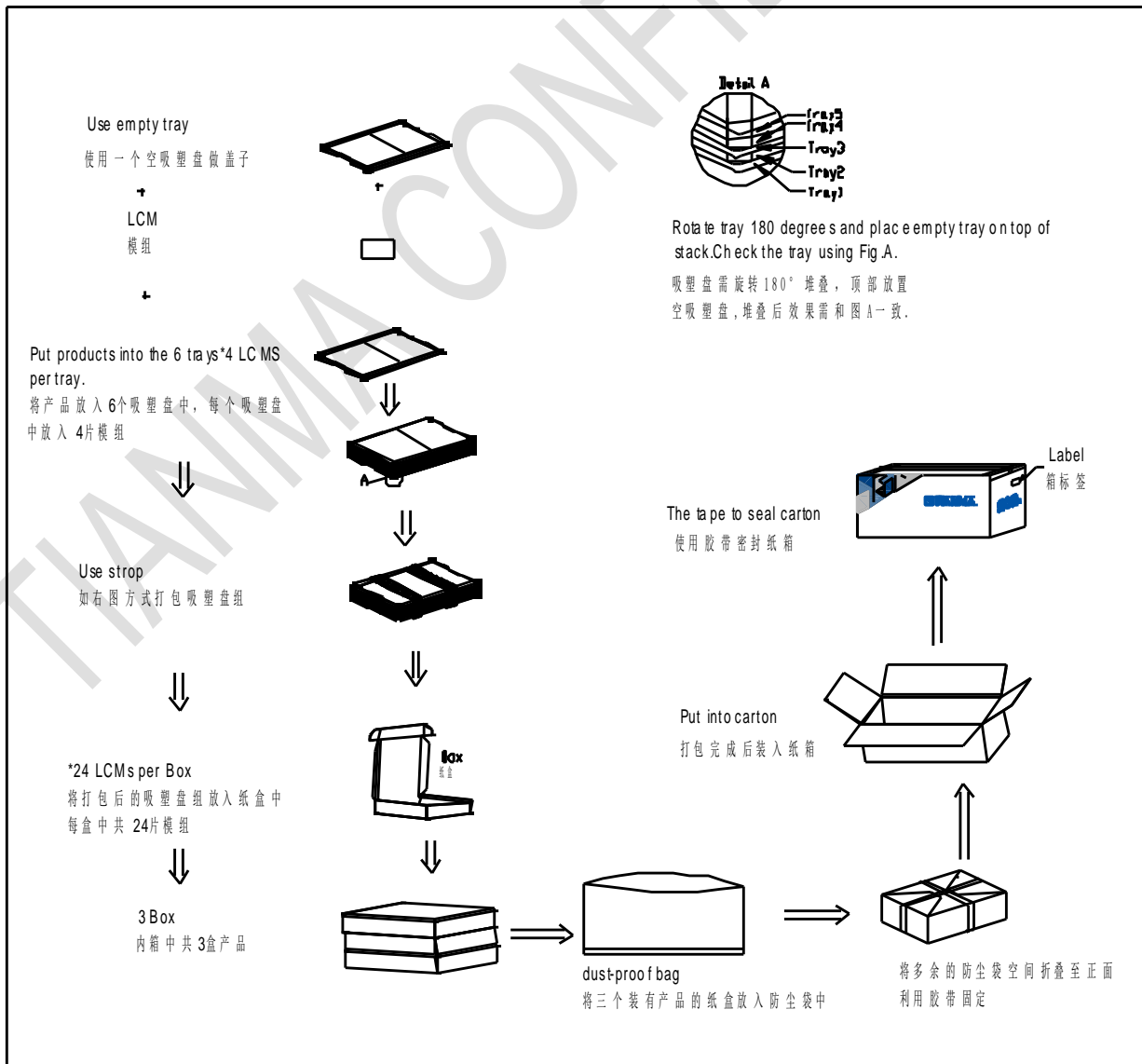

The information contained herein is the exclusive property of TIANMA MICRO-ELECTRONICS Corporation, and shall not be distributed, reproduced, or disclosed in whole or in part without prior written permission of TIANMA MICRO-ELECTRONICS Corporation.

## 10. Precautions for Use of LCD Modules

### 10.1 Handling Precautions

- 10.1.1 The display panel is made of glass. Do not subject it to a mechanical shock by dropping it from a high place, etc.
- 10.1.2 If the display panel is damaged and the liquid crystal substance inside it leaks out, be sure not to get any in your mouth, if the substance comes into contact with your skin or clothes, promptly wash it off using soap and water.
- 10.1.3 Do not apply excessive force to the display surface or the adjoining areas since this may cause the color tone to vary.
- 10.1.4 The polarizer covering the display surface of the LCD module is soft and easily scratched. Handle this polarizer carefully.
- 10.1.5 If the display surface is contaminated, breathe on the surface and gently wipe it with a soft dry cloth. If still not completely clear, moisten cloth with one of the following solvents:
- Isopropyl alcohol
  - Ethyl alcohol
- Solvents other than those mentioned above may damage the polarizer.  
Especially, do not use the following:
- Water
  - Ketone
  - Aromatic solvents
- 10.1.6 Do not attempt to disassemble the LCD Module.
- 10.1.7 If the logic circuit power is off, do not apply the input signals.
- 10.1.8 To prevent destruction of the elements by static electricity, be careful to maintain an optimum work environment.
- a. Be sure to ground the body when handling the LCD Modules.
  - b. Tools required for assembly, such as soldering irons, must be properly ground.
  - c. To reduce the amount of static electricity generated, do not conduct assembly and other work under dry conditions.
  - d. The LCD Module is coated with a film to protect the display surface. Be care when peeling off this protective film since static electricity may be generated.

## 10.2 Storage precautions

10.2.1 When storing the LCD modules, avoid exposure to direct sunlight or to the light of fluorescent lamps.

10.2.2 The LCD modules should be stored under the storage temperature range. If the LCD modules will be stored for a long time, the recommend condition is:

Temperature :        0°C ~ 40°C

Relatively humidity: ≤80%

10.2.3 The LCD modules should be stored in the room without acid, alkali and harmful gas.

**10.3 The LCD modules should be no falling and violent shocking during transportation, and also should avoid excessive press, water, damp and sunshine.**