



Product Specification

G070VAN01.001

AU OPTRONICS CORPORATION

(v) Preliminary Specifications

() Final Specifications

Module	7 Inch Color TFT-LCD
Model Name	G070VAN01.0 (001)

Customer	Date
_____	_____
Checked & Approved by	Date
_____	_____
Customer's sign back page	

Approved by	Date
Grace Hung	2019/12/25
Prepared by	Date
Ivan Chao	2019/12/25
General Display Business Division / AU Optronics corporation	



Contents

1. Operating Precautions	4
2. General Description	5
2.1 Display Characteristics	5
2.2 Optical Characteristics	6
3. Functional Block Diagram	9
4. Absolute Maximum Ratings	10
4.1 Absolute Ratings of TFT LCD Module	10
4.2 Absolute Ratings of Environment	10
5. Electrical Characteristics	10
5.1 TFT LCD Module	10
5.2 Backlight Unit	13
6. Signal Characteristic	14
6.1 Pixel Format Image	14
6.2 Signal Description	15
6.3 The Input Data Format	16
6.4 Interface Timing	18
6.5 Power ON/OFF Sequence	19
7. Reliability Test Criteria	21
8. Mechanical Characteristics	22
8.1 LCM Outline Dimension	22
9. Label and Packaging	23
9.1 Shipping Label (on the rear side of TFT-LCD display)	23
9.2 Carton Package	23
10 Safety	24
10.1 Sharp Edge Requirements	24
10.2 Materials	24
10.3 Capacitors	24
10.4 National Test Lab Requirement	24

Record of Revision

Version	Date (yyyy/m/d)	Page	Old description	New Description																																																																		
0.1	2019/12/02	All	First draft specification																																																																			
0.2	2019/12/13	6	<table border="1"> <thead> <tr> <th>Item</th> <th>Unit</th> <th>Conditions</th> <th>Min.</th> <th>Typ.</th> <th>Max.</th> <th>Note</th> </tr> </thead> <tbody> <tr> <td>White Luminance</td> <td>cd/m²</td> <td>L₅₀=92mA(center point)</td> <td>-</td> <td>400</td> <td>-</td> <td>1</td> </tr> </tbody> </table>	Item	Unit	Conditions	Min.	Typ.	Max.	Note	White Luminance	cd/m ²	L ₅₀ =92mA(center point)	-	400	-	1	<table border="1"> <thead> <tr> <th>Item</th> <th>Unit</th> <th>Conditions</th> <th>Min.</th> <th>Typ.</th> </tr> </thead> <tbody> <tr> <td>White Luminance</td> <td>cd/m²</td> <td>L₅₀=92mA(center point)</td> <td>380</td> <td>480</td> </tr> </tbody> </table>	Item	Unit	Conditions	Min.	Typ.	White Luminance	cd/m ²	L ₅₀ =92mA(center point)	380	480																																										
Item	Unit	Conditions	Min.	Typ.	Max.	Note																																																																
White Luminance	cd/m ²	L ₅₀ =92mA(center point)	-	400	-	1																																																																
Item	Unit	Conditions	Min.	Typ.																																																																		
White Luminance	cd/m ²	L ₅₀ =92mA(center point)	380	480																																																																		
0.3	2019/12/25	23																																																																				
		24																																																																				
		21	<table border="1"> <thead> <tr> <th>Items</th> <th>Required Condition</th> <th>Note</th> </tr> </thead> <tbody> <tr> <td>Temperature Humidity Bias</td> <td>60°C/90%,504Hr</td> <td>-</td> </tr> <tr> <td>High Temperature Operation</td> <td>70°C, 504Hr</td> <td>-</td> </tr> <tr> <td>Low Temperature Operation</td> <td>-20°C, 504Hr</td> <td>-</td> </tr> <tr> <td>Hot Storage</td> <td>80°C, 504 hours</td> <td>-</td> </tr> <tr> <td>Cold Storage</td> <td>-30°C, 504 hours</td> <td>-</td> </tr> <tr> <td>Thermal Shock Test</td> <td>-30°C ~ 80°C /100 cycles 0.5Hr/cycle</td> <td>-</td> </tr> <tr> <td>Shock Test (Non-Operating)</td> <td>50G,20ms,Half-sine wave,(+X,+Y,+Z)</td> <td>-</td> </tr> <tr> <td>Vibration Test (Non-Operating)</td> <td>Frequency: 10~55Hz Stroke: 1.5mm Sweep: 10~55~10Hz</td> <td>-</td> </tr> <tr> <td>ESD</td> <td>Contact: ± 8KV / operation, Class B Air: ± 15KV / operation, Class B</td> <td>Note 1</td> </tr> <tr> <td>Drop (with carton)</td> <td>Height: 61cm 1 corner, 3 edges, 6 surfaces</td> <td>-</td> </tr> </tbody> </table>	Items	Required Condition	Note	Temperature Humidity Bias	60°C/90%,504Hr	-	High Temperature Operation	70°C, 504Hr	-	Low Temperature Operation	-20°C, 504Hr	-	Hot Storage	80°C, 504 hours	-	Cold Storage	-30°C, 504 hours	-	Thermal Shock Test	-30°C ~ 80°C /100 cycles 0.5Hr/cycle	-	Shock Test (Non-Operating)	50G,20ms,Half-sine wave,(+X,+Y,+Z)	-	Vibration Test (Non-Operating)	Frequency: 10~55Hz Stroke: 1.5mm Sweep: 10~55~10Hz	-	ESD	Contact: ± 8KV / operation, Class B Air: ± 15KV / operation, Class B	Note 1	Drop (with carton)	Height: 61cm 1 corner, 3 edges, 6 surfaces	-	<table border="1"> <thead> <tr> <th>Items</th> <th>Required Condition</th> <th>Note</th> </tr> </thead> <tbody> <tr> <td>Temperature Humidity Bias</td> <td>60°C/90%,300Hr</td> <td>-</td> </tr> <tr> <td>High Temperature Operation</td> <td>80°C, 300Hr</td> <td>-</td> </tr> <tr> <td>Low Temperature Operation</td> <td>-30°C, 300Hr</td> <td>-</td> </tr> <tr> <td>Hot Storage</td> <td>80°C, 300 hours</td> <td>-</td> </tr> <tr> <td>Cold Storage</td> <td>-30°C, 300 hours</td> <td>-</td> </tr> <tr> <td>Thermal Shock Test</td> <td>-30°C ~ 80°C /100 cycles 0.6Hr/cycle</td> <td>-</td> </tr> <tr> <td>Shock Test (Non-Operating)</td> <td>60G,20ms,Half-sine wave,(+X,+Y,+Z)</td> <td>-</td> </tr> <tr> <td>Vibration Test (Non-Operating)</td> <td>Frequency: 10~55Hz Stroke: 1.6mm Sweep: 10~55~10Hz</td> <td>-</td> </tr> <tr> <td>ESD</td> <td>Contact: ± 8KV / operation, Class B Air: ± 15KV / operation, Class B</td> <td>Note 1</td> </tr> <tr> <td>Drop (with carton)</td> <td>Height: 61cm 1 corner, 3 edges, 6 surfaces</td> <td>-</td> </tr> </tbody> </table>	Items	Required Condition	Note	Temperature Humidity Bias	60°C/90%,300Hr	-	High Temperature Operation	80°C, 300Hr	-	Low Temperature Operation	-30°C, 300Hr	-	Hot Storage	80°C, 300 hours	-	Cold Storage	-30°C, 300 hours	-	Thermal Shock Test	-30°C ~ 80°C /100 cycles 0.6Hr/cycle	-	Shock Test (Non-Operating)	60G,20ms,Half-sine wave,(+X,+Y,+Z)	-	Vibration Test (Non-Operating)	Frequency: 10~55Hz Stroke: 1.6mm Sweep: 10~55~10Hz	-	ESD	Contact: ± 8KV / operation, Class B Air: ± 15KV / operation, Class B	Note 1	Drop (with carton)	Height: 61cm 1 corner, 3 edges, 6 surfaces	-
Items	Required Condition	Note																																																																				
Temperature Humidity Bias	60°C/90%,504Hr	-																																																																				
High Temperature Operation	70°C, 504Hr	-																																																																				
Low Temperature Operation	-20°C, 504Hr	-																																																																				
Hot Storage	80°C, 504 hours	-																																																																				
Cold Storage	-30°C, 504 hours	-																																																																				
Thermal Shock Test	-30°C ~ 80°C /100 cycles 0.5Hr/cycle	-																																																																				
Shock Test (Non-Operating)	50G,20ms,Half-sine wave,(+X,+Y,+Z)	-																																																																				
Vibration Test (Non-Operating)	Frequency: 10~55Hz Stroke: 1.5mm Sweep: 10~55~10Hz	-																																																																				
ESD	Contact: ± 8KV / operation, Class B Air: ± 15KV / operation, Class B	Note 1																																																																				
Drop (with carton)	Height: 61cm 1 corner, 3 edges, 6 surfaces	-																																																																				
Items	Required Condition	Note																																																																				
Temperature Humidity Bias	60°C/90%,300Hr	-																																																																				
High Temperature Operation	80°C, 300Hr	-																																																																				
Low Temperature Operation	-30°C, 300Hr	-																																																																				
Hot Storage	80°C, 300 hours	-																																																																				
Cold Storage	-30°C, 300 hours	-																																																																				
Thermal Shock Test	-30°C ~ 80°C /100 cycles 0.6Hr/cycle	-																																																																				
Shock Test (Non-Operating)	60G,20ms,Half-sine wave,(+X,+Y,+Z)	-																																																																				
Vibration Test (Non-Operating)	Frequency: 10~55Hz Stroke: 1.6mm Sweep: 10~55~10Hz	-																																																																				
ESD	Contact: ± 8KV / operation, Class B Air: ± 15KV / operation, Class B	Note 1																																																																				
Drop (with carton)	Height: 61cm 1 corner, 3 edges, 6 surfaces	-																																																																				



1. Operating Precautions

- 1) Since front polarizer is easily damaged, please be cautious and not to scratch it.
- 2) Be sure to turn off power supply when inserting or disconnecting from input connector.
- 3) Wipe off water drop immediately. Long contact with water may cause discoloration or spots.
- 4) When the panel surface is soiled, wipe it with absorbent cotton or soft cloth.
- 5) Since the panel is made of glass, it may be broken or cracked if dropped or bumped on hard surface.
- 6) To avoid ESD (Electro Static Discharge) damage, be sure to ground yourself before handling TFT-LCD Module.
- 7) Do not open nor modify the module assembly.
- 8) Do not press the reflector sheet at the back of the module to any direction.
- 9) In case if a module has to be put back into the packing container slot after it was taken out from the container, do not press the center of the LED light bar edge. Instead, press at the far ends of the LED light bar edge softly. Otherwise the TFT Module may be damaged.
- 10) At the insertion or removal of the Signal Interface Connector, be sure not to rotate nor tilt the Interface Connector of the TFT Module.
- 11) TFT-LCD Module is not allowed to be twisted & bent even force is added on module in a very short time. Please design your display product well to avoid external force applying to module by end-user directly.
- 12) Small amount of materials having no flammability grade is used in the LCD module. The LCD module should be supplied by power complied with requirements of Limited Power Source (IEC60950 or UL1950), or be applied exemption.
- 13) Severe temperature condition may result in different luminance, response time and lamp ignition voltage.
- 14) Continuous operating TFT-LCD display under low temperature environment may accelerate lamp exhaustion and reduce luminance dramatically.
- 15) The data on this specification sheet is applicable when LCD module is placed in landscape position.
- 16) Continuous displaying fixed pattern may induce image sticking. It's recommended to use screen saver or shuffle content periodically if fixed pattern is displayed on the screen.



2. General Description

G070VAN01.0 is an a-Si & transmissive type thin film transistor liquid crystal display (TFT-LCD) with AHVA (Advanced Hyper View Angle) technology. This model is composed of a TFT-LCD, a driver, an FPCA (flexible printed circuit assembly), and a backlight unit.

2.1 Display Characteristics

The following items are characteristics summary on the table under 25 °C condition:

Items	Unit	Specifications
Screen Diagonal	[inch]	7.0
Active Area	[mm]	152.4(H)×91.44(V)
Resolution		800 (H)×480 RGB(V)
Pixel Pitch	[mm]	0.1905(H)x0.0635xRGB(V)
Pixel Arrangement		R. G. B. Horizontal Stripe
Display Mode		Normally Black
Nominal Input Voltage VDD	[Volt]	3.3 (typ.)
Power Consumption	[Watt]	2.978 (max.)
Weight	[Grams]	175±10%
Physical Size	[mm]	166.6(H) × 107(V) × 10(T)(Max.)
Electrical Interface		LVDS
Surface Treatment		Anti-Glare,
Support Color		16.7M Colors
Temperature Range		
Operating	[°C]	-30 ~ +80
Storage (Non-Operating)	[°C]	-30 ~ +80
RoHS Compliance		Yes

2.2 Optical Characteristics

The optical characteristics are measured under stable conditions at 25 °C (Room Temperature):

Item	Unit	Conditions	Min.	Typ.	Max.	Note
White Luminance	cd/m ²	I _{LED} =92mA(center point)	380	480		1
Uniformity	%	9 points		80		2,3
Contrast Ratio	--		1000	1300		4
Response Time	msec	Rising			11	5
		Falling			19	
		Rising + Falling			20	
Viewing Angle	degree	Horizontal CR >= 10	(Right)	70	89	6
			(Left)	70	89	
		Vertical CR >= 10	(Upper)	70	89	
			(Lower)	70	89	
Color / Chromaticity Coordinates (CIE 1931)	--	Red x	0.593	0.643	0.693	
		Red y	0.283	0.333	0.383	
		Green x	0.255	0.305	0.355	
		Green y	0.563	0.613	0.663	
		Blue x	0.105	0.155	0.205	
		Blue y	0.001	0.051	0.101	
		White x	0.257	0.307	0.357	
		White y	0.271	0.321	0.371	
Color Gamut	%			70		

Note 1: Measurement method

Equipment Pattern Generator, Power Supply, Digital Voltmeter, Luminance meter (SR_3 or equivalent)

Aperture 1□with 50cm viewing distance

Test Point Center

Environment < 1 lux

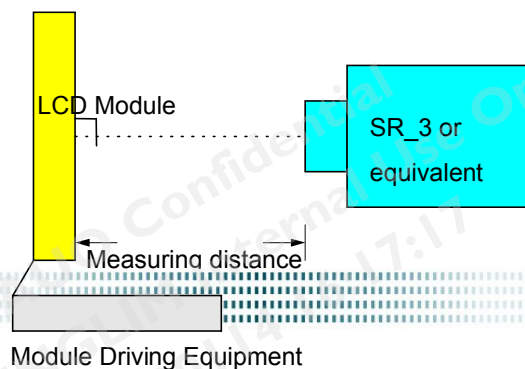

Note 2: Definition of 9 points position

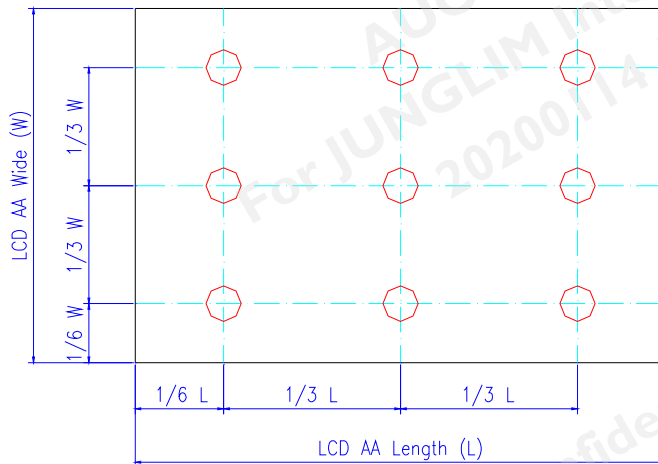

Note 3: The luminance uniformity of 9 points is defined by dividing the minimum luminance values by the maximum test point luminance

$$\delta_{w9} = \frac{\text{Minimum Brightness of nine points}}{\text{Maximum Brightness of nine points}}$$

Note 4: Definition of contrast ratio (CR):

$$\text{Contrast ratio (CR)} = \frac{\text{Brightness on the "White" state}}{\text{Brightness on the "Black" state}}$$

Note 5: Definition of response time:

The output signals of photo detector are measured when the input signals are changed from "White" to "Black" (falling time) and from "Black" to "White" (rising time), respectively. The response time interval is between 10% and 90% of amplitudes. Please refer to the figure as below.

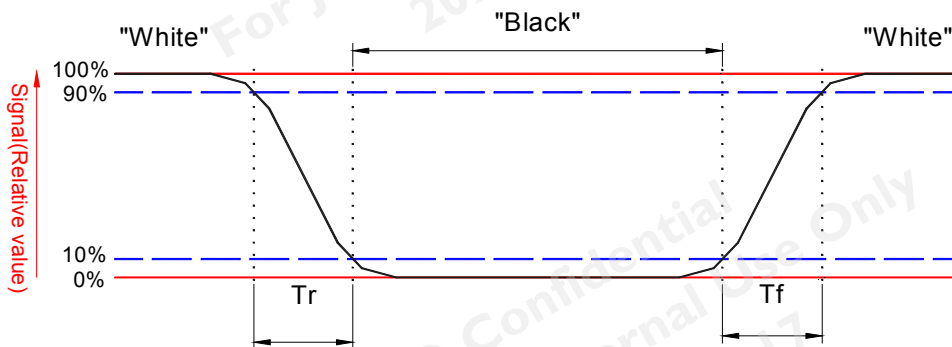

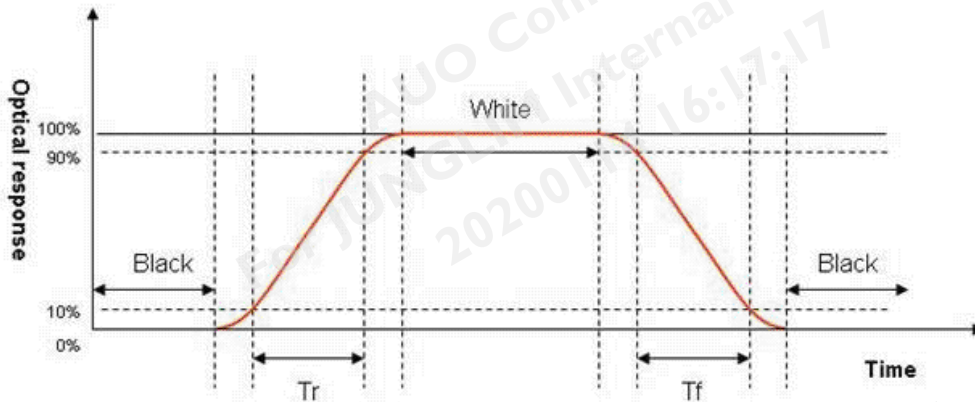

Note 6: Definition of viewing angle

Viewing angle is the measurement of contrast ratio ≥ 10 , at the screen center, over a 180° horizontal and 180° vertical range (off-normal viewing angles). The 180° viewing angle range is broken down as below: 90° (θ) horizontal left and right, and 90° (Φ) vertical high (up) and low (down). The measurement direction is typically perpendicular to the display surface with the screen rotated to its center to develop the desired measurement viewing angle.

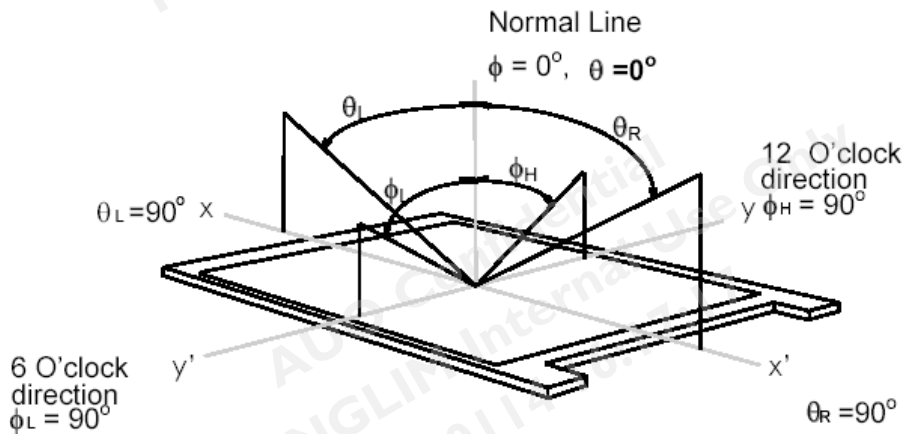

3. Functional Block Diagram

The following diagram shows the functional block of the 7 inch color TFT/LCD module:

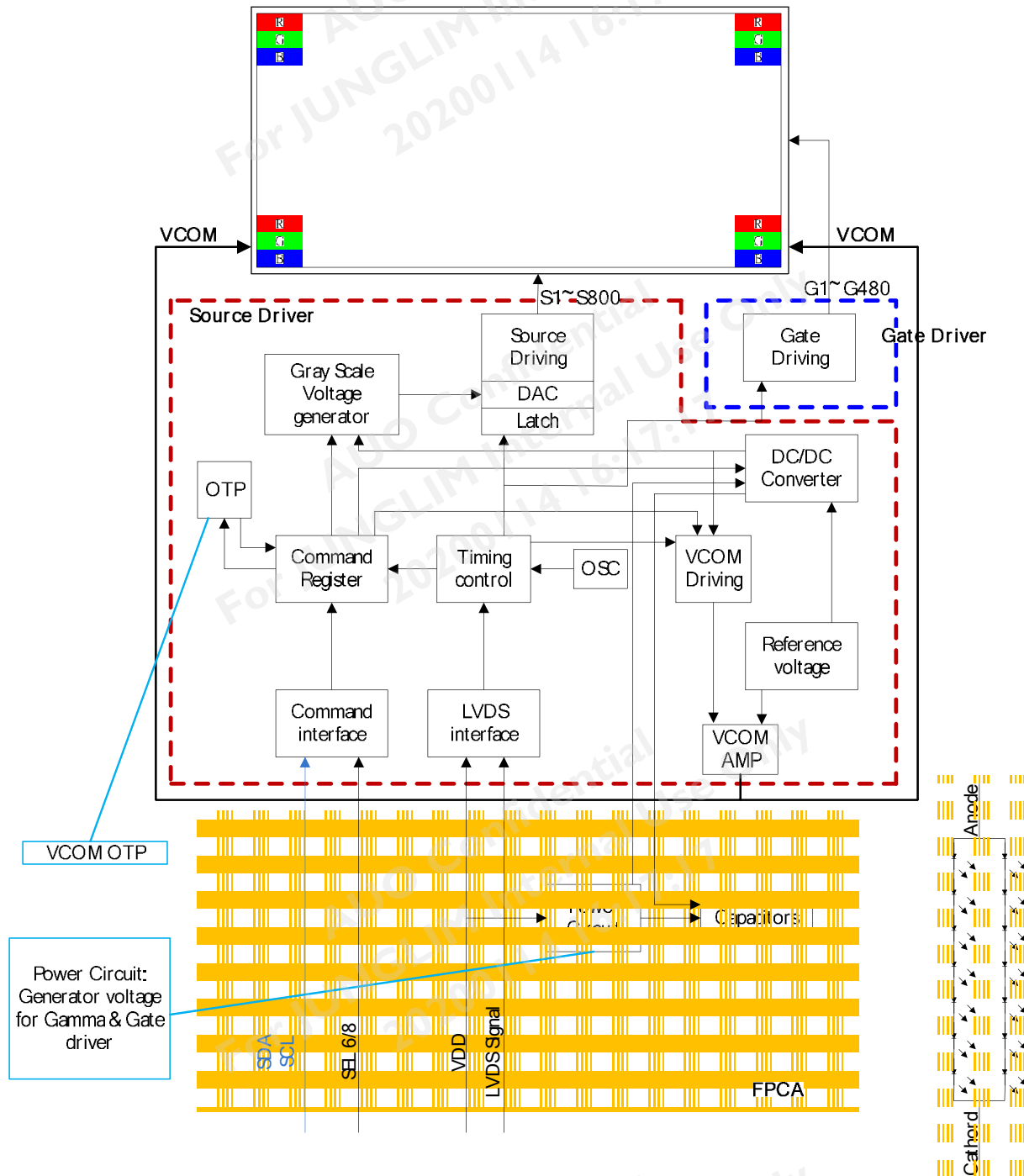

4. Absolute Maximum Ratings

4.1 Absolute Ratings of TFT LCD Module

Item	Symbol	Min	Max	Unit
Logic/LCD drive Voltage	Vin	-0.3	VDD+0.3	[Volt]

4.2 Absolute Ratings of Environment

Item	Symbol	Min	Max	Unit
Operating	TOP	-30	80	[°C]
Operation Humidity	HOP	5	90	[%RH]
Storage Temperature	TST	-30	80	[°C]
Storage Humidity	HST	5	90	[%RH]

Note: Maximum Wet-Bulb should be 39 °C and no condensation.

5. Electrical Characteristics

5.1 TFT LCD Module

5.1.1 Power Specification

Input power specifications are shown as follows;

Symbol	Parameter	Min	Typ	Max	Units	Remark
VDD	Logic/LCD Drive Voltage	3.0	3.3	3.6	[Volt]	Note1
IVDD	Panel Current	-	140	200	[mA]	Note1,2,3
IVDD Inrush	Inrush Current	-	-	550	[mA]	Note 2
Digital input	Leakage current	-	-	50	[uA]	Note 2
Differential input		-	-	100	[uA]	Note 2
IVDD		-	-	300	[uA]	Note 2

All conditions should be set typical value.

The panel can operate normally in the recommended operating condition.

Note1: Test pattern is the following picture & typ. By VDD=3.3V & max by VDD=3.6V



Product Specification

G070VAN01.001

AU OPTRONICS CORPORATION

Note2: Operating temperature from -20°C to 70°C

Note3: panel loading of color bar pattern is close to typ spec., VBW pattern is close to max spec.



Color bar pattern

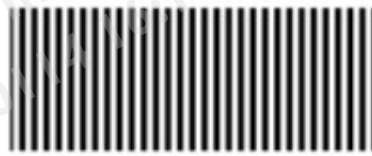

VBW pattern

AUO Confidential
For JUNGLIM Internal Use Only
20200114 16:17:17

AUO Confidential
For JUNGLIM Internal Use Only
20200114 16:17:17

AUO Confidential
For JUNGLIM Internal Use Only
20200114 16:17:17

5.1.2 LVDS DC Signal Electrical Characteristics

Symbol	Item	Min.	Typ.	Max.	Unit	Remark
VTH	Differential Input High Threshold	100	-	-	[mV]	VCM=1.2V
VTL	Differential Input Low Threshold	-	-	-100	[mV]	VCM=1.2V
VID	Input Differential Voltage	200	-	600	[mV]	
VICM	Differential Input Common Mode Voltage	1.0	1.2	1.4	[V]	VTH/VTL=+-100mV

Input signals shall be low or Hi-Z state when VDD is off.

Note: LVDS Signal Waveform.

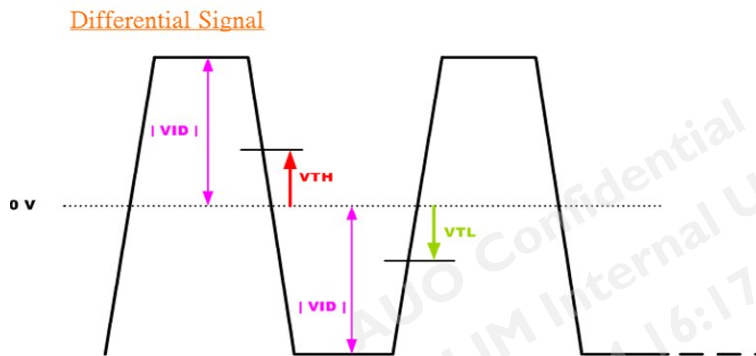
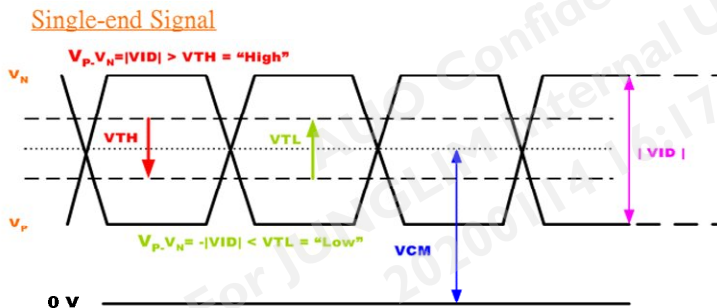

5.2 Backlight Unit

5.2.1 Parameter guideline for LED

Following characteristics are measured under a stable condition using an inverter at 25°C (Room Temperature):

Backlight driving conditions

Symbol	Parameter	Min.	Typ.	Max.	Unit	Remark
I_L	LED Supply Current	-	92		[mA]	Ta = 25°C, Note 2
V_L	LED Supply Voltage	-	22.4	25.2	[Volt]	Ta = 25°C Note 2/3
P_{LED}	LED Power Consumption		2.06		[Watt]	Ta = 25°C Note 3/4/5
L_L	LED Life Time	50000	70000		Hrs	Ta = 25°C, Note 6, Note 7

Note 1: Ta means ambient temperature of TFT-LCD module.

Note 2: I_L , V_L are defined for 2strings of LED

Note 3: LED backlight is 14 LEDs (2strings, 7pcs for each string)

Note 4: The LED supply power is for 2strings of LED

Note 5: The voltage capacity of LED driver IC must be over max. of LED Voltage.

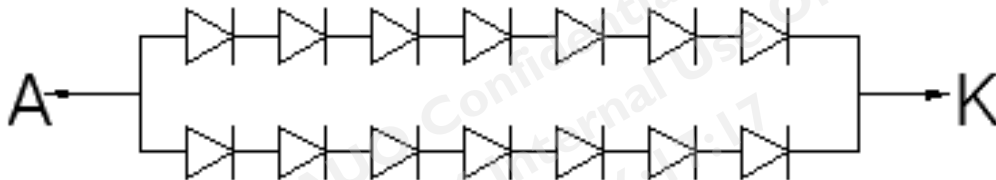

Note 6: Definition of life time: Brightness becomes to 50% of its original value.

Note 7: If G070VAN01.0 module is driven by high current or at high ambient temperature & humidity condition. The operating life will be reduced

6. Signal Characteristic

6.1 Pixel Format Image

Following figure shows the relationship between input signal and LCD pixel format.

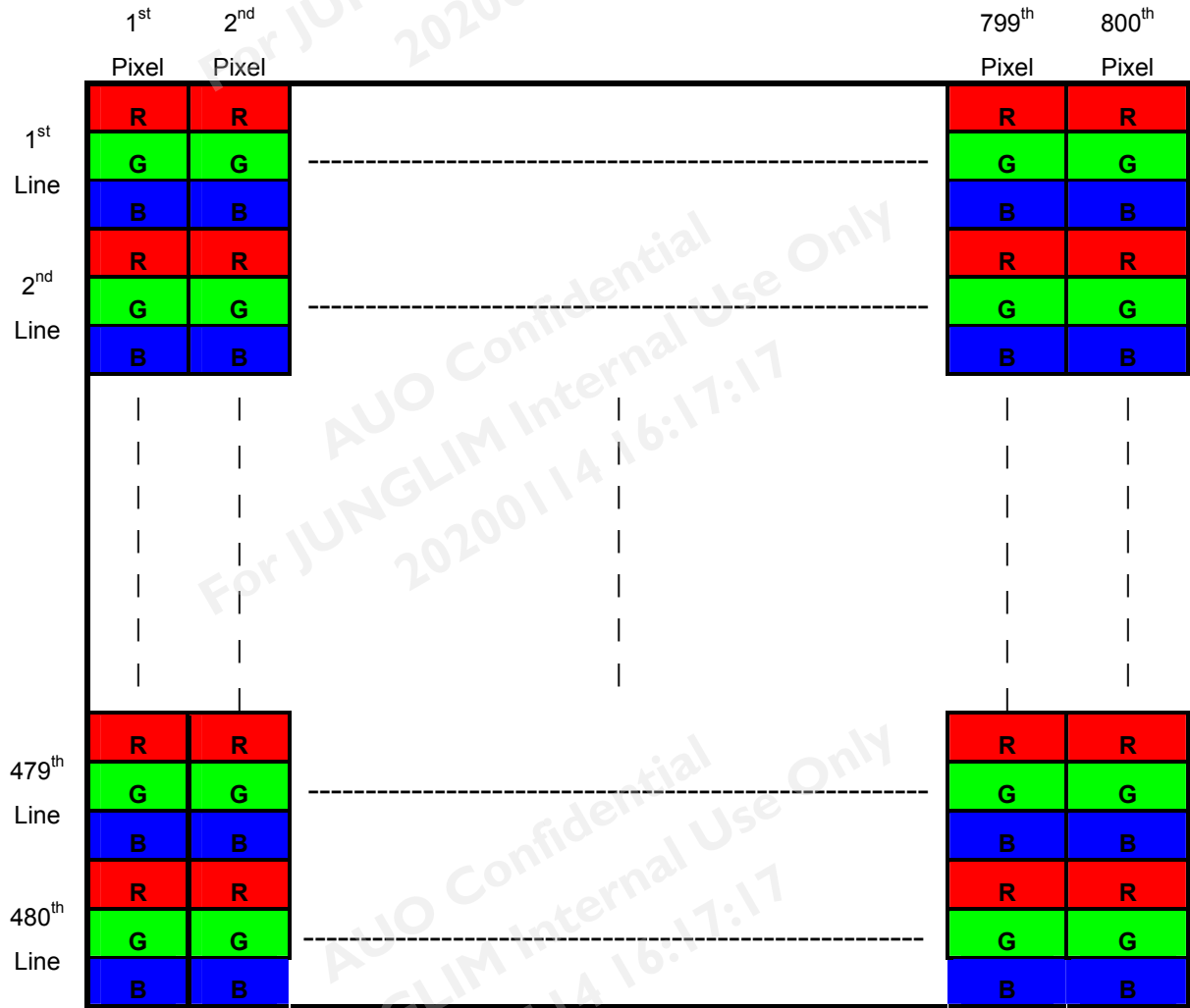

6.2 Signal Description

The module uses a LVDS receiver embedded in AUO's ASIC. LVDS is a differential signal technology for LCD interface and a high-speed data transfer device.

6.2.1 TFT LCD Module: LVDS Connector

Connector Name / Designation	Signal Connector
Manufacturer	慶良電子股份有限公司 (CHIEF LAND Electronic Co., Ltd.)
Connector Model Number	093G30-00001A-M4

Pin no	Symbol	Function	Remark
1	NC	NOT CONNECT	Note 1
2	LED+	LED ANODE	
3	LED+	LED ANODE	
4	NC	NOT CONNECT	
5	NC	NOT CONNECT	
6	NC	NOT CONNECT	
7	LED-	LED KATHODE	
8	LED-	LED KATHODE	
9	VDD	Power supply +3.3V	
10	VDD	Power supply +3.3V	
11	GND	Ground	
12	GND	Ground	
13	RXIN0N	Negative LVDS differential input	
14	RXIN0P	Positive LVDS differential input	
15	GND	Ground	
16	RXIN1N	Negative LVDS differential input	
17	RXIN1P	Positive LVDS differential input	
18	GND	Ground	
19	RXIN2N	Negative LVDS differential input	
20	RXIN2P	Positive LVDS differential input	
21	GND	Ground	
22	RXCLKN	Negative LVDS differential clock input	
23	RXCLKP	Positive LVDS differential clock input	
24	GND	Ground	
25	RXIN3N	Negative LVDS differential input	
26	RXIN3P	Positive LVDS differential input	
27	GND	Ground	

28	SEL 6/8	Low or NC → 6bit input mode High → 8bit input mode	
29	NC	NOT CONNECT	Note 1
30	NC	NOT CONNECT	Note 1

Note 1: AUO internal engineering use

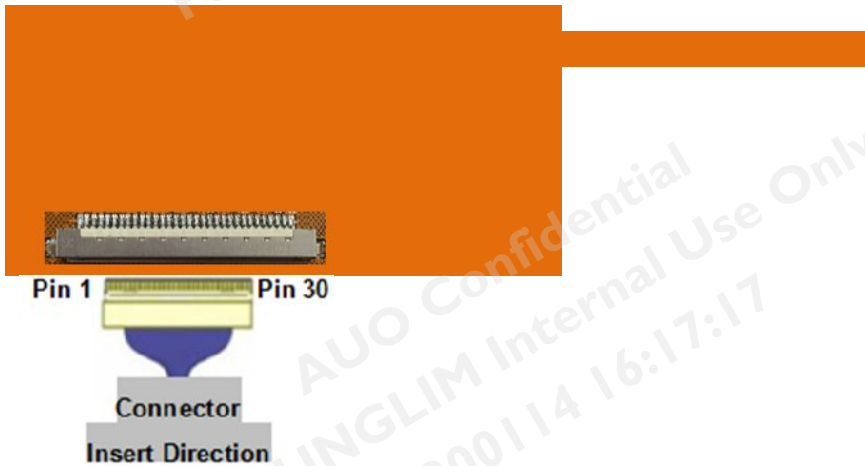

Note1: 30pin start from left side of connector.

Note2: Input signals shall be low or High-impedance state when VDD is off.

6.3 The Input Data Format

SEL68 = "Low" or "NC" for 6 bits LVDS Input

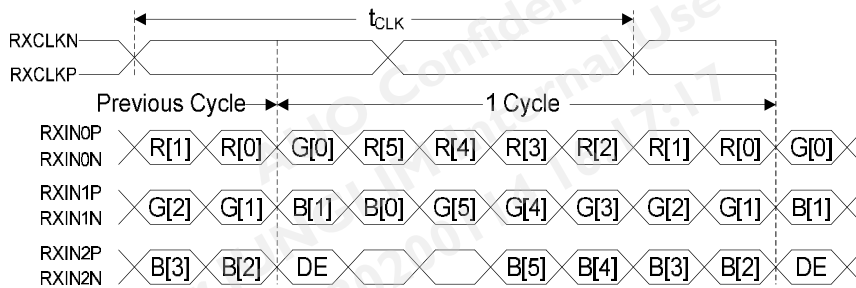

SEL68 = "High" for 8 bits LVDS Input(VESA Format)

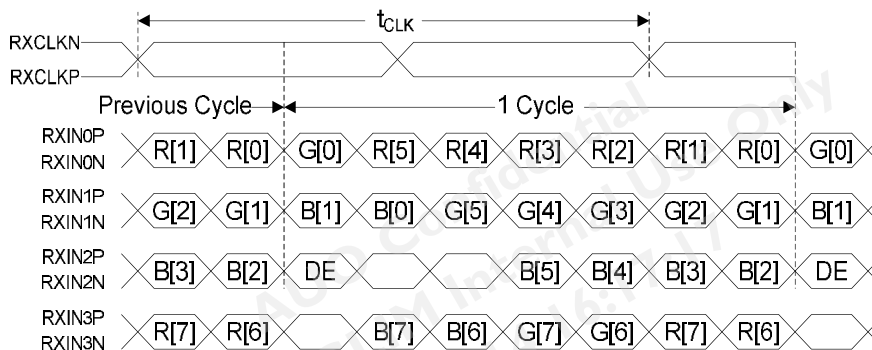



Signal Name	Description	Remark
R7 R6 R5 R4 R3 R2 R1 R0	Red Data 7 Red Data 6 Red Data 5 Red Data 4 Red Data 3 Red Data 2 Red Data 1 Red Data 0	Red-pixel Data For 8Bits LVDS input MSB: R7 ; LSB: R0 For 6Bits LVDS input MSB: R5 ; LSB: R0
G7 G6 G5 G4 G3 G2 G1 G0	Green Data 7 Green Data 6 Green Data 5 Green Data 4 Green Data 3 Green Data 2 Green Data 1 Green Data 0	Green-pixel Data For 8Bits LVDS input MSB: G7 ; LSB: G0 For 6Bits LVDS input MSB: G5 ; LSB: G0
B7 B6 B5 B4 B3 B2 B1 B0	Blue Data 7 Blue Data 6 Blue Data 5 Blue Data 4 Blue Data 3 Blue Data 2 Blue Data 1 Blue Data 0	Blue-pixel Data For 8Bits LVDS input MSB: B7 ; LSB: B0 For 6Bits LVDS input MSB: B5 ; LSB: B0
RXCLKN RXCLKP	LVDS Data Clock	
DE	Data Enable Signal	When the signal is high, the pixel data shall be valid to be displayed.

Note: Output signals from any system shall be low or Hi-Z state when VDD is off.

6.4 Interface Timing

6.4.1 Timing Characteristics

Signal	Symbol	Min.	Typ.	Max.	Unit	
Clock Frequency	$1/T_{\text{Clock}}$	33.2	37	45	MHz	
Vertical Section	Period	T_V	525	525	580	T_{Line}
	Active	T_{VD}	480			
	Blanking	T_{VB}	45	45	100	
Horizontal Section	Period	T_H	1054	1175	1395	T_{Clock}
	Active	T_{HD}	800			
	Blanking	T_{HB}	254	375	595	
Frame Rate	F	60			Hz	

Note : DE mode.

6.4.2 Input Timing Diagram

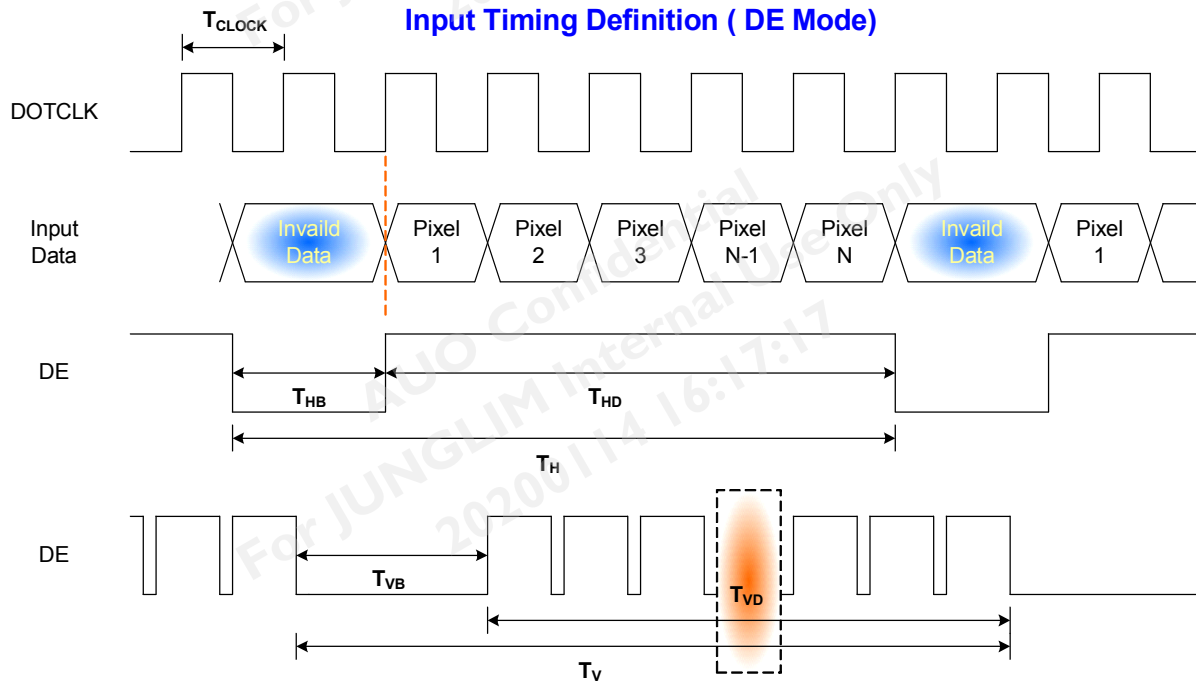



6.5 Power ON/OFF Sequence

VDD power and lamp on/off sequence is as below. Interface signals are also shown in the chart. Signals from any system shall be Hi-Z state or low level when VDD is off.

Panel Power on sequence:

Parameter	Value			Unit
	Min.	Typ.	Max.	
T1	1	-	-	ms
T2	7	-	-	ms
T3	0	-	-	ms
T4	300	-	-	ms

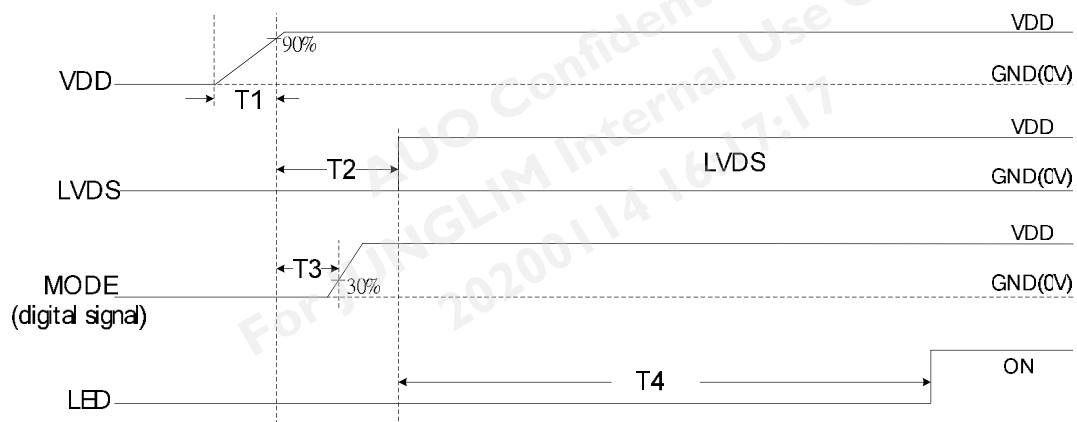

Panel Power off sequence:

Parameter	Value			Unit
	Min.	Typ.	Max.	
T1	350	-	-	ms
T2	0	-	-	ms

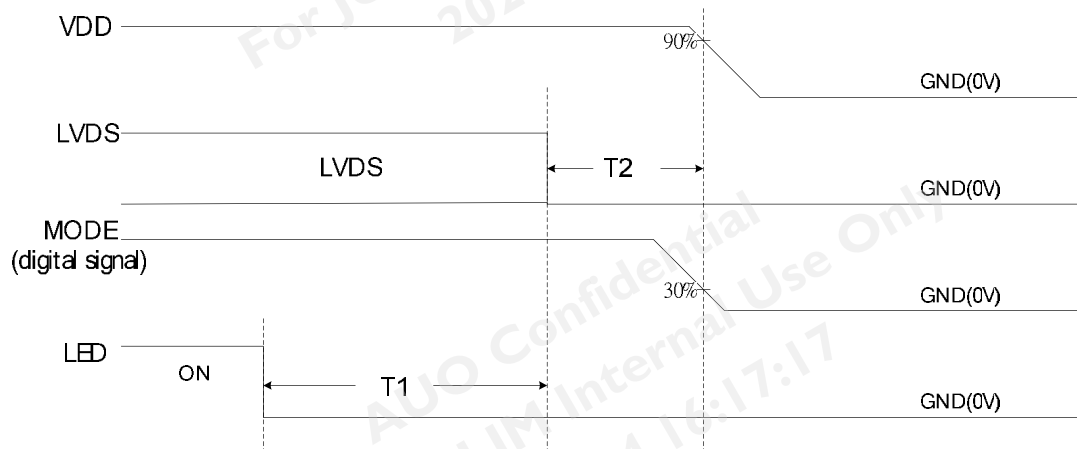



VDD ON/OFF:

Parameter	Value			Unit
	Min.	Typ.	Max.	
T1	700	--	-	ms

Note : VDD restart voltage should be under VDD X 0.1

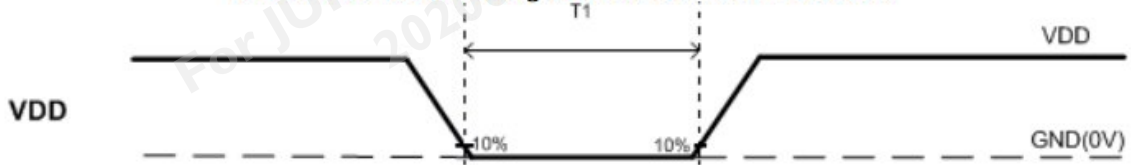

The above on/off sequence should be applied to avoid abnormal function in the display. Please make sure to turn off the power when you plug the cable into the input connector or pull the cable out of the connector.

AUO Confidential
 For JUNGLIM Internal Use Only
 2020/01/14 16:17:17

7. Reliability Test Criteria

Items	Required Condition	Note
Temperature Humidity Bias	60 °C /90%,300Hr	
High Temperature Operation	80 °C, 300Hr	
Low Temperature Operation	-30 °C, 300Hr	
Hot Storage	80 °C, 300 hours	
Cold Storage	-30 °C, 300 hours	
Thermal Shock Test	-30 °C ~ 80 °C /100 cycles 0.5Hrs/cycle	
Shock Test (Non-Operating)	50G,20ms,Half-sine wave,(+X,+Y,+Z)	
Vibration Test (Non-Operating)	Frequency: 10~55 Hz Stoke: 1.5mm Sweep: 10~55~10 Hz	
ESD	Contact : ± 8KV/ operation, Class B Air : ± 15KV / operation, Class B	Note 1
Drop (with carton)	Height: 61cm 1 corner, 3 edges, 6 surfaces	

Note1: According to EN61000-4-2 , ESD class B: Some performance degradation allowed. No data lost
 . Self-recoverable. No hardware failures.

Note2:

- Water condensation is not allowed for each test items.
- Each test is done by new TFT-LCD module. Don't use the same TFT-LCD module repeatedly for reliability test.
- The reliability test is performed only to examine the TFT-LCD module capability.
- To inspect TFT-LCD module after reliability test, please store it at room temperature and room humidity for 24 hours at least in advance.

9. Label and Packaging

9.1 Shipping Label (on the rear side of TFT-LCD display)



9.2 Carton Package

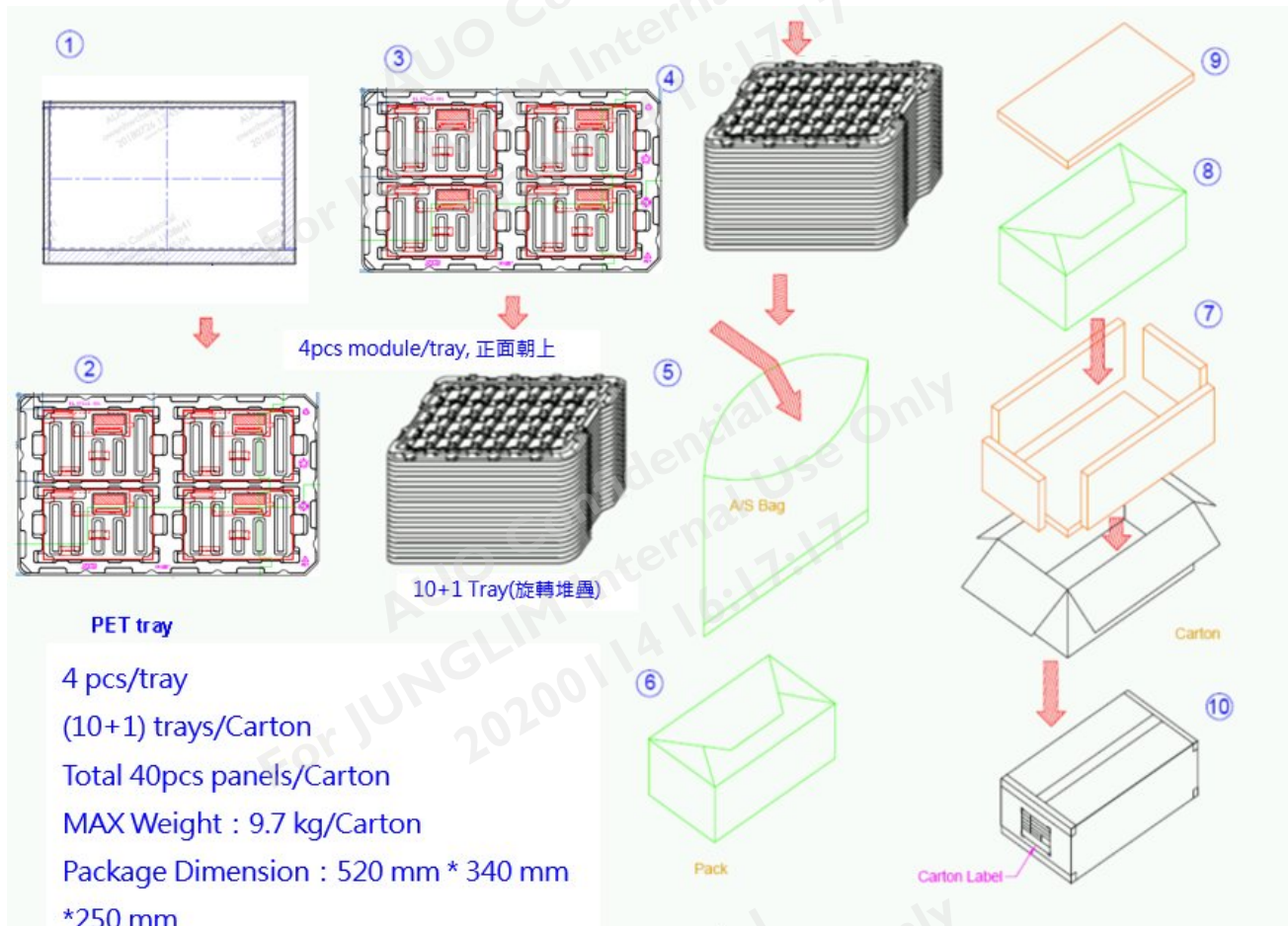



10 Safety

10.1 Sharp Edge Requirements

There will be no sharp edges or comers on the display assembly that could cause injury.

10.2 Materials

10.2.1 Toxicity

There will be no carcinogenic materials used anywhere in the display module. If toxic materials are used, they will be reviewed and approved by the responsible AUO toxicologist.

10.2.2 Flammability

All components including electrical components that do not meet the flammability grade UL94-V1 in the module will complete the flammability rating exception approval process.

The printed circuit board will be made from material rated 94-V1 or better. The actual UL flammability rating will be printed on the printed circuit board.

10.3 Capacitors

If any polarized capacitors are used in the display assembly, provisions will be made to keep them from being inserted backwards.

10.4 National Test Lab Requirement

The display module will satisfy all requirements for compliance to:

UL 60950-1 second edition

U.S.A. Information Technology Equipment