



DM-TFT700-504

7.0' 1024*600 350 nits TFT - LVDS FPC

CONTENT LIST

Cover -----	1
Content List-----	2
Record of Revisions-----	3
1. General Description-----	4
2. Electrical Specifications -----	6
3. Signal Timing Specification-----	9
4. Interface Connection -----	10
5. Optical Specification-----	11
6. Mechanical Characteristics-----	14
7. Packing Method -----	17
8. Product ID Rule-----	18
9. General Precautions -----	19
10. Applicable Scope -----	23

Record of Revisions

Revision	Date	Page	Description	Released by
Rev.0	2020.11.28		Update drawings, etc	

1.0 GENERAL DESCRIPTION

1.1 Introduction

is a color active matrix TFT-LCD Panel using amorphous silicon TFT's (Thin Film Transistors) as an active switching devices and with the integrated GG touch sensor. It is a transmissive type display operating in the normal black. This TFT-LCD has a 7.0 inch diagonally measured active area with WSVGA resolutions (1024 horizontal by 600 vertical pixel array). Each pixel is divided into Red, Green, Blue dots which are arranged in vertical stripe and this panel can display 16.7M colors.

1.2 Features

- 1.0t Glass (Total)
- High luminance and contrast ratio, low reflection and wide viewing angle
- Thin and light weight
- RoHS Compliant

1.3 Application

- 工控

1.4 General Specifications (H: horizontal length, V: vertical length)

Parameter	Specification	Unit	Remark
Active Area	154.2144(H) × 85.92(V)	mm	
Number of Pixels	1024(H) RGB × 600(V)	pixels	
Pixel Pitch	0.0502(H) × 0.1432(V)	mm	
Pixel Arrangement	RGB Vertical stripes		
Display Colors	16.7 M	colors	
Color Gamut	50%(typ.)		
Display Mode	Normally Black, Transmissive mode		
Dimensional Outline	164.9(H)×100(V)× 3.06(D)	mm	LCM
Viewing Direction (Human Eye)	U/D/L/R free viewing direction		Note 1
Weight	TBD	gram	

Note:

1. At the U/D/L/R direction, the viewing angle is same;
2. The TFT and CF LC Align Direction;

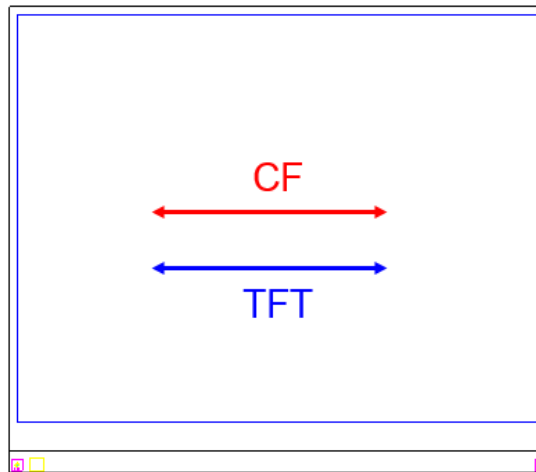

3. This product's compatible IC is EK79001HN & EK73215BCGA series.

2.0 ELECTRICAL SPECIFICATION

2.1 Absolute Maximum Ratings

The absolute maximum ratings are list on table as follows. When used out of the absolute maximum ratings, the LSI may be permanently damaged. Using the LSI within the following electrical characteristics limit is strongly recommended for normal operation. If these electrical characteristic conditions are exceeded during normal operation, the LSI will malfunction and cause poor reliability.

Parameter	Symbol	Value	Unit
Supply Voltage (MV)	AVSS- AVDD	-0.3~+13.5	V
Supply Voltage (HV)	VGH-VSS	-0.3~+20V	V
	VGL	0.3~-20V	
	VGH – VGL	<30	
Logic Input Voltage Range	VDD	-0.3~+3.6	V
Operating Temperature Range	TOPR	-20~+70	°C
Storage Temperature Range	TSTG	-30~+70	°C

Note:

If the absolute maximum rating of even is one of the above parameters is exceeded even momentarily, the quality of the product may be degraded. Absolute maximum ratings, therefore, specify the values exceeding which the product may be physically damaged. Be sure to use the product within the range of the absolute maximum ratings.

2.2 DC Characteristics

Item	Symbol	Test Condition	Min.	Typ.	Max.	Unit	Note
Power voltage	V_{DD}	Operating Voltage	2.4	3.3	3.6	V	
	AV_{DD}	Operating Voltage	9.0	9.6	9.8	V	
	V_{GH}	Gate on voltage	17	18	19	V	
	V_{GL}	Gate off voltage	-7	-6	-5	V	
Input signal voltage	V_{COM}	COM voltage	2.9	3.1	3.2	V	
Input logic high voltage	V_{IH}	H	$0.7DV_{DD}$	-	DV_{DD}	V	
Input logic low voltage	V_{IL}	L	0	-	$0.3DV_{DD}$	V	

Be sure to apply DV_{DD} and V_{GL} to the LCD first, and then apply V_{GH} .

2.3 Backlight Driving Conditions

Parameter	Symbol	Min	Typ	Max	Unit	Remark
LED Forward Voltage	V_F	-	12.8	13.6	V	-
LED Forward Current	I_F	-	120	-	mA	-
LED Power Consumption	P_{LED}	-	1.632	-	W	Note 1

Notes:

1. Calculator Value for reference $I_{LED} \times V_{LED} \times LED \text{ Quantity} = P_{LED}$
2. The LED Life-time define as the estimated time to 50% degradation of initial luminous.

2.4 Power Consumption

Parameter	Symbol	Typ	Max	Unit	Remark
Normal mode	I_{VDD}	26.0	34	mA	Note
Normal mode	I_{AVDD}	19.5	25.7		
Sleep mode	I_{VDD}	-	-	uA	

Note:

Frame rate=60HZ, Typ. Pattern White pattern, worst case pattern 1x1 checker 25°C.

2.5 Power ON/OFF Sequence



NOTE :This section is only for reference,Details please refer to the IC specification.

2.6 The Input Data Format

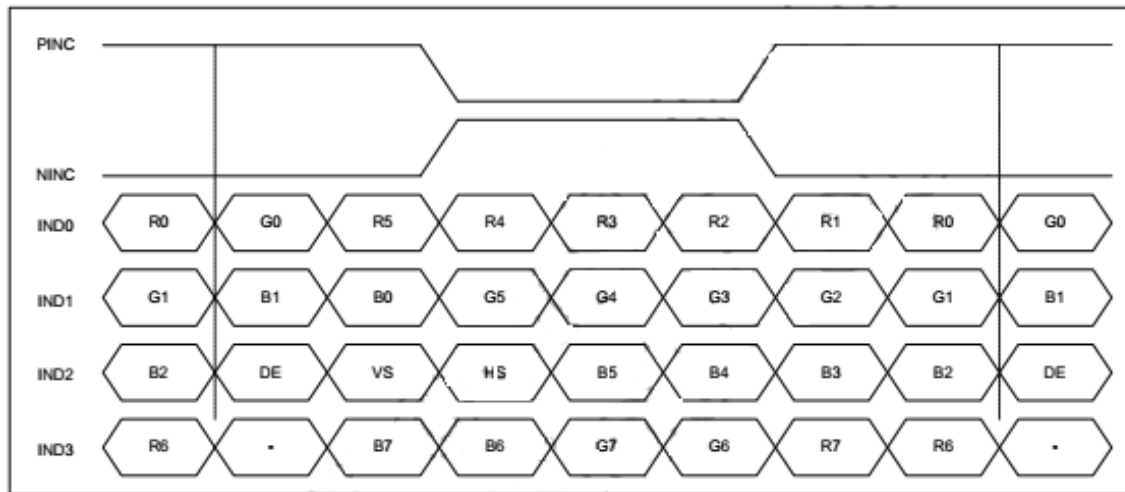

8-bit LVDS Input

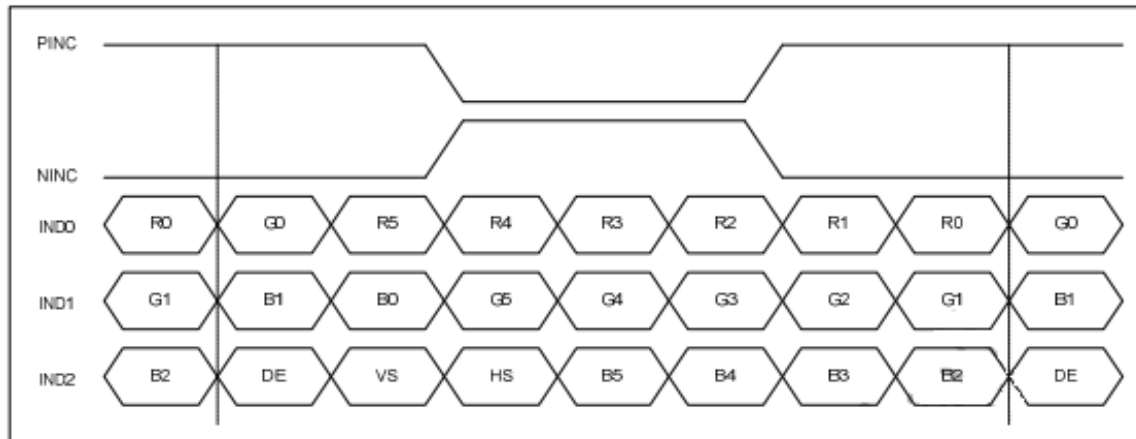

6-bit LVDS input

3.0 SIGNAL TIMING SPECIFICATION

Vertical Timing

Parameter	Symbol	Min	Typ	Max	Unit	Remark
Vertical display Area	tvd	-	600	-	TH	
VS period time	tv	610	635	800	TH	
VS pulse width	tvpw	1	-	20	TH	
VS Blanking	tvb	10	35	200	TH	
VS Front Porch	tvfp	1	12	127	TH	

Horizontal Timing

Parameter	Symbol	Min	Typ	Max	Unit	Remark
Horizontal Display Area	thd	-	1024	-	DCLK	
DCLK frequency	fck	44.9	51.2	63.2	MHz	
One horizontal line	th	1200	1344	1400	DCLK	
HS pulse width	thpw	1	-	140	DCLK	
HS Blanking	thb	90	320	376	DCLK	
HS Front Porch	thfp	16	160	216	DCLK	

NOTE :This section is only for reference,Details please refer to the IC specification.

4.0 INTERFACE CONNECTION

Pin No.	Symbol	Function	Remark
1	LED-	Power for LED Backlight(Cathode)	
2	LED+	Power for LED Backlight(Anode)	
3	RESET	Global reset pin(2.8V)	
4	STBYB	Standby mode ,normally pulled high	
5	GND	Power Ground	
6	RXCLKIN-	-LVDS differential clock input	
7	RXCLKIN+	+LVDS differential clock input	
8	GND	Power Ground	
9	RXIN0-	-LVDS differential data input	
10	RXIN0+	+ LVDS differential data input	
11	GND	Power Ground	
12	RXIN1-	- LVDS differential data input	
13	RXIN1+	+LVDS differential data input	
14	GND	Power Ground	
15	RXIN2-	- LVDS differential data input	
16	RXIN2+	+LVDS differential data input	
17	GND	Power Ground	
18	RXIN3-	-LVDS differential data input	
19	RXIN3+	+LVDS differential data input	
20	GND	Power Ground	
21	AVDD	Analog power +9.6V(typ)	
22	VCOM	Common Voltage 3.2V(typ)	
23	VGL	Gate off voltage -6V(typ)	
24	VGH	Gate on voltage +18V(typ)	
25	VDD	Power Supply,3.3V(typ)	
26	GND	Power Ground	
27	TP-VDD(NC)	TP Power Supply(NC)	
28	TP-INT(NC)	Interrupt pin for interrupt request for CTP.(NC)	
29	TP-SCL(NC)	I2C clock input signal for CTP (NC)	
30	TP-SDA(NC)	I2C data input signal for CTP (NC)	
31	TP-RST(NC)	Reset pin for TP (NC)	
32	TP-GND	Power Ground	

5.0 OPTICAL SPECIFICATIONS

5.1 Overview

The test of Optical specifications shall be measured in a dark room (ambient luminance ≤ 1 lux and temperature = $25 \pm 2^\circ\text{C}$) with the equipment of Luminance meter system (Topcon SR-UL1R and Westar TRD-100A) and test unit shall be located at an approximate distance 50cm from the LCD surface at a viewing angle of θ and Φ equal to 0° . The center of the measuring spot on the Display surface shall stay fixed.

The backlight should be operating for 30 minutes prior to measurement.

5.2 Optical Specifications

Parameter		Symbol	Condition	Min.	Typ.	Max.	Unit	Remark
Viewing Angle	Horizontal	θ_3	CR > 10		85		°	Note 1
		θ_9			85		°	
	Vertical	θ_{12}			85		°	
		θ_6			85		°	
Contrast Ratio		CR	$\theta = 0^\circ$	700	800			Note 2
Luminance		Bp	$\theta = 0^\circ$	300	350		cd/m ²	Note 3
Uniformity			$\theta = 0^\circ$	70	75	-	%	Note 4
NTSC		NTSC	$\theta = 0^\circ$		50	-	%	
Reproduction Of color	Red	Rx	$\theta = 0^\circ$		0.623			Note 5
		Ry			0.331			
	Green	Gx			0.279			
		Gy			0.532			
	Blue	Bx			0.142			
		By			0.143			
White		Wv	$\theta = 0^\circ$	0.260	0.300	0.340		
		Wv		0.028	0.320	0.360		
Response Time		Tr+Tf	25°C		30	40	ms	Note 6

Note:

- Viewing angle is the angle at which the contrast ratio is greater than 10. The viewing are determined for the horizontal or 3, 9 o'clock direction and the vertical or 6, 12 o'clock direction with respect to the optical axis which is normal to the LCD surface (see FIG.2).
- Contrast measurements shall be made at viewing angle of $\theta = 0^\circ$ and at the center of the LCD surface. Luminance shall be measured with all pixels in the view field set first to white, then to the dark (black) state. (See FIG. 2) Luminance Contrast Ratio (CR) is defined mathematically.

$$CR = \frac{\text{Luminance when displaying a white raster}}{\text{Luminance when displaying a black raster}}$$

3. Surface luminance is the center point across the LCD surface 50cm from the surface with all pixels displaying white. This measurement shall be taken at the locations shown in FIG. 2.
4. Uniformity measurement shall be taken at the locations shown in FIG. 2&3, for a total of the measurements per display, measure surface luminance of these nine points across the LCD surface 50cm from the surface with all pixels displaying white.

$$\text{Uniformity} = \frac{\text{Min Luminance of 400 points}}{\text{MaxLuminance of 400 points}} \times 100\%$$

5. The color chromaticity coordinates specified in Table1 shall be calculated from The spectral data measured with all pixels first in red, green, blue and white. Measurements shall be made at the center of the Module.
 6. The electro-optical response time measurements shall be made as FIG.4 by switching the "data" input signal ON and OFF.
- The times needed for the luminance to change from 10% to 90% is Tr and 90% to 10% is Tf.

Figure 1. The definition of Vth & Vsat

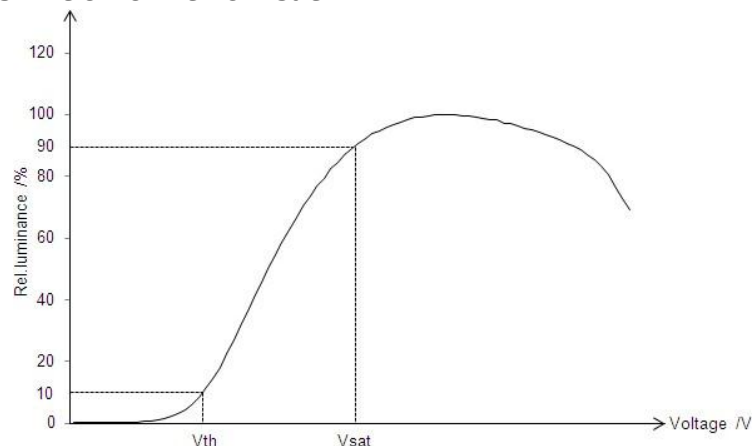

Figure 2. Measurement Set Up

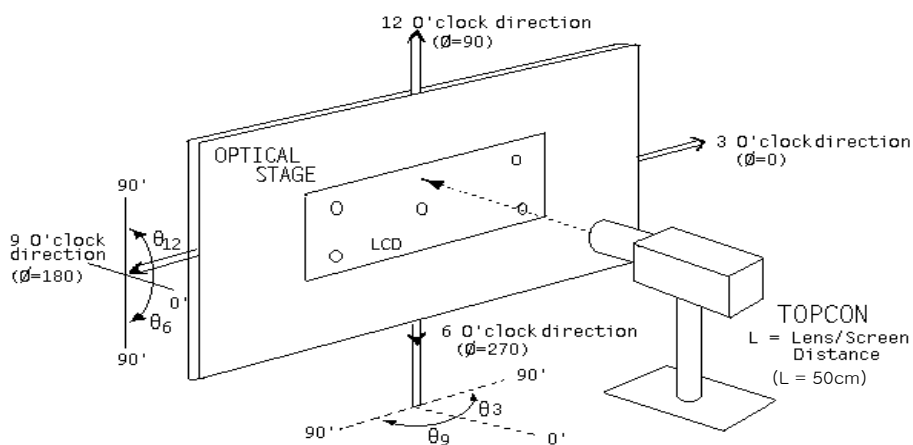

Figure 3. Uniformity Measurement Locations

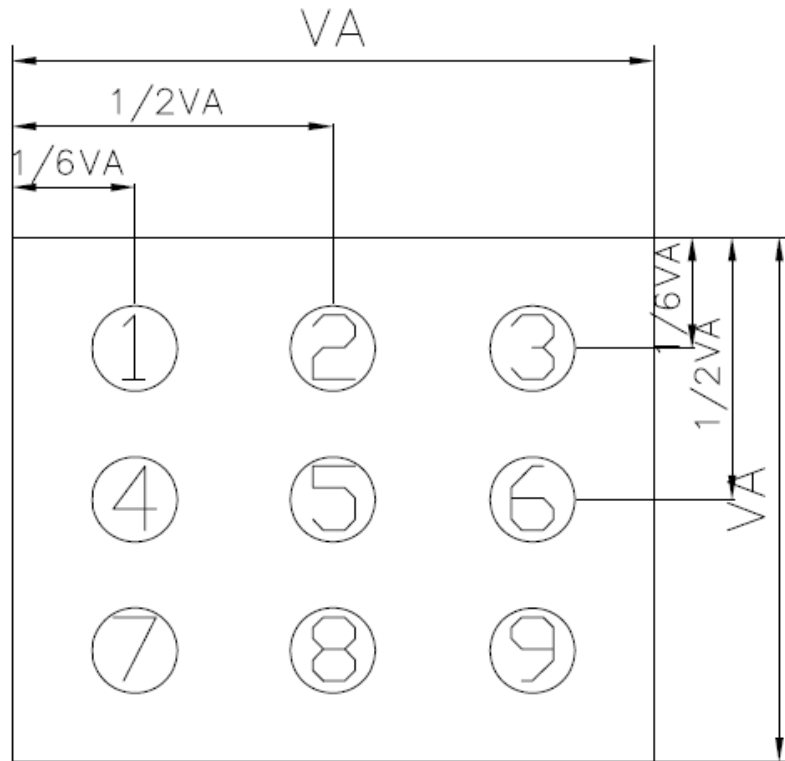
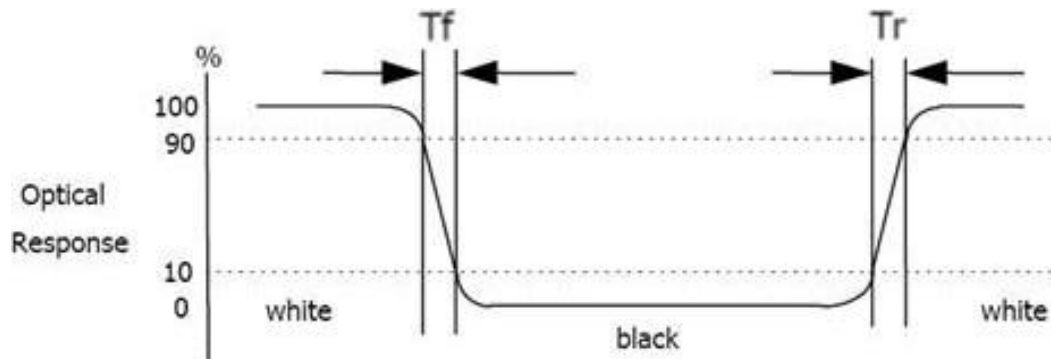

Figure 4. Response Time Testing



6.0 MECHANICAL CHARACTERISTICS

6.1 Dimension Requirements for LCD Part

Mechanical outlines for the panel (H: horizontal length, V: Vertical length)

Parameter	Specification	Unit	Remark
Panel size	162.2(H) × 95.7(V)	mm	
CF size	159(H) × 91(V)	mm	
Active area	154.2144(H) × 85.92(V)	mm	
Number of pixels	1024(H)RGB × 600(V)	pixels	
	(1 pixel = R + G + B dots)		
Pixel pitch	0.0502(H) × 0.1432(V)	mm	
Pixel arrangement	RGB Vertical Stripe		
Panel ID	10 × 2	mm	
COG pad area	4.7	mm	
D-IC to FPC distance	0.64	mm	Note
D-IC width	0.62	mm	
D-IC to CF edge	2.44	mm	
FPC to Glass edge	0.2	mm	
FPC width	25.885	mm	
Seal Area (U/D/L/R)	1.05/3.78/1.2/1.2	mm	
Dimensional outline	164.9(H) × 100(V) × 3.06(D)	mm	Module
Display mode	Normally Black		

Note:

The size specified is calculated by IC-driver EK79001HN.

Figure 5. LCM Outline Dimension

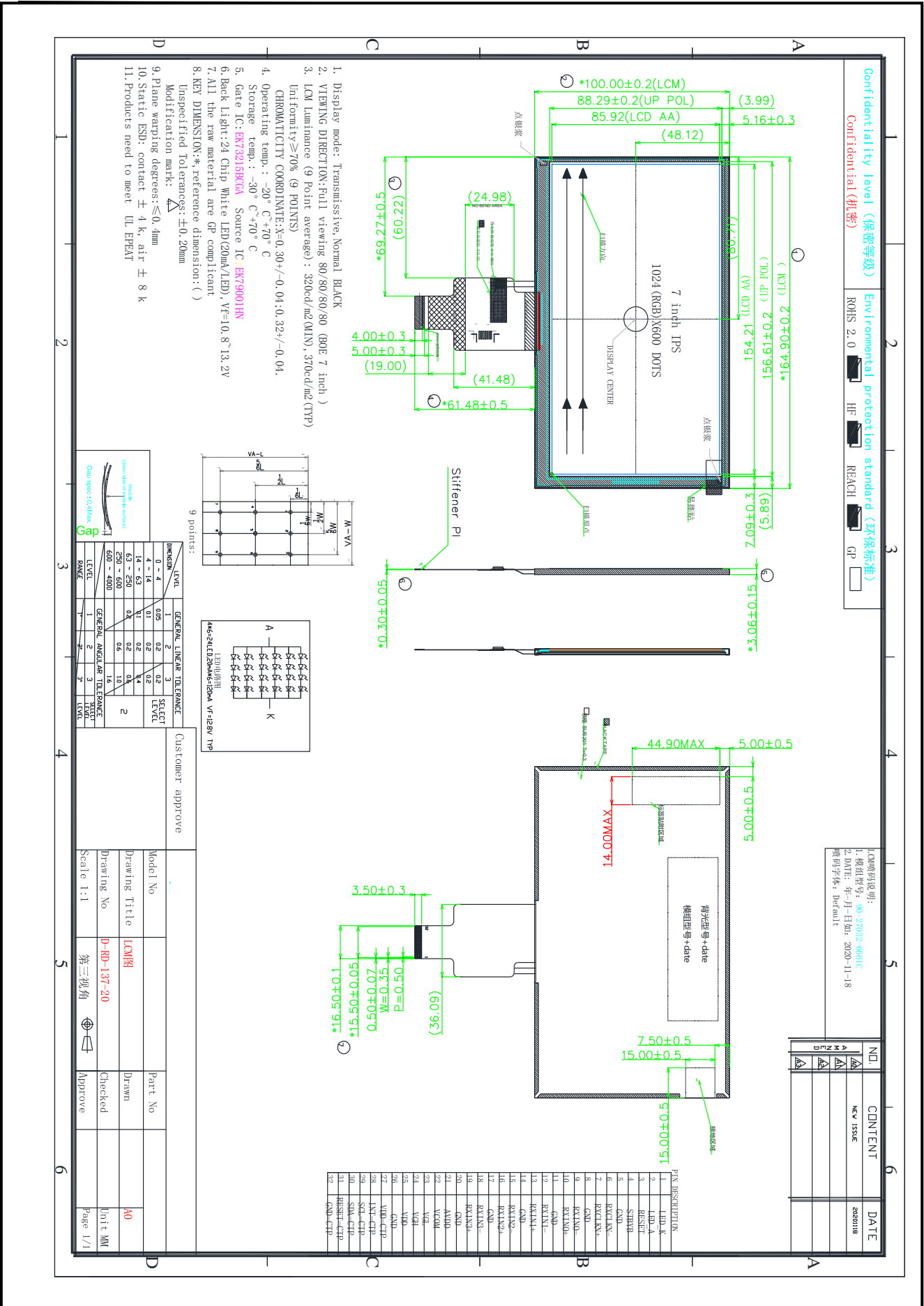

Confidentiality level (保密等级) Environmental protection standard (环保标准)
 Confidential (机密) ROHS 2.0 HF REACH GP

LOM说明:
 1. 装订号: 90-27032-6691C
 2. DATE: 年-月-日: 2020-11-18
 顺序字母: Default

NO	CONTENT	DATE
1	NEW ISSUE	2020/11/18
	reissue	

PIN DESCRIPTION

1	LD0-K
2	LD0-A
3	RESET
4	STRAP
5	GND
6	RX1CLK
7	RX1EN
8	GND
9	RX1ND
10	RX1NO
11	GND
12	RX1NI
13	RX1NI
14	GND
15	RX1NO
16	RX1NO
17	GND
18	RX1NO
19	RX1NO
20	GND
21	AVDD
22	VDD
23	VDD
24	VDD
25	VDD
26	VDD
27	VDD
28	VDD
29	VDD
30	SDDA-CPP
31	RESIST-CPP
32	GND-CPP

1. Display mode: Transmissive, Normal BLACK
2. VIEWING DIRECTION: Full viewing 80/80/80/80 (BOE 7 inch)
3. LCM Lumiance (9 Point average): 320cd/m2(MIN), 370cd/m2(TYP)
- Uniformity: ≥70% (9 POINTS)
- CHROMATICITY COORDINATE: X=0.30±/0.04; Y=0.32±/0.04.
4. Operating temp.: -20°C~+70°C
- Storage temp.: -30°C~+70°C
5. Gate IC: B7721530CA Source IC: B7790011N
6. Back Light: 24 Chip White LED(20mA/LED), VF=10.8~13.2V
7. All the raw material are GP compliant
8. KEY DIMENSION*: reference dimension: ()
- Unspsified Tolerances: ±0.20mm
- Modification mark: A
9. Plane warping degress: ≤0.4mm
10. Static ESD: contact ±4 k, air ±8 k
11. Products need to meet UL EPEAT

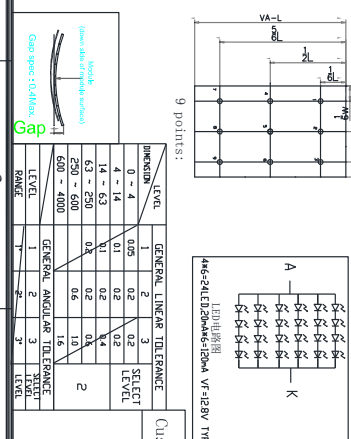

DIMENSION	LEVEL	1	2	3	SELECT LEVEL
0 - 4	0.05	0.2	0.2	0.2	2
4 - 14	0.1	0.2	0.2	0.2	2
14 - 53	0.15	0.2	0.2	0.2	2
53 - 83	0.2	0.2	0.2	0.2	2
83 - 250	0.3	0.2	0.2	0.2	2
250 - 500	0.4	0.2	0.2	0.2	2
500 - 600	0.5	0.2	0.2	0.2	2
600 - 4000	0.6	0.2	0.2	0.2	2

ANGLE	LEVEL	1	2	3	SELECT LEVEL
0° - 10°	1	2	2	2	2
10° - 30°	2	2	2	2	2

Customer approve

Model No. Part No.

Drawing Title: LCM图

Drawing No: D-RD-137-20

Scale: 1:1

第三视角

Drawn: Checked: Approve:

Unit: MM

Page: 1/1

Figure 6. Panel Dedicated Dimension (unit: mm)

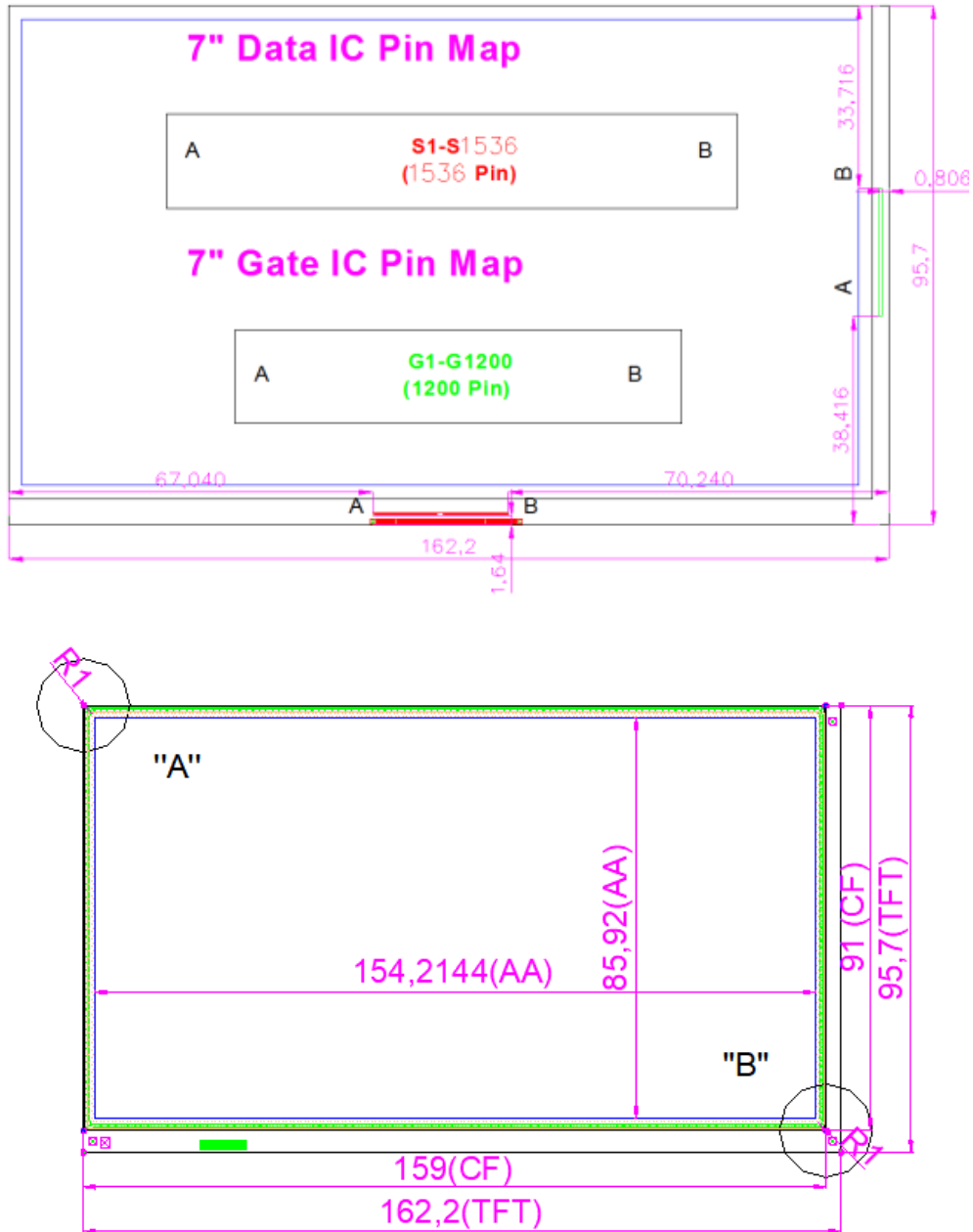

7.0 PACKING METHOD

7.1 Packing Process

- 将 2pcs LCM 平放入Tray
- Panel正面朝上放置
- 产品上放置1pcs EPE Spacer

- 将21pcs PET Tray 套入PE袋
- Tray 旋转码放 顶部1pcs 空Tray

- 将PE袋放入Inner Box
- 上下放置EPE Cover
- 40pcs/Box

- 每个Pallet上放5层Box
- 1层6箱, 平齐码放6ea Box
- Pallet外进行缠膜包装
- 1200pcs Panel / Pallet

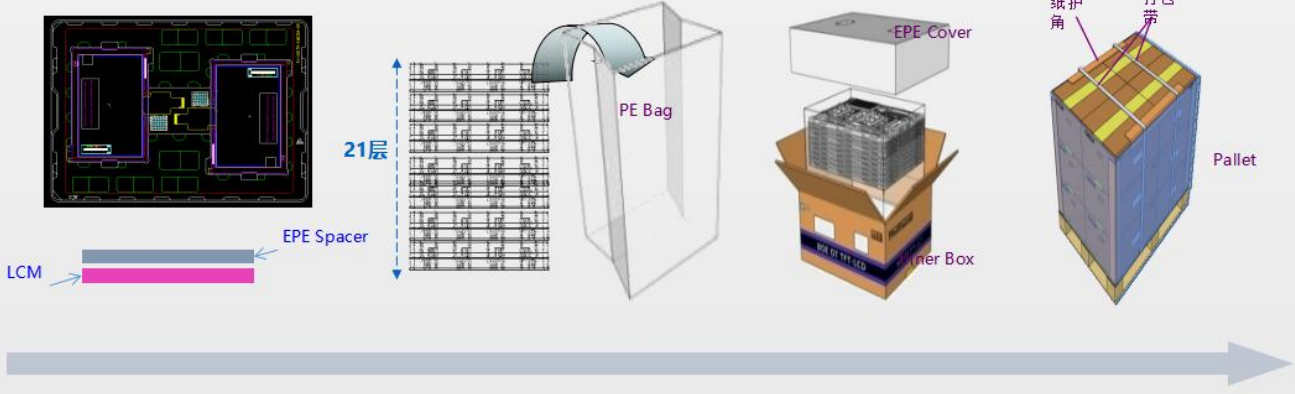

8.0 PRODUCT ID RULE

 G V 070 WS M - N 1 0

① ② ③ ④ ⑤ ⑥ ⑦ ⑧

① <Application area> ② <Mode> ③ <Size> ④ <Resolution>

Code	Description	Code	Description	Code	Description	Code	Description
Q	Smart home	V	ADS-a Si	036	3.6"	X0	1024x768
B	Mobile	S	ADS-LTPS	022	2.2"	QC	QCIF
H	TV	T	TN-a Si	018	1.77"	QV	QVGA

⑤ <Product type> ⑥ <Production state> ⑦ <Product THK> ⑧ <Product Rev>

Code	Description	Code	Description	Code	Description	Code	Description
M	Module	T	Touch on cell	4	0.4mm	0	First Mode
A	Array	E	In Cell Touch	6	0.6mm	1	Second Mode
S	Q-Panel Slimming	A	Add On Touch	5	0.5mm	2	Third Mode

9.0 General Precautions

9.1 Handling

- (1) Use fingerstalls with soft gloves in order to keep display clean during the incoming inspection and assembly process.
- (2) You must mount a module using specified mounting holes (Details refer to the drawings).
- (3) Please make sure to avoid external forces applied to the Source FPC and D-IC during the process of handling or assembling. If not, It causes panel damage or malfunction.
- (4) Note that polarizers are very fragile and could be easily damaged. Do not touch, push or rub the exposed polarizers with glass, tweezers or anything harder than HB pencil lead. And please do not rub with dust clothes with chemical treatment.
- (5) Do not pull or fold the source D-IC which connect the source FPC and the panel. Do not pull or fold the LED wire.
- (6) After removing the protective film, when the surface becomes dusty, please wipe gently with absorbent cotton or other soft materials like chamois soaks with alcohol or purified water. Do not strong polar solvent because they cause chemical damage to the polarizer.
- (7) Wipe off saliva or water drops as soon as possible. Their long time contact with polarizer causes deformations and color fading.
- (8) Protection film for polarizer on the module shall be slowly peeled off just before use so that the electrostatic charge can be minimized.
- (9) Since the LCD is made of glass, do not apply strong mechanical impact or static load onto it. Handling with care since shock, vibration, and careless handling may seriously affect the product. If it falls from a high place or receives a strong shock, the glass may be broken.
- (10) Do not disassemble the module.
- (11) To determine the optimum mounting angle, refer to the viewing angle range in the specification for each model.
- (12) If the customer's set presses the main parts of the LCD, the LCD may show the abnormal display. But this phenomenon does not mean the malfunction of the LCD and should be pressed by the way of mutual agreement.
- (13) Do not drop water or any chemicals onto the LCD's surface.

9.2 Operating Precautions

- (1) Be careful for condensation at sudden temperature change. Condensation makes damage to polarizer or electrical contacted parts. And after fading condensation, smear or spot will occur.
- (2) Module has high frequency circuits. Sufficient suppression to the electromagnetic interference shall be done by system manufacturers. Grounding and shielding methods may be important to

minimized the interference.

(3) The electrochemical reaction caused by DC voltage will lead to LCD degradation, so DC drive should be avoided.

(4) The LCD modules use C-MOS LSI drivers, so customers are recommended that any unused input terminal would be connected to Vdd or Vss, do not input any signals before power is turn on, and ground you body, work/assembly area, assembly equipments to protect against static electricity.

(5) Do not exceed the absolute maximum rating value. (supply voltage variation, input voltage variation, variation in part contents and environmental temperature, and so on) Otherwise the Module may be damaged.

(6) Design the length of cable to connect between the connector for back-light and the converter as short as possible and the shorter cable shall be connected directly. The longer cable between that of back-light and that of converter may cause the luminance of LED to lower and need a higher startup voltage(Vs).

(7) Connectors are precise devices for connecting FPC and transmitting electrical signals. Operators should insert and unplug MDL in parallel when assembling MDL.

(8) Do not connect or disconnect the cable to/ from the module at the "Power On" condition.

(9) Obey the supply voltage sequence. If wrong sequence is applied, the module would be damaged.

(10) Do not re-adjust variable resistor or switch etc.

9.3 Electrostatic Discharge Control

(1) Since a module is composed of electronic circuits, it is not strong to electrostatic discharge. Make certain that treatment persons are connected to ground through wrist band etc. And don't touch interface pin directly. Keep products as far away from static electricity as possible.

(2) Avoid the use work clothing made of synthetic fibers. We recommend cotton clothing or other conductivity-treated fibers.

9.4 Precautions for Strong Light Exposure

Strong light exposure causes degradation of polarizer and color filter. It is not allowed to store or run directly in strong light or in high temperature and humidity for a long time.

9.5 Storage Precautions

When storing modules as spares for a long time, the following precautions are necessary.

(1) The polarizer surface should not come in contact with any other object. It is recommended that they be stored in the container in which they were shipped. Temperature : 5 ~ 40 °C

- (2) Humidity : 35 ~ 75 %RH
- (3) Period : 6 months
- (4) Control of ventilation and temperature is necessary.
- (5) Please make sure to protect the product from strong light exposure, water or moisture. Be careful for condensation.
- (6) Store in a polyethylene bag with sealed so as not to enter fresh air outside in it.
- (7) Do not store the LCD near organic solvents or corrosive gasses.
- (8) Please keep the modules at a circumstance shown below Fig.

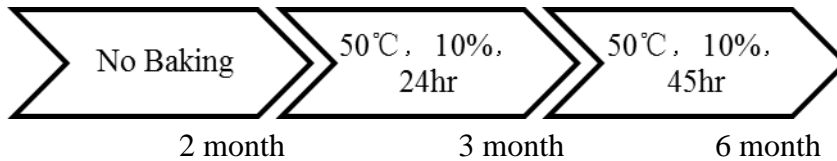

9.6 Handling Precautions for Protection Film

- (1) Remove the protective film slowly, keeping the removing direction approximate 30-degree not vertical from panel surface, If possible, under ESD control device like ion blower, and the humidity of working room should be kept over 50%RH to reduce the risk of static charge.
- (2) In handling the LCD, wear non-charged material gloves. And the conducting wrist to the earth and the conducting shoes to the earth are necessary.

9.7 Operation Condition Guide

- (1) Normal operating condition
 - Temperature: 0 ~ 40°C
 - Operating Ambient Humidity : 10 ~ 90 %
 - Display pattern: dynamic pattern (Real display)
- (2) Black image or moving image is strongly recommended as a screen save.
- (3) Lifetime in this spec. is guaranteed only when Commercial Display is used according to operating usages.
- (4) Please contact BOE in advance when you display the same pattern for a long time.
- (5) If the Module keeps displaying the same pattern for a long period of time, the image may be "sticked" to the screen. To avoid image sticking, it is recommended to use a screen saver.
- (6) Do not exceed the absolute maximum rating value. (supply voltage variation, input voltage variation, variation in part contents and environmental temperature, and so on) Otherwise the Module may be damaged.
- (7) Dew drop atmosphere should be avoided.
- (8) The storage room should be equipped with a good ventilation facility, which has a temperature

controlling system.

(9) When expose to drastic fluctuation of temperature (hot to cold or cold to hot) ,the LCD may be affected; Specifically, drastic temperature fluctuation from cold to hot ,produces dew on the LCD's surface which may affect the operation of the polarizer and the LCD.

(10) Response time will be extremely delayed at lower temperature than the operating temperature range and on the other hand at higher temperature LCD may turn black at temperature above its operational range. However those phenomena do not mean malfunction or out of order with the LCD. The LCD will revert to normal operation once the temperature returns to the recommended temperature range for normal operation.

9.8 Others

(1)When returning the module for repair or etc., Please pack the module not to be broken. We recommend to use the original shipping packages.

(2) If the liquid crystal material leaks from the panel, it should be kept away from the eyes or mouth. In case of contact with hands, legs or clothes, it must be washed away thoroughly with soap.

(3) For the crash damaged or unnecessary LCD, it is recommended to wash off liquid crystal by either of solvents such as acetone and ethanol and should be burned up later.

(4) If you should swallow the liquid crystal, first, wash your mouth thoroughly with water, then drink a lot of water and induce vomiting, and then, consult a physician.

(5) If the liquid crystal should get in your eyes, flush your eyes with running water for at least fifteen minutes.

10.0 Applicable Scope

- This product specification only applies to the products manufactured and sold by our company.
- Any specification, quality etc. about other parts mentioned in this product spec are no concern of our company.