



DM-TFT700-501

7.0' 800*480 300 nits TFT - TTL

Contents

1. General Specifications	4
2. Pin Assignment	5
3. Operation Specifications	8
3.1. Absolute Maximum Ratings	8
3.2. Typical Operation Conditions	9
3.3. Power Sequence	10
3.4. Timing Characteristics	11
4. Optical Specifications	14
5. Reliability Test Items	18
6. General Precautions	19
6.1. Safety	19
6.2. Handling	19
6.3. Static Electricity	19
6.4. Storage	19
6.5. Cleaning	19
7. Mechanical Drawing	20
8. Package Drawing	21

1. General Specifications

No.	Item	Specification	Remark
1	LCD size	7.0 inch(Diagonal)	
2	Driver element	a-Si TFT active matrix	
3	Resolution	800X3(RGB)X480	
4	Display mode	Normally white, Transmissive	
5	Dot pitch	0.0635(W)X0.1905(H) mm	
6	Active area	152.4 (W)X91.44 (H) mm	
7	Module size	165(W)X104(H)X5.5(D) mm	Note 1
8	Surface treatment	Anti-Glare	
9	Color arrangement	RGB-stripe	
10	Interface	Digital (TTL)	
11	Backlight power consumption	2.500W (Typ.)	Note 2
12	Panel power consumption	0.281W (Typ.)	
13	Weight	112.9g (Typ.)	

Note 1: Refer to Mechanical Drawing.

Note 2: Including LED Driver power consumption.

2. Pin Assignment

TTL Connector is used for the module electronic interface. The recommended model is “196534-40041-3 (40 pin)”, manufactured by P-two, or compatible CONN.

Pin No.	Symbol	I/O	Function	Remark
1	V _{LED}	P	Power supply for LED Driver	
2	V _{LED}	P	Power supply for LED Driver	
3	ADJ	I	Adjust the led brightness with PWM Pulse	Note 1,2
4	G _{LED}	P	Ground for LED circuit	
5	G _{LED}	P	Ground for LED circuit	
6	V _{CC}	P	Power supply for digital circuit	
7	V _{CC}	P	Power supply for digital circuit	
8	MODE	I	DE or HV mode control	Note 3
9	DE	I	Data enable	
10	VS	I	Vsync signal input	
11	HS	I	Hsync signal input	
12	GND	P	Power ground	
13	B5	I	Blue data input (MSB)	
14	B4	I	Blue data input	
15	B3	I	Blue data input	
16	GND	P	Power ground	
17	B2	I	Blue data input	
18	B1	I	Blue data input	
19	B0	I	Blue data input(LSB)	
20	GND	P	Power ground	
21	G5	I	Green data input(MSB)	
22	G4	I	Green data input	
23	G3	I	Green data input	
24	GND	P	Power ground	
25	G2	I	Green data input	
26	G1	I	Green data input	

27	G0	I	Green data input(LSB)	
28	GND	P	Power ground	
29	R5	I	Red data input(MSB)	
30	R4	I	Red data input	
31	R3	I	Red data input	
32	GND	P	Power ground	
33	R2	I	Red data input	
34	R1	I	Red data input	
35	R0	I	Red data input(LSB)	
36	GND	P	Power ground	
37	DCLK	I	Sample clock	
38	GND	P	Power ground	
39	L/R	I	Select left or right scanning direction	Note 4,5
40	U/D	I	Select up or down scanning direction	Note 4,5

Note1: Pin3. is used to adjust brightness.

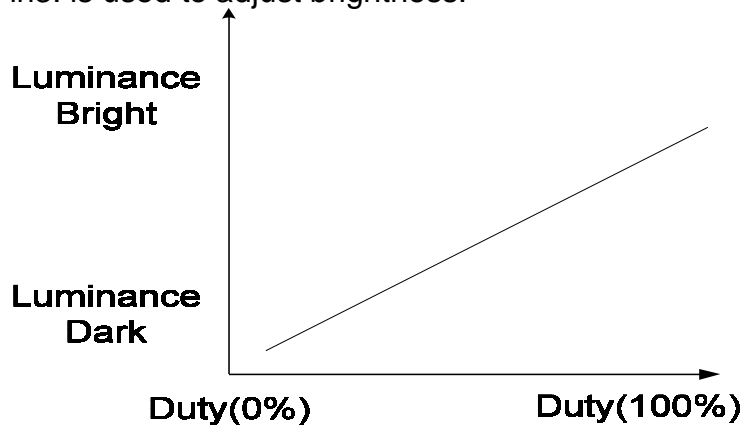

Note 2: ADJ signal=0 ~3.3V; Operating frequency:100 Hz ~ 25K Hz.

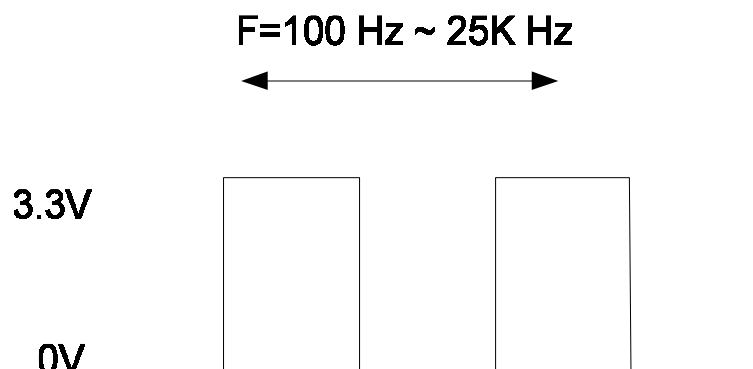

Note 3: DE Mode: Mode="H",HS floating and VS floating.
 HV Mode: Mode="L" and DE floating.

Note 4: Selection of scanning mode

Setting of scan control input		Scanning direction
U/D	L/R	
GND	V _{CC}	Up to down, left to right
V _{CC}	GND	Down to up, right to left
GND	GND	Up to down, right to left
V _{CC}	V _{CC}	Down to up, left to right

Note 5: Scanning direction refer to the figure below.

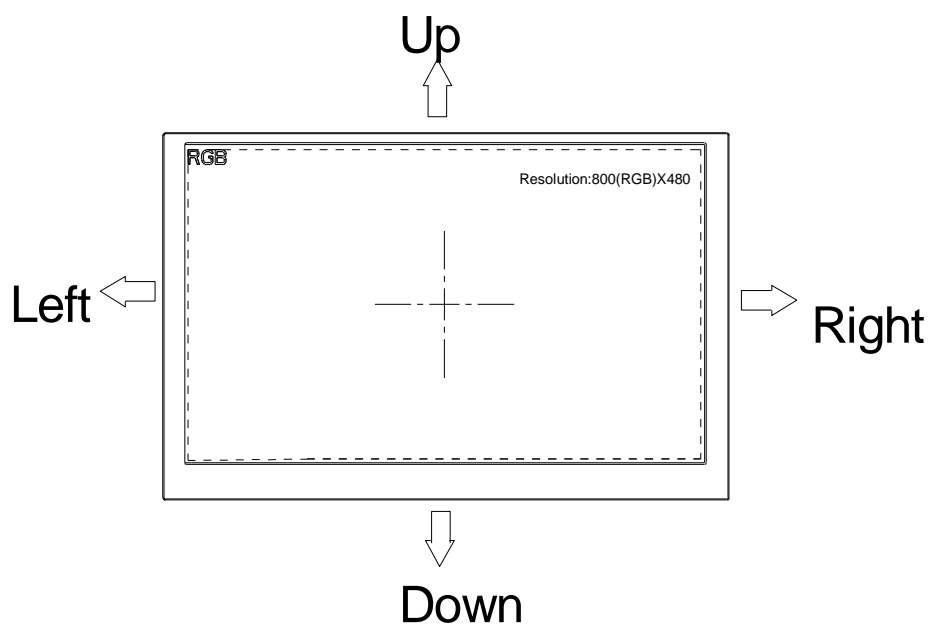

3. Operation Specifications

3.1. Absolute Maximum Ratings

Item	Symbol	Values		Unit	Remark
		Min.	Max.		
Power voltage	V_{CC}	-0.3	6.0	V	
	V_{LED}	-	5.5	V	
Input signal voltage	V_I	-0.3	6.3	V	
Operation Temperature	T_{OP}	-20	70	°C	
Storage Temperature	T_{ST}	-30	80	°C	

Note: The absolute maximum rating values of this product are not allowed to be exceeded at any times. A module should be used with any of the absolute maximum ratings exceeded, the characteristics of the module may not be recovered, or in an extreme condition, the module may be permanently destroyed.

3.2. Typical Operation Conditions

Item	Symbol	Values			Unit	Remark
		Min.	Typ.	Max.		
Power voltage	V_{CC}	3.0	3.3	3.6	V	Note 1
	V_{LED}	4.8	5.0	5.2	V	Note 2
Current consumption	I_{CC}	-	85	120	mA	
	I_{LED}	-	500	550	mA	Note 3
Input logic high voltage	V_{IH}	$0.7V_{CC}$	-	V_{CC}	V	Note 4
Input logic low voltage	V_{IL}	0	-	$0.3V_{CC}$	V	
LED life time	-	20,000	-	-	Hr	Note 5

Note1: V_{CC} setting should match the signals output voltage (refer to Note 4) of customer's system board.

Note 2: LED driving voltage.

Note 3: LED driving current.

Note 4: DCLK, DE, HS, VS, R0~ R5,, G0~ G5, B0~ B5.

Note 5: The "LED life time" is defined as the module brightness decrease to 50% original brightness at $T_a=25^{\circ}\text{C}$ and $V_{LED}=5.0\text{V}$. The LED lifetime could be decreased if operating V_{LED} is larger than 5.0V.

3.3. Power Sequence

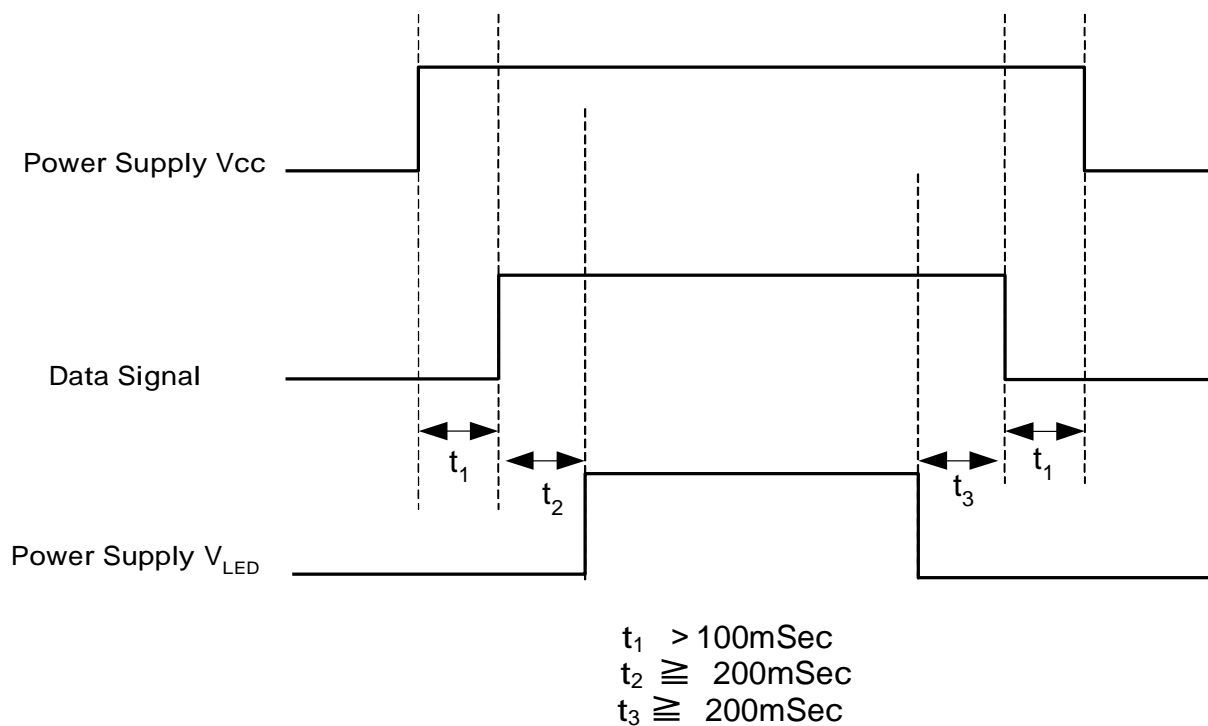

Note: Data Signal includes DCLK, DE, HS, VS, R0~ R5, G0~ G5, B0~ B5.

3.4. Timing Characteristics

3.4.1. AC Electrical Characteristics

Item	Symbol	Values			Unit	Remark
		Min.	Typ.	Max.		
HS setup time	T_{hst}	8	-	-	ns	
HS hold time	T_{hhd}	8	-	-	ns	
VS setup time	T_{vst}	8	-	-	ns	
VS hold time	T_{vhd}	8	-	-	ns	
Data setup time	T_{dsu}	8	-	-	ns	
Data hold time	T_{dhd}	8	-	-	ns	
DE setup time	T_{esu}	8	-	-	ns	
DE hold time	T_{ehd}	8	-	-	ns	
DV _{DD} Power On Slew rate	T_{POR}	-	-	20	ms	From 0 to 90% DV _{DD}
RESET pulse width	T_{Rst}	1	-	-	ms	
DCLK cycle time	T_{coh}	20	-	-	ns	
DCLK pulse duty	T_{cwh}	40	50	60	%	

3.4.2. Input Clock and Data Timing Diagram

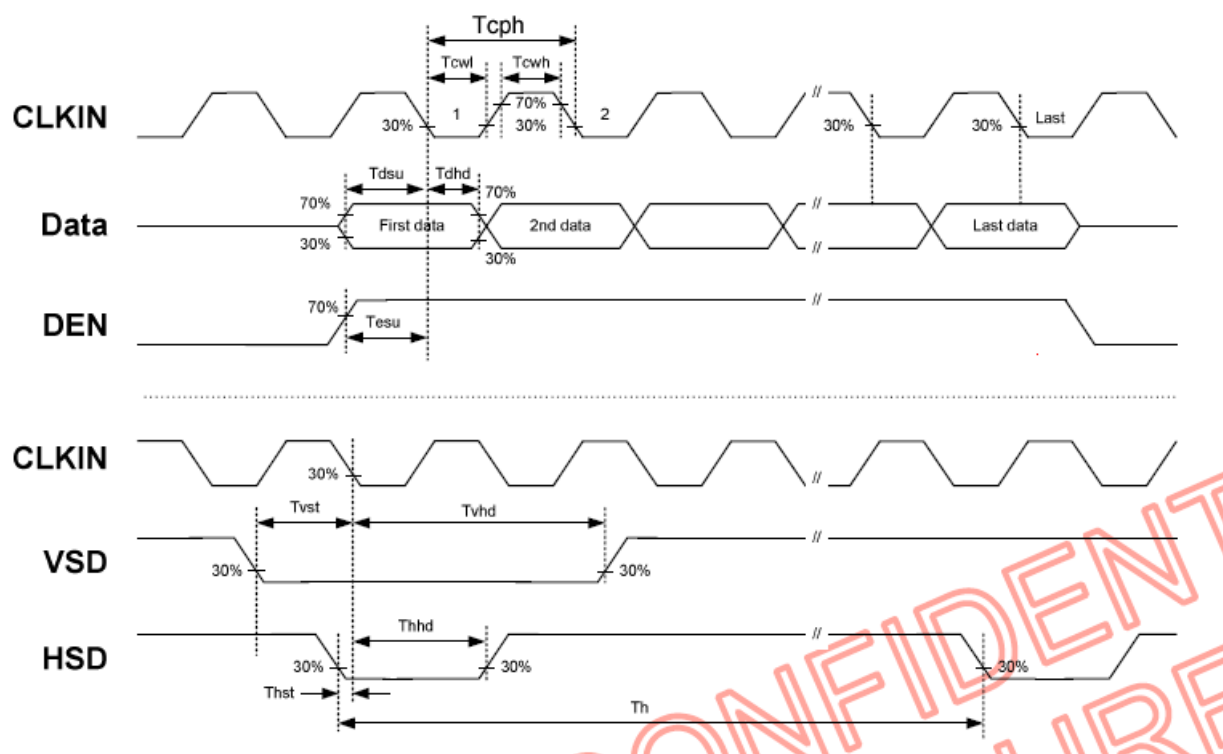

3.4.3. Timing

Item	Symbol	Values			Unit	Remark
		Min.	Typ.	Max.		
Horizontal Display Area	thd	-	800	-	DCLK	
DCLK Frequency	fclk	26.4	33.3	46.8	MHz	
One Horizontal Line	th	862	1056	1200	DCLK	
HS pulse width	thpw	1	-	40	DCLK	
HS Back Porch(Blanking)	thb	46	46	46	DCLK	
HS Front Porch	thfp	16	210	354	DCLK	

Item	Symbol	Values			Unit	Remark
		Min.	Typ.	Max.		
Vertical Display Area	tvd	-	480	-	H	
VS period time	tv	510	525	650	H	
VS pulse width	tvpw	1	-	20	H	
VS Back Porch(Blanking)	tvb	23	23	23	H	
VS Front Porch	tvfp	7	22	147	H	

Note: Frame rate is 60 ± 5 Hz

3.4.4. Data Input Format

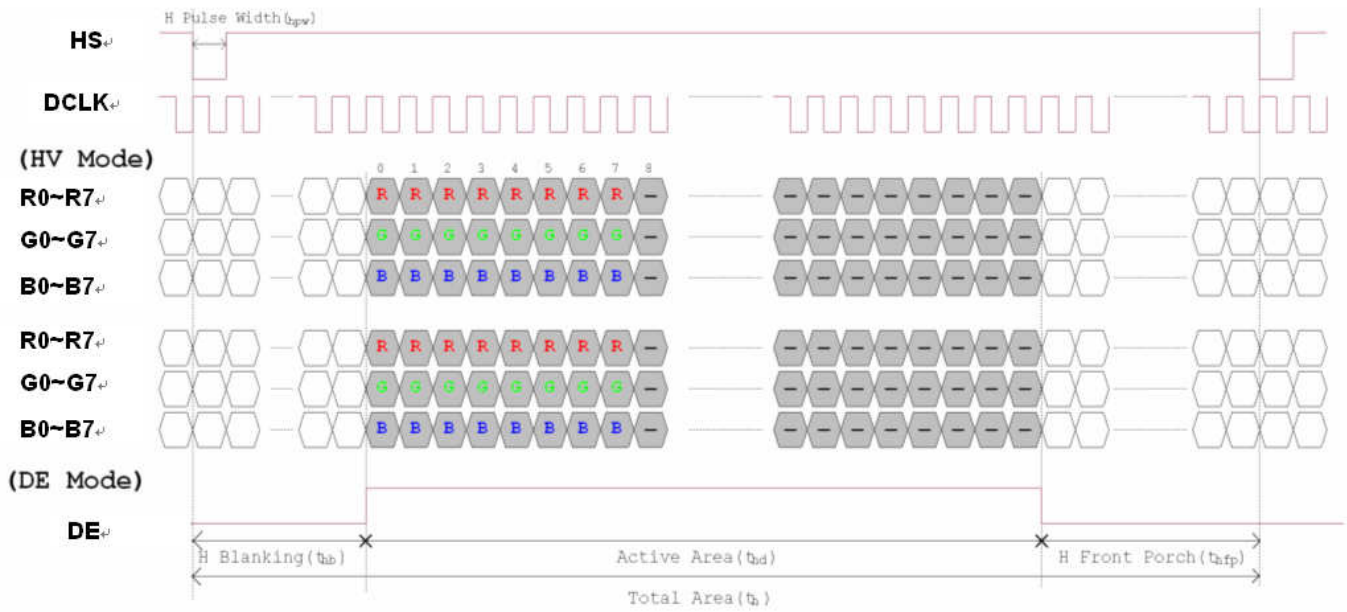

Figure 3. 1 Horizontal input timing diagram.

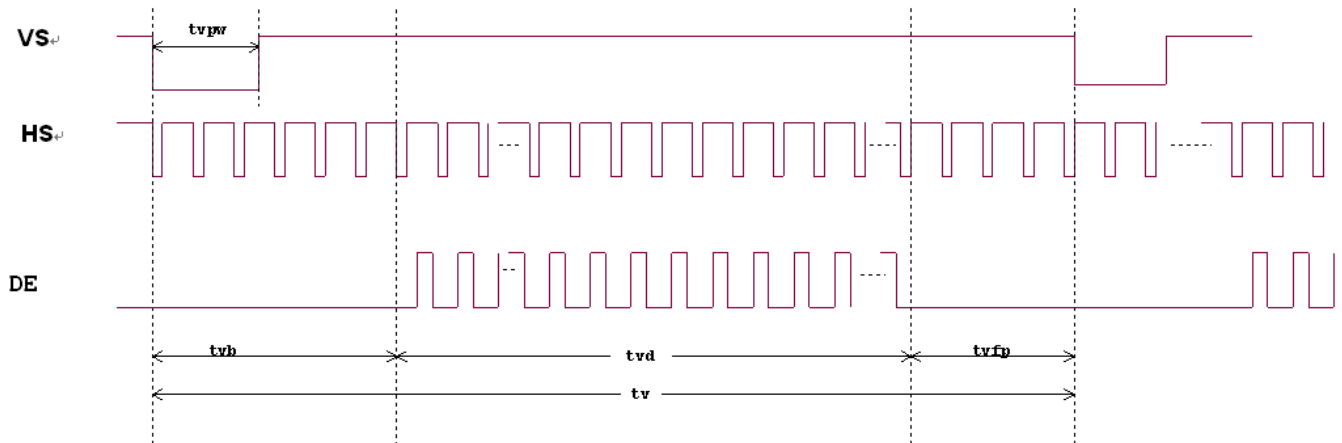

Figure 3. 2 Vertical input timing diagram.

4. Optical Specifications

Item	Symbol	Condition	Values			Unit	Remark
			Min.	Typ.	Max.		
Viewing angle (CR ≥ 10)	θ_L	$\Phi=180^\circ$ (9 o'clock)	60	70	-	degree	Note 1
	θ_R	$\Phi=0^\circ$ (3 o'clock)	60	70	-		
	θ_T	$\Phi=90^\circ$ (12 o'clock)	40	50	-		
	θ_B	$\Phi=270^\circ$ (6 o'clock)	60	70	-		
Response time	$T_{ON+} T_{OFF}$	Normal $\theta=\Phi=0^\circ$	-	25	50	ms	Note 2 Note 3
Contrast ratio	CR		700	1000	-	-	Note 4
Color chromaticity	W_X		0.26	0.31	0.36	-	Note 2 Note 5
	W_Y		0.28	0.33	0.38	-	Note 6
Luminance	L		340	400	-	cd/m ²	Note 6
Luminance uniformity	YU		70	75	-	%	Note 7
Color Saturation (NTSC)	NTSC		Normal $\theta=\Phi=0^\circ$ CLE 1931	45	50	-	%

Test Conditions:

1. $V_{CC}=3.3V$, $V_{LED}=5.0V$. The ambient temperature is 25°C.
2. The test systems refer to Note 2.

Note 1: Definition of viewing angle range

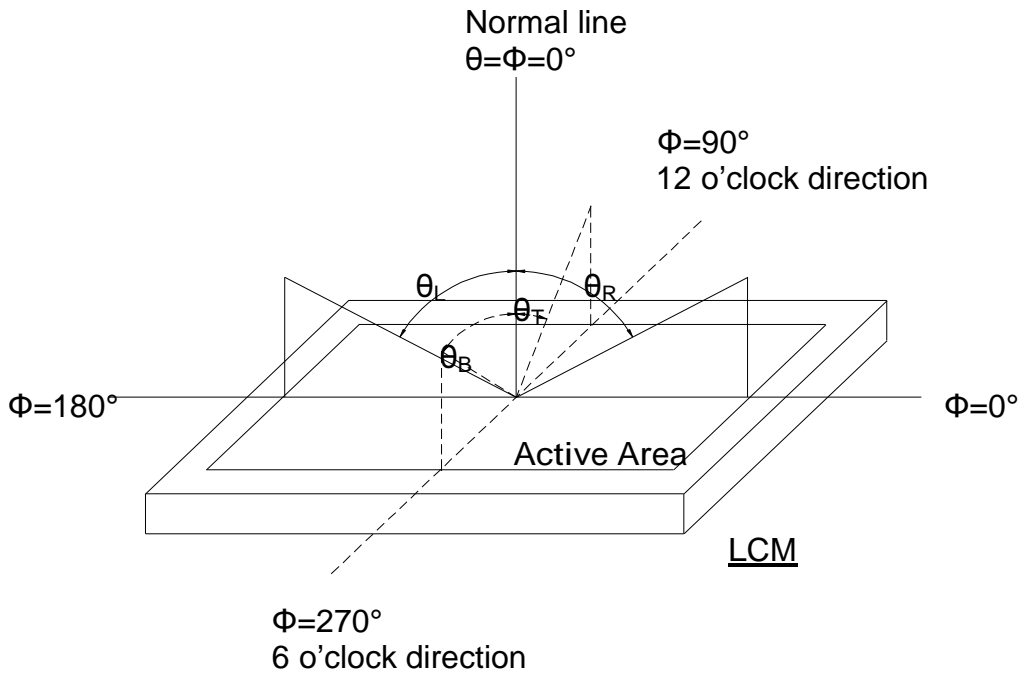

Fig. 4-1 Definition of viewing angle

Note 2: Definition of optical measurement system.

The optical characteristics should be measured in dark room. After 30 minutes operation, the optical properties are measured at the center point of the LCD screen. Optical items are measured by CS2000/Field of view: 1°/Height: 500mm.

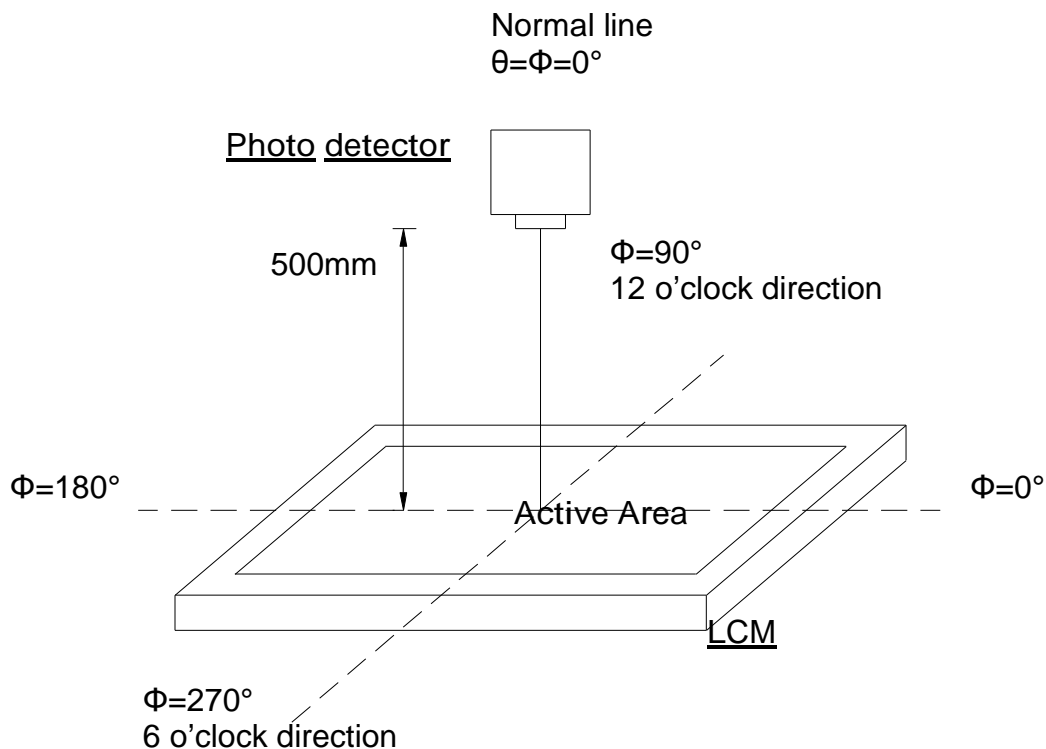

Fig. 4-2 Optical measurement system setup

Note 3: Definition of Response time

The response time is defined as the LCD optical switching time interval between "White" state and "Black" state. Rise time (T_{ON}) is the time between photo detector output intensity changed from 90% to 10%. And fall time (T_{OFF}) is the time between photo detector output intensity changed from 10% to 90%.

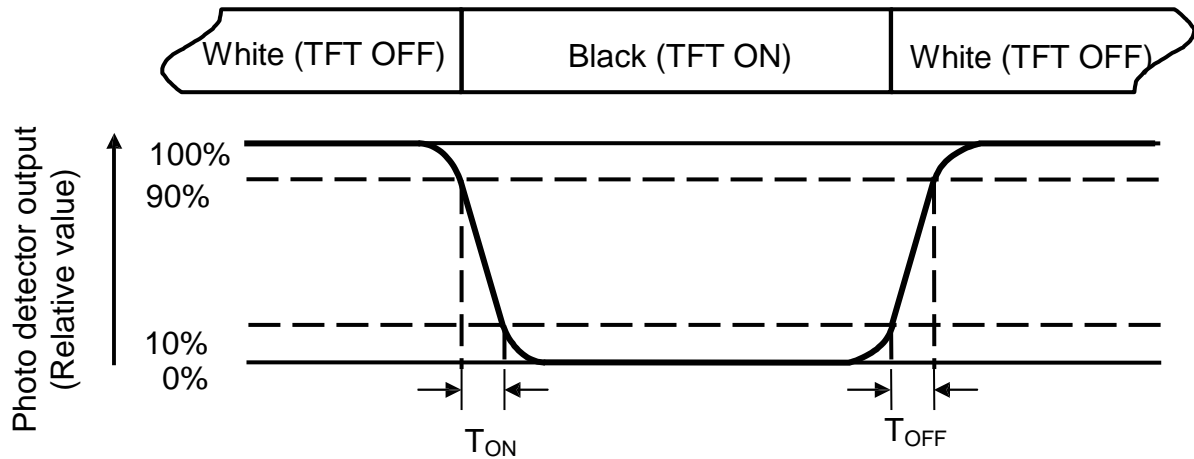

Fig. 4-3 Definition of response time

Note 4: Definition of contrast ratio

$$\text{Contrast ratio (CR)} = \frac{\text{Luminance measured when LCD on the "White" state}}{\text{Luminance measured when LCD on the "Black" state}}$$

Note 5: Definition of color chromaticity (CIE1931)

Color coordinates measured at center point of LCD.

Note 6: All input terminals LCD panel must be ground while measuring the center area of the panel. The LED driving condition is $V_{LED}=5.0V$.

Note 7: Definition of Luminance Uniformity

Active area is divided into 9 measuring areas (Refer to Fig. 4-4).Every measuring point is placed at the center of each measuring area.

$$\text{Luminance Uniformity (Yu)} = \frac{B_{\min}}{B_{\max}}$$

L-----Active area length W----- Active area width

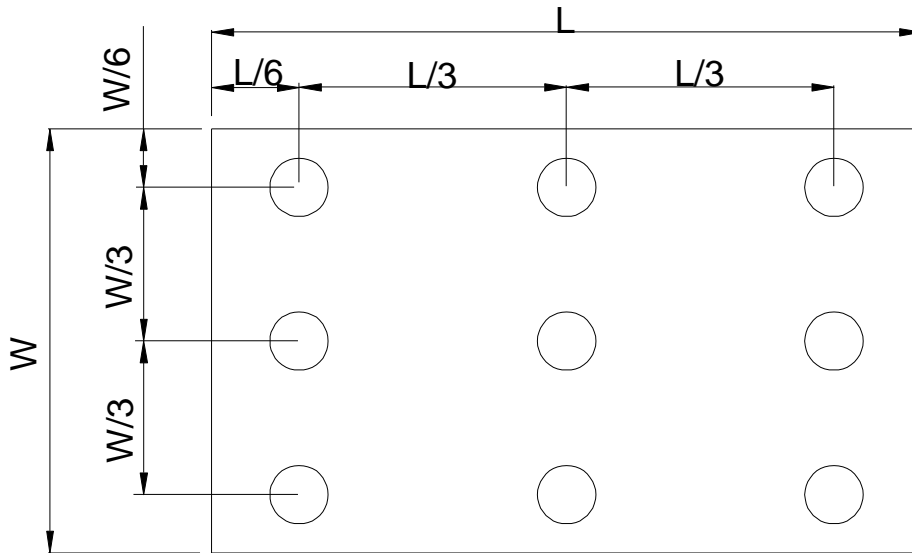

Fig. 4-4 Definition of measuring points

B_{\max} : The measured maximum luminance of all measurement position.

B_{\min} : The measured minimum luminance of all measurement position.

5. Reliability Test Items

Item	Test Conditions			Remark
High Temperature Storage	80°C	240 hrs		Note 1 Note 2 Note 3
Low Temperature Storage	-30°C	240hrs		
High Temperature Operation	70°C	240hrs		
Low Temperature Operation	-20°C	240hrs		
Operate at High Temperature and Humidity	+40°C, 90%RH max.	240 hrs		
Thermal Shock	-30°C/30 min ~ +80°C/30 min for a total 100 cycles, Start with cold temperature and end with high temperature.			
Vibration Test	Frequency: 1.5G / 10-500Hz, 30min/cycle, 1cycle for each X, Y, Z			
Package Vibration Test	1.14Grms Random frequency 1~200Hz 30min/Bottom, 15min/Right-Left, 15min/Front-Back			
Package Drop Test	Height:60 cm 1 corner, 3 edges, 6 surfaces			
Electro Static Discharge	± 2KV, 100pF/1500Ω	Human Body	Mode,	

Note 1: In the standard condition, there shall be no practical problem that may affect the display function. After the reliability test, the product only guarantees operation, but doesn't guarantee all the cosmetic specification.

Note 2: Before cosmetic and function test, the product must have enough recovery time, at least 2 hours at room temperature.

Note3: Under no condensation of dew.

6. General Precautions

6.1. Safety

Liquid crystal is poisonous. Do not put it in your mouth. If liquid crystal touches your skin or clothes, wash it off immediately by using soap and water.

6.2. Handling

1. The LCD panel is plate glass. Do not subject the panel to mechanical shock or to excessive force on its surface.

2. The polarizer attached to the display is easily damaged. Please handle it carefully to avoid scratch or other damages.

3. To avoid contamination on the display surface, do not touch the module surface with bare hands.

4. Keep a space so that the LCD panels do not touch other components.

5. Put cover board such as acrylic board on the surface of LCD panel to protect panel from damages.

6. Transparent electrodes may be disconnected if you use the LCD panel under environmental conditions where the condensation of dew occurs.

7. Do not leave module in direct sunlight to avoid malfunction of the ICs.

6.3. Static Electricity

1. Be sure to ground module before turning on power or operating module.

2. Do not apply voltage which exceeds the absolute maximum rating value.

6.4. Storage

1. Store the module in a dark room where must keep at $25\pm 10^{\circ}\text{C}$ and 65%RH or less.

2. Do not store the module in surroundings containing organic solvent or corrosive gas.

3. Store the module in an anti-electrostatic container or bag.

6.5. Cleaning

1. Do not wipe the polarizer with dry cloth. It might cause scratch.

2. Only use a soft sloth with IPA to wipe the polarizer, other chemicals might permanent damage to the polarizer.



7. Mechanical Drawing

REV	EC NUMBER	DESCRIPTION	DATE
△	XXXXXX	Change PCB outline. Change housing PCB hollow structure. Add up & right side mounting holes. Add connector closed form explain. Add thickness measurement explain.	2022/06/16

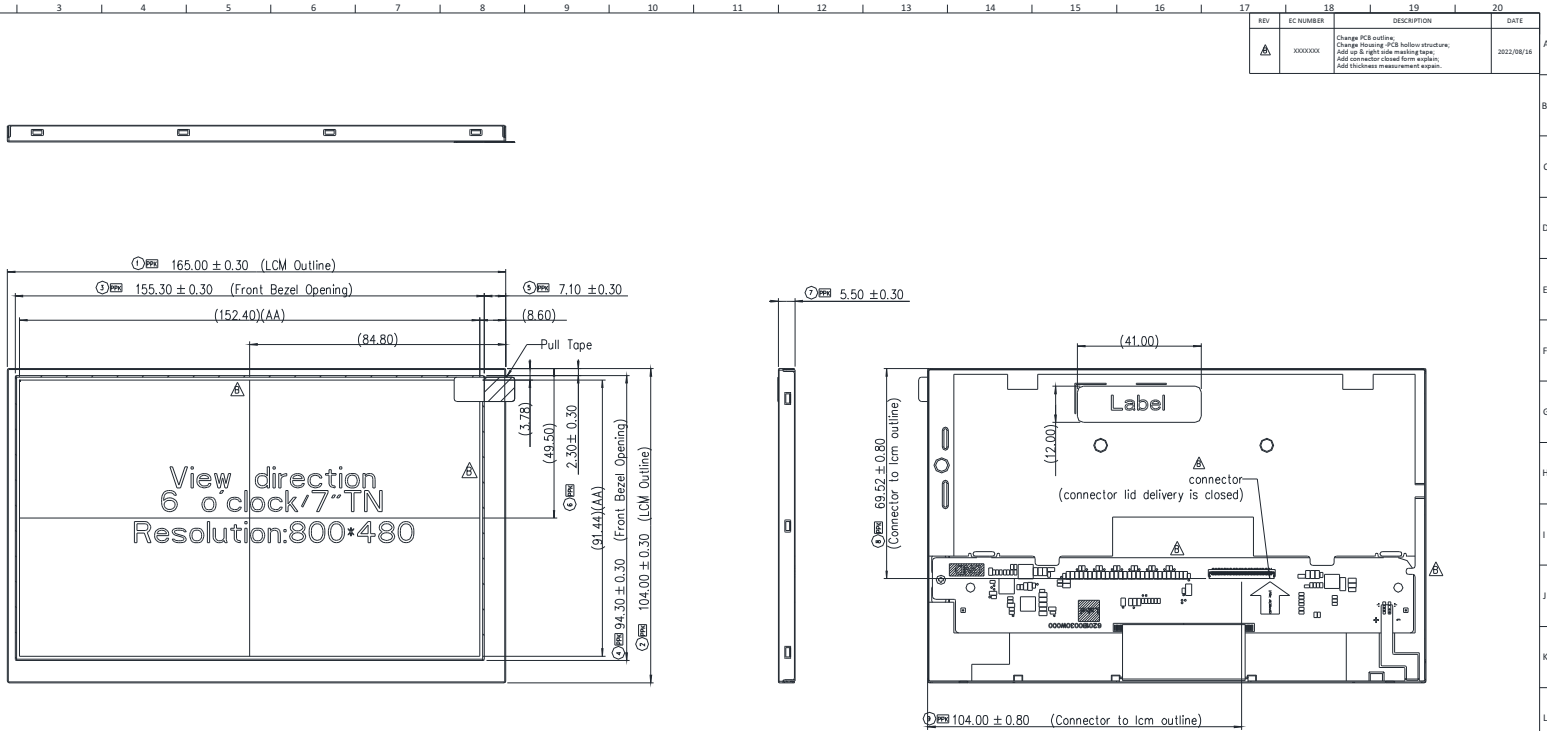

Notes:

1. Display mode: Normally White;
2. Resolution: 800*RGB*480;
3. Pixel pitch: 0.1905*0.1905;
4. View direction: 6 O'Clock;
5. TTL connector: 196534-40041-3 (40 pin);
6. Unspecified tolerance is ±0.3mm;
7. Storage temperature: -30~80;
8. Operating temperature: -20~70;
9. LCM bending must be within 0.5mm Max.
10. Critical dimension (Ⓢ);
11. The thickness is measured using a vernier caliper, not include bending.

Green Product Category	
Green 4	Halogen Free
Safety	See 13QM000020
	See 13QM000092

ITEM NO.	DESCRIPTION	QUANTITY	UNIT	REMARKS
1	LCM	1	PCB	
2

APPROVED	DESIGNED	CHECKED	DATE
Cc01.Chen	Pobonsky.Hu	Xiaonan.Gu	2022/06/16

8. Package Drawing

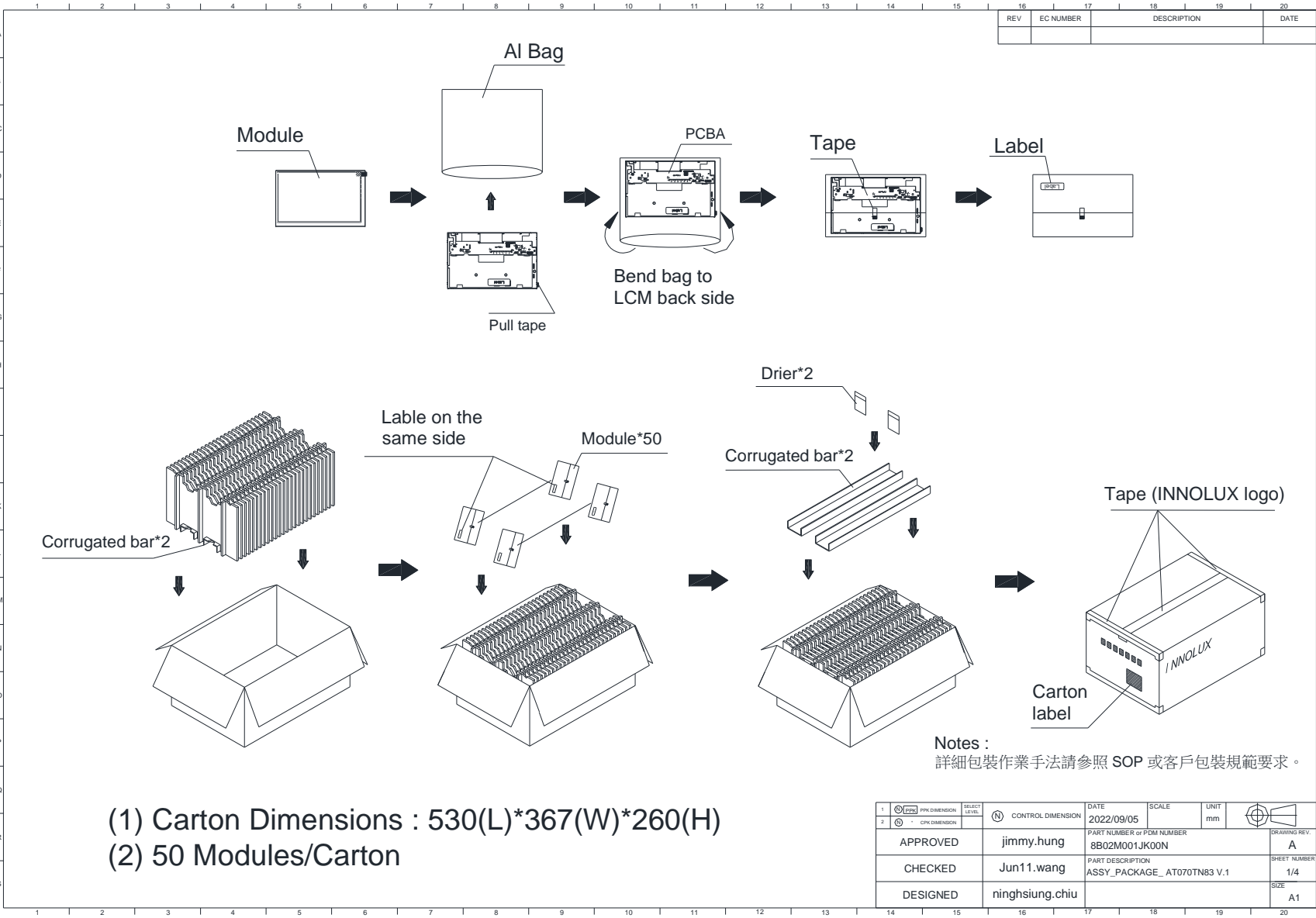

- (1) Carton Dimensions : 530(L)*367(W)*260(H)
- (2) 50 Modules/Carton

REV	EC NUMBER	DESCRIPTION	DATE	SCALE	UNIT	DATE	SCALE	UNIT
1			2022/09/05		mm			
2								

APPROVED	jimmy.hung	PART NUMBER or PDM NUMBER	8B02M001JK00N	DRAWING REV.	A
CHECKED	Jun11.wang	PART DESCRIPTION	ASSY_PACKAGE_AT070TN83 V.1	SHEET NUMBER	1/4
DESIGNED	ninghsiung.chiu			SIZE	A1