

DM-TFT50-434
5.0" IPS 800x480 DISPLAY PANEL
WITH CAPACITIVE TOUCH –LVDS

Contents

1	Revision History
2	Main Features
3	Pin Description
5.1	TFT
5.2	CTP
4	Mechanical Drawing
5	Electrical Characteristics
5.1	DC Electrical Characteristics
5.2	LED Backlight Characteristics
6	Optical Characteristics
7	LVDS Signal Timing Characteristics
7.1	AC Electrical Characteristics
7.2	Timing Table
7.3	LVDS Data Input Format
8	CTP Specification
8.1	Electrical Characteristics
8.2	AC Characteristics
8.3	I2C interface:
9	Reliability
10	Warranty and Conditions

1 Revision History

Date	Changes
2022-05-20	First release

2 Main Features

Item	Specification	Unit
Size	5.0	Inch
Resolution	800(RGB) x 480	pixel
Module Dimension	132.72 x 87.8 x 4.73	mm
Display area	108.0 x 64.8	mm
Pixel pitch	0.135 x 0.135	mm
TFT Controller IC	ST7262	-
CTP Driver IC	GT911	-
Interface	4 Lane LVDS/8bit LVDS	-
Display Color	16.7M	colors
View Direction	All	
Touch mode	Five points and Gestures	-
Display mode	Transmissive / Normally black	-
Weight	95	g

3 Pin Description

5.1 TFT

Pin No.	Symbol	Function Description
1	NC	No connection
2	VDD	Supply voltage(3.3V).
3	VDD	Supply voltage(3.3V).
4	NC	No connection
5	RESET	Reset pin. The chip is in reset state when RESETB=0.
6	STBYB	Display power control PIN. H: Power ON. L: Power OFF. Internal pull down resistor 100K.
7	GND	Ground
8	RXIN0-	- LVDS differential data input
9	RXIN0+	+ LVDS differential data input
10	GND	Ground
11	RXIN1-	- LVDS differential data input
12	RXIN1+	+ LVDS differential data input
13	GND	Ground
14	RXIN2-	- LVDS differential data input
15	RXIN2+	+ LVDS differential data input
16	GND	Ground
17	RXCLKIN-	- LVDS differential clock input
18	RXCLKIN+	+ LVDS differential clock input
19	GND	Ground
20	RXIN3-	- LVDS differential data input
21	RXIN3+	+ LVDS differential data input
22	GND	Ground
23	NC	No connection
24	NC	No connection
25	GND	Ground
26	NC	No connection
27	NC	No connection
28	NC	No connection
29	NC	No connection
30	GND	Ground
31	LED-	LED Cathode
32	LED-	LED Cathode
33	L/R/VDIR	Horizontal shift direction (source output) selection(NOTE1)
34	U/D/HDIR	Vertical shift direction (gate output) selection(NOTE1)
35	XR(NC)	Touch panel Right Glass Terminal
36	YD(NC)	Touch panel Bottom Film Terminal
37	XL(NC)	Touch panel LIFT Glass Terminal
38	YU(NC)	Touch panel Top Film Terminal
39	LED+	LED Anode
40	LED+	LED Anode

NOTE1

L/R	1	Set left to right scan direction
L/R	0	Set right to left scan direction.
U/D	1	Set top to bottom scan direction
U/D	0	Set bottom to top scan direction

5.2 CTP

No.	Symbol	Description
1	GND	Ground
2	VDDIO(NC)	No Connection
3	VDD	Supply voltage
4	SCL	I2C clock input
5	SDA	I2C data input and output
6	INT	External interrupt to the host
7	RST	External Reset, Low is active
8	GND	Ground

4 Mechanical Drawing

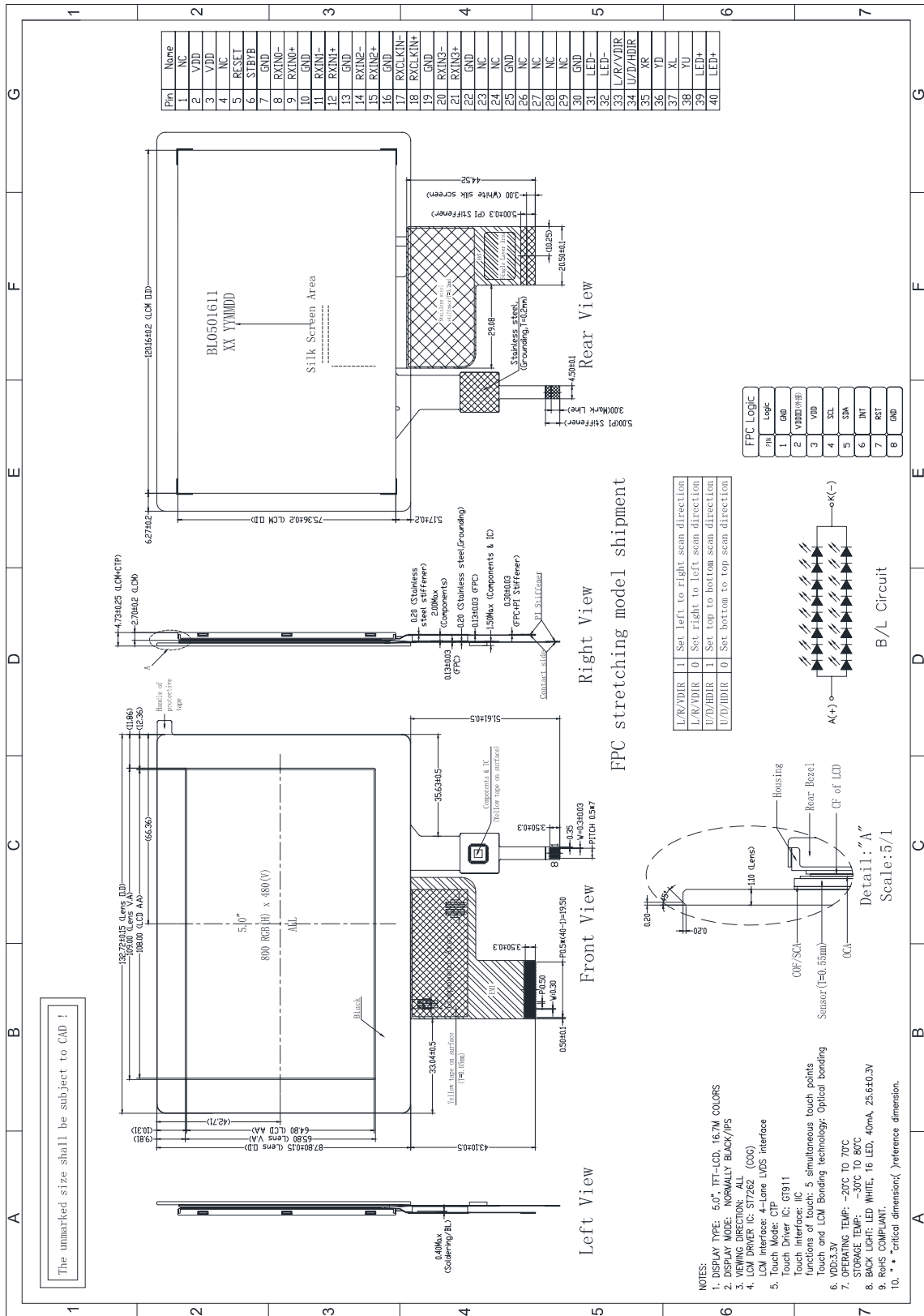

5 Electrical Characteristics

5.1 DC Electrical Characteristics

Item	Symbol	Condition	Min	Typ	Max	Unit
Digital Supply Voltage	VDD		3.0	3.3	3.6	V
Normal mode Current	IDD		-	90	180	mA
Operating Temperature	TOP	Absolute Max	-20	-	+70	°C
Storage Temperature	TST	Absolute Max	-30	-	+80	°C
Storage temperature	VDD	Absolute Max	-0.3	-	4.0	V
LVDS Interface	Differential Input High Threshold Voltage	VLVTH	-	-	100	mV
	Differential Input Low Threshold Voltage	VLVTL	-	-100	-	mV
RGB Interface	VIH	-	2.0	-	VDD	V
	VIL	-	GND	-	0.8	V

5.2 LED Backlight Characteristics

Item	Symbol	Min	Typ	Max	Unit
LED Forward Current	If	30	40	-	mA
LED Forward Voltage	Vf	-	25.6	-	V
View Angles Left	Hr	-	50000	-	Hour
Response Time	Avg	80	-	-	%
LCM Luminance	Lv	600	650	-	cd/m ²

6 Optical Characteristics

Item	Symbol	Min	Typ	Max	Unit
View Angles TOP	θ U	70	80	-	deg
View Angles Bottom	θ D	70	80	-	deg
View Angles Right	θ R	70	80	-	deg
View Angles Left	θ L	70	80	-	deg
Response Time	Tr +Tf		30	40	ms
Contrast Ratio	CR	1000	1500	-	--
Color Gamut	S(%)	55	60	-	%

7 LVDS Signal Timing Characteristics

7.1 AC Electrical Characteristics

Item	Symbol	Min	Typ	Max	Unit	Note
LVDS Differential input high Threshold voltage	RxVTH	-	-	+100	mV	RXVCM=1.2V
LVDS Differential input low Threshold voltage	RxVTL	-100	-	-	mV	
LVDS Differential input common mode voltage	RxVCM	0.7	-	1.6	V	
LVDS Differential voltage	VID	200	-	600	mV	

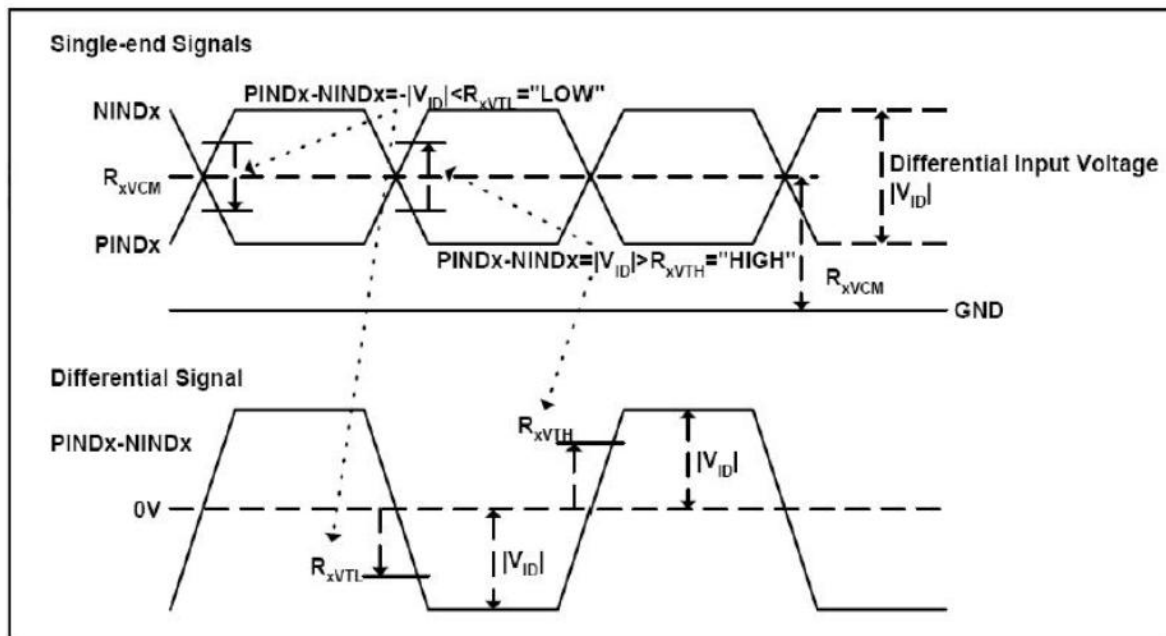

7.2 Timing Table

Parallel 24-bit RGB Interface Timing Table						
Item	Symbol	Min.	Typ.	Max.	Unit	Remark
DCLK Frequency	Fclk	23	25	27	MHz	
HSYNC	Period Time	T_h	808	816	896	DCLK
	Display Period	T_{hdisp}	800		DCLK	
	Back Porch	T_{hbp}	4	8	48	DCLK
	Front Porch	T_{hfp}	4	8	48	DCLK
	Pulse Width	T_{hw}	2	4	8	DCLK
VSYNC	Period Time	T_v	488	496	504	HSYNC
	Display Period	T_{vdisp}	480		HSYNC	
	Back Porch	T_{vbp}	4	8	12	HSYNC
	Front Porch	T_{vfp}	4	8	12	HSYNC
	Pulse Width	T_{vw}	2	4	8	HSYNC

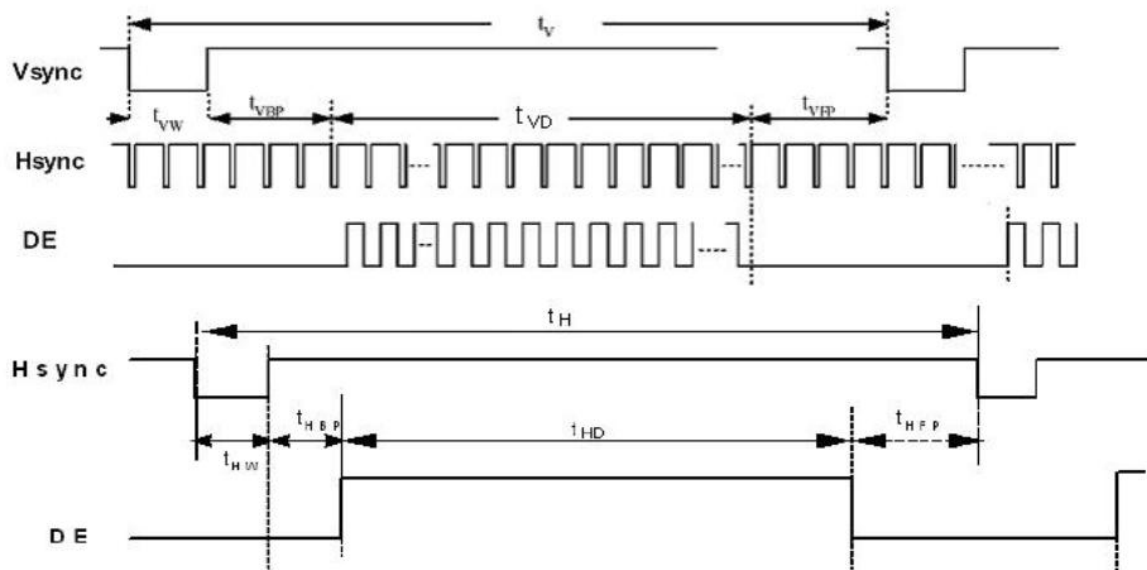

7.3 LVDS Data Input Format

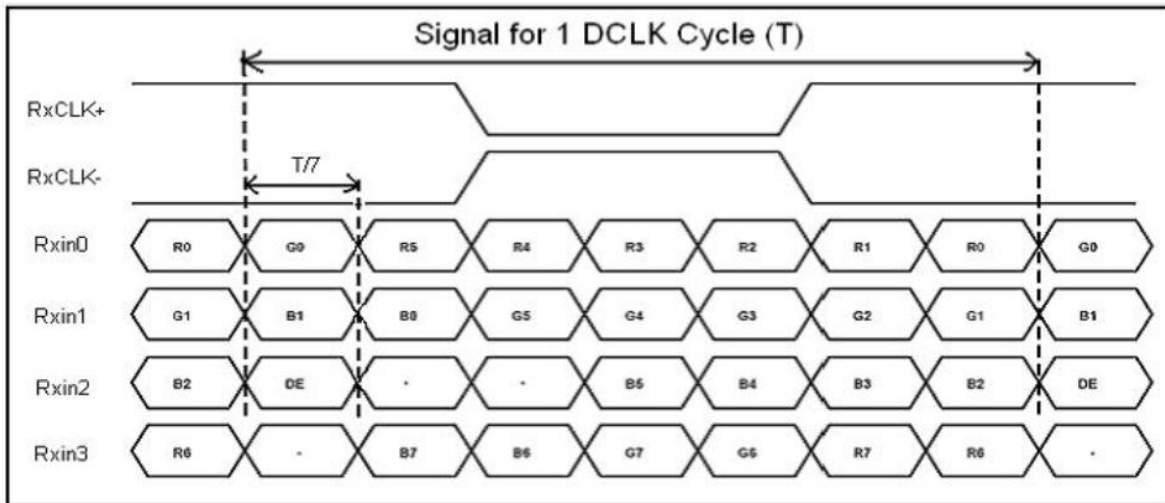

8 CTP Specification

8.1 Electrical Characteristics

Item	Sym bol	Condition	Min	Typ	Max	Unit
Power Supply Voltage	VDD	Absolute Max	2.66	-	3.47	V
Power Supply Voltage	VDD		2.66	3.3	3.47	V
Normal mode Operating Current	-		-	8	14.5	mA
Green mode Operating Current	-		-	3.3	-	mA
Sleep mode Operating Current	-		70	-	120	uA
Doze mode Operating Current	-		-	0.78	-	mA
Digital Input low voltage	VIL		-0.3	-	0.25*VDD	V
Digital Input high voltage	VIH		0.75*VDD	-	VDD+0.3	V
Digital Output low voltage	VOL		-	-	0.15*VDD	V
Digital Output high voltage	VOH		0.85*VDD	-	-	V

(Ambienttemperature:25°C,VDD=2.8V,VDDIO=1.8V or VDDIO=VDD)

8.2 AC Characteristics

Item	Min	Typ	Max	Unit
OSC oscillation frequency	59	60	61	MHz
I/O output rise time,low to high	-	14	-	ns
I/O output rfall time,high to low	-	14	-	ns

(Ambienttemperature:25°C,VDD=2.8V,VDDIO=1.8V)

8.3 I2C interface:

GT911 provides a standard I2C interface for SCL and SDA to communicate with the host. GT911 always serves as slave device in the system with all communication being initialized by the host.

It is strongly recommended that transmission rate be kept at or below 400Kbps. The I2C timing is shown below:

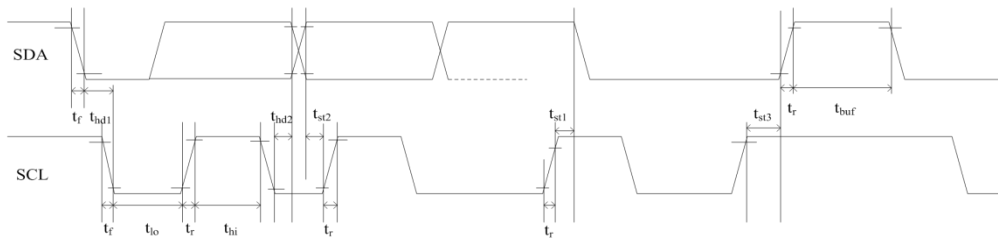

Test condition 1: 1.8V host interface voltage, 400Kbps transmission rate, 2K pull-up resistor

Parameter	Symbol	Min.	Max.	Unit
SCL low period	t_{lo}	1.3	-	us
SCL high period	t_{hi}	0.6	-	us
SCL setup time for Start condition	t_{st1}	0.6	-	us
SCL setup time for Stop condition	t_{st3}	0.6	-	us
SCL hold time for Start condition	t_{hd1}	0.6	-	us
SDA setup time	t_{st2}	0.1	-	us
SDA hold time	t_{hd2}	0	-	us

Test condition 2: 3.3V host interface voltage, 400Kbps transmission rate, 2K pull-up resistor

Parameter	Symbol	Min.	Max.	Unit
SCL low period	t_{lo}	1.3	-	us
SCL high period	t_{hi}	0.6	-	us
SCL setup time for Start condition	t_{st1}	0.6	-	us
SCL setup time for Stop condition	t_{st3}	0.6	-	us
SCL hold time for Start condition	t_{hd1}	0.6	-	us
SDA setup time	t_{st2}	0.1	-	us
SDA hold time	t_{hd2}	0	-	us

9 Reliability

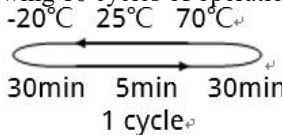
Test Item	Content of Test	Test Condition	Note
High Temperature Storage	Endurance test applying the high storage temperature for a long time.	85°C 200hrs	2
Low Temperature Storage	Endurance test applying the high storage temperature for a long time.	-30°C 200hrs	1,2
High Temperature Operation	Endurance test applying the electric stress (Voltage & Current) and the thermal stress to the element for a long time.	85°C 200hrs	-
Low Temperature Operation	Endurance test applying the electric stress under low temperature for a long time.	-30°C 200hrs	1
High Temperature/ Humidity Operation	The module should be allowed to stand at 60°C,90%RH max, for 96hrs under no-load condition excluding the polarizer. Then taking it out and drying it at normal temperature.	60°C,90%RH 96hrs	1,2
Thermal Shock Resistance	The sample should be allowed stand the following 10 cycles of operation. 	-20°C/70°C 10 cycles	-
Vibration Test	Endurance test applying the vibration during transportation and using.	Total fixed amplitude: 15mm; Vibration: 10~55Hz; One cycle 60 seconds to 3 directions of X, Y, Z, for each 16 minutes.	3
Static Electricity Test	Endurance test apply the electric stress to the terminal.	VS=800V, RS=1.5kΩ, CS=100pF, 1 time.	-

Note1: No dew condensation to be observed.

Note2: The function test shall be conducted after 4 hours storage at the normal. Temperature and humidity after remove from the rest chamber.

Note3: Test performed on product itself, not inside a container

10 Warranty and Conditions

<http://www.displaymodule.com/pages/faq>