



**DM-TFT43-391**  
**4.3" IPS 480x272 HIGH BRIGHTNESS**  
**DISPLAY PANEL –RGB**

## Contents

- 1 Revision History
- 2 Main Features
- 3 Pin Description
  - 3.1 TFT
- 4 Mechanical Drawing
- 5 Optical & Electrical Characteristics
  - 5.1 Optics Characteristics
  - 5.2 Absolute Maximum Ratings
  - 5.3 DC Characteristics
  - 5.4 LED Backlight Characteristics
  - 5.5 AC Characteristics
    - 5.5.1 System Bus Timing for RGB Interfacelock and data characteristics
    - 5.5.2 RGB Interface
    - 5.5.3 RGB Input Timing Table
- 6 Reliability
- 7 Warranty and Conditions

## 1 Revision History

Date	Changes
2019-05-17	First release
2019-07-18	Second release

## 2 Main Features

Item	Specification	Unit
Size	4.3	Inch
Resolution	480(RGB) x 272	pixel
Module Dimension	105.4 x 67.15 x 2.85	mm
Display area	95.04 x 53.86	mm
Pixel pitch	0.198 x 0.198	mm
TFT Controller IC	SC7283	-
Interface	8/24bit RGB	-
Display Color	65K/262K/16.7M	colors
View Direction	FREE	O'clock
Display mode	Transmissive / Normally black	-
Weight	40	g

## 3 Pin Description

### 3.1 TFT

No.	Symbol	Description
1	LEDK	Cathode pin of backlight
2	LEDA	Anode pin of backlight
3	GND	Ground.
4	VDD	Supply voltage(3.3V).
5-12	R0-R7	8-bit digital Red data input
13-20	G0-G7	8-bit digital Green data input
21-28	B0-B7	8-bit digital Blue data input
29	GND	Ground.
30	PCLK	Clock signal; latching data at the falling edge
31	DISP	Display control / standby mode selection. DISP = "Low" : Standby; (Default) DISP = "High" : Normal display
32	HSYNC	Horizontal sync signal; negative polarity
33	VSYNC	Vertical sync signal; negative polarity
34	DE	Data input enable. Active High to enable the data input When not used in SYNC mode, user should connect it to "Low".
35	NC	--
36	GND	Ground.
37	XR(NC)	Touch panel Right Glass Terminal
38	YD(NC)	Touch panel Bottom Film Terminal
39	XL(NC)	Touch panel Left Glass Terminal
40	YU(NC)	Touch panel Top Film Terminal

# 4 Mechanical Drawing

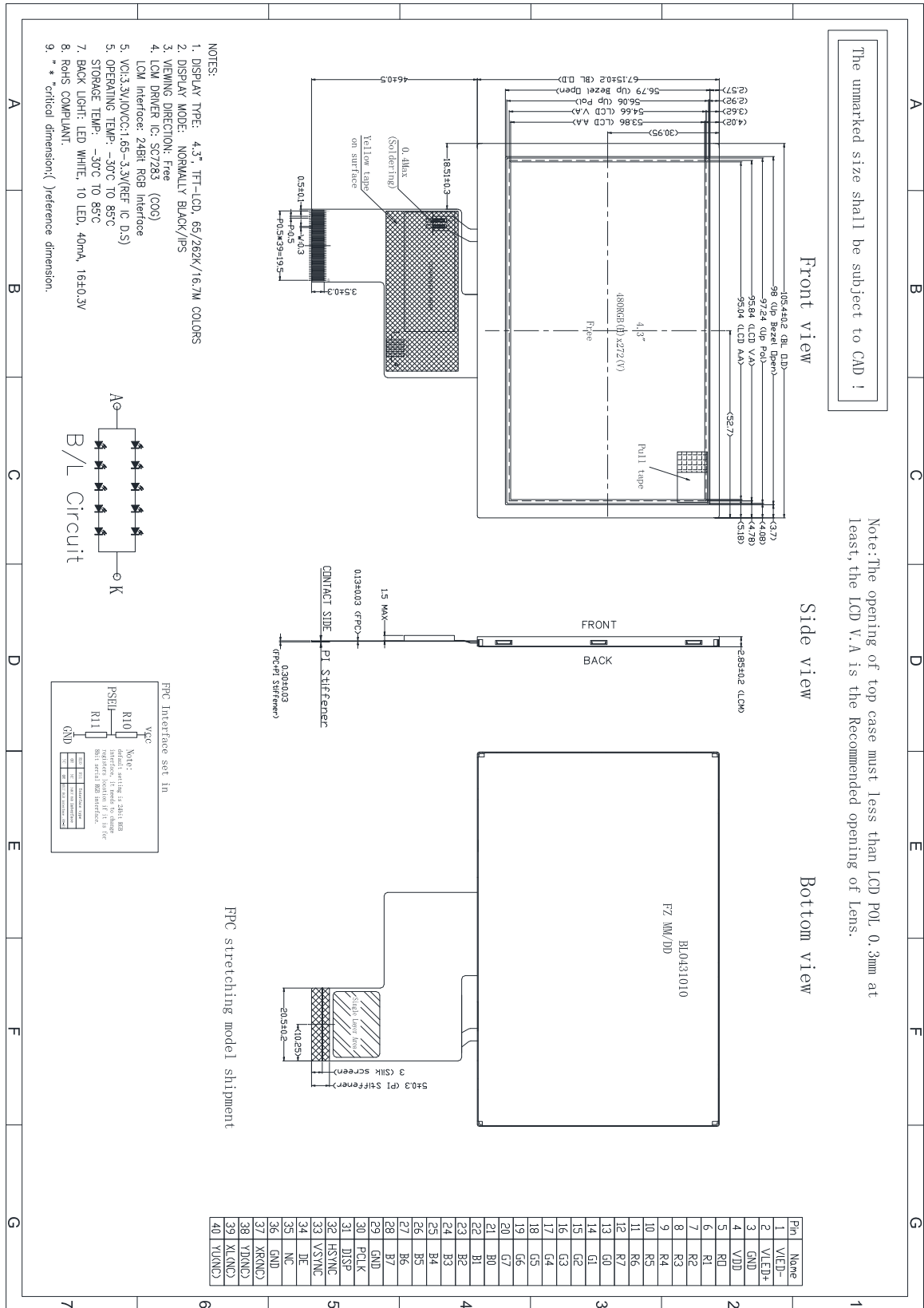

## 5 Optical & Electrical Characteristics

### 5.1 Optics Characteristics

Item	Symbol	Min	Typ	Max	Unit	Remark
View Angles TOP	ΘU	70	80	-	deg	CR ≥ 10
View Angles Bottom	ΘD	70	80	-	deg	
View Angles Right	ΘR	70	80	-	deg	
View Angles Left	ΘL	70	80	-	deg	
C.I.E(Red)	(x)	0.5567	0.5967	0.6367	-	Θ=0 Normal viewing angle
	(y)	0.3211	0.3611	0.4011	-	
C.I.E(Green)	(x)	0.3223	0.3623	0.4023	-	
	(y)	0.5070	0.5470	0.5870	-	
C.I.E(Blue)	(x)	0.1095	0.1495	0.1895	-	
	(y)	0.0752	0.1152	0.1552	-	
C.I.E(White)	(x)	0.2813	0.3213	0.3613	-	
	(y)	0.3126	0.3523	0.3926	-	
Uniformity	S(%)	45	50	-	%	C-light
Response Time	T <sub>R</sub> + T <sub>F</sub>	-	30	40	ms	-
Contrast Ratio	CR	640	800	-	-	-

- Measuring surrounding: dark room
- Ambient temperature: 25±2°C
- 15min. warm-up time

### 5.2 Absolute Maximum Ratings

Item	Symbol	Min	Max	Unit	Remark
Digital Supply Voltage	VDD	-0.3	4.6	V	Note
Operating Temperature	TOP	-30	+85	°C	
Storage Temperature	TST	-30	+85	°C	

Note: If the absolute maximum rating of even is one of the above parameters is exceeded even momentarily, the quality of the product may be degraded. Absolute maximum ratings, therefore, specify the values exceeding which the product may be physically damaged. Be sure to use the product within the range of the absolute maximum ratings.

### 5.3 DC Characteristics

Item	Symbol	Min	Typ	Max	Unit
Digital Supply Voltage	VDD	3.0	3.3	3.6	V
Normal mode Current	IDD	-	23	-	mA
Low Level Input Voltage	V <sub>IL</sub>	GND	-	0.3 x VDD	V
High Level Input Voltage	V <sub>IH</sub>	0.7 x VDD	-	-	V
Low Level Output Voltage	V <sub>OL</sub>	GND	-	GND+0.4	V
High Level Output Voltage	V <sub>OH</sub>	VDD-0.4	-	-	V

## 5.4 LED Backlight Characteristics

Item	Symbol	Min	Typ	Max	Unit	Remark
Forward Current	$I_F$	35	40	-	mA	
Forward Voltage	$V_F$	-	16	-	V	
LCM Luminance ( $I_F=20\text{mA}$ )	LV	850	900	-	cd/m <sup>2</sup>	Note3
LED life time	Hr	50000	-	-	Hour	Note1,2
Uniformity	Avg	80	-	-	%	Note3

The back-light system is edge-lighting type with 10 chips LED.

Note1:LED life time (Hr) can be defined as the time in which it continues to operate under the condition:  $T_a=25\pm 3^\circ\text{C}$ , typical IL value indicated in the above table until the brightness becomes less than 50%.

Note2:The “LED life time” is defined as the module brightness decrease to 50% original brightness at  $T_a=25^\circ\text{C}$  and  $I_L=40\text{mA}$ . The LED lifetime could be decreased if operating  $I_L$  is larger than 40mA. The constant current driving method is suggested.

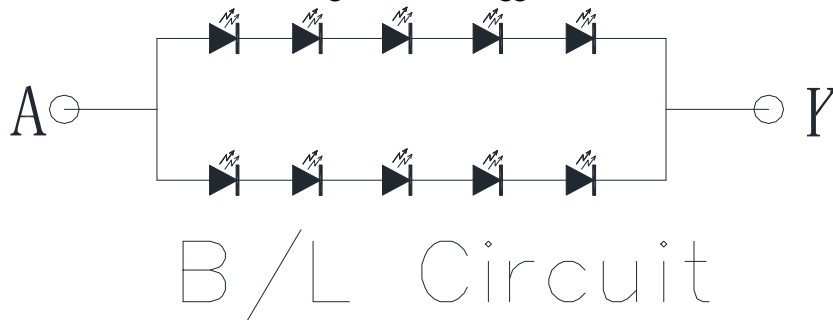

Note3:Luminance Uniformity of these 9 points is defined as below:

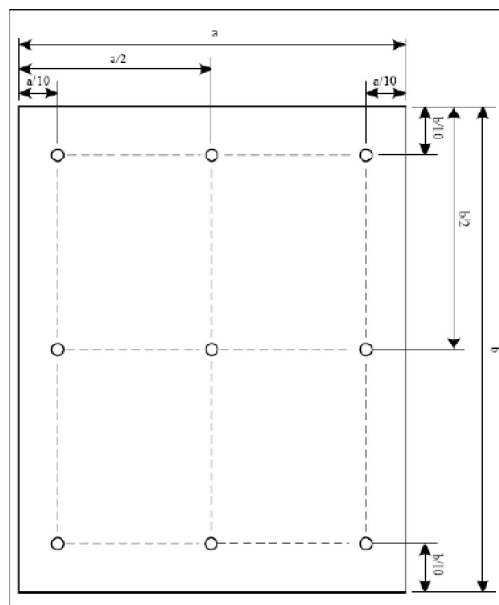

$$\text{Uniformity} = \frac{\text{minimun luminance in 9 point(1 - 9)}}{\text{maximun luminance in 9 point(1 - 9)}}$$

$$\text{Luminance} = \frac{\text{Total Luminance of 9 points}}{9}$$

## 5.5 AC Characteristics

### 5.5.1 System Bus Timing for RGB Interfacelock and data characteristics

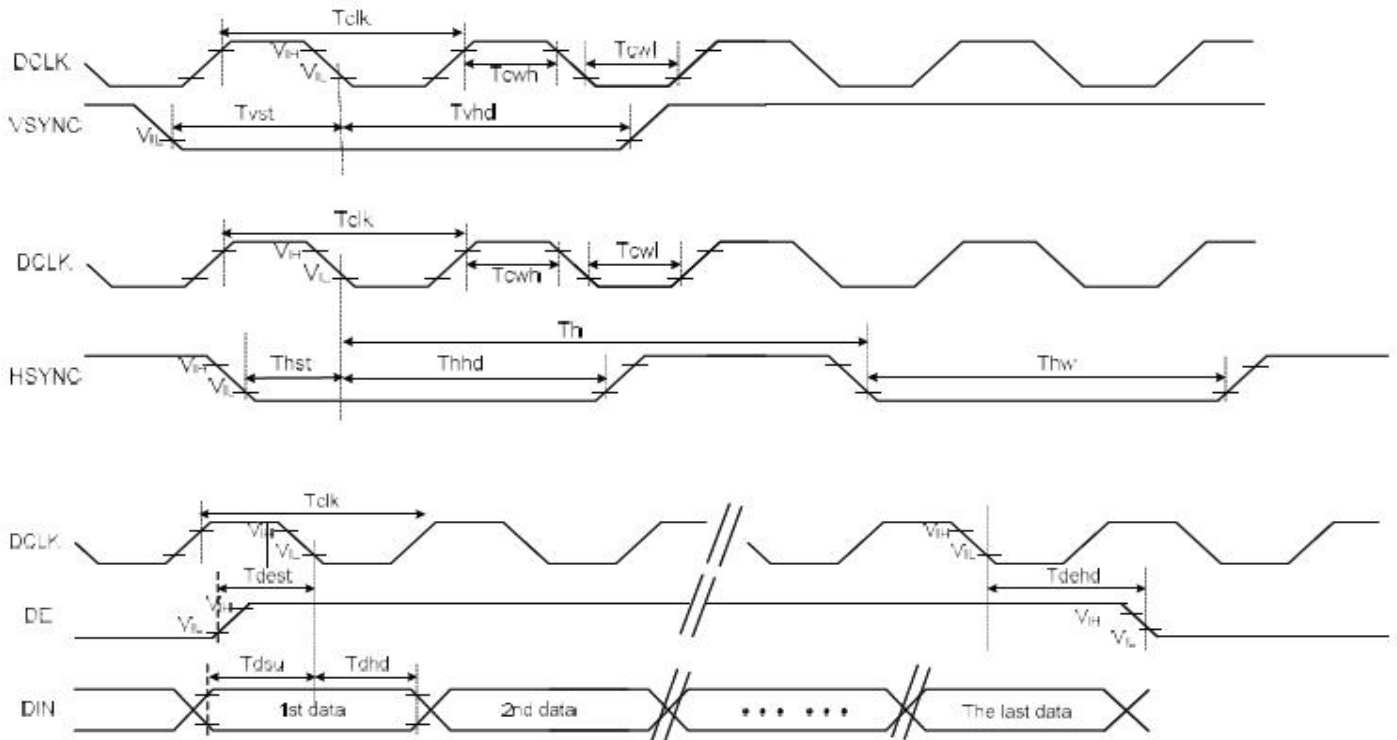

Item	Symbol	Min.	Typ.	Max.	Unit	Conditions
CLK Pulse Duty	$T_{cw}$	40	50	60	%	
HSYNC Width	$T_{hw}$	2	-	-	DCLK	
HSYNC Period	$T_h$	55	60	65	us	
VSYNC Setup Time	$T_{vst}$	12	-	-	ns	
VSYNC Hold Time	$T_{vh}$	12	-	-	ns	
HSYNC Setup Time	$T_{hst}$	12	-	-	ns	
HSYNC Hold Time	$T_{hhd}$	12	-	-	ns	
Data Setup Time	$T_{dsu}$	12	-	-	ns	
Data Hold Time	$T_{dhd}$	12	-	-	ns	
DE Setup Time	$T_{dest}$	12	-	-	ns	
DE Hold Time	$T_{dehd}$	12	-	-	ns	



## 5.5.2 RGB Interface

### SYNC Mode

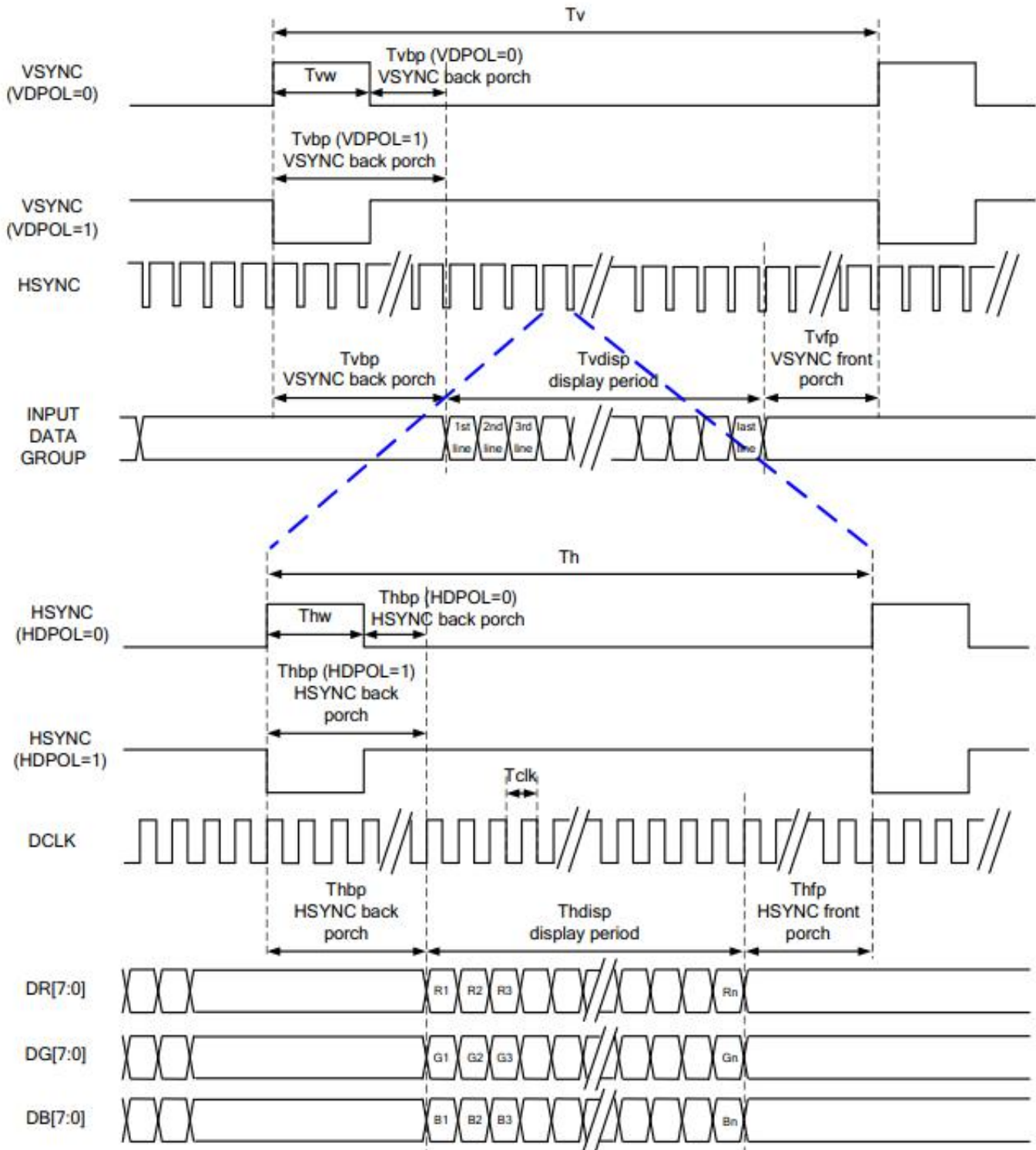

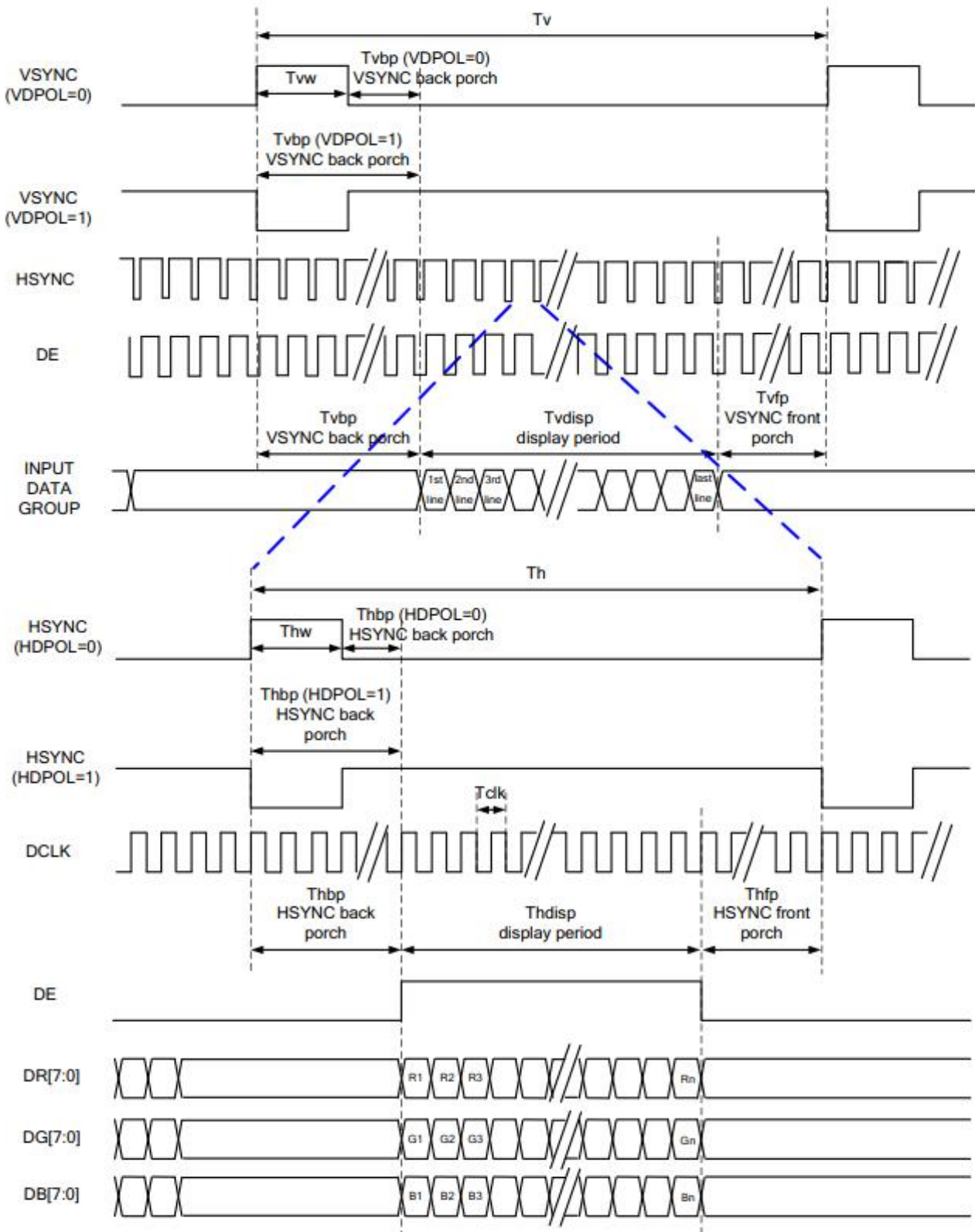
**SYNC-DE Mode**

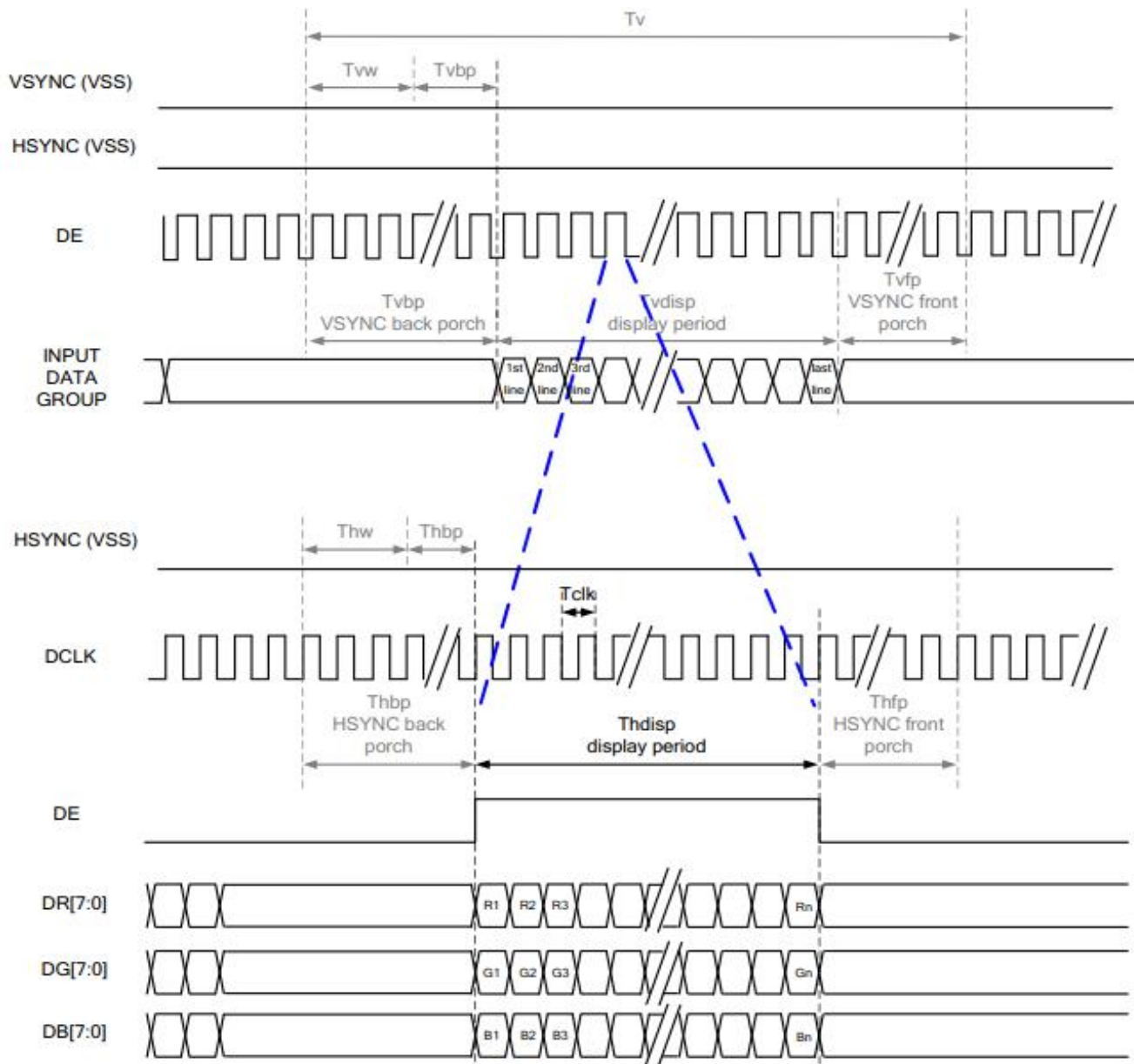
**DE Mode**

RGB Mode Selection Table	DCLK	HSYNC	VSYNC	DE
SYNC - DE Mode	Input	Input	Input	Input
SYNC Mode	Input	Input	Input	GND
DE Mode	Input	GND	GND	Input

Note: "Input" means these signals are driven by host side.

### 5.5.3 RGB Input Timing Table

#### Parallel 24-bit RGB Timing Table

Parallel 24-bit RGB Input Timing (PVDD=VDD=VDDI= 3.3V, AGND= 0V, TA=25°C)

480RGB X 272 Resolution Timing Table							
Item	Symbol	Min.	Typ.	Max.	Unit	Remark	
DCLK Frequency	Fclk	8	9	12	MHz		
DCLK Period	Tclk	83	111	125	ns		
HSYNC	Period Time	Th	485	531	598	DCLK	
	Display Period	Thdisp		480		DCLK	
	Back Porch	Thbp	3	43	43	DCLK	By H_BLANKING setting
	Front Porch	Thfp	2	8	75	DCLK	
	Pulse Width	Thw	2	4	43	DCLK	
VSYNC	Period Time	Tv	276	292	321	HSYNC	
	Display Period	Tvdisp		272		HSYNC	
	Back Porch	Tvbp	2	12	12	HSYNC	By V_BLANKING setting
	Front Porch	Tvfp	2	8	37	HSYNC	
	Pulse Width	Tvw	2	4	12	HSYNC	

Note: It is necessary to keep Tvbp =12 and Thbp =43 in sync mode. DE mode is unnecessary to keep it.

#### Series 8-bit RGB Timing Table

Serial 8-bit RGB Input Timing (PVDD=VDD=VDDI= 3.3V, AGND= 0V, TA=25°C)

480RGB X 272 Resolution Timing Table							
Item	Symbol	Min.	Typ.	Max.	Unit	Remark	
DCLK Frequency	Fclk	24	27	30	MHz		
DCLK Period	Tclk	33	37	42	ns		
HSYNC	Period Time	Th	1445	1491	1558	DCLK	
	Display Period	Thdisp		1440		DCLK	
	Back Porch	Thbp	3	43	43	DCLK	By H_BLANKING setting
	Front Porch	Thfp	2	8	75	DCLK	
	Pulse Width	Thw	2	4	43	DCLK	
VSYNC	Period Time	Tv	276	292	321	HSYNC	
	Display Period	Tvdisp		272		HSYNC	
	Back Porch	Tvbp	2	12	12	HSYNC	By V_BLANKING setting
	Front Porch	Tvfp	2	8	37	HSYNC	
	Pulse Width	Tvw	2	4	12	HSYNC	

Note: It is necessary to keep Tvbp =12 and Thbp =43 in sync mode. DE mode is unnecessary to keep it.

## 6 Reliability

Test Item	Content of Test	Test Condition	Note
High Temperature Storage	Endurance test applying the high storage temperature for a long time.	85°C 96hrs	2
Low Temperature Storage	Endurance test applying the high storage temperature for a long time.	-30°C 96hrs	1,2
High Temperature Operation	Endurance test applying the electric stress (Voltage & Current) and the thermal stress to the element for a long time.	85°C 96hrs	-
Low Temperature Operation	Endurance test applying the electric stress under low temperature for a long time.	-30°C 96hrs	1
High Temperature/ Humidity Operation	The module should be allowed to stand at 60°C,90%RH max, for 96hrs under no-load condition excluding the polarizer. Then taking it out and drying it at normal temperature.	60°C,90%RH 96hrs	1,2
Thermal Shock Resistance	The sample should be allowed stand the following 10 cycles of operation.	-30°C/85°C 20 cycles	-
Vibration Test	Endurance test applying the vibration during transportation and using.	Frequency range:10~55Hz, Stroke:1.5mm Sweep:10Hz~55 Hz~10Hz 2 hours for each direction of X.Y.Z. (6 hours for total) (Package condition).	3
Static Electricity Test	Endurance test apply the electric stress to the terminal.	C=150pF, R=330,5points /panel Air:±8KV, 5times; Contact:±6KV, 5 times; (Environment: 15°C~35°C, 30%~60%).	-

Note1: No dew condensation to be observed.

Note2: The function test shall be conducted after 4 hours storage at the normal. Temperature and humidity after remove from the rest chamber.

Note3: Test performed on product itself, not inside a container

## 7 Warranty and Conditions

<http://www.displaymodule.com/pages/faq>