

DM-TFT28-480-1

2.76" 480 x 480 Round TFT - SPI, RGB

RECORD OF REVISION

Version	Revised Date	Page	Content
V1.0	2022/10/19	--	First Issued

TABLE OF CONTENTS

No.	Content	Page
1.	GENERAL DESCRIPTION	4
2.	MECHANICAL SPECIFICATION	5
3.	PIN DESCRIPTION	6
4.	ABSOLUTE MAXIMUM RATINGS	8
5.	BLOCK DIAGRAM	9
6.	OPTICAL CHARACTERISTICS.....	10
7.	RELIABILITY.....	14
8.	PRECAUTION RELATING PRODUCT HANDLING	19

1. GENERAL DESCRIPTION

1.1 Description

DM-TFT28-480-1 is a 2.8 inch diagonally measured active display with high resolution 480X480 display. This model is composed of a TFT LCD panel, backlight system and HDMI Converter. It is designed to make Raspberry Pi usage easy. You can simply use this display with your Raspberry Pi, or also you can use this as computer display with any device which has HDMI output.

1.2 Features:

No.	Item	Specification	Unit
1	Panel Size	2.76"	Inch
2	Number of Pixels	480 (W) x RGB x 480 (H)	Pixels
3	Active Area	Φ 70.13	mm
4	Pixel Pitch	0.0487 (H) × 0.1461 (V)	mm
5	Outline Dimension	73.03(W) × 76.48 (H) × 2.34(T)	mm
6	Number of Colors	16.7M	--
7	Display Mode	Normally Black / Transmissive	--
8	View Direction	ALL	--
9	Display Format	RGB stripe	--
10	Surface Treatment	/	--
11	Contrast Ratio	1200 (Typ.)	--
12	Luminance (cd/m ²)	380 (Typ.)	cd/m ²
13	Video Input Interface	HDMI (Compliance HDMI 1.4)	--
14	Touch panel	Without CTP	--
15	Backlight	White LED	--
16	Operation Temperature	-20 to 70	°C
17	Storage Temperature	-30 to 80	°C
18	Weight	(TBD)	g

2. MECHANICAL SPECIFICATION

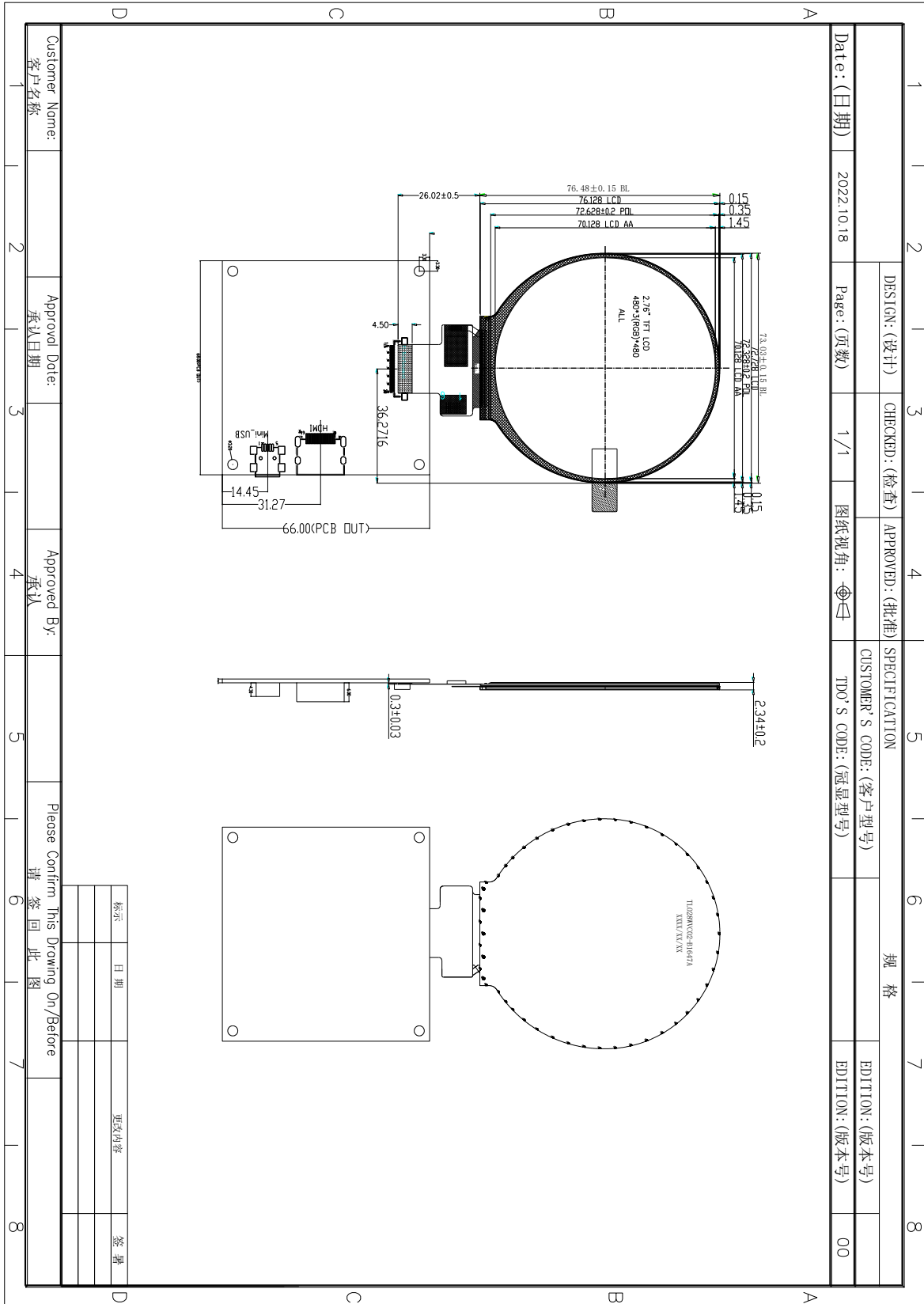

3. PIN DESCRIPTION

3.1 Power Input and HID USB Touch(J2)—Micro USB

Pin No.	Symbol	I/O	Function
1	5V	P	Power Supply +5V, Current Max 620mA
2	USB-	P	DM (HID USB for touch panel)
3	USB+	P	DP (HID USB for touch panel)
4	NC	P	Ground
5	GND	P	Ground

3.2 HDMI (CN1)

[HDMI A TYPE: PHD0911A2301E or compatible]

Pin No.	Symbol	I/O	Function	Note
1	TMDS 2+	I	TMDS Data2+	
2	GND	P	TMDS Data2 Shield	
3	TMDS 2-	I	TMDS Data2-	
4	TMDS 1+	I	TMDS Data1+	
5	GND	P	TMDS Data1 Shield	
6	TMDS 1-	I	TMDS Data1-	
7	TMDS 0+	I	TMDS Data0+	
8	GND	P	TMDS Data0 Shield	
9	TMDS 0-	I	TMDS Data0-	
10	TMDS CLK+	I	TMDS Clock+	
11	GND	P	TMDS Clock Shield	
12	TMDS CLK-	I	TMDS Clock-	
13	CEC	I	CEC	
14	N.C.	-	N.C.	
15	DDC_SCL	I	IIC SCL to EDID ROM	
16	DDC_SDA	I/O	IIC SDA to EDID ROM	
17	GND	P	DDC/CEC Ground	
18	HD_5V	P	+5V Power	
19	HPD	O	Hot Plug Detect	

4. ABSOLUTE MAXIMUM RATINGS

4.1 Electrical Absolute Rating

4.1.1 TFT LCD Module

Item	Symbol	Values		Unit	Note
		Min	Max.		
Power supply voltage	5	4.5	6	V	

4.1.2 Environment Absolute Rating

Item	Symbol	Values			Unit	Note
		Min	Typ	Max.		
Operating Temperature	Top	-20		70	°C	Ambient temperature
Storage Temperature	Tst	-30		80	°C	

5. BLOCK DIAGRAM

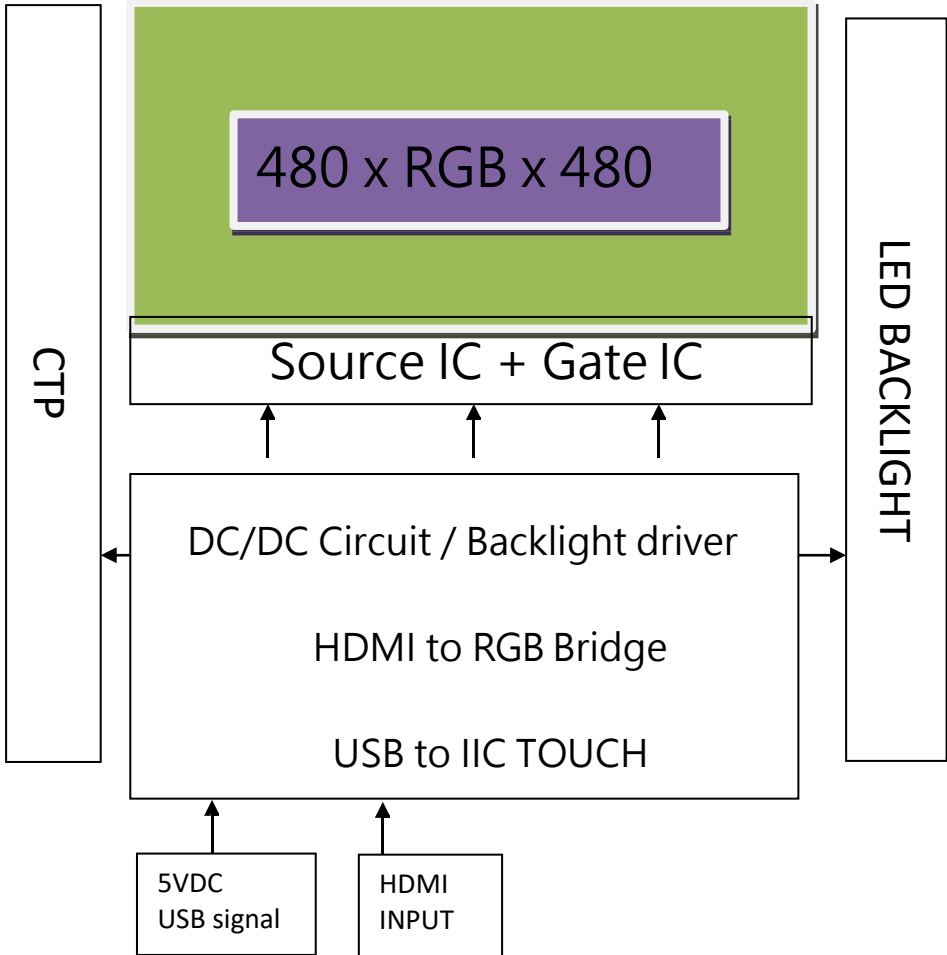

6. OPTICAL CHARACTERISTICS

Item	Symbol	Condition	Min.	Typ.	Max.	Unit	
Brightness	--	Note1, Note 3, ($\theta=0^\circ$, Normal Viewing Angle)		380	--	cd/m ²	
Uniformity	B-uni		75	80	-	%	
Contrast Ratio	CR		1200	1200	--	--	
Response Time	Tr		--	35	40	ms	
	Tf		--	35	40	ms	
Chromaticity	White		Wx	0.268	0.298	0.328	--
			Wy	0.297	0.327	0.357	--
	Red		Wx	0.617	0.647	0.677	
			Wy	0.283	0.313	0.343	
	Green		Wx	0.233	0.263	0.293	
			Wy	0.530	0.560	0.590	
	Blue		Wx	0.107	0.137	0.167	
			Wy	0.076	0.106	0.1361	
View angle	Horizontal	θ_{x+}	80	85	--	degree	
		θ_{x-}	80	85	--	degree	
	Vertical	θ_{Y+}	80	85	--	degree	
		θ_{Y-}	80	85	--	degree	

Note: The following optical specifications shall be measured in a darkroom or equivalent state (ambient luminance ≤ 1 lux, and at room temperature). The operation temperature is $25^\circ\text{C} \pm 2^\circ\text{C}$. The measurement method is shown in Note1.

Note1: The method of optical measurement:

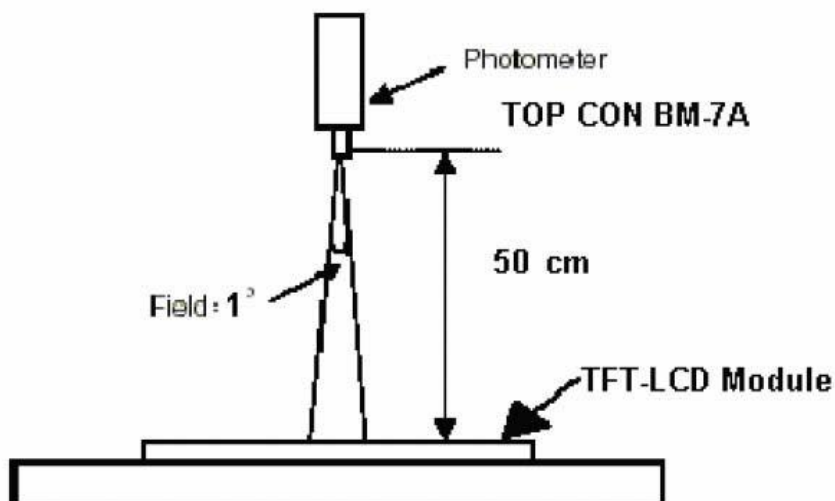

Note2: Measured at the center area of the panel and at the viewing angle of the $\theta_x=\theta_y=0^\circ$

Note3: Definition of Contrast Ratio (CR):

CR = Luminance with all pixels in white state \div Luminance with all pixels in Black state

Note 4: Definition of Viewing Angle:

Note 5: Definition of Brightness Uniformity (B-uni):

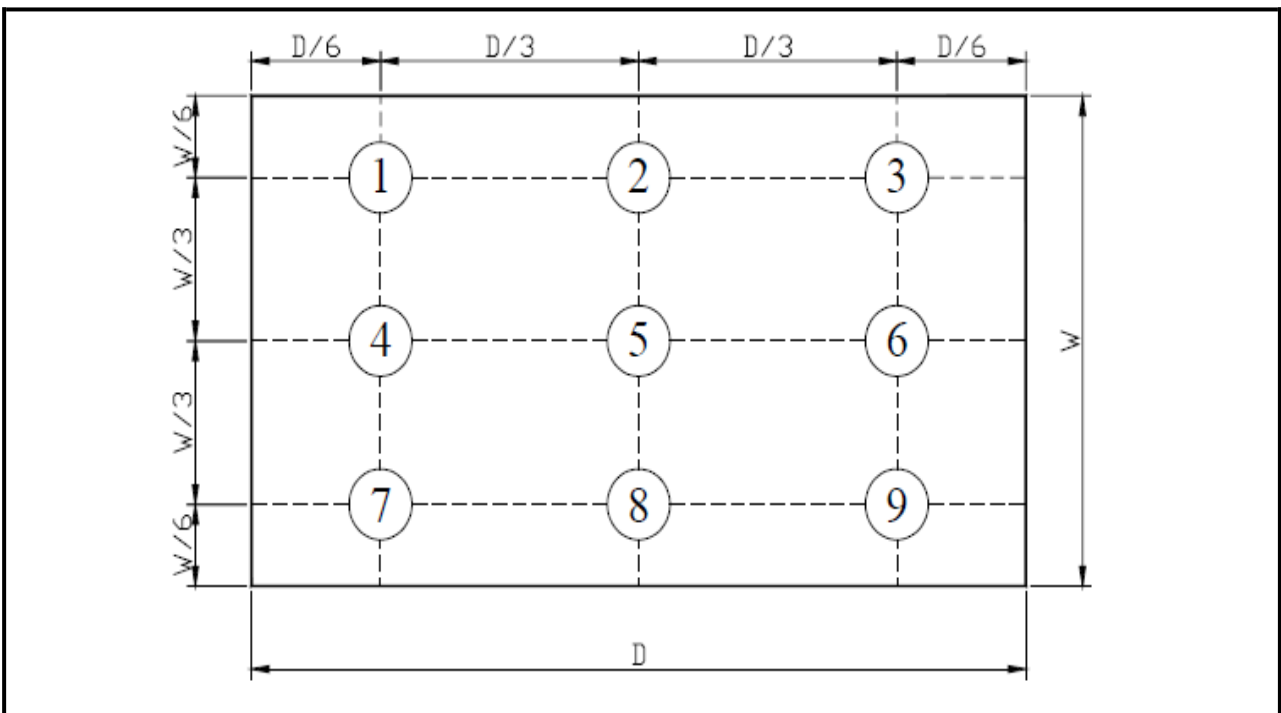
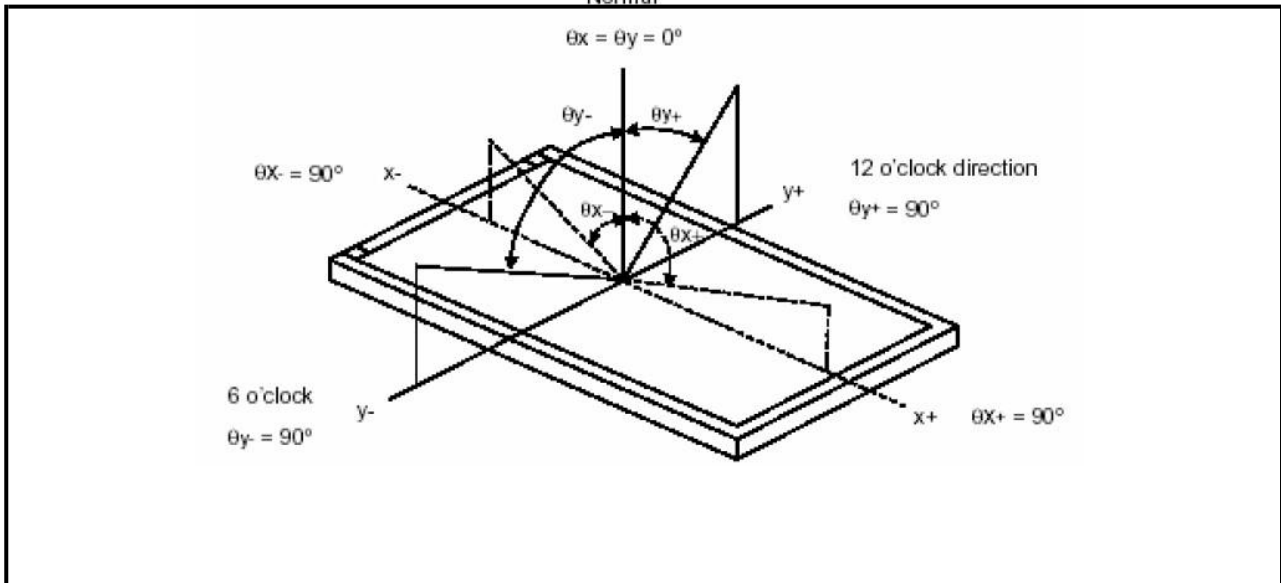

B-uni = (Minimum luminance of 9 points ÷ Maximum luminance of 9 points) X 100%

Note 6: Definition of Response Time:

The Response Time is set initially by defining the “Rising Time (T_r)” and the “Falling Time (T_f)” respectively. T_r and T_f are defined as following figure

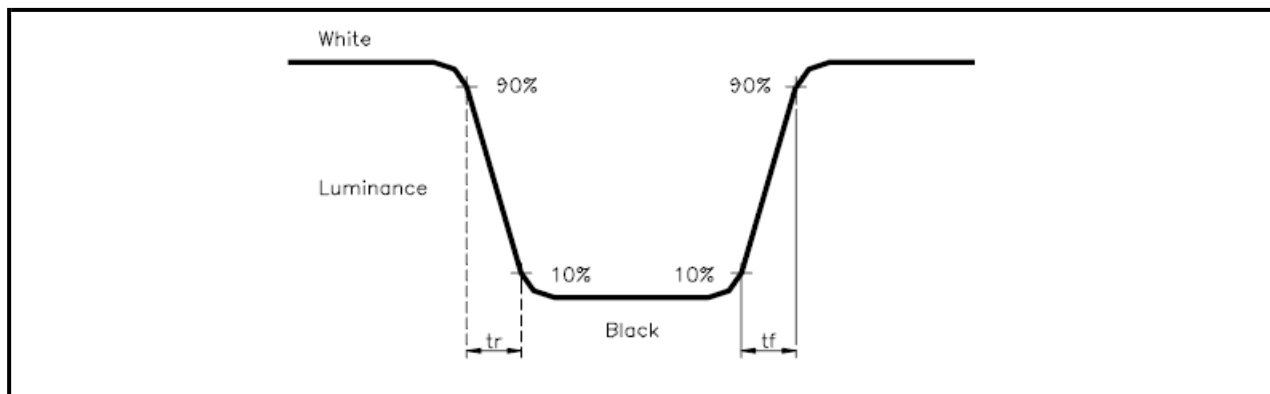
**Note 7: Definition of Chromaticity:**

The color coordinates (W_x , W_y), (R_x , R_y), (G_x , G_y), and (B_x , B_y) are obtained with all pixels in the viewing field at white, red, green, and blue states, respectively.

7. RELIABILITY

7.1 Test Condition

7.1.1 Temperature and Humidity (Ambient Temperature)

Temperature: $20 \pm 5^{\circ}\text{C}$

Humidity: $70 \pm 5\%$

7.1.2 Operation

Unless specified otherwise, test will be conducted under function state.

7.1.3 Container

Unless specified otherwise, vibration test will be conducted to the product itself without putting it in a container.

7.1.4 Test Frequency

In case of related to deterioration such as shock test. It will be conducted only once.

7.2 TESTS

No.	ITEM	CONDITION CRITERION
1	High Temperature Storage	80°C , 240 hrs
2	Low Temperature Storage	-30°C , 240 hrs
3	High Temperature Operating	70°C , 240 hrs
4	Low Temperature Operating	-20°C , 240 hrs
5	High Temperature/Humidity Non-Operating	40°C , 90%RH, 120 hrs
6	Temperature Shock Non-Operating	-30°C 30 min ~ $+70^{\circ}\text{C}$ 30 min, Change time: 0.5 hour ← 5 min → 0.5 hour.10 Cycle
7	Vibration Test Non-Operating	Frequency:0 ~ 55 Hz Amplitude:1.5 mm Sweep Time:11min Test Period:6 Cycles for each Direction of X,Y,Z
8	Electro-static Discharge	C=150pF, R=330Ω, 5point/panel Air: $\pm 8\text{Kv}$, 5 times; Contact: $\pm 4\text{Kv}$, 5times (Environment: $15^{\circ}\text{C} \sim 35^{\circ}\text{C}$, $30\% \sim 60\%$.86Kpa~106Kpa)

Note1: The test sample have recovery time for 24 hours at room temperature before the function

check. In the standard conditions, there is no any touch panel function NG issue occurred.

7.3 JUDGMENT STANDARD

The judgment of the above test should be made as follow:

Pass: Normal display image with no obvious non-uniformity and no line defect. Partial transformation of the module parts should be ignored.

Fail: No display image, obvious non-uniformity, or line defects.

7.4 INCOMING INSPECTION STANDARDS

No.	Parameter	Criteria									
1	Operating	Display function: No Display malfunction (Major)									
		Contrast ratio (Black, White): Does not meet specified range in the spec. (Major) (Note:3)									
		Line Defect: No obvious Vertical and Horizontal line defect in bright, dark and colored. (Major) (Note:1)									
		Point Defect : Active area ≤ 5 dots (Minor) (Note:1)									
		<table border="1"> <thead> <tr> <th rowspan="2">Item</th> <th>Acceptable number</th> <th rowspan="2">Total</th> </tr> <tr> <th>Active Area</th> </tr> </thead> <tbody> <tr> <td>Bright</td> <td>2</td> <td rowspan="2">5</td> </tr> <tr> <td>Dark</td> <td>4</td> </tr> </tbody> </table>	Item	Acceptable number	Total	Active Area	Bright	2	5	Dark	4
		Item		Acceptable number		Total					
			Active Area								
		Bright	2	5							
		Dark	4								
		Non-uniformity: Visible through 5%ND filter. (Minor)									
Foreign material in Black or White spots shape ($W > 1/4L$)											
<table border="1"> <thead> <tr> <th>Zone Dimension</th> <th>Acceptable number</th> <th rowspan="4">Class Of Defects</th> <th rowspan="4">AQL Level</th> </tr> </thead> <tbody> <tr> <td>$D > 0.5$</td> <td>0</td> </tr> <tr> <td>$0.3 < D \leq 0.5$</td> <td>5</td> </tr> <tr> <td>$D \leq 0.3$</td> <td>*</td> </tr> </tbody> </table>	Zone Dimension	Acceptable number	Class Of Defects	AQL Level	$D > 0.5$	0	$0.3 < D \leq 0.5$	5	$D \leq 0.3$	*	
Zone Dimension	Acceptable number	Class Of Defects			AQL Level						
$D > 0.5$	0										
$0.3 < D \leq 0.5$	5										
$D \leq 0.3$	*										
$D = (\text{Long} + \text{Short}) / 2$ * : Disregard											
Foreign Material in Line or spiral shape ($W \leq 1/4L$) (Note: 4)											
<table border="1"> <thead> <tr> <th>L (mm) \ Zone W(mm)</th> <th>Acceptable number</th> <th rowspan="4">Class Of Defects</th> <th rowspan="4">AQL Level</th> </tr> </thead> <tbody> <tr> <td>$L > 5$ $W > 0.1$</td> <td>0</td> </tr> <tr> <td>$0.5 < L \leq 5$ $0.03 < W \leq 0.1$</td> <td>5</td> </tr> <tr> <td>$L \leq 0.5$ $W \leq 0.03$</td> <td>*</td> </tr> </tbody> </table>	L (mm) \ Zone W(mm)	Acceptable number	Class Of Defects	AQL Level	$L > 5$ $W > 0.1$	0	$0.5 < L \leq 5$ $0.03 < W \leq 0.1$	5	$L \leq 0.5$ $W \leq 0.03$	*	
L (mm) \ Zone W(mm)	Acceptable number	Class Of Defects			AQL Level						
$L > 5$ $W > 0.1$	0										
$0.5 < L \leq 5$ $0.03 < W \leq 0.1$	5										
$L \leq 0.5$ $W \leq 0.03$	*										
L : Length W : Width * : Disregard											
2	External Inspection (non-operating)	Dimension: Outline (Major)									
		Bezel appearance: uneven (Minor)									
		Scratch on the polarize: (Note:2)									
		<table border="1"> <thead> <tr> <th>L (mm) \ Zone W(mm)</th> <th>Acceptable number</th> <th rowspan="3">Class Of Defects</th> <th rowspan="3">AQL Level</th> </tr> </thead> <tbody> <tr> <td>-- $W > 0.1$</td> <td>0</td> </tr> <tr> <td>$L \leq 3$ $W \leq 0.1$</td> <td>3</td> </tr> </tbody> </table>	L (mm) \ Zone W(mm)	Acceptable number	Class Of Defects	AQL Level	-- $W > 0.1$	0	$L \leq 3$ $W \leq 0.1$	3	
		L (mm) \ Zone W(mm)	Acceptable number	Class Of Defects			AQL Level				
		-- $W > 0.1$	0								
		$L \leq 3$ $W \leq 0.1$	3								
L : Length W : Width * : Disregard											
Dent or bubble on the polarize (Note:2)											
<table border="1"> <thead> <tr> <th>Zone Dimension</th> <th>Acceptable number</th> <th rowspan="3">Class Of Defects</th> <th rowspan="3">AQL Level</th> </tr> </thead> <tbody> <tr> <td>$D \leq 0.3$</td> <td>*</td> </tr> <tr> <td>$D \leq 0.5$</td> <td>3</td> </tr> </tbody> </table>	Zone Dimension	Acceptable number	Class Of Defects	AQL Level	$D \leq 0.3$	*	$D \leq 0.5$	3			
Zone Dimension	Acceptable number	Class Of Defects			AQL Level						
$D \leq 0.3$	*										
$D \leq 0.5$	3										
$D = (\text{Long} + \text{Short}) / 2$ * : Disregard											

Class of defects			Definition
	Major	AQL 0.65%	
Minor	AQL 1.5%		It is a defect that will not result in functioning problem with deviation classified.

Note1:

(a) Bright point defect is defined as point defect of R,G,B with area $>1/2$ pixel respectively (b) Dark point defect is defined as visible in full white pattern.

(c) Definition of distribution of point defect is as follows:

-minimum separation between dark point defects should be larger than 5mm.

-minimum separation between bright point defects should be larger than 5mm. (d) Definition of

joined bright point defect and joined dark point defect are as follows:

-Two or more joined bright point defects must be nil.

-Three joined dark point defects must be nil.

-Coupling of one dark and one bright point in junction is counted as one dark and bright spot with 1 pair maximum.

-Two Joined dark point is counted as two dark points with 2 pair maximum.

Note2: The external inspection should be conducted at the distance 30 ± 5 cm between the eyes of inspector and the panel.

Note3: Luminance measurement for contrast ratio is at the distance 50 ± 5 cm between the detective head and the panel with ambient luminance less than 1 lux. Contrast ratio is obtained at optimum view angle.

Note4: W-Width in mm , L-length of Max.(L1,L2) in mm.

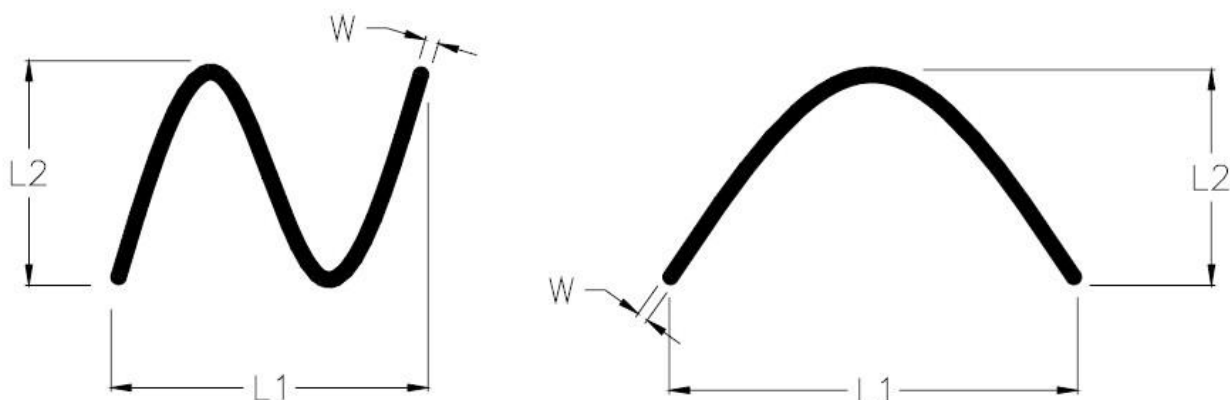

7.5 Sampling Condition

Unless otherwise agree in written, the sampling inspection shall be applied to the incoming inspection of customer.

Lot size: Quantity of shipment lot per model. Sampling

type: normal inspection, single sampling Sampling table:

MIL-STD-105E

Inspection level: Level II

7.6 Inspection conditions

The LCD shall be inspected under 40W white fluorescent light.

$\theta \leq 45^\circ$ inspection under non-operating condition.

$\theta \leq 5^\circ$ inspection under operating condition

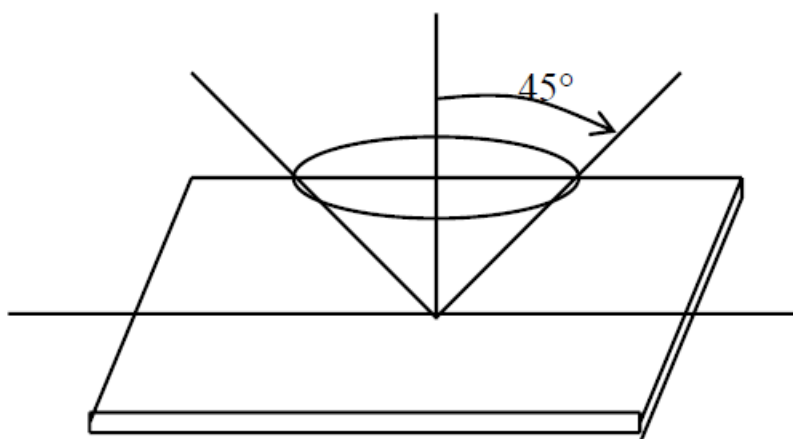

8. PRECAUTION RELATING PRODUCT HANDLING

8.1 SAFETY

- 8.1.1 If the LCD panel breaks, be careful not to get the liquid crystal to touch your skin.
- 8.1.2 If the liquid crystal touches your skin or clothes, please wash it off immediately by using soap and water.

8.2 HANDLING

- 8.2.1 Avoid any strong mechanical shock which can break the glass.
- 8.2.2 Avoid static electricity which can damage the CMOS LSI—When working with the module, be sure to ground your body and any electrical equipment you may be using.
- 8.2.3 Do not remove the panel or frame from the module.
- 8.2.4 The polarizing plate of the display is very fragile. So, please handle it very carefully, Do not touch, push or rub the exposed polarizing with anything harder than an HB pencil lead (glass, tweezers, etc.)
- 8.2.5 Do not wipe the polarizing plate with a dry cloth, as it may easily scratch the surface of plate.
- 8.2.6 Do not touch the display area with bare hands, this will stain the display area.
- 8.2.7 Do not use ketonics solvent & aromatic solvent. Use with a soft cloth soaked with a cleaning naphtha solvent.
- 8.2.8 To control temperature and time of soldering is $280 \pm 10^{\circ}\text{C}$ and 3-5 sec.
- 8.2.9 To avoid liquid (include organic solvent) stained on LCM.

8.3 STORAGE

- 8.3.1 Store the panel or module in a dark place where the temperature is $25^{\circ}\text{C} \pm 5^{\circ}\text{C}$ and the humidity is below 65% RH.
- 8.3.2 Do not place the module near organics solvents or corrosive gases.
Do not crush, shake, or jolt the module