



DM-TFT20-436
2.0" 240x320 TRANSFLECTIVE
RESISTIVE TOUCH PANEL –SPI ,MCU,
RGB

Contents

- 1 Revision History
- 2 Main Features
- 3 Pin Description
- 4 Mechanical Drawing
- 5 Electrical Characteristics
- 6 Optical Characteristics
- 7 AC Characteristics
 - 7.1 8080 Series MCU Parallel Interface Timing Characteristics:18/16/9/8-bit Bus
 - 7.2 Serial Interface (3-line SPI system) Timing Characteristics
 - 7.3 Serial interface (4-line SPI system) Timing Characteristics
 - 7.4 RGB Interface Timing Characteristics
 - 7.5 Reset Timing Characteristics
- 8 TP Feature
 - 8.1 Conditions of use and storage
 - 8.2 Electrical property
 - 8.3 Mechanical property
 - 8.4 Optical property
- 9 Reliability
- 10 Warranty and Conditions

1 Revision History

Date	Changes
2022-06-17	First release

2 Main Features

Item	Specification	Unit
Size	2.0	Inch
Resolution	240(RGB) x 320	pixel
Module Dimension	35.8 x 52.10 x 3.85	mm
Display area	30.6 x 40.8	mm
Pixel pitch	0.1275 x 0.1275	mm
TFT Controller IC	ST7789	-
Interface	3/4 serial 8/9/16/18 Bit MCU 3/4SPI+16/18bit RGB	-
Display Color	65K/262K	colors
View Direction	WIDE VIEWING	O'clock
Display mode	Transflective/Normally Black	-
Operating temperature	-20~+70	°C
Storage temperature	-30~+80	°C
Module bonding technology	Use Tape bonding between LCM and RTP	-
Weight	TBD	g

3 Pin Description

No.	Symbol	Description
1	GND	Ground
2	VCI	Supply voltage(3.3V)
3	IOVCC	Power Supply (1.65-3.3V)
4	IM2	MPU Parallel interface bus and serial interface select If use RGB Interface must select serial interface. Fix this pin at VCI and GND.
5	IM1	
6	IM0	
7	RESET	This signal low will reset the device and must be applied to properly initialize the chip.
8	CS	Chip select input pin ("Low" enable). fix this pin at VCI or GND when not in use.
9	DC(SPI-SCL)	-Display data/command selection pin in parallel interface. -This pin is used to be serial interface clock. DC=' 1' : display data or parameter. DC=' 0' : command data. -If not used, please fix this pin at GND.
10	WR(SPI-RS)	-Write enable in MCU parallel interface. - Display data/command selection pin in 4-line serial interface. - Second Data lane in 2 data lane serial interface. -If not used, please fix this pin at GND.
11	RD	Serves as a read signal and MCU read data at the rising edge. fix this pin at VCI or GND when not in use.
12	VSYNC	Frame synchronizing signal for RGB interface operation. fix this pin at GND when not in use.
13	HSYNC	Line synchronizing signal for RGB interface operation. fix this pin at GND when not in use.
14	ENABLE	Data enable signal for RGB interface operation. fix this pin at GND when not in use.

15	DOTCLK	Dot clock signal for RGB interface operation. Fix this pin at GND when not in use.
16	SDA	Serial input signal. The data is latched on the rising edge of the SCL signal. fix this pin at VCI or GND when not in use.
17-34	DB0-DB17	18-bit parallel bi-directional data bus for MCU system and RGB interface mode . Fix to GND level when not in use
35	SDO	SPI interface output pin. -The data is output on the falling edge of the SCL signal. -If not used, let this pin open.
36	LEDA	Anode pin of backlight
37	LEDK1	Cathode pin OF backlight
38	LEDK2	Cathode pin OF backlight
39	LEDK3	Cathode pin OF backlight
40	LEDK4	Cathode pin OF backlight
41	XR(NC)	Touch panel Right Glass Terminal
42	YU(NC)	Touch panel Top Film Terminal
43	XL(NC)	Touch panel LIFT Glass Terminal
44	YD(NC)	Touch panel Bottom Film Terminal
45	GND	Ground

4 Mechanical Drawing

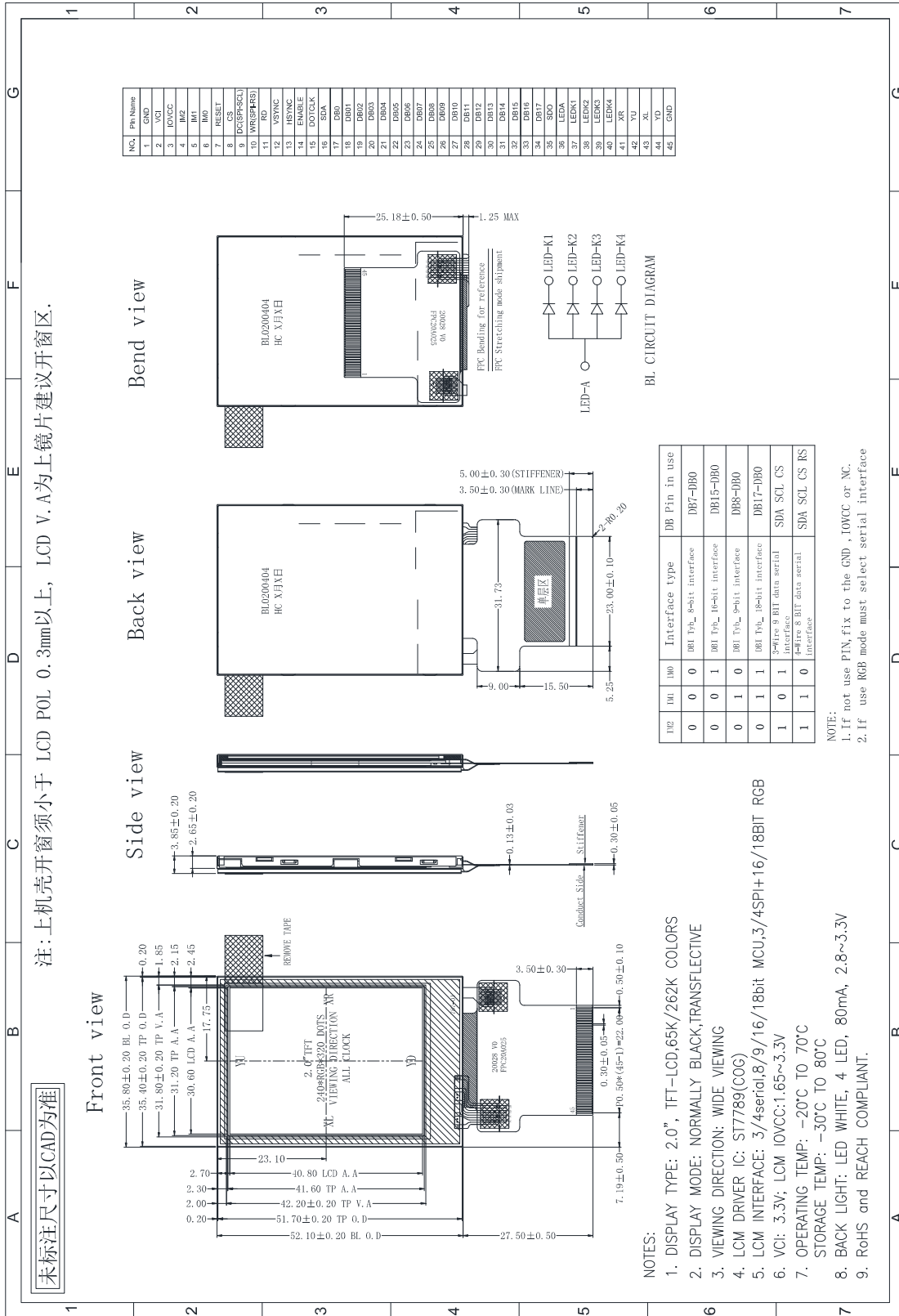

5 Electrical Characteristics

Item	Symbol	Condition	Min	Typ	Max	Unit
Digital Supply Voltage	VCI		2.5	3.3	3.6	V
Supply Voltage Logic	IOVCC		1.65	1.8	3.3	V
Normal mode Current	IDD		-	6.0	12	mA
Operating Temperature	TOP	Absolute Max	-20	-	+70	°C
Storage Temperature	TST	Absolute Max	-30	-	+80	°C
LED Forward Current	If		60	80	-	mA
LED Forward Voltage	Vf		2.8	3.2	3.3	V

6 Optical Characteristics

Item	Symbol	Min	Typ	Max	Unit
View Angles TOP	⊙ U	60	80	-	deg
View Angles Bottom	⊙ D	60	80	-	deg
View Angles Right	⊙ R	60	80	-	deg
View Angles Left	⊙ L	60	80	-	deg
Response Time	Tr +Tf		25	50	ms
Contrast Ratio	CR	200	250	-	--
LCM Luminance	Lv	150	200	-	cd/m ²

7 AC Characteristics

7.1 8080 Series MCU Parallel Interface Timing Characteristics:18/16/9/8-bit Bus

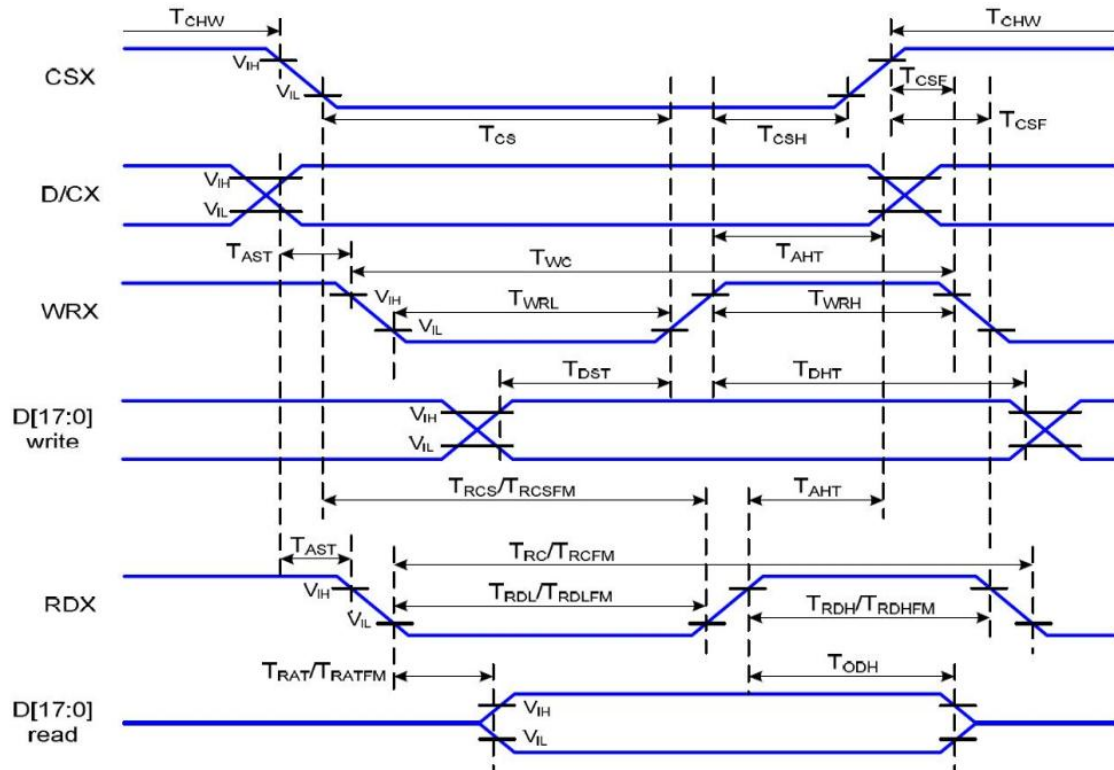

Figure6-1-1 Parallel Interface Timing Characteristics (8080-Series MCU Interface)

$V_{DD1}=1.65$ to $3.3V$, $V_{DD}=2.4$ to $3.3V$, $AGND=DGND=0V$, $T_a=-30$ to 70 °C

Signal	Symbol	Parameter	Min	Max	Unit	Description
D/CX	T_{AST}	Address setup time	0		ns	
	T_{AHT}	Address hold time (Write/Read)	10		ns	
CSX	T_{CHW}	Chip select "H" pulse width	0		ns	
	T_{CS}	Chip select setup time (Write)	15		ns	
	T_{RCS}	Chip select setup time (Read ID)	45		ns	
	T_{RCSFM}	Chip select setup time (Read FM)	355		ns	
	T_{CSF}	Chip select wait time (Write/Read)	10		ns	
	T_{CSH}	Chip select hold time	10		ns	
WRX	T_{WC}	Write cycle	66		ns	

	T_{WRH}	Control pulse "H" duration	15		ns	
	T_{WRL}	Control pulse "L" duration	15		ns	
RDX(ID)	T_{RC}	Read cycle (ID)	160		ns	When read ID data
	T_{RDH}	Control pulse "H" duration (ID)	90		ns	
	T_{RDL}	Control pulse "L" duration (ID)	45		ns	
RDX(FM)	T_{RCFM}	Read cycle (FM)	450		ns	When read from frame memory
	T_{RDHFM}	Control pulse "H" duration(FM)	90		ns	
	T_{RDLFM}	Control pulse "L" duration(FM)	355		ns	
DB[17:0]	T_{DST}	Data setup time	10		ns	For CL=30pF
	T_{DHT}	Data hold time	10		ns	
	T_{RAT}	Read access time (ID)		40	ns	
	T_{RATFM}	Read access time (FM)		340	ns	
	T_{ODH}	Output disable time	20	80	ns	

Table6-1-1 8080 Parallel Interface Characteristics

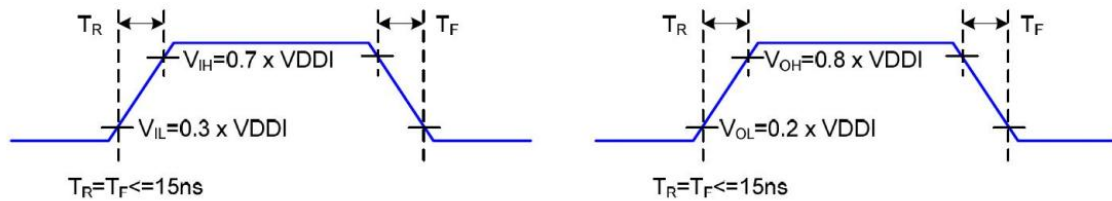

Figure6-1-2 Rising and Falling Timing for I/O Signal

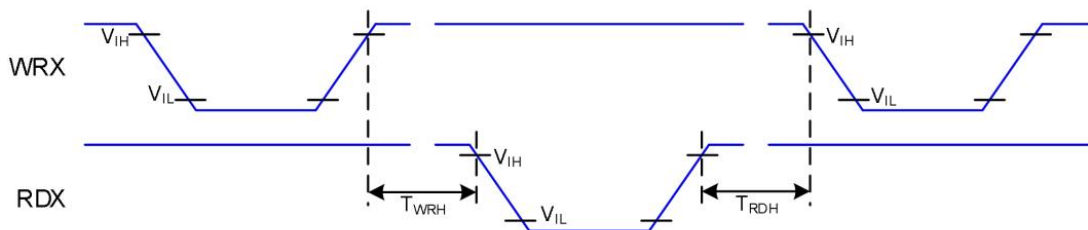
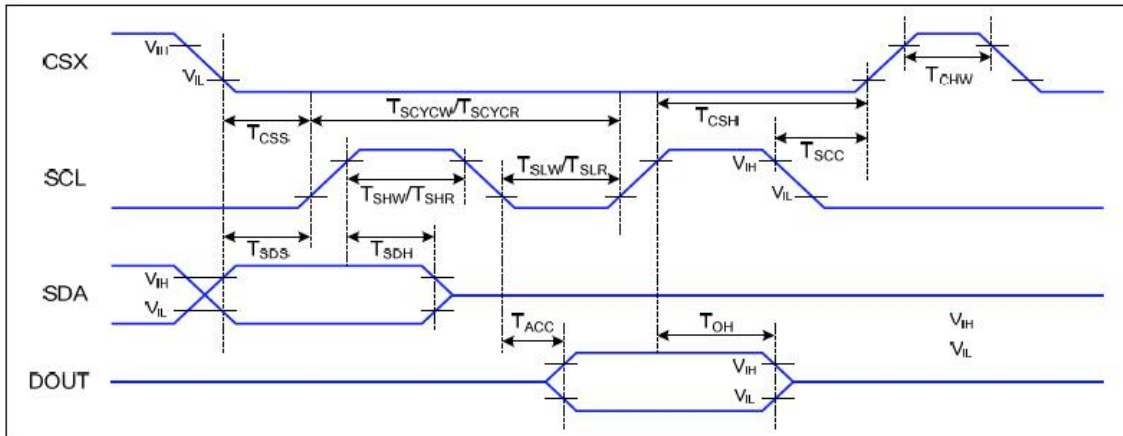

Figure6-1-3 Write-to-Read and Read-to-Write Timing

Note: The rising time and falling time (T_r , T_f) of input signal and fall time are specified at 15 ns or less. Logic high and low levels are specified as 30% and 70% of VDDI for Input signals.

7.2 Serial Interface (3-line SPI system) Timing Characteristics



VDDI=1.65 to 3.3V, VDD=2.4 to 3.3V, AGND=DGND=0V, T_a =-30 to 70 °C

Signal	Symbol	Parameter	Min	Max	Unit	Description
CSX	T_{CSS}	Chip select setup time (write)	15		ns	
	T_{CSH}	Chip select hold time (write)	15		ns	
	T_{CSS}	Chip select setup time (read)	60		ns	
	T_{SCC}	Chip select hold time (read)	65		ns	
	T_{CHW}	Chip select "H" pulse width	40		ns	
SCL	T_{SCYCW}	Serial clock cycle (Write)	66		ns	
	T_{SHW}	SCL "H" pulse width (Write)	15		ns	
	T_{SLW}	SCL "L" pulse width (Write)	15		ns	
	T_{SCYCR}	Serial clock cycle (Read)	150		ns	
	T_{SHR}	SCL "H" pulse width (Read)	60		ns	
	T_{SLR}	SCL "L" pulse width (Read)	60		ns	
SDA (DIN)	T_{SDS}	Data setup time	10		ns	
	T_{SDH}	Data hold time	10		ns	
DOUT	T_{ACC}	Access time	10	50	ns	For maximum CL=30pF
	T_{OH}	Output disable time	15	50	ns	For minimum CL=8pF

7.3 Serial interface (4-line SPI system) Timing Characteristics

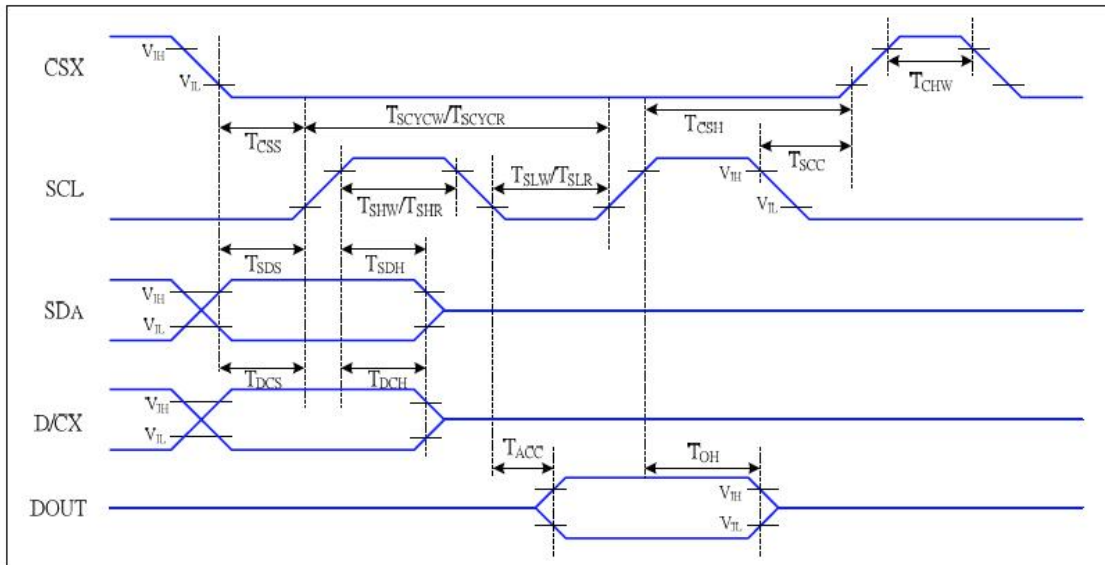

VDDI=1.65 to 3.3V, VDD=2.4 to 3.3V, AGND=DGND=0V, T_a =-30 to 70 °C

Signal	Symbol	Parameter	MIN	MAX	Unit	Description
CSX	T_{CSS}	Chip select setup time (write)	15		ns	
	T_{CSH}	Chip select hold time (write)	15		ns	
	T_{CSS}	Chip select setup time (read)	60		ns	
	T_{SCC}	Chip select hold time (read)	65		ns	
	T_{CHW}	Chip select "H" pulse width	40		ns	
SCL	T_{SCYCW}	Serial clock cycle (Write)	66		ns	-write command & data ram
	T_{SHW}	SCL "H" pulse width (Write)	15		ns	
	T_{SLW}	SCL "L" pulse width (Write)	15		ns	
	T_{SCYCR}	Serial clock cycle (Read)	150		ns	-read command & data ram
	T_{SHR}	SCL "H" pulse width (Read)	60		ns	
	T_{SLR}	SCL "L" pulse width (Read)	60		ns	
D/CX	T_{DCS}	D/CX setup time	10		ns	
	T_{DCH}	D/CX hold time	10		ns	
SDA (DIN)	T_{SDS}	Data setup time	10		ns	
	T_{SDH}	Data hold time	10		ns	
DOUT	T_{ACC}	Access time	10	50	ns	For maximum CL=30pF
	T_{OH}	Output disable time	15	50	ns	For minimum CL=8pF

Table6-2-1 4-line serial Interface Characteristics

Note: The rising time and falling time (T_r , T_f) of input signal are specified at 15 ns or less. Logic high and low levels are specified as 30% and 70% of VDDI for Input signals.

7.4 RGB Interface Timing Characteristics

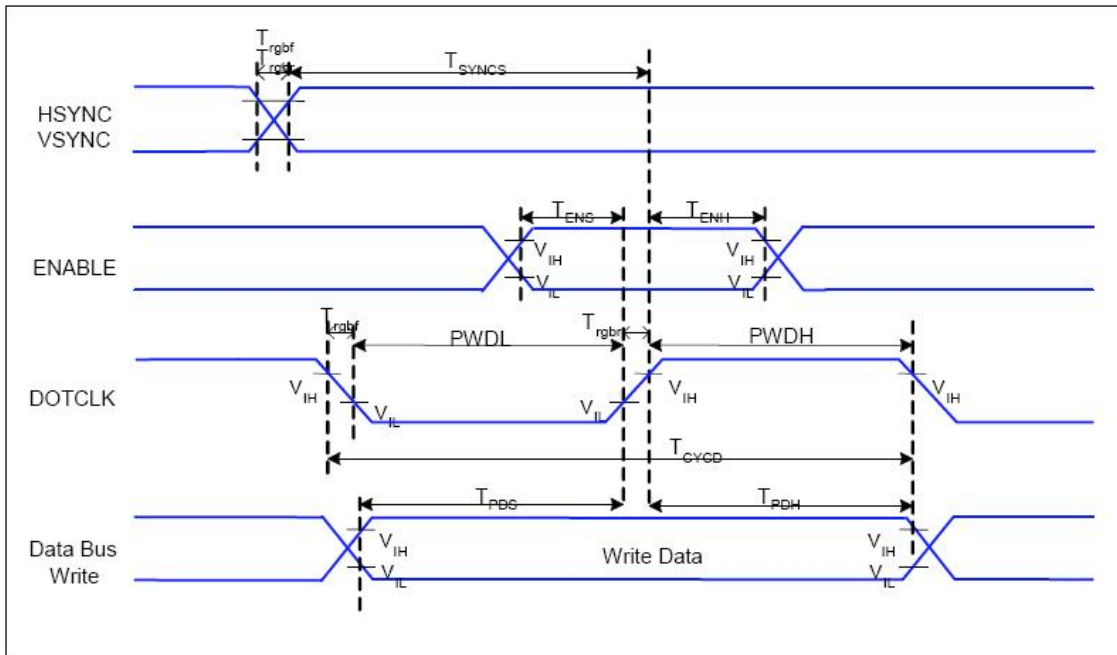

$V_{DD1}=1.65$ to $3.3V$, $V_{DD}=2.4$ to $3.3V$, $AGND=DGND=0V$, $T_a=-30 \sim 70 \text{ } ^\circ\text{C}$

Signal	Symbol	Parameter	MIN	MAX	Unit	Description
HSYNC, VSYNC	T_{SYNCS}	VSYNC, HSYNC Setup Time	30	-	ns	
ENABLE	T_{ENS}	Enable Setup Time	25	-	ns	
	T_{ENH}	Enable Hold Time	25	-	ns	
DOTCLK	$PWDH$	DOTCLK High-level Pulse Width	60	-	ns	
	$PWDL$	DOTCLK Low-level Pulse Width	60	-	ns	
	T_{CYCD}	DOTCLK Cycle Time	120	-	ns	
	T_{rghf}	DOTCLK Rise/Fall time	-	20	ns	
DB	T_{PDS}	PD Data Setup Time	50	-	ns	
	T_{PDH}	PD Data Hold Time	50	-	ns	

7.5 Reset Timing Characteristics

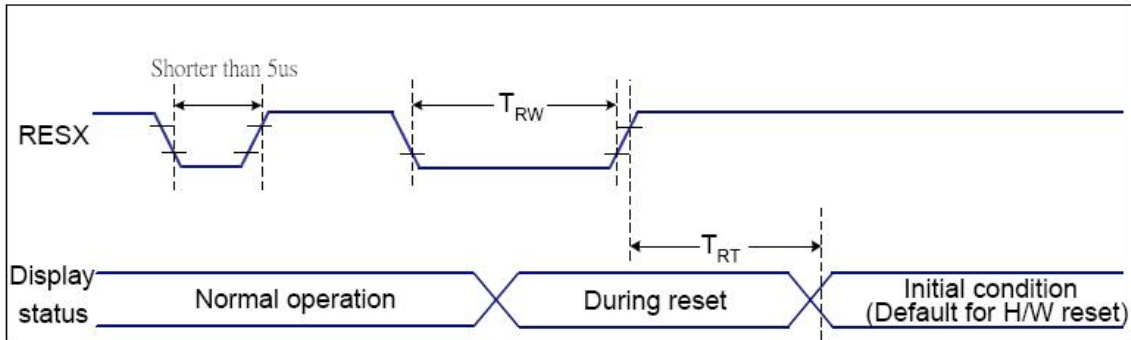

$V_{DD1}=1.65$ to $3.3V$, $V_{DD}=2.4$ to $3.3V$, $AGND=DGND=0V$, $T_a=-30 \sim 70$ °C

Related Pins	Symbol	Parameter	MIN	MAX	Unit
RESX	TRW	Reset pulse duration	10	-	us
	TRT	Reset cancel	-	5 (Note 1, 5)	ms
			120 (Note 1, 6, 7)	ms	

Notes:

1. The reset cancel includes also required time for loading ID bytes, VCOM setting and other settings from NVM (or similar device) to registers. This loading is done every time when there is HW reset cancel time (TRT) within 5 ms after a rising edge of RESX.
2. Spike due to an electrostatic discharge on RESX line does not cause irregular system reset according to the table below:

RESX Pulse	Action
Shorter than 5us	Reset Rejected
Longer than 9us	Reset
Between 5us and 9us	Reset starts

3. During the Resetting period, the display will be blanked (The display is entering blanking sequence, which maximum time is 120 ms, when Reset Starts in Sleep Out –mode. The display remains the blank state in Sleep In –mode.) and then return to Default condition for Hardware Reset.

4. Spike Rejection also applies during a valid reset pulse as shown below:

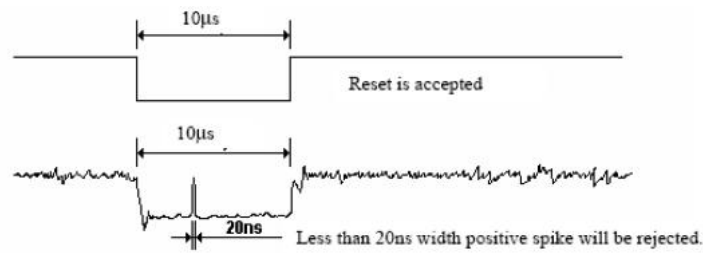

5. When Reset applied during Sleep In Mode.

6. When Reset applied during Sleep Out Mode.

7. It is necessary to wait 5msec after releasing RESX before sending commands. Also Sleep Out command cannot be sent for 120msec.

8 TP Feature

8.1 Conditions of use and storage

Item	Value(condition)	Note
Temperature range upon operation	Humidity: 20%~90% non dew, condensation -30℃~85℃	In a simple substance
Temperature range upon storage	Humidity: 20%~90% non dew, condensation -40℃~90℃	In a simple substance

8.2 Electrical property

Item	Value	Note
Maximum voltage	DC5V	
Resistance between terminals	X direction[Film side]:200-600Ω Y direction [Glass side]:300-900Ω	
Insulation resistance	DC 25V 20MΩor above	Connect X + ~X- and Y+ ~Y-, apply 25VDC Between X and Y for perform measurements
Chattering	10 msec or below	
Rating	Voltage is DC 5V	

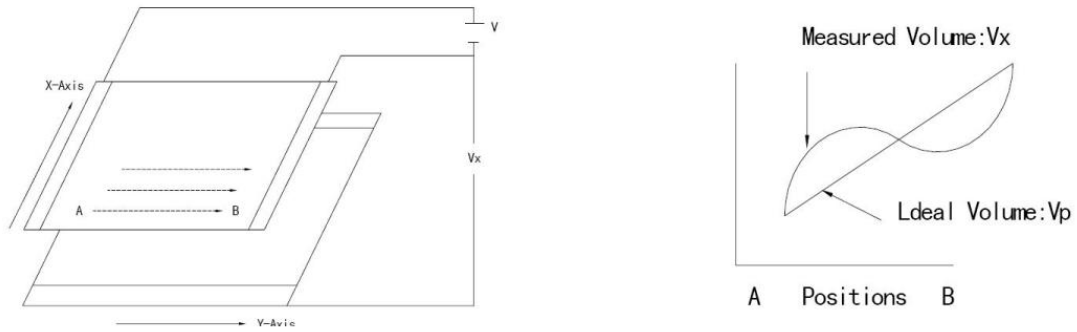

8.3 Mechanical property

Item	Performance	Note
Input method	Used of an exclusive pen or finger	
Load upon operation	Exclusive pen	60-100g or below Operation and measurement with a pen must be carried out under the following tip conditions: Stylus pen material : POM(polyacetal) . Tip : Diameter 3.0mm, SR 0.8 mm
	Finger	60-100g or below Operations and measurement methods simulated for a finger must be carried out under the following tip conditions. Material :Silicon rubber (Hardness : 30°Hs) Tip : Diameter 12.0 mm, SR 12.5mm
Surface hardness	Pencil hardness : 3H or above	It complies with the way of test method JIS K5400.

8.4 Optical property

Item	Performance	Note
Total light transmittance	80% or above	JIS K7105
Haze	5% or below	JIS K7136
Film specification	Matte type with hard coated surface	

9 Reliability

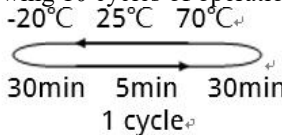
Test Item	Content of Test	Test Condition	Note
High Temperature Storage	Endurance test applying the high storage temperature for a long time.	80°C 200hrs	2
Low Temperature Storage	Endurance test applying the high storage temperature for a long time.	-30°C 200hrs	1,2
High Temperature Operation	Endurance test applying the electric stress (Voltage & Current) and the thermal stress to the element for a long time.	70°C 200hrs	-
Low Temperature Operation	Endurance test applying the electric stress under low temperature for a long time.	-20°C 200hrs	1
High Temperature/ Humidity Operation	The module should be allowed to stand at 60°C,90%RH max, for 96hrs under no-load condition excluding the polarizer. Then taking it out and drying it at normal temperature.	60°C,90%RH 96hrs	1,2
Thermal Shock Resistance	The sample should be allowed stand the following 10 cycles of operation. 	-20°C/70°C 10 cycles	-
Vibration Test	Endurance test applying the vibration during transportation and using.	Total fixed amplitude: 15mm; Vibration: 10~55Hz; One cycle 60 seconds to 3 directions of X, Y, Z, for each 16 minutes.	3
Static Electricity Test	Endurance test apply the electric stress to the terminal.	VS=800V, RS=1.5kΩ, CS=100pF, 1 time.	-

Note1: No dew condensation to be observed.

Note2: The function test shall be conducted after 4 hours storage at the normal. Temperature and humidity after remove from the rest chamber.

Note3: Test performed on product itself, not inside a container

10 Warranty and Conditions

<http://www.displaymodule.com/pages/faq>