



DM-TFT18-308

**1.8" TFT DISPLAY WITH 8-BIT MCU
INTERFACE, HOT-BAR SOLDERING
CONNECTION**

Contents

1	Revision History	3
2	Main Features	3
3	Pin Description.....	4
4	Mechanical Drawing	5
5	Electrical Characteristics.....	6
6	Optical Characteristics.....	6
7	Timing Characteristics	7
7.1	Display Parallel 8-bit Interface Timing Characteristics (8080-system).....	7
7.2	Reset Timing Characteristics	8
8	Reliability.....	10
9	Warranty and Conditions	11

1 Revision History

Date	Changes
2015-01-21	First release

2 Main Features

Item	Specification	Unit
Screen Size	1.77	inch
Driver Mode	Transmissive	-
Display Colors	65K	colors
Resolution	128 x 160	dots
Controller IC	Ilitek ILI9163	-
Interface	8bit MCU	-
Power Supply	3.3	V
View Direction	12 o'clock	-
Background LED	2 LED Normally White	-
Weight	7.5	g

3 Pin Description

Pin No.	Symbol	Function Description
1	RESET	Active LOW Reset signal
2	CS	Chip select input pin (LOW enable)
3	RS/A0	Display data / Common selection D/CX='1': Display data D/CX='0': Command data
4	WR	Write enable in parallel interface
5	DB0	Data bus
6	DB1	Data bus
7	DB2	Data bus
8	DB3	Data bus
9	DB4	Data bus
10	DB5	Data bus
11	DB6	Data bus
12	DB7	Data bus
13	DB8	Connect to GND
14	DB9	Connect to GND
15	DB10	Connect to GND
16	DB11	Connect to GND
17	DB12	Connect to GND
18	DB13	Connect to GND
19	DB14	Connect to GND
20	DB15	Connect to GND
21	VDD	Supply voltage (3.3V)
22	GND	Ground
23	LEDK1	Cathode pin of backlight (3.2V)
24	LEDA	Anode pin of backlight
25	LEDK2	Cathode pin of backlight (3.2V)
26	NC	No connection

5 Electrical Characteristics

Item	Symbol	Condition	Min	Typ.	Max	Unit
Supply Voltage For Logic	VDD		2.5	3.3	4.2	V
Digital Operation Current	IDD	VDD=3.3V	-	1.5	-	mA
Low Level Input Voltage	V _{IL}		GND	-	0.3VDD	V
High Level Input Voltage	V _{IH}		0.7VDD	-	VDD	V
Low Level Output Voltage	V _{OL}		GND		0.2VDD	V
High Level Output Voltage	V _{OH}		0.8VDD		VDD	V
Backlight Forward Voltage	V _{LED}		-	3.2	-	V
Backlight Forward Current	I _{LED}	V _{LED} =3.2V	30	40	-	mA
Operating Temperature	TOP	Absolute Max	-20	-	+70	°C
Storage Temperature	TST	Absolute Max	-30	-	+80	°C

6 Optical Characteristics

Item	Symbol	Min	Typ	Max	Unit	Note
View Angles Top		35	45		°	
View Angles Bottom		10	20		°	
View Angles Left		35	45		°	
View Angles Right		35	45		°	
Response Time (25°C)	Tr + Tf		8	16	ms	
Uniformity		80			%	
Contrast Ratio	CR	400	500			
Luminance	L _v	180	240		cd/m ²	

7 Timing Characteristics

7.1 Display Parallel 8-bit Interface Timing Characteristics (8080-system)

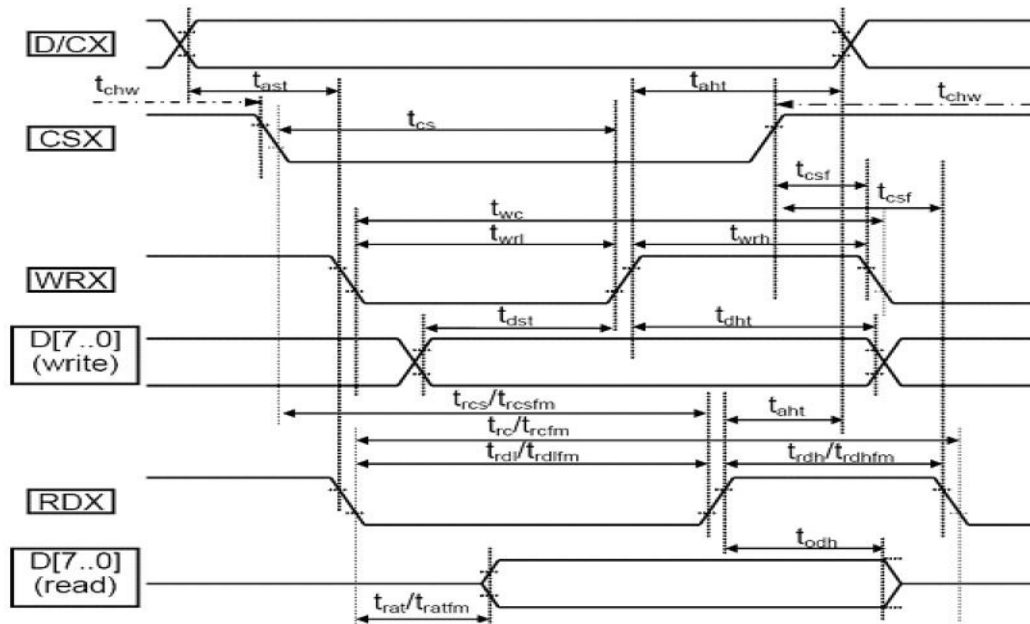

Note: Logic high and low levels are specified as 30% and 70% of VDDI for Input signals.

Signal	Symbol	Parameter	min	max	Unit	Note
D/CX	t _{ast}	Address setup time	0		ns	
	t _{ahw}	Address hold time(Write/Read)	10		ns	
CSX	t _{chw}	CSH "H" Pulse Width	0		ns	
	t _{csc}	Chip select setup time(Write)	10		ns	
	t _{rscs}	Chip select setup time(Read ID)	45		ns	
	t _{rscsfm}	Chip select setup time(Read FM)	355		ns	
	t _{cscf}	Chip select wait time(Write/Read)	10		ns	
WRX	t _{wc}	Write cycle	66		ns	
	t _{wrh}	Control pulse H duration	15.		ns	
	t _{wrl}	Control pulse L duration	15		ns	
RDX	t _{rc}	Read cycle (ID)	160		ns	When read ID data
	t _{rdh}	Control pulse H duration(ID)	90		ns	
	t _{rdl}	Control pulse L duration(ID)	45		ns	
RDX	t _{rscfm}	Read cycle (FM)	450		ns	When read from frame memory
	t _{rdhfm}	Control pulse H duration(FM)	90		ns	
	t _{rdlfm}	Control pules L duration(FM)	355		ns	
D[17 ...0]	t _{dst}	Data setup time	10		ns	For maximum CL=30pF for minimum CL=8pF
	t _{dht}	Data hold time	10		ns	
	t _{rat}	Read access time(ID)		40	ns	
	t _{ratfm}	Read access time(FM)		340	ns	
	t _{odh}	Output disable time	20	80	ns	

Note 1: VDDI 1.65 to 3.3V, VCI=2.6 to 3.3V, AGND=GND=0V, Ta=-30 to 70°C (to +85°C no change).

Note 2: This input signal rise time and fall time (t_r , t_f) is specified at 15 ns or less. Logic high and low levels are specified as 30% and 70% of VDDI for input signals.

7.2 Reset Timing Characteristics

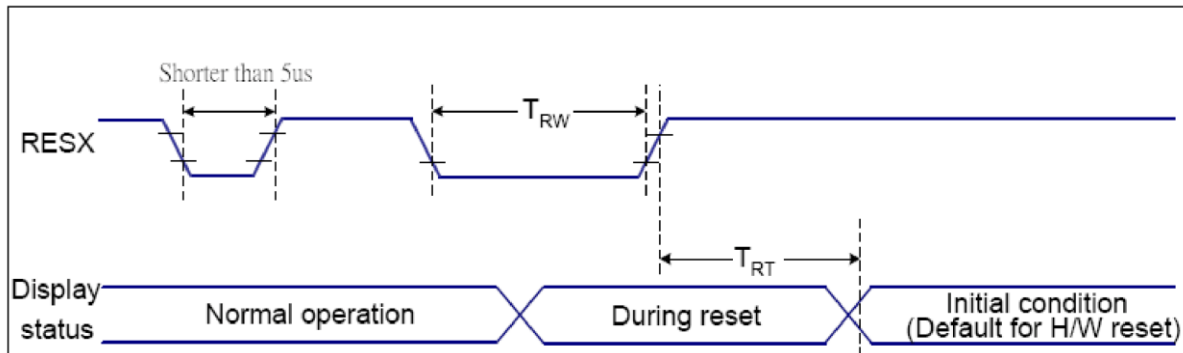

VDDI=1.65 to 3.3V, VDD=2.4 to 3.3V, AGND=DGND=0V, Ta=-30 ~ 70 °C

Related Pins	Symbol	Parameter	MIN	MAX	Unit
RESX	TRW	Reset pulse duration	10	-	us
	TRT	Reset cancel	-	5 (Note 1, 5)	ms
				120 (Note 1, 6, 7)	ms

Notes:

1. The reset cancel includes also required time for loading ID bytes, VCOM setting and other settings from NVM (or similar device) to registers. This loading is done every time when there is HW reset cancel time (t_{RT}) within 5 ms after a rising edge of RESX.

2. Spike due to an electrostatic discharge on RESX line does not cause irregular system reset according to the table below:

RESX Pulse	Action
Shorter than 5us	Reset Rejected
Longer than 9us	Reset
Between 5us and 9us	Reset starts

3. During the Resetting period, the display will be blanked (The display is entering blanking sequence, which maximum time is 120 ms, when Reset Starts in Sleep Out -mode. The display remains the blank state in Sleep In -mode.) and then return to Default condition for Hardware Reset.

4. Spike Rejection also applies during a valid reset pulse as shown below:

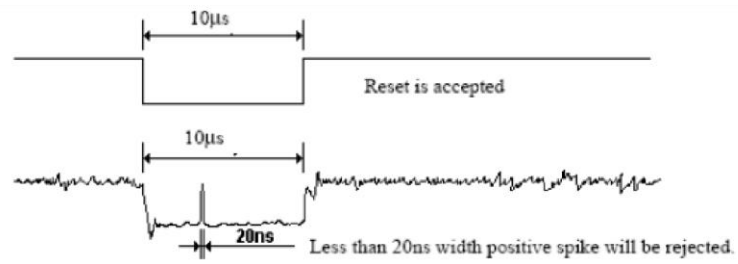

5. When Reset applied during Sleep In Mode.
6. When Reset applied during Sleep Out Mode.
7. It is necessary to wait 5msec after releasing RESX before sending commands. Also Sleep Out command cannot be sent for 120msec.

8 Reliability

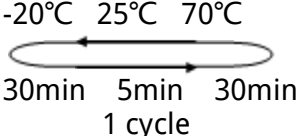
Test Item	Content of Test	Test Condition	Note
High Temperature Storage	Endurance test applying the high storage temperature for a long time.	80°C 200hrs	2
Low Temperature Storage	Endurance test applying the high storage temperature for a long time.	-30°C 200hrs	1,2
High Temperature Operation	Endurance test applying the electric stress (Voltage & Current) and the thermal stress to the element for a long time.	70°C 200hrs	-
Low Temperature Operation	Endurance test applying the electric stress under low temperature for a long time.	-20 °C 200hrs	1
High Temperature/ Humidity Operation	The module should be allowed to stand at 60°C,90%RH max, For 96hrs under no-load condition excluding the polarizer, Then taking it out and drying it at normal temperature.	60°C,90%RH 96hrs	1,2
Thermal Shock Resistance	The sample should be allowed stand the following 10 cycles of operation 	-20°C/70°C 10 cycles	-
Vibration Test	Endurance test applying the vibration during transportation and using	Total fixed amplitude: 15mm; Vibration: 10~55Hz; One cycle 60 seconds to 3 directions of X, Y, Z, for each 16 minutes.	3
Static Electricity Test	Endurance test apply the electric stress to the terminal.	VS=800V, RS=1.5kΩ, CS=100pF, 1 time.	-

Note1: No dew condensation to be observed.

Note2: The function test shall be conducted after 4 hours storage at the normal. Temperature and humidity after remove from the rest chamber.

Note3: The packing have to including into the vibration testing.

9 Warranty and Conditions

<http://www.displaymodule.com/pages/faq>