



DM-OLED32-618
WHITE GRAPHIC OLED DISPLAY WITH
8-BIT 6800/8080 PARALLEL OR
3/4-WIRE SPI MPU INTERFACE

Contents

[Revision History](#)

[Main Features](#)

[Pin Description](#)

[Mechanical Drawing](#)

[Electrical Characteristics](#)

[Optical Characteristics](#)

[MCU Interface](#)

[MCU Parallel 6800-series Interface](#)

[MCU Parallel 8080-series Interface](#)

[MCU Serial Interface \(4-wire SPI\)](#)

[MCU Serial Interface \(3-wire SPI\)](#)

[Driver/Controller Information](#)

[Application Reference](#)

[Example Initialization Code](#)

[Reliability](#)

[Warranty and Conditions](#)

1 Revision History

Date	Changes
2015-03-13	First release
2016-10-18	Initialization Code Fix

2 Main Features

Item	Specification	Unit
Diagonal Size	3.2	inch
Display Mode	OLED	-
Display Colors	White	
Resolution	256 x 64	
Controller IC	SSD1322	-
Duty	1/64	
Interface	8-Bit 6800/8080 Parallel、3/4-Wire Serial SPI	-
Power Supply	3.3/5V	V
Viewing Area	78.78 x 21.18	mm
Weight	24.7	g

3 Pin Description

Pin No.	Symbol	Function Description
1	VSS	Ground of Logic Circuit This is a ground pin. It also acts as a reference for the logic pins. It must be connected to external ground.
2	VBAT	Power Supply for Display Module Circuit This is a voltage supply pin. It connected to external source.
3	NC	Please let it Float.
4-11	DB0-DB7	Host Data Input/output Bus These pins are 8-bits bi-directional data bus to be connected to the microprocessor's data bus. When serial mode is selected, D1 will be the serial data input SDIN and D0 will be the serial clock input SCLK.
12	/RD	Read/Write Enable or Read This pin is MCU interface input. When interfacing to a 68XX-series microprocessor, this pin while used as the Enable (E) signal. Read/Write operation is initiated when this pin is pulled high and the CS is pulled low. When connecting to an 80xx-microprocessor, this pin receives the Read (RD) signal. Data read operation is initiated when this pin is pulled low CS is pulled low.
13	/WR	Read/Write Select or Write This pin is MCU interface input. When interfacing to a 68xx-series microprocessor, this pin will be used as Read/Write (R/W) selection input. Pull this pin to "High" for read mode and pull it to "Low" for write mode. When 80xx interface mode is selected, this pin will be the write (WR) input. Data write operation is initiated when this pin is pulled low and the CS is pulled low.
14	/DC	Data/Command Control This pin is Data/Command control pin. When the pin is pulled high, the input at D7~D0 is treated as display data. When the pin is pulled low, the input at D7~D0 will be transferred to the command register. For detail relationship to MCU interface signals, please refer to the Timing Characteristics Diagrams.
15	/Reset	Power Reset for Controller and Driver This pin is reset signal input. When the pin is low, initialization of the chip is executed.
16	/CS	Chip Select This pin is the chip select input. The chip is enable for MCU communication only when CS# is pulled low.

4 Mechanical Drawing

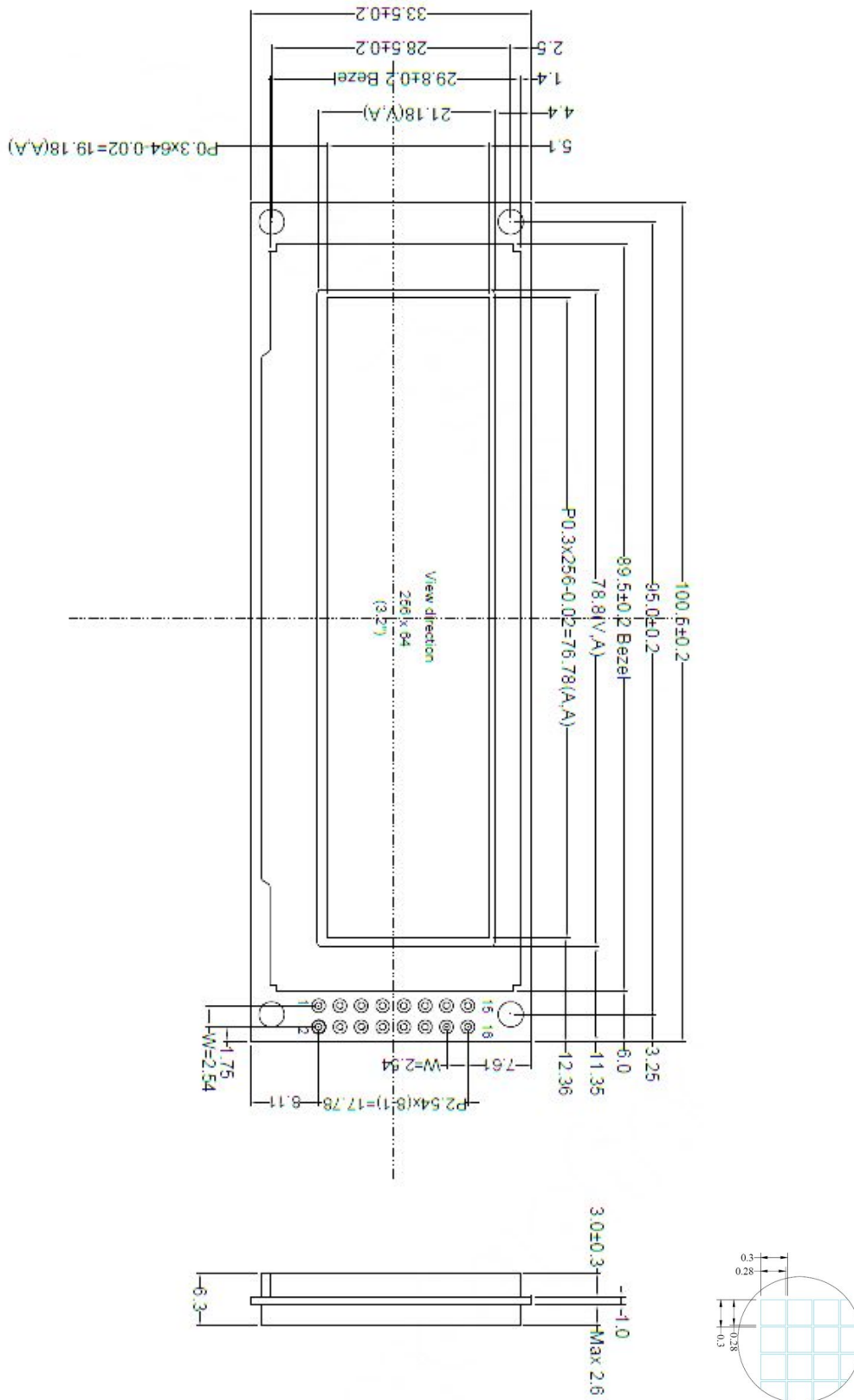

5 Electrical Characteristics

Item	Symbol	Condition	Min	Typ.	Max	Unit
Supply Voltage for Logic	V _{BAT}		3.3		5.0	V
Digital Operation Current	I _{V_{BAT}}	-		250	-	mA
Display Voltage	V _{CC}		11.5	12.0	12.5	V
Low Level Input Voltage	V _{IL}		0	-	0.2xVDD	V
High Level Input Voltage	V _{IH}		0.8xVDD	-	VDD	V
Low Level Output Voltage	V _{OL}		0		0.1xVDD	V
High Level Output Voltage	V _{OH}		0.9xVDD		VDD	V
Operating Temperature	TOP	Absolute Max	-30		85	°C
Storage Temperature	TST	Absolute Max	-40		90	°C

6 Optical Characteristics

Item	Symbol	Min	Typ	Max	Unit
View Angles Left	AH		80		°
View Angles Right	AH		80		°
View Angles Top	AV		80		°
View Angles Bottom	AV		80		°
Response Time (25°C)	Tr + Tf		20		us
View Angle		> 160			degree
Brightness	L _v	60	90		cd/m ²
Lifetime		10,000			Hrs

7 MCU Interface

MCU interface assignment under different bus interface mode

Bus Interface	Data/Command Interface								Control Signal				
	D7	D6	D5	D4	D3	D2	D1	D0	E	R/W#	CS#	D/C#	RES#
8-bit 8080	D[7:0]								RD#	WR#	CS#	D/C#	RES#
8-bit 6800	D[7:0]								E	R/W#	CS#	D/C#	RES#
3-wire SPI	Tie LOW			NC		SDIN	SCLK	Tie LOW		CS#	Tie LOW	RES#	
4-wire SPI	Tie LOW			NC		SDIN	SCLK	Tie LOW		CS#	D/C#	RES#	

7.1 MCU Parallel 6800-series Interface

The parallel interface consists of 8 bi-directional data pins (D[7:0]), R/W#, D/C#, E and CS#.

A LOW in R/W# indicates WRITE operation and HIGH in R/W# indicates READ operation.

A LOW in D/C# indicates COMMAND read/write and HIGH in D/C# indicates DATA read/write.

The E input serves as data latch signal while CS# is LOW. Data is latched at the falling edge of E signal.

Function	E	R/W#	CS#	D/C#
Write command	↓	L	L	L
Read status	↓	H	L	L
Write data	↓	L	L	H
Read data	↓	H	L	H

Note: ↓ stands for falling edge of signal

H stands for HIGH in signal

L stands for LOW in signal

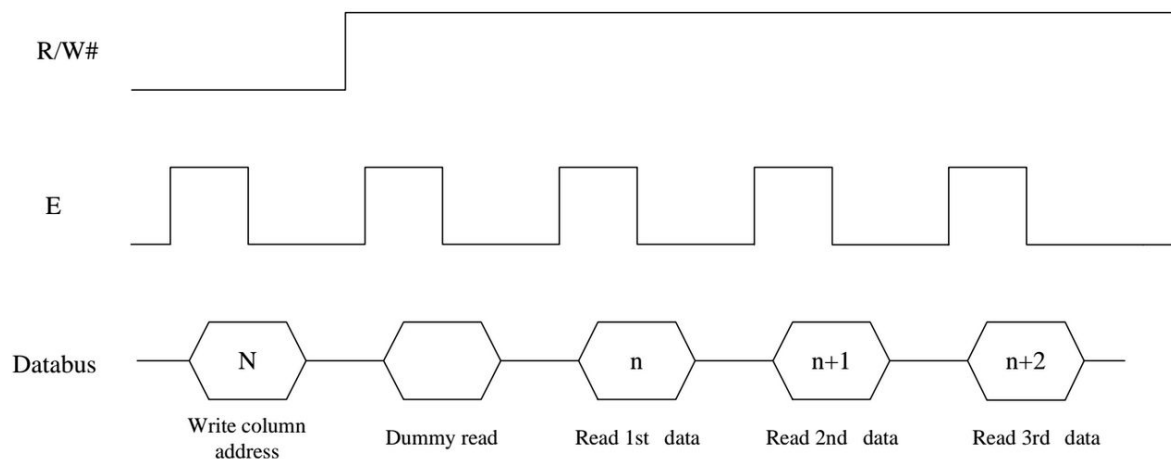

Data read back procedure - insertion of dummy read

7.2 MCU Parallel 8080-series Interface

The parallel interface consists of 8 bi-directional data pins (D[7:0]), RD#, WR#, D/C# and CS#.

A LOW in D/C# indicates COMMAND read/write and HIGH in D/C# indicates DATA read/write.

A rising edge of RD# input serves as a data READ latch signal while CS# is kept LOW.

A rising edge of WR# input serves as a data/command WRITE latch signal while CS# is kept LOW.

Function	RD#	WR#	CS#	D/C#
Write command	H	↑	L	L
Read status	↑	H	L	L
Write data	H	↑	L	H
Read data	↑	H	L	H

Note: ↑ stands for rising edge of signal

H stands for HIGH in signal

L stands for LOW in signal

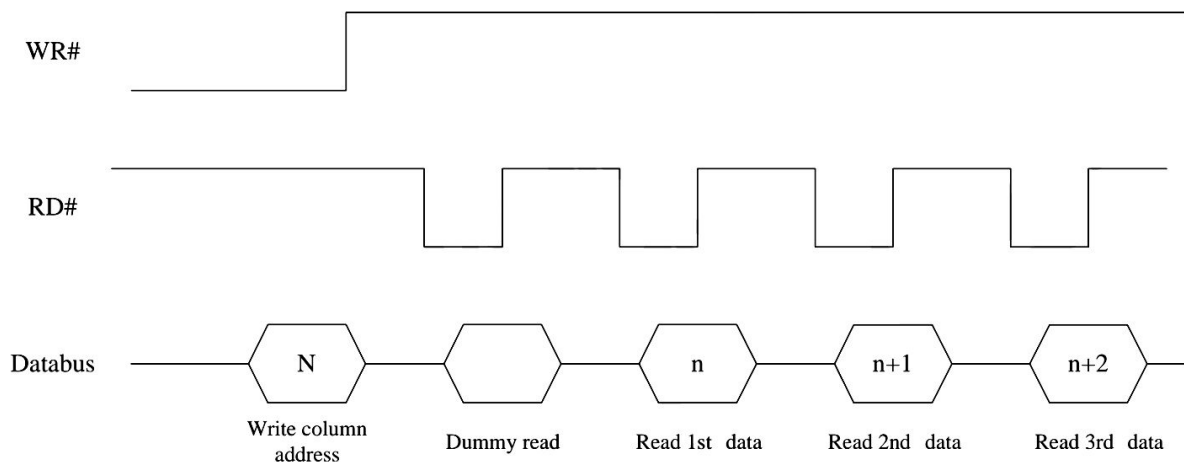

Display data read back procedure - insertion of dummy read

7.3 MCU Serial Interface (4-wire SPI)

The serial interface consists of serial clock SCLK, serial data SDIN, D/C#, CS#. In SPI mode, D0 acts as SCLK, D1 acts as SDIN. For the unused data pins, D2 should be left open. The pins from D3 to D7, E and R/W# can be connected to an external ground.

Function	E(RD#)	R/W#(WR#)	CS#	DC#	D0#
Write command	Tie LOW	Tie LOW	L	L	↑
Write data	Tie LOW	Tie LOW	L	H	↑

Note: H stands for HIGH in signal
L stands for LOW in signal

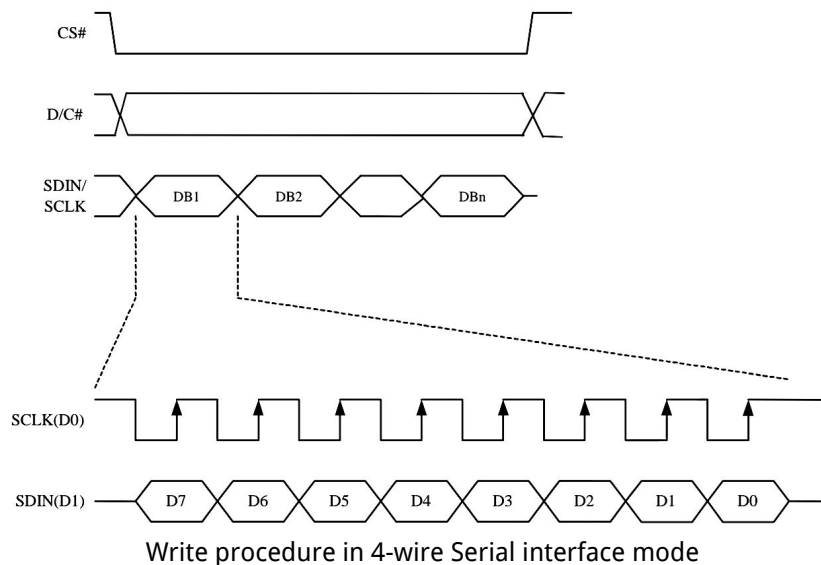

7.4 MCU Serial Interface (3-wire SPI)

The 3-wire serial interface consists of serial clock SCLK, serial data SDIN and CS#. In 3-wire SPI mode, D0 acts as SCLK, D1 acts as SDIN. For the unused data pins, D2 should be left open. The pins from D3 to D7, R/W# (WR#), E(RD#) and D/C# can be connected to an external ground.

Function	E(RD#)	R/W#(WR#)	CS#	D/C#	D0
Write command	Tie LOW	Tie LOW	L	Tie LOW	↑
Write data	Tie LOW	Tie LOW	L	Tie LOW	↑

Note: L stands for LOW in signal

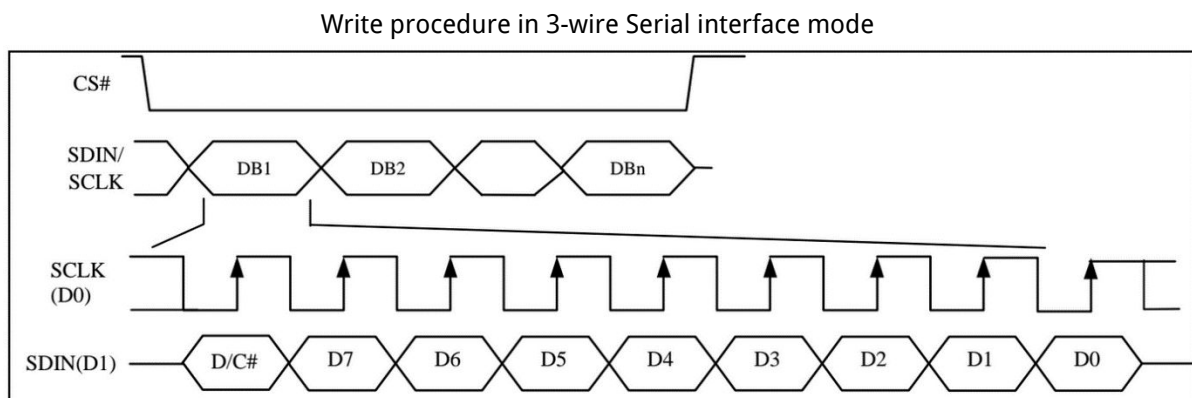

8 Driver/Controller Information

Built-in SSD1322 Controller:

<https://drive.google.com/file/d/0Bxu0OURUiyL5dHVRbVj1MEZBcWc/view?usp=sharing>

9 Application Reference

The Parallel (8080 Series MCU) Reference Example

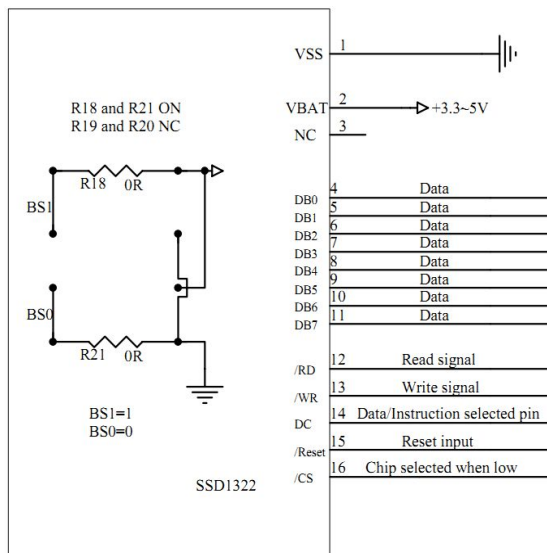

The Parallel (6800 Series MCU) Reference Example

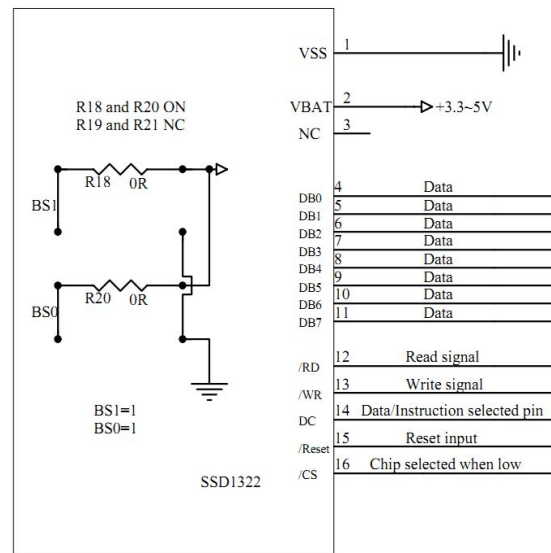

The Serial 4 Line SPI Reference Example

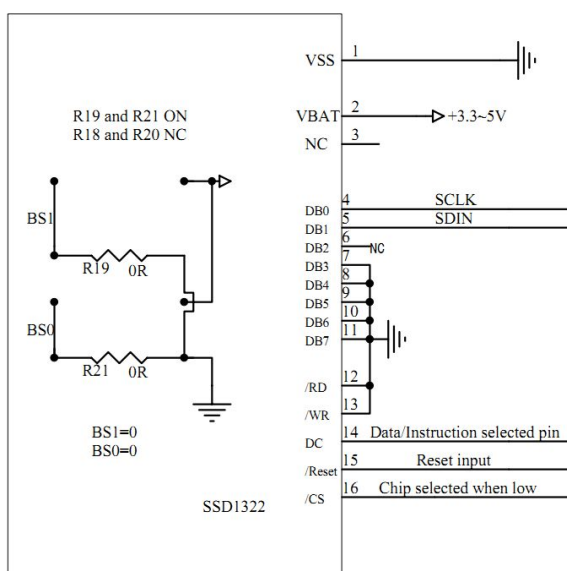

The Serial 3 Line SPI Reference Example

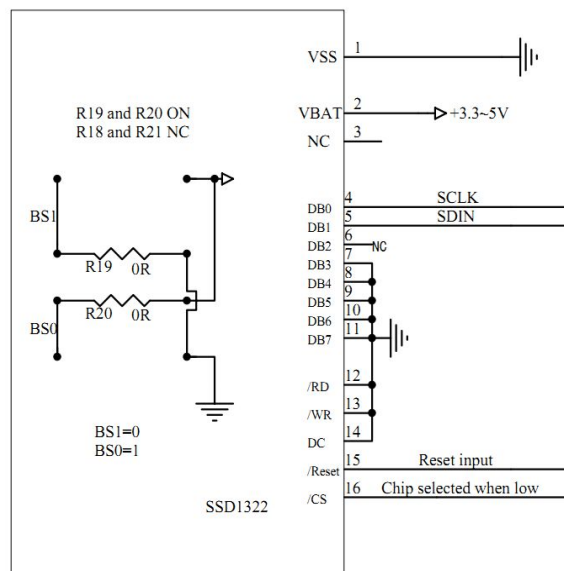

10 Example Initialization Code

```
void Write_Data(unsigned char dat)
{
    RS=1;
    CS=0;
    _RW=0;
    DATA_BUS=dat;
    Delays(2);
    _RW=1;
    CS=1;
}

-----
void Write_Instruction(unsigned char cmd)
{
    RS=0;
    CS=0;
    _RW=0;
    DATA_BUS=cmd;
    Delays(2);
    _RW=1;
    CS=1;
}

-----
void LCD_initialize(void)
{
    RES=1; Delays(200);
    RES=0; Delays(200);
    RES=1; Delays(200);
    Write_Instruction(0xFD); /*SET COMMAND LOCK */
    Write_Data(0x12); /* UNLOCK */
    Write_Instruction(0xAE); /*DISPLAY OFF*/
    Write_Instruction(0xB3); /*DISPLAYDIVIDE CLOCKRADIO/OSCILLATAR FREQUANCY*/
    Write_Data(0x91);
    Write_Instruction(0xCA); /*multiplex ratio*/
    Write_Data(0x3F); /*duty = 1/64*/
    Write_Instruction(0xA2); /*set offset*/
    Write_Data(0x00);
    Write_Instruction(0xA1); /*start line*/
    Write_Data(0x00);
    Write_Instruction(0xA0); /*set remap*/
    Write_Data(0x14); Write_Data(0x11);
    Write_Instruction(0xAB); /*funtion selection*/
    Write_Data(0x01); /* selection external vdd */
    Write_Instruction(0xB4);
    Write_Data(0xA0); Write_Data(0xFD);
    Write_Instruction(0xC1); /*set contrast current */
    Write_Data(Contrast_level);
    Write_Instruction(0xC7); /*master contrast current control*/
    Write_Data(0x0F);
    Write_Instruction(0xB1); /*SET PHASE LENGTH*/
    Write_Data(0xE2);
    Write_Instruction(0xD1);
    Write_Data(0x82); Write_Data(0x20);
    Write_Instruction(0xBB); /*SET PRE-CHANGE VOLTAGE*/
    Write_Data(0x1F);
    Write_Instruction(0xB6); /*SET SECOND PRE-CHARGE PERIOD*/
    Write_Data(0x08);
    Write_Instruction(0xBE); /* SET VCOMH */
    Write_Data(0x07);
    Write_Instruction(0xA6); /*normal display*/
    Clear_ram();
    Write_Instruction(0xAF); /*display ON*/
}
```

11 Reliability

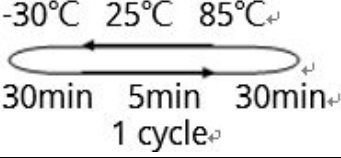
Test Item	Content of Test	Test Condition	Note
High Temperature Storage	Endurance test applying the high storage temperature for a long time.	80°C 200hrs	2
Low Temperature Storage	Endurance test applying the high storage temperature for a long time.	-30°C 200hrs	1,2
High Temperature Operation	Endurance test applying the electric stress (Voltage & Current) and the thermal stress to the element for a long time.	70°C 200hrs	-
Low Temperature Operation	Endurance test applying the electric stress under low temperature for a long time.	-20 °C 200hrs	1
High Temperature/ Humidity Operation	The module should be allowed to stand at 60°C,90%RH max, for 96hrs under no-load condition excluding the polarizer. Then taking it out and drying it at normal temperature.	60°C,90%RH 96hrs	1,2
Thermal Shock Resistance	The sample should be allowed stand the following 10 cycles of operation 	-30°C/85°C 10 cycles	-
Vibration Test	Endurance test applying the vibration during transportation and using	Total fixed amplitude: 15mm; Vibration: 10~55Hz; One cycle 60 seconds to 3 directions of X, Y, Z, for each 16 minutes.	3
Static Electricity Test	Endurance test apply the electric stress to the terminal.	VS=800V, RS=1.5kΩ, CS=100pF, 1 time.	-

Note1: No dew condensation to be observed.

Note2: The function test shall be conducted after 4 hours storage at the normal. Temperature and humidity after remove from the rest chamber.

Note3: The packing have to including into the vibration testing.

12 Warranty and Conditions

<http://www.displaymodule.com/pages/faq>