

DM-LCD240128-474

240 × 128 STN(-) BLUE GRAPHIC
LCD WITH PARALLEL - MPU

Contents

- 1 Revision History
- 2 Main Features
- 3 Pin Description
- 4 Mechanical Drawing
 - 4.1 Panel Mechanical Drawing
- 5 Optics & Electrical Characteristics
 - 5.1 Optical Characteristics
 - 5.2 Absolute Maximum Ratings
 - 5.3 DC Characteristics
 - 5.4 LED Backlight Characteristics
 - 5.5 AC Characteristics
 - 5.5.1 MPU Interface Timing:
 - 5.5.2 Driver Interface Timing:
 - 5.5.3 External Interface Timing:
- 6 BLOCK DIAGRAM OF LCM
- 7 Commands
- 8 Built-in Font Table
- 9 Reliability
- 10 Warranty and Conditions

1 Revision History

Date	Changes
2015-04-15	First release
2019-12-18	Second release

2 Main Features

Item	Specification	Unit
Resolution	240 x 128	dots
Display Mode	STN Negative, Blue, Transmissive	-
Module dimension	144.0 x 104.0 x 14.3(MAX)	mm
View area	114.0 x 64.0	mm
Active area	107.98 x 57.58	mm
Dot size	0.43 x 0.43	mm
Dot pitch	0.45 x 0.45	mm
Controller IC	RA6963	-
Interface	Parallel MPU Interface	-
Power Supply	5.0	V
View Direction	6:00	-
Duty	1/128	-
Backlight	White LED	-
Weight	186.4	g

3 Pin Description

Pin No.	Symbol	Function Description
1	Vss	Ground
2	Vdd	Power supply
3	Vo	Power supply for LCD driver
4	C/D	WR=L, C/D=H:Command Write C/D=L:Data write RD=L, C/D=H:Status Read C/D=L:Data read
5	/RD	Data read.Read data from RA6963 when RD=L
6	/WR	Data write. Write data into RA6963 when WR=L
7	DB0	Data bus line
8	DB1	Data bus line
9	DB2	Data bus line
10	DB3	Data bus line
11	DB4	Data bus line
12	DB5	Data bus line
13	DB6	Data bus line
14	DB7	Data bus line
15	/CE	L: Chip enable
16	/RESET	H: Normal ; L: Initialize RA6963
17	Vee	Negative voltage output
18	MD2	H:32 columns; L:40 columns
19	FS1	Pins for selection of font; H : 6 * 8 , L : 8 * 8
20	NC	No connection

4 Mechanical Drawing

4.1 Panel Mechanical Drawing

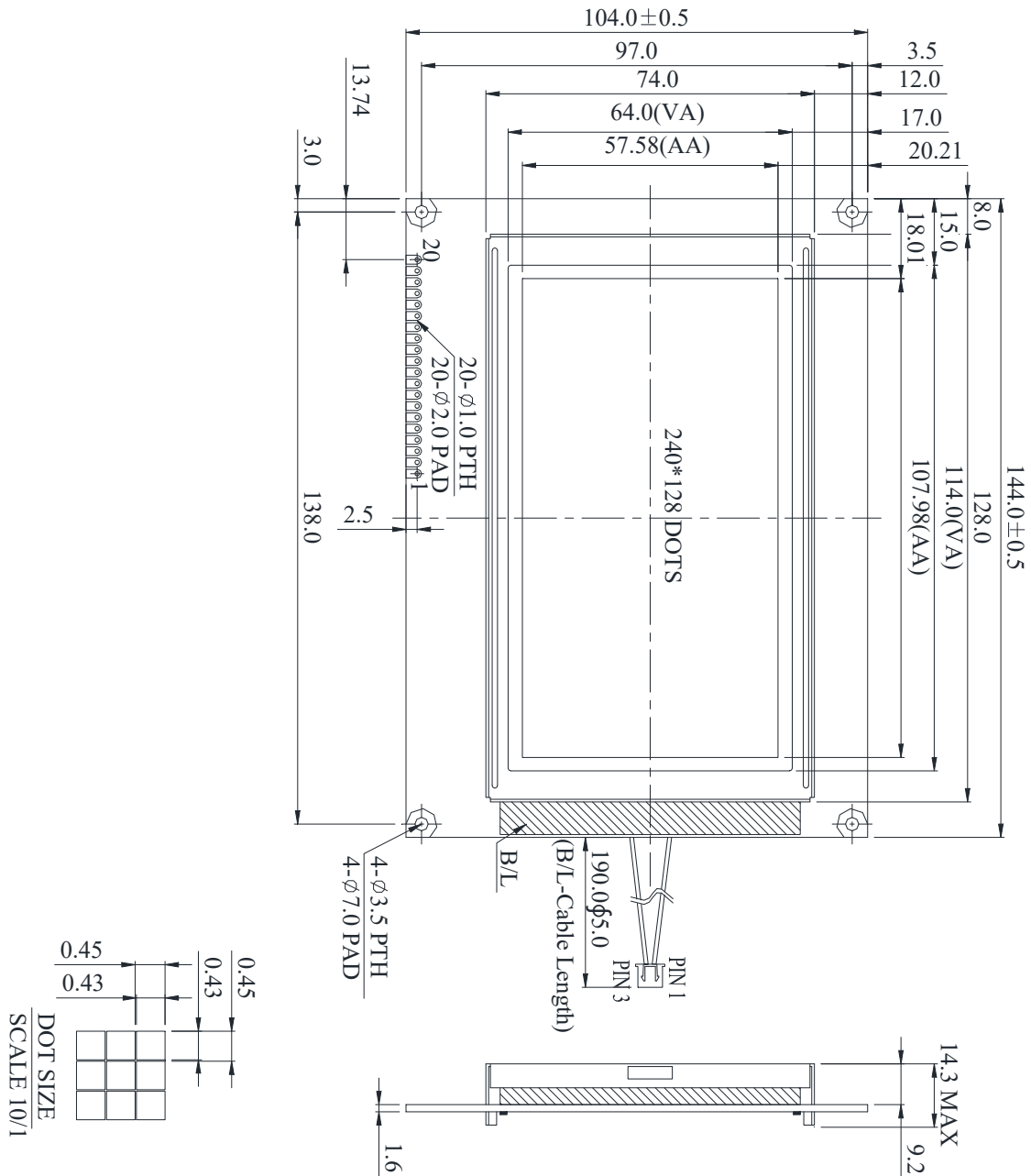

PIN NO.	SYMBOL
1	V _{SS}
2	V _{DD}
3	V _O
4	C/D
5	<u>RD</u>
6	<u>WR</u>
7	DB0
8	DB1
9	DB2
10	DB3
11	DB4
12	DB5
13	DB6
14	DB7
15	<u>CE</u>
16	<u>RESET</u>
17	V _{CC}
18	MD2
19	FS1
20	NC

5 Optics & Electrical Characteristics

5.1 Optical Characteristics

Item	Symbol	Min	Typ	Max	Unit	Note
View Angles	$\Theta=180^\circ$	0	-	20	°	CR \geq 2
	$\Theta=0^\circ$	0	-	40	°	
	$\Theta=90^\circ$	0	-	30	°	
	$\Theta=270^\circ$	0	-	30	°	
Response Time (25°C)	T _r	-	150	200	ms	
	T _f	-	150	200	ms	
Contrast Ratio	CR	-	3	-	-	

5.2 Absolute Maximum Ratings

Parameter	Symbol	Min	Max	Unit
Input Voltage	V _{IN}	-0.3	V _{DD} +0.3	V
Supply Voltage For Logic	V _{DD} -V _{SS}	-0.3	+7.0	V
Operating Temperature	T _{OP}	-20	70	°C
Storage Temperature	T _{STG}	-30	80	°C

5.3 DC Characteristics

Item	Symbol	Condition	Min	Typ.	Max	Unit
Supply Voltage For Logic	V _{DD} -V _{SS}		3.0	-	5.5	V
Supply Voltage For LCD (*Note)	V _{DD} -V ₀	T _a =-20°C	-	-	21.6	V
		T _a =25°C	18.9	19.5	20.1	V
		T _a =70°C	17.8	-	-	V
Supply Current	I _{DD}		42.0	55.0	60.0	mA
Low Level Input Voltage	V _{IL}		0	-	0.2V _{DD}	V
High Level Input Voltage	V _{IH}		0.8V _{DD}	-	V _{DD}	V
Low Level Output Voltage	V _{OL}		0		0.3	V
High Level Output Voltage	V _{OH}		V _{DD} -0.3		V _{DD}	V

Note: Please design the VOP adjustment circuit on customer's main board

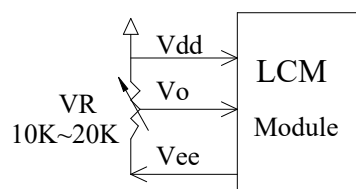

5.4 LED Backlight Characteristics

Parameter	Symbol	Min	Typ	Max	Unit	TEST CONDITION
Supply Current	I _{LED}	-	60	85	mA	V=3.5V
Supply Voltage	V	3.4	3.5	3.6	V	-
Reverse Voltage	V _R	-	-	5	V	-
Luminance (Without LCD)	I _V	260	320	-	cd/m ²	I _{LED} =60mA
LED Life Time (For Reference only)	-	-	50K	-	Hr.	I _{LED} =60mA 25°C,50-60%RH, (*Note)
Color	White					

Note : The LED of B/L is drive by current only, drive voltage is for reference only. drive voltage can make driving current under safety area (current between minimum and maximum).

*Note: 50K hours is only an estimate for reference.

LED B/L Drive Method

1. Drive from A , K

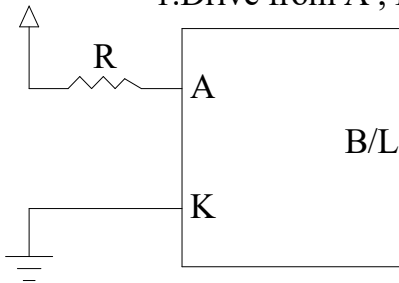

5.5 AC Characteristics

5.5.1 MPU Interface Timing:

Symbol	Description	Min	Max	Unit
t_{CDS}	$\overline{C/D}$ Set Up Time	100	-	ns
t_{CDH}	$\overline{C/D}$ Hold Time	10	-	ns
t_{CE}, t_{RD}, t_{WR}	$\overline{CE}, \overline{RD}, \overline{WR}$ Pulse Width	80	-	ns
t_{DS}	Data Set Up Time	80	-	ns
t_{DH}	Data Hold Time	40	-	ns
t_{ACC}	Access Time	-	150	ns
t_{OH}	Output Hold Time	10	50	ns

($V_{DD}=+5V\pm 5\%$, $GND=0V$, $T_a = -20$ to $+70^\circ C$)

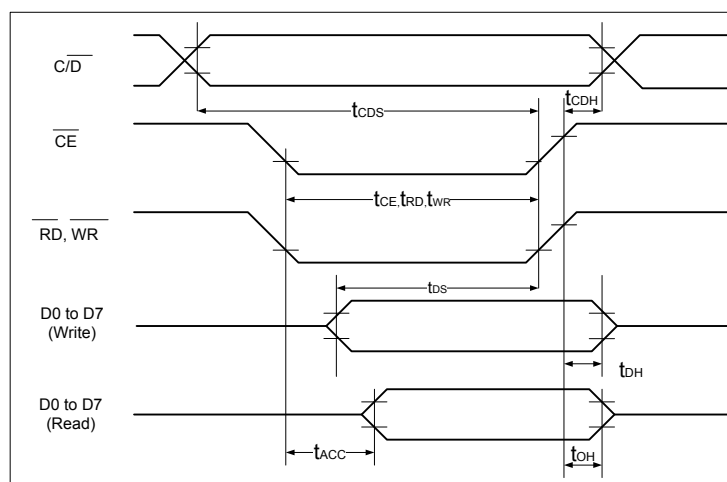

5.5.2 Driver Interface Timing:

Symbol	Description	Min	Max	Unit
f_{SCP}	Operating Frequency	-	9	MHz
t_{CWH}, t_{CWL}	SCP Pulse Width	150	-	ns
t_r, t_f	SCP Rise/Fall Time	-	30	ns
t_{LSU}	LP Setup Time	150	290	ns
t_{LHD}	LP Hold Time	5	40	ns
t_{DSU}	Data Setup Time	170	--	ns
t_{DHD}	Data Hold Time	80	--	ns
t_d	FR Delay Time	0	90	ns
t_{CSU}	CDATA Setup Time	450	850	ns
t_{CHD}	CDATA Hold Time	450	950	ns
t_{PWHR}	Read High Time	60	-	ns
t_{PWHW}	Write High Time	60	-	ns
t_{CS}	Chip Select Setup Time	0	-	ns
t_{CSH}	Chip Select Hold Time to Read Signal	0	-	ns
t_{CSF}	Chip Select Hold Time	20	-	ns
t_R	Rise Time	-	15	ns
t_F	Fall Time	-	15	ns

($V_{DD}=+5V\pm 5\%$, $GND=0V$, $T_a = -20$ to $+70^\circ C$)

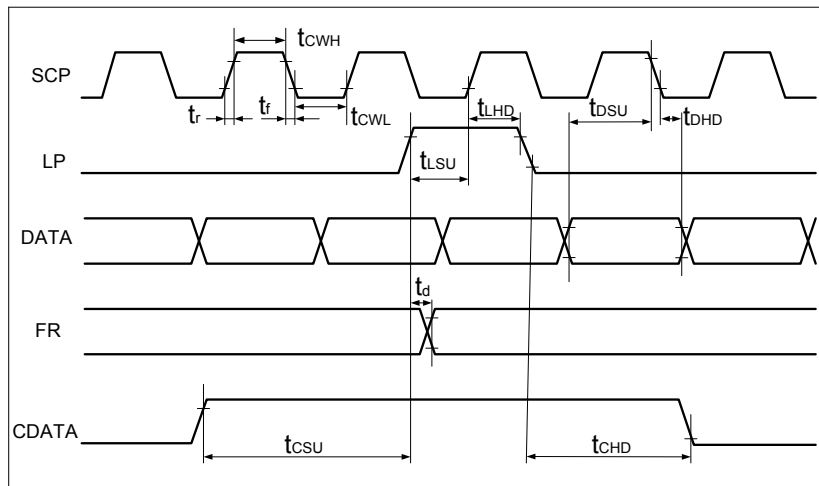

5.5.3 External Interface Timing:

Symbol	Description	Min	Max	Unit
t_{d1}	Address Delay Time	-	250	ns
t_{d2}	\overline{MCE} Fall Delay Time(Read)	-	180	ns
t_{d3}	\overline{MCE} Rise Delay Time(Read)	-	180	ns
t_{DS}	Data Setup Time	-	-	ns
t_{DH}	Data Hold Time	-	-	ns
t_{d4}	\overline{MCE} Fall Delay Time(Write)	-	200	ns
t_{d5}	\overline{MCE} Rise Delay Time(Write)	-	200	ns
t_{d6}	MRW Fall Delay Time	-	180	ns
t_{d7}	MRW Rise Delay Time	-	180	ns
t_{d8}	Data Stable Time	-	450	ns
t_{d9}	Data Hold Time	-	200	ns

($V_{DD}=+5V\pm 5\%$, $GND=0V$, $T_a= -20$ to $+70^\circ C$)

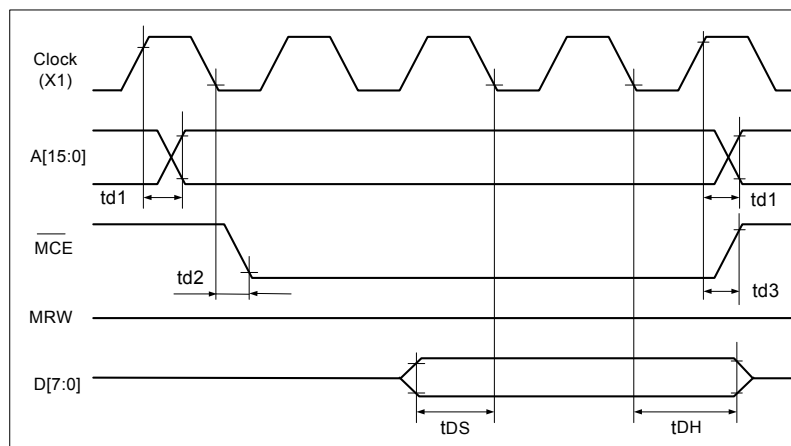
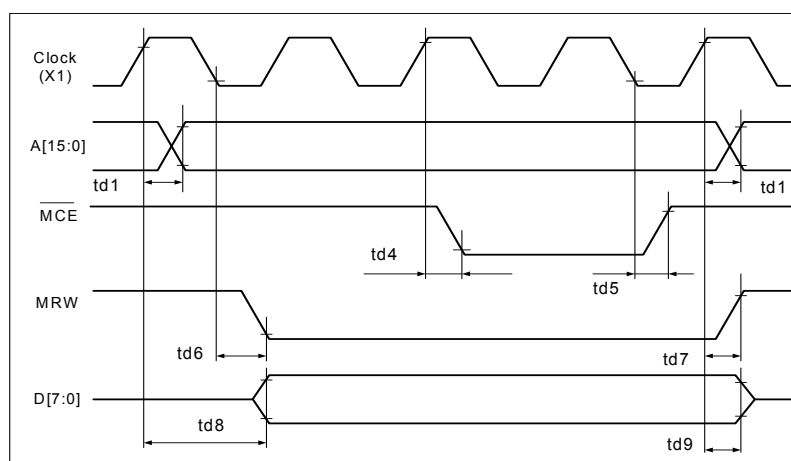
External RAM Read

External RAM Write

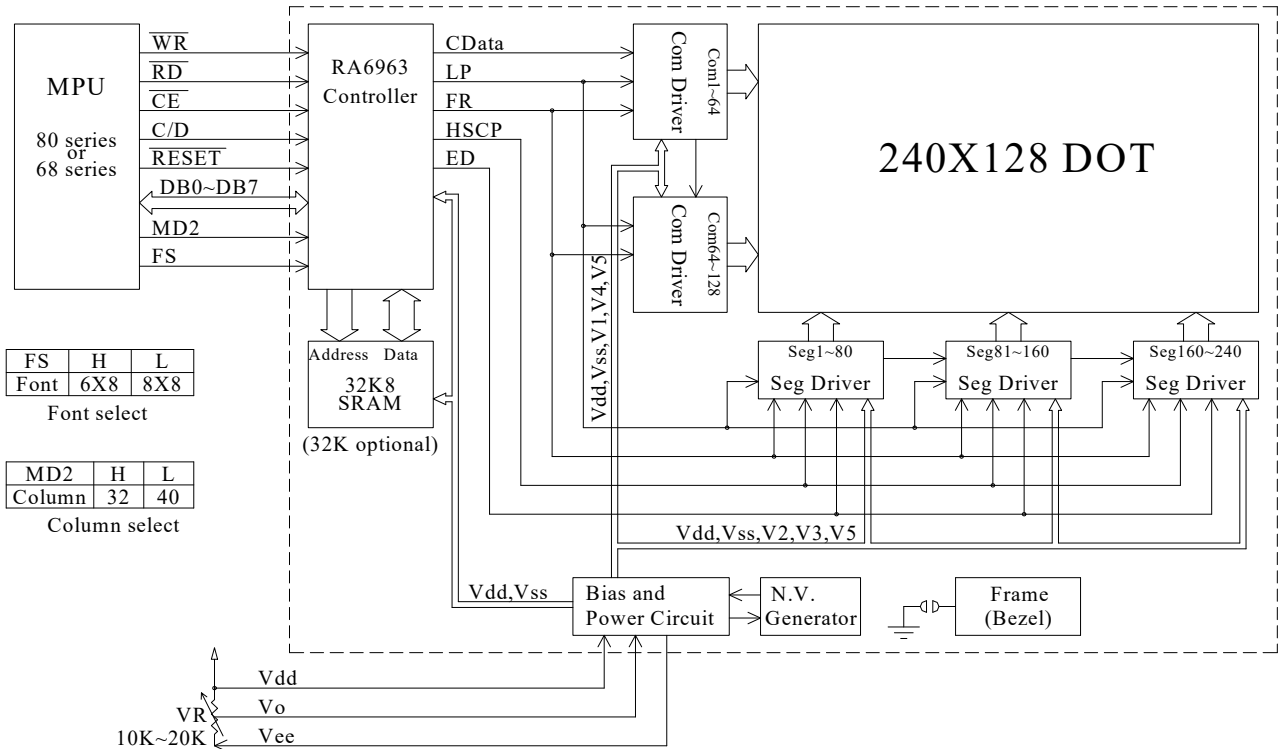
6 BLOCK DIAGRAM OF LCM



External contrast adjustment.

7 Commands

Command	Code	D1	D2	Function
Registers Setting	00100001	X address	Y address	Set cursor pointer Set Offset Register Set Address pointer
	00100010	Data	00h	
	00100100	Low address	High address	
Set Control Word	01000000	Low address	High address	Set Text Home Address Set Text Area Set Graphic Home Address Set Graphic Area
	01000001	Columns	00h	
	01000010	Low address	High address	
	01000011	Columns	00h	
Mode Set	1000X000	--	--	OR mode EXOR mode AND mode Text Attribute mode Internal CG ROM mode External CG RAM mode
	1000X001	--	--	
	1000X011	--	--	
	1000X100	--	--	
	1000XXX	--	--	
	1001XXX	--	--	
Display Mode	10010000	--	--	Display off Cursor on, blink off Cursor on, blink on Text on, graphic off Text off, graphic on Text on, graphic on
	1001XX10	--	--	
	1001XX11	--	--	
	100101XX	--	--	
	100110XX	--	--	
	100111XX	--	--	
Cursor Pattern Select	10100000	--	--	1-line cursor 2-line cursor 3-line cursor 4-line cursor 5-line cursor 6-line cursor 7-line cursor 8-line cursor
	10100001	--	--	
	10100010	--	--	
	10100011	--	--	
	10100100	--	--	
	10100101	--	--	
	10100110	--	--	
	10100111	--	--	
Data Read/Write	11000000	Data	--	Data Write and Increment ADP Data Read and Increment ADP Data Write and Decrement ADP Data Read and Decrement ADP Data Write and Non- variable ADP Data Read and Non-variable ADP
	11000001	--	--	
	11000010	Data	--	
	11000011	--	--	
	11000100	Data	--	
	11000101	--	--	
Data auto Read/Write	10110000	--	--	Set Data Auto Write Set Data Auto Read Auto Reset
	10110001	--	--	
	10110010	--	--	
Screen Peek	11100000	--	--	Screen Peek
Screen Copy	11101000			Screen Copy
Bit Set/Reset	11110XXX	--	--	Bit Reset Bit Set Bit 0 (LSB) Bit 1 Bit 2 Bit 3 Bit 4 Bit 5 Bit 6 Bit 7 (MSB)
	11111XXX	--	--	
	1111X000	--	--	
	1111X001	--	--	
	1111X010	--	--	
	1111X011	--	--	
	1111X100	--	--	
	1111X101	--	--	
	1111X110	--	--	
	1111X111	--	--	
Screen Reverse	11010000	Data	--	Whole screen reverse Data Bit 0 : Normal 1: Reverse

Blink Time	01010000	Data	Don't care (Note)	If Frame = 60Hz Data Bit 2:0 000 : 0.066s 001 : 0.25s 010 : 0.5s (Default) 011 : 0.75s 100 : 1s 101 : 1.25s 110 : 1.5s 111 : 2s
Cursor Moving Auto	01100000	Data	Don't care (Note)	Data Bit 0 : Disable.(Default) : Enable.
CGROM Font Select	01110000	Data	Don't care (Note)	Data Bit 1:0 00 : Do not care.(Default) 01 : Do not care. : CGROM Font-01. : CGROM Font-02.

Note: In these functions, it must be sent two data before sending the command, but the contents of the second datum (D2) can be any values.

8 Built-in Font Table

CGROM Font - 01

LSB \ MSB	0	1	2	3	4	5	6	7	8	9	A	B	C	D	E	F
0		!	"	#	\$	%	&	'	()	*	+	,	-	.	/
1	0	1	2	3	4	5	6	7	8	9	:	;	<	=	>	?
2	a	A	B	C	D	E	F	G	H	I	J	K	L	M	N	O
3	P	Q	R	S	T	U	V	W	X	Y	Z	[\]	^	_
4	`	a	b	c	d	e	f	g	h	i	j	k	l	m	n	o
5	p	q	r	s	t	u	v	w	x	y	z	{		}	~	
6	0	1	2	3	4	5	6	7	8	9	a	b	c	d	e	f
7	0	1	2	3	4	5	6	7	8	9	a	b	c	d	e	f

CGROM Font - 02

LSB \ MSB	0	1	2	3	4	5	6	7	8	9	A	B	C	D	E	F
0		!	"	#	\$	%	&	'	()	*	+	,	-	.	/
1	0	1	2	3	4	5	6	7	8	9	:	;	<	=	>	?
2	a	A	B	C	D	E	F	G	H	I	J	K	L	M	N	O
3	P	Q	R	S	T	U	V	W	X	Y	Z	[\]	^	_
4	`	a	b	c	d	e	f	g	h	i	j	k	l	m	n	o
5	p	q	r	s	t	u	v	w	x	y	z	{		}	~	
6	0	1	2	3	4	5	6	7	8	9	a	b	c	d	e	f
7	0	1	2	3	4	5	6	7	8	9	a	b	c	d	e	f

9 Reliability

Test Item	Content of Test	Test Condition	Note
High Temperature Storage	Endurance test applying the high storage temperature for a long time.	80°C 200hrs	2
Low Temperature Storage	Endurance test applying the high storage temperature for a long time.	-30°C 200hrs	1,2
High Temperature Operation	Endurance test applying the electric stress (Voltage & Current) and the thermal stress to the element for a long time.	70°C 200hrs	-
Low Temperature Operation	Endurance test applying the electric stress under low temperature for a long time.	-20 °C 200hrs	1
High Temperature/ Humidity Operation	The module should be allowed to stand at 60°C,90%RH max, for 96hrs under no-load condition excluding the polarizer. Then taking it out and drying it at normal temperature.	60°C,90%RH 96hrs	1,2
Thermal Shock Resistance	The sample should be allowed stand the following 10 cycles of operation	-20°C/70°C 10 cycles	-

Note1: No dew condensation to be observed.

Note2: The function test shall be conducted after 4 hours storage at the normal. Temperature and humidity after remove from the rest chamber.

10 Warranty and Conditions

<http://www.displaymodule.com/pages/faq> HYPERLINK

"http://www.displaymodule.com/pages/faq"