

# DisplayModule

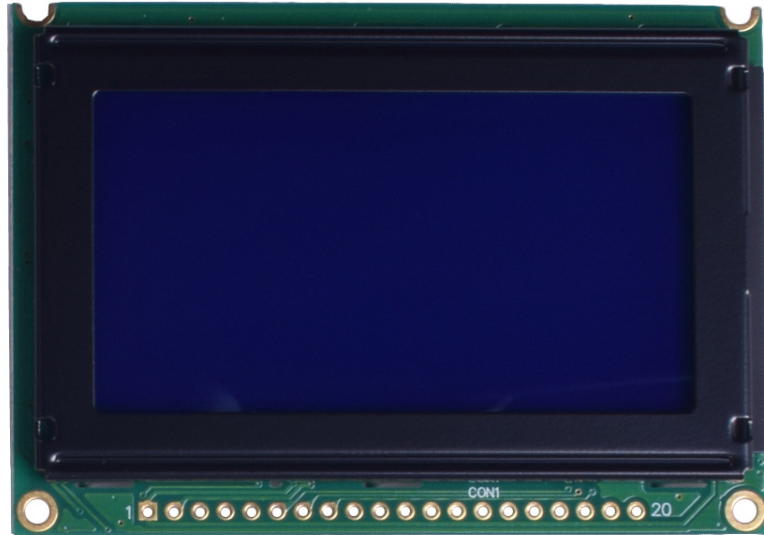

**DM-LCD12864-458**  
**12864 STN(-) BLUE GRAPHIC LCD**  
**WITH PARALLEL MPU INTERFACE**

## Contents

[Revision History](#)

[Main Features](#)

[Pin Description](#)

[Mechanical Drawing](#)

[Electrical Characteristics](#)

[Optical Characteristics](#)

[Block Diagram](#)

[Timing Characteristics](#)

[Commands](#)

[Driver/Controller Information](#)

[Reliability](#)

[Warranty and Conditions](#)

## 1 Revision History

Date	Changes
2015-04-15	First release

## 2 Main Features

Item	Specification	Unit
Resolution	128 x 64	dots
Display Mode	STN Negative,Blue, Transmissive	-
Module dimension	75.0 x 52.7 x 8.9 (MAX)	mm
Controller IC	NT7108	-
Interface	Parallel MPU Interface	-
Power Supply	5.0	V
View Direction	6:00	-
Duty	1/64	
Backlight	White LED	-
Weight	34.8	g

## 3 Pin Description

Pin No.	Symbol	Description
1	VDD	Power Supply for logic
2	VSS	Ground
3	Vo	Contrast Adjustment(Variable)
4	DB0	Data bus line
5	DB1	Data bus line
6	DB2	Data bus line
7	DB3	Data bus line
8	DB4	Data bus line
9	DB5	Data bus line
10	DB6	Data bus line
11	DB7	Data bus line
12	CS1	Select Column 1~ Column 64
13	CS2	Select Column 65~ Column 128
14	/RST	Reset signal
15	R/W	H: Read (MPU←Module) , L: Write (MPU→Module)
16	D/I	H: Data , L : Instruction
17	E	Enable signal
18	Vee	Negative Voltage output (Vout)
19	A	Power Supply for LED backlight ( + )
20	K	Power Supply for LED backlight ( - )

## 4 Mechanical Drawing

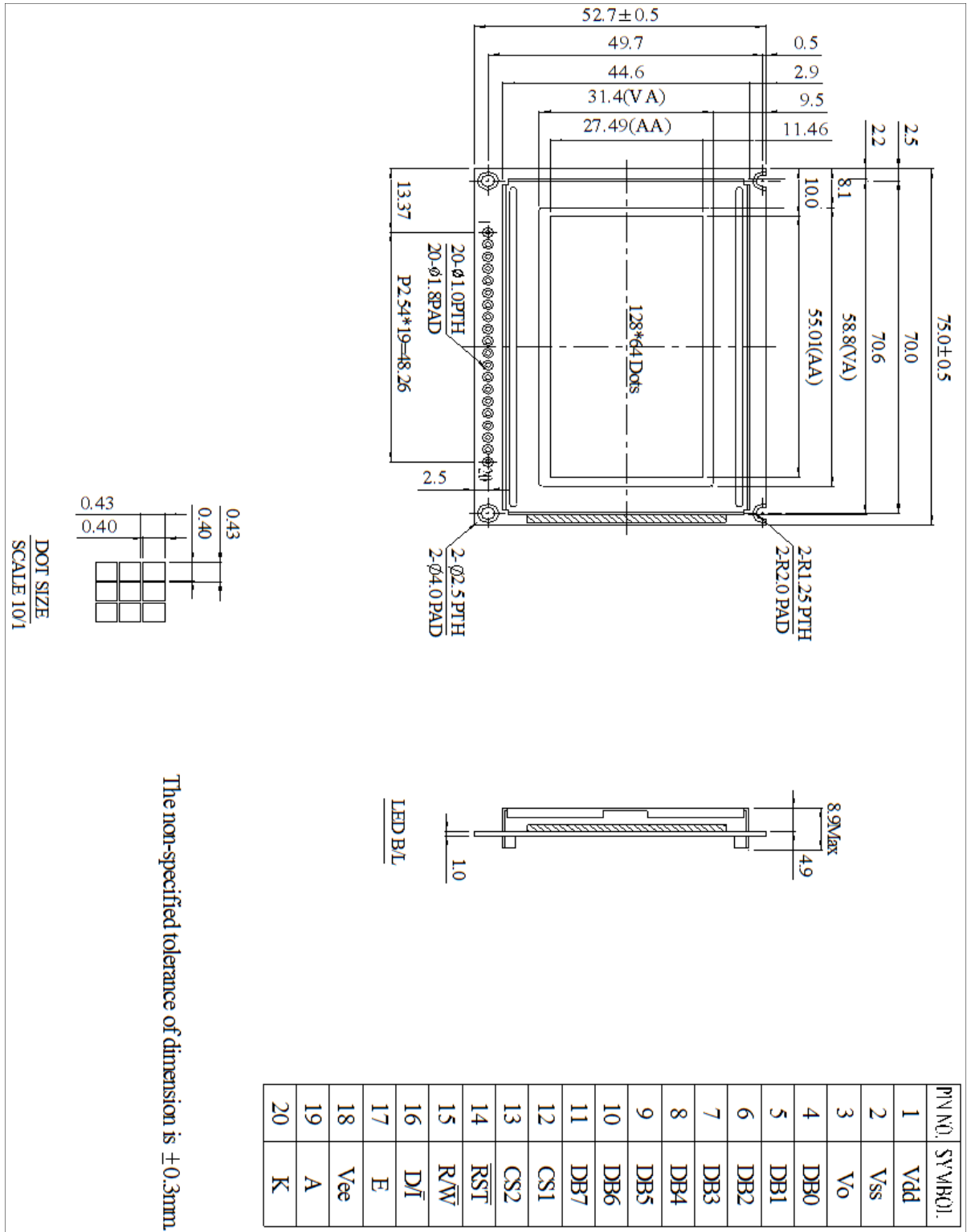

## 5 Electrical Characteristics

Item	Symbol	Condition	Min	Typ.	Max	Unit
Supply Voltage For Logic	VDD		4.5	5.0	5.5	V
Supply Current	IDD	VDD=5.0V	3.0	4.0	5.0	mA
Low Level Input Voltage	V <sub>IL</sub>		0	-	0.8	V
High Level Input Voltage	V <sub>IH</sub>		0.7VDD	-	VDD	V
Low Level Output Voltage	V <sub>OL</sub>		0		0.4	V
High Level Output Voltage	V <sub>OH</sub>		2.4		-	V
Backlight Supply Voltage	V		3.4	3.5	3.6	V
Backlight Supply Current	I <sub>LED</sub>		43.2	48	60	mA
Operating Temperature	TOP	Absolute Max	-20	-	+70	°C
Storage Temperature	TST	Absolute Max	-30	-	+80	°C

## 6 Optical Characteristics

Item	Symbol	Min	Typ	Max	Unit	Note
View Angles Top	AV		20		°	
View Angles Bottom	AV		40		°	
View Angles Left	AH		30		°	
View Angles Right	AH		30		°	
Response Time (25°C)	Tr + Tf		300	400	ms	
Contrast Ratio	CR		3			
Luminance ( Without LCD)	Ly	416	520		cd/m <sup>2</sup>	

## 7 Block Diagram

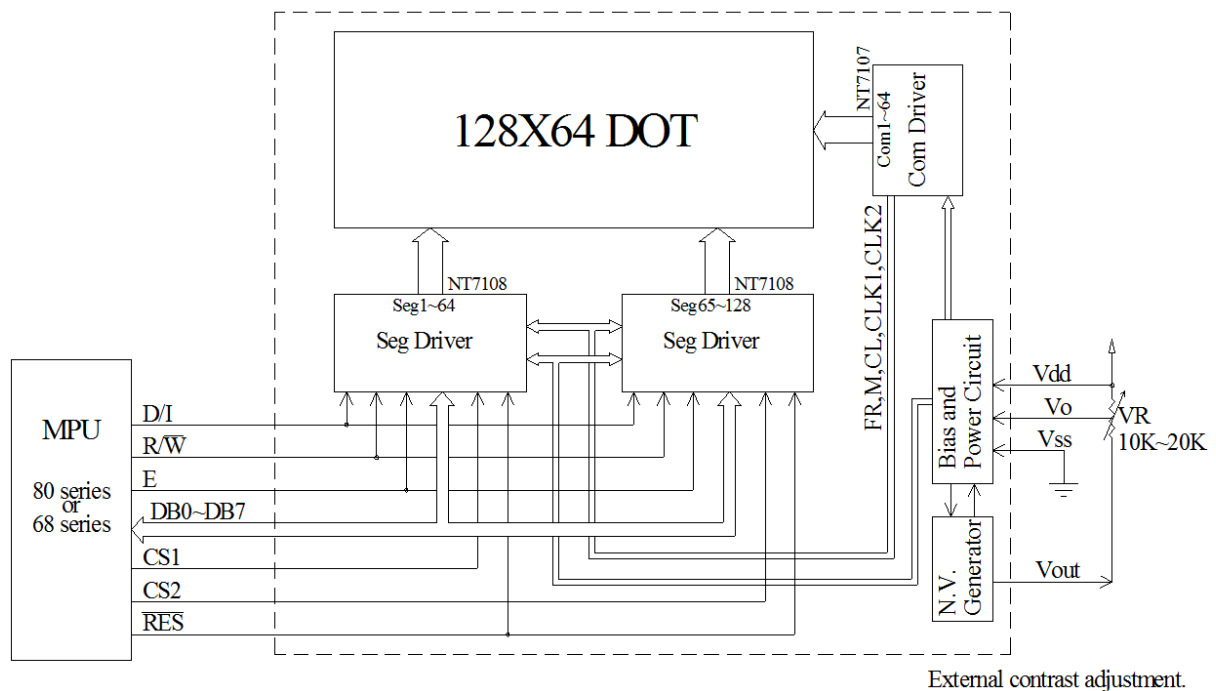

## 8 Timing Characteristics

Symbol	Parameter	Min	Typ	Max	Unit
$t_C$	E cycle	1000	-	-	ns
$t_{WH}$	E high level width	450	-	-	ns
$t_{WL}$	E low level width	450	-	-	ns
$t_R$	E rise time	-	-	25	ns
$t_F$	E fall time	-	-	25	ns
$t_{ASU}$	Address set-up time	140	-	-	ns
$t_{AH}$	Address hold time	10	-	-	ns
$t_{DSU}$	Data set-up time	200	-	-	ns
$t_D$	Data delay time	-	-	320	ns
$t_{DHW}$	Data hold time (write)	10	-	-	ns
$t_{DHR}$	Data hold time (read)	20	-	-	ns

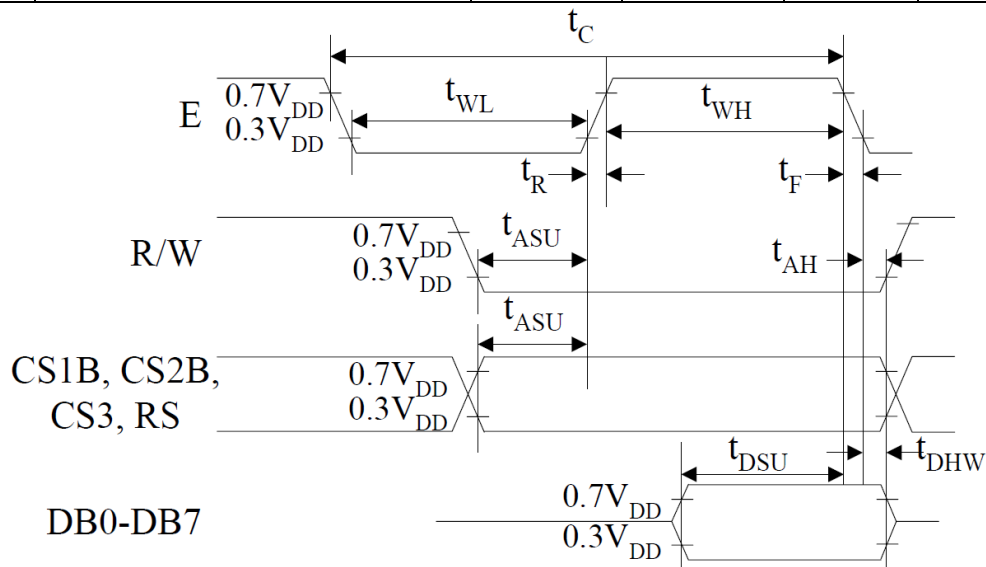

MPU Write Timing

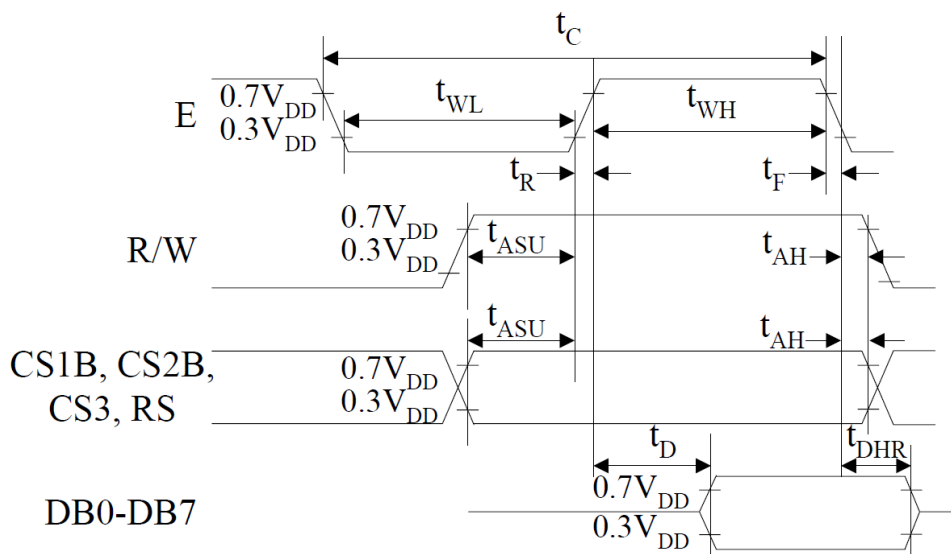

MPU Read Timing

## 9 Commands

Instruction	RS	R/W	DB7	DB6	DB5	DB4	DB3	DB2	DB1	DB0	Function	
Display on/off	L	L	L	L	H	H	H	H	H	L/H	Controls the display on or off. Internal status and display RAM data is not affected. L:OFF, H:ON	
Set address (Y address)	L	L	L	H	Y address (0-63)						Sets the Y address in the Y address counter.	
Set page (X address)	L	L	H	L	H	H	H	Page (0-7)			Sets the X address at the X address register.	
Display Start line (Z address)	L	L	H	H	Display start line (0-63)						Indicates the display data RAM displayed at the top of the screen.	
Status read	L	H	Busy	L	On/Off	Reset	L	L	L	L	Read status. BUSY L: Ready H: In operation ON/OFF L: Display ON H: Display OFF RESET L: Normal H: Reset	
Write display data	H	L	Write data									Writes data (DB0: 7) into display data RAM. After writing instruction, Y address is increased by 1 automatically.
Read display data	H	H	Read data									Reads data (DB0: 7) from display data RAM to the data bus.

### DISPLAY ON/OFF

RS	R/W	DB7	DB6	DB5	DB4	DB3	DB2	DB1	DB0
0	0	0	0	1	1	1	1	1	D

The display data appears when D is 1 and disappears when D is 0. Though the data is not on the screen with D=0, it remains in the display data RAM. Therefore, you can make it appear by changing D=0 into D=1.

### SET ADDRESS(Y ADDRESS)

RS	R/W	DB7	DB6	DB5	DB4	DB3	DB2	DB1	DB0
0	0	0	1	AC5	AC4	AC3	AC2	AC1	AC0

Y address (AC0-AC5) of the display data RAM is set in the Y address counter. An address is set by instruction and increased by 1 automatically by read or write operations of display data.

### SET PAGE (X ADDRESS)

RS	R/W	DB7	DB6	DB5	DB4	DB3	DB2	DB1	DB0
0	0	1	0	1	1	1	AC2	AC1	AC0

X address (AC0-AC2) of the display data RAM is set in the X address register. Writing or reading to or from MPU is executed in this specified page until the next page is set.

### DISPLAY START LINE(Z ADDRESS)

RS	R/W	DB7	DB6	DB5	DB4	DB3	DB2	DB1	DB0
0	0	1	1	AC5	AC4	AC3	AC2	AC1	AC0

Z address (AC0-AC5) of the display data RAM is set in the display start line register and displayed at the top of the screen. When the display duty cycle is 1/64 or others (1/32-1/64), the data of total line number of LCD screen, from the line specified by display start line instruction, is displayed.

### STATUS READ

RS	R/W	DB7	DB6	DB5	DB4	DB3	DB2	DB1	DB0
0	1	BUSY	0	ON/OFF	RESET	0	0	0	0

**·BUSY**

When BUSY is 1, the Chip is executing internal operation and no instructions are accepted.

When BUSY is 0, the Chip is ready to accept any instructions.

**·ON/OFF**

When ON/OFF is 1, the display is OFF.

When ON/OFF is 0, the display is ON.

**·RESET**

When RESET is 1, the system is being initialized.

In this condition, no instructions except status read can be accepted.

When RESET is 0, initializing has finished and the system is in usual operation condition.

**WRITE DISPLAY DATA**

RS	R/W	DB7	DB6	DB5	DB4	DB3	DB2	DB1	DB0
1	0	D7	D6	D5	D4	D3	D2	D1	D0

Writes data (D0-D7) into the display data RAM. After writing instruction, Y address is increased by 1 automatically.

**READ DISPLAY DATA**

RS	R/W	DB7	DB6	DB5	DB4	DB3	DB2	DB1	DB0
1	1	D7	D6	D5	D4	D3	D2	D1	D0

Reads data (D0-D7) from the display data RAM. After reading instruction, Y address is increased by 1 automatically.

## 10 Driver/Controller Information

Built-in NT7108 IC

<https://drive.google.com/file/d/0B5IkVYnewKTGZ1d0RjVvX1BXRik/view?usp=sharing>

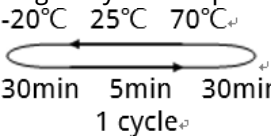

## 11 Reliability

Test Item	Content of Test	Test Condition	Note
High Temperature Storage	Endurance test applying the high storage temperature for a long time.	80°C 200hrs	2
Low Temperature Storage	Endurance test applying the high storage temperature for a long time.	-30°C 200hrs	1,2
High Temperature Operation	Endurance test applying the electric stress (Voltage & Current) and the thermal stress to the element for a long time.	70°C 200hrs	-
Low Temperature Operation	Endurance test applying the electric stress under low temperature for a long time.	-20 °C 200hrs	1
High Temperature/ Humidity Operation	The module should be allowed to stand at 60°C,90%RH max, for 96hrs under no-load condition excluding the polarizer. Then taking it out and drying it at normal temperature.	60°C,90%RH 96hrs	1,2
Thermal Shock Resistance	The sample should be allowed stand the following 10 cycles of operation. 	-20°C/70°C 10 cycles	-
Vibration Test	Endurance test applying the vibration during transportation and using.	Total fixed amplitude: 15mm; Vibration: 10~55Hz; One cycle 60 seconds to 3 directions of X, Y, Z, for each 16 minutes.	3
Static Electricity Test	Endurance test apply the electric stress to the terminal.	VS=800V, RS=1.5kΩ, CS=100pF, 1 time.	-

Note1: No dew condensation to be observed.

Note2: The function test shall be conducted after 4 hours storage at the normal. Temperature and humidity after remove from the rest chamber.

Note3: Test performed on product itself, not inside a container

## 12 Warranty and Conditions

<http://www.displaymodule.com/pages/faq>