

DM-LCD12232-451
12232 STN(+) Y/G GRAPHIC LCD
WITH PARALLEL MPU INTERFACE

Contents

[Revision History](#)

[Main Features](#)

[Pin Description](#)

[Mechanical Drawing](#)

[Electrical Characteristics](#)

[Optical Characteristics](#)

[Block Diagram](#)

[Timing Character](#)

[Commands](#)

[Driver/Controller Information](#)

[Reliability](#)

[Warranty and Conditions](#)

1 Revision History

Date	Changes
2015-04-15	First release

2 Main Features

Item	Specification	Unit
Resolution	122 x 32	dots
Display Mode	STN Positive, Yellow Green, Transflective	-
Module dimension	84.0 x 44.0 x 13.7 (MAX)	mm
Controller IC	SBN1661G	-
Interface	Parallel MPU interface	-
Power Supply	3.0	V
View Direction	6:00	-
Duty	1/32	
Backlight	Yellow Green LED	-
Weight	36.4	g

3 Pin Description

Pin No.	Symbol	Description
1	VSS	GND
2	VDD	Power Supply for logic
3	Vo	Contrast Adjustment
4	A0	H:Data L:Instruction
5	CS1	Chip enable IC1
6	CS2	Chip enable IC2
7	NC	No Connection
8	NC	No Connection
9	R/W	H:Read; L:Write(68 series MPU interface only)
10	DB0	Data bus line
11	DB1	Data bus line
12	DB2	Data bus line
13	DB3	Data bus line
14	DB4	Data bus line
15	DB5	Data bus line
16	DB6	Data bus line
17	DB7	Data bus line
18	RES	H→L: The LCM be reset
19	Vee	Negative Voltage Output
20	NC	No Connection

4 Mechanical Drawing

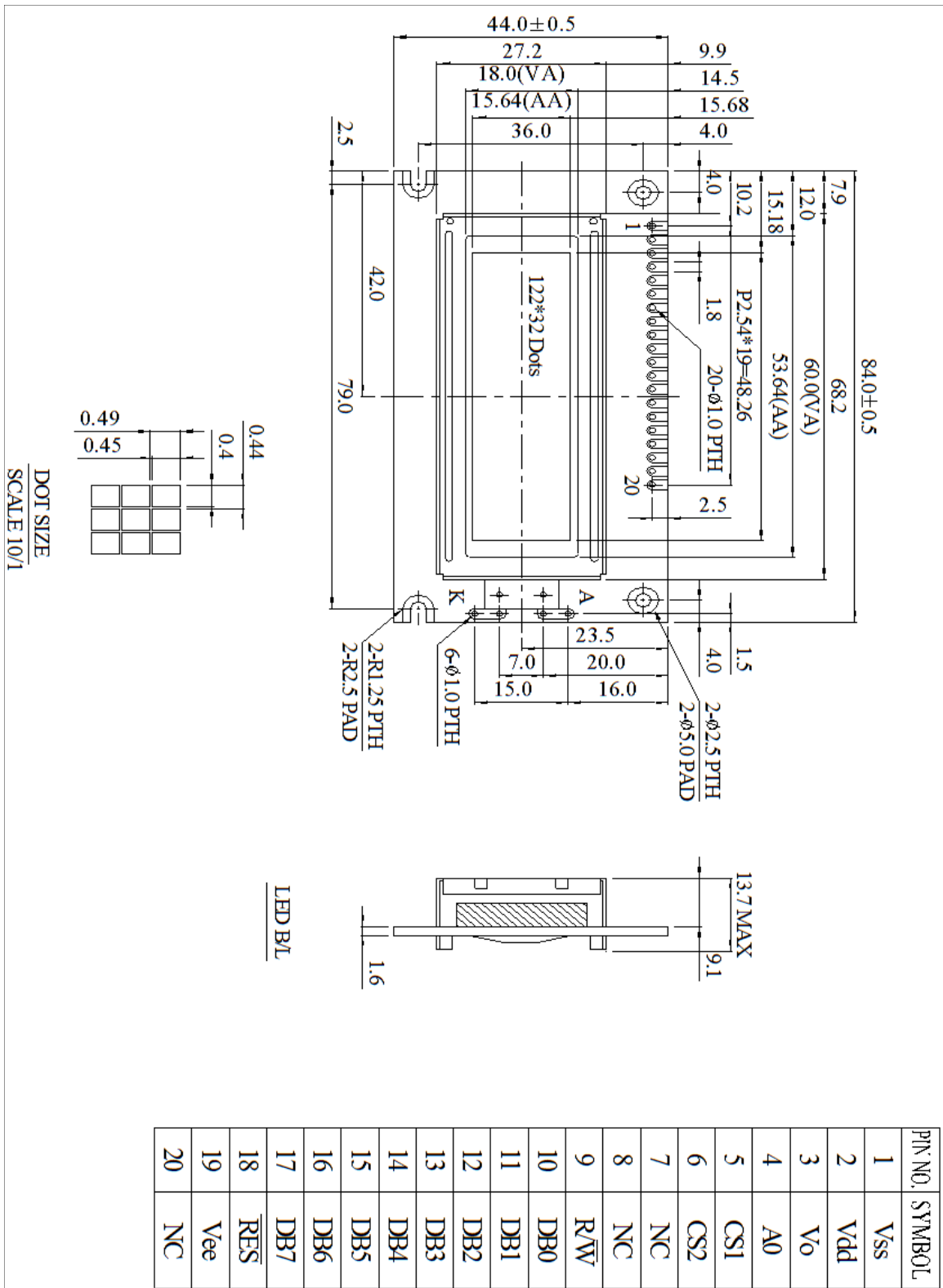

5 Electrical Characteristics

Item	Symbol	Condition	Min	Typ.	Max	Unit
Supply Voltage For Logic	VDD		2.7	3.0	3.3	V
Supply Current	IDD	VDD=5.0V	0.8	1.0	1.2	mA
Low Level Input Voltage	V _{IL}		0	-	0.7	V
High Level Input Voltage	V _{IH}		2.0	-	VDD	V
Low Level Output Voltage	V _{OL}		0		0.3	V
High Level Output Voltage	V _{OH}		VDD-0.3		VDD	V
Backlight Supply Voltage	V		4.0	4.2	4.5	V
Backlight Supply Current	I _{LED}		96	120	144	mA
Operating Temperature	TOP	Absolute Max	-20	-	+70	°C
Storage Temperature	TST	Absolute Max	-30	-	+80	°C

6 Optical Characteristics

Item	Symbol	Min	Typ	Max	Unit	Note
View Angles Top	AV		20		°	
View Angles Bottom	AV		40		°	
View Angles Left	AH		30		°	
View Angles Right	AH		30		°	
Response Time (25°C)	Tr + Tf		300	400	ms	
Contrast Ratio	CR		3			
Luminance (Without LCD)	Ly	160	180		cd/m ²	

7 Block Diagram

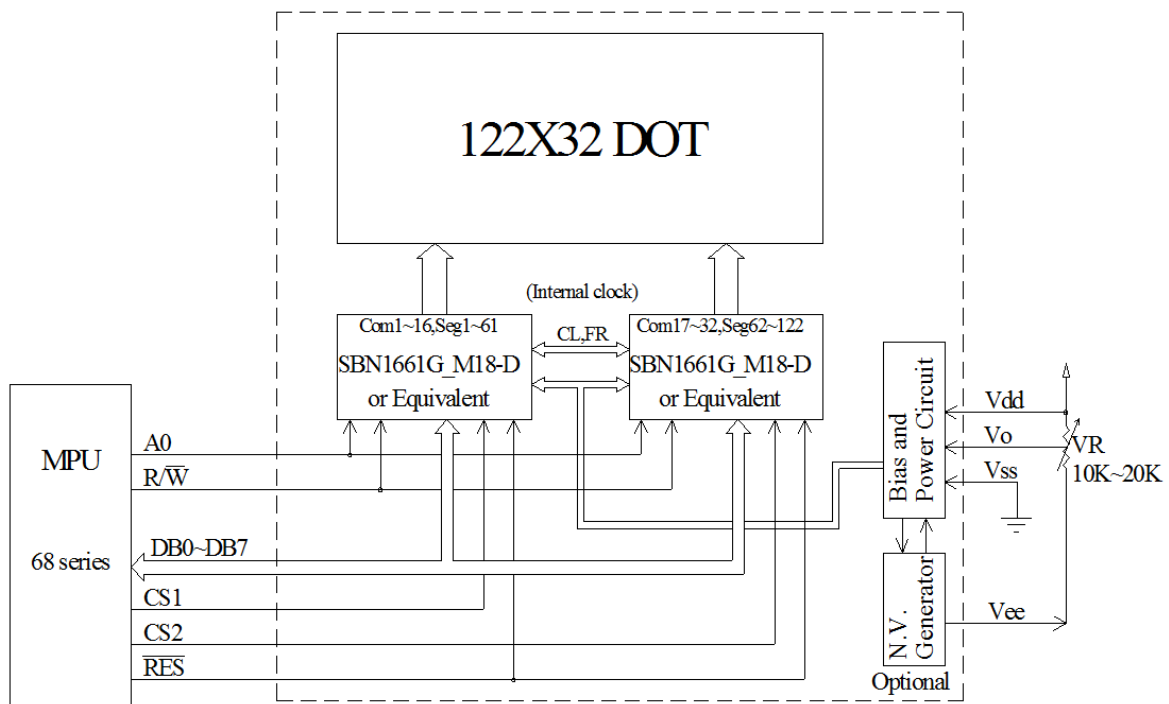

External contrast adjustment.

8 Timing Character

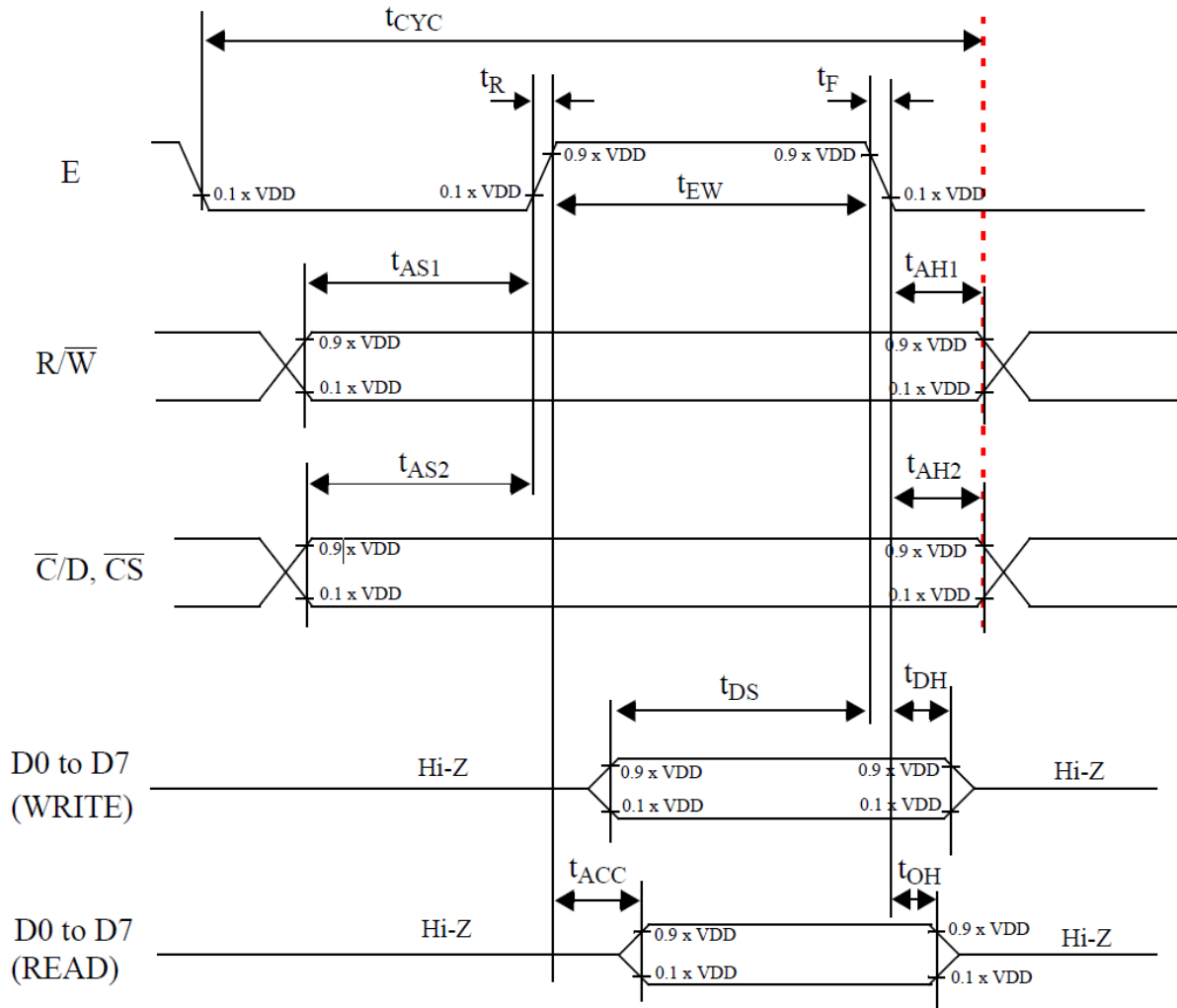

Symbol	Parameter	Min	Typ	Max	Unit
T_{AS1}	Address set-up time with respect to R/W	40	-	-	ns
T_{AS2}	Address set-up time with respect to C/D, CS	40	-	-	ns
T_{AH1}	Address hold time with respect to R/W	20	-	-	ns
T_{AH2}	Address hold time respect with to C/D, CS	20	-	-	ns
T_F, T_R	Enable (E) pulse falling/rising time	-	-	15	ns
T_{CYC}	System cycle time	2000	-	-	ns
T_{EWR}	Enable pulse width for READ	200	-	-	ns
T_{EWW}	Enable pulse width for WRITE	160	-	-	ns
T_{DS}	Data setup time	160	-	-	ns
T_{DH}	Data hold time	20	-	-	ns
T_{ACC}	Data access time	-	-	180	ns
T_{OH}	Data output hold time	20	-	120	ns

9 Commands

COMMAND	COMMAND CODE								FUNCTION
	D7	D6	D5	D4	D3	D2	D1	D0	
Write Display Data	Data to be written into the Display Data Memory.								Write a byte of data to the Display Data Memory.
Read Display Data	Data read from the Display Data Memory.								Read a byte of data from the Display Data Memory.
Read-Modify-Write	1	1	1	0	0	0	0	0	Start Read-Modify-Write operation.
END	1	1	1	0	1	1	1	0	Stop Read-Modify-Write operation.
Software Reset	1	1	1	0	0	0	1	0	Software Reset.

Write Display Data

The Write Display Data command writes a byte (8 bits) of data to the Display Data Memory. Data is put on the data bus by the host microcontroller. The location which accepts this byte of data is pointed to by the Page Address Register and the Column Address Register. At the end of the command operation, the content of the Column Address Register is automatically incremented by 1. Following table gives the control bus setting for this command.

C/D	E/(RD)	R/W(WR)
1	1	0

Read Display Data

The Read Display Data command starts a 3-step operation.

1. First, the current data of the internal 8-bit output latch of the Display Data Memory is read by the microcontroller, via the 8-bit data bus DB0~DB7.
2. Then, a byte of data of the Display Data Memory is transferred to the 8-bit output latch from a location specified by the Page Address Register and the Column Address Register,
3. Finally, the content of the Column Address Register is automatically incremented by one.

Following image shows the internal 8-bit output latch located between the 8-bit I/O data bus and the Display Data Memory cell array. Because of this internal 8-bit output latch, a dummy read is needed to obtain correct data from the Display Data Memory.

For Display Data Write operation, a dummy write is not needed, because data can be directly written from the data bus to internal memory cells.

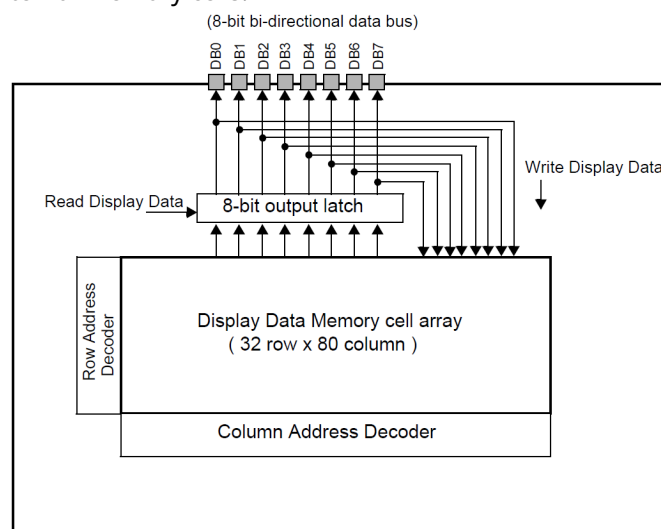

Following table gives the control bus setting for this command.

C/D	E/(RD)	R/W(WR)
1	0	1

Read-Modify-Write

When the Read-Modify-Write command is issued, the SBN1661G_X enters into Read-Modify-Write mode.

In normal operation, when a Read Display Data command or a Write Display Data command is issued, the content of the Column Address Register is automatically incremented by one after the command operation is finished. However, during Read-Modify-Write mode, the content of the Column Address Register is not incremented by one after a Read Display Data command is finished; only the Write Display Data command can make the content of the Column Address Register automatically incremented by one after the command operation is finished.

During Read-Modify-Write mode, any other registers, except the Column Address Register, can be modified. This command is useful when a block of the Display Data Memory needs to be repeatedly read and updated.

Following image gives the change sequence of the Column Address Register during Read-Modify-Write mode.

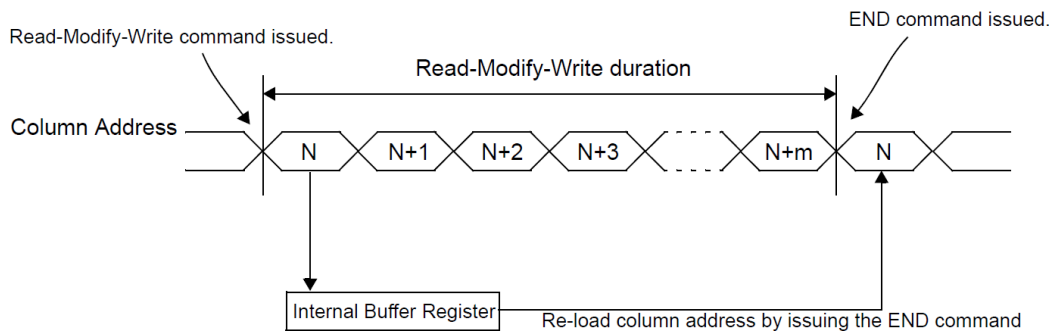

Following image gives the flow chart for Read-Modify-Write command.

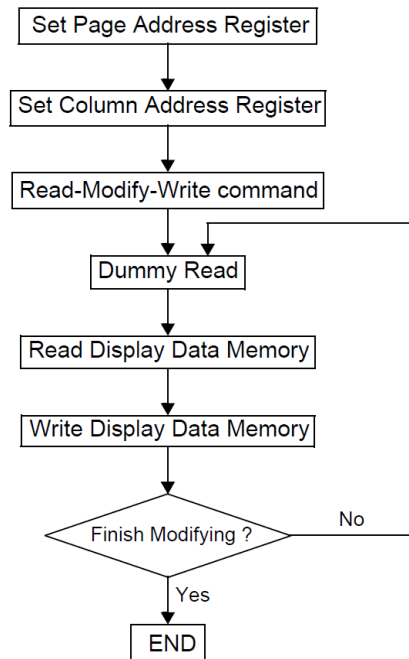

The setting of the control bus for the Read-Modify-Write command

C/D	E/(RD)	R/W(WR)
0	1	0

The setting of the data bus for the Read-Modify-Write command

D7(MSB)	D6	D5	D4	D3	D2	D1	D0(LSB)
1	1	1	0	0	0	0	0

The command code is E0 Hex.

The END command

The END command releases the Read-Modify-Write mode and re-loads the Column Address Register with the value previously stored in the internal buffer when the Read-Modify-Write command was issued.

The setting of the control bus for the END command

C/D	E/(RD)	R/W(WR)
0	1	0

The setting of the data bus for the END command

D7(MSB)	D6	D5	D4	D3	D2	D1	D0(LSB)
1	1	1	0	1	1	1	0

The command code is EE Hex.

Software RESET command

The Software Reset command is different from the hardware reset and can not be used to replace hardware reset.

When Software Reset is issued by the host microcontroller,

The content of the Display Start Line Register is cleared to zero(A4-A0=00000),

The Page Address Register is set to 3 (A1 A0 = 11),

The content of the Display Data Memory remains unchanged, and

The content of all other registers remains unchanged.

The setting of the control bus for Software RESET

C/D	E/(RD)	R/W(WR)
0	1	0

The setting of the data bus for Software RESET

D7(MSB)	D6	D5	D4	D3	D2	D1	D0(LSB)
1	1	1	0	0	1	1	0

The command code is E2 Hex.

10 Driver/Controller Information

Built-in SBN1661G IC

https://drive.google.com/file/d/0B_HGldxxTS9iZVA5bkdaUWhTQkE/view?usp=sharing

11 Reliability

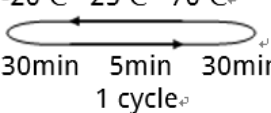
Test Item	Content of Test	Test Condition	Note
High Temperature Storage	Endurance test applying the high storage temperature for a long time.	80°C 200hrs	2
Low Temperature Storage	Endurance test applying the high storage temperature for a long time.	-30°C 200hrs	1,2
High Temperature Operation	Endurance test applying the electric stress (Voltage & Current) and the thermal stress to the element for a long time.	70°C 200hrs	-
Low Temperature Operation	Endurance test applying the electric stress under low temperature for a long time.	-20 °C 200hrs	1
High Temperature/ Humidity Operation	The module should be allowed to stand at 60°C,90%RH max, for 96hrs under no-load condition excluding the polarizer. Then taking it out and drying it at normal temperature.	60°C,90%RH 96hrs	1,2
Thermal Shock Resistance	The sample should be allowed stand the following 10 cycles of operation. 	-20°C/70°C 10 cycles	-
Vibration Test	Endurance test applying the vibration during transportation and using.	Total fixed amplitude: 15mm; Vibration: 10~55Hz; One cycle 60 seconds to 3 directions of X, Y, Z, for each 16 minutes.	3
Static Electricity Test	Endurance test apply the electric stress to the terminal.	VS=800V, RS=1.5kΩ, CS=100pF, 1 time.	-

Note1: No dew condensation to be observed.

Note2: The function test shall be conducted after 4 hours storage at the normal. Temperature and humidity after remove from the rest chamber.

Note3: Test performed on product itself, not inside a container

12 Warranty and Conditions

<http://www.displaymodule.com/pages/faq>