

DM-COG1602-717
1602 COG CHARACTER LCD WITH 4-
WIRE SERIAL INTERFACE

Contents

[Revision History](#)

[Main Features](#)

[Pin Description](#)

[Mechanical Drawing](#)

[Electrical Characteristics](#)

[Optical Characteristics](#)

[Timing Characteristics](#)

[Table of Commands](#)

[Built-in Font Tables](#)

[Driver/Controller Information](#)

[Reliability](#)

[Warranty and Conditions](#)

1 Revision History

Date	Changes
2018-12-13	First release

2 Main Features

Item	Specification	Unit
Number of Characters	16 characters x 2 lines	
Display Mode	FSTN Positive, Transflective	-
Resolution	5 x 8 dots with cursor	
Controller IC	ST7032 or equivalent	-
Interface	SPI Interface	-
Power Supply	3.0V	V
View Direction	6:00	-
Duty	1/16 duty, 1/5 bias	
Backlight	Edge White LED	-
Weight	5.5	g

3 Pin Description

Pin No.	Symbol	Function Description
1	RST	External reset Pin. Must be fixed to VDD low active
2	RS	Register Select Signal. RS=0:instruction; RS=1:data
3	CSB	Active LOW Chip Select signal
4	SCL	Serial Clock
5	SI	Serial Input data
6	VSS	Ground
7	VDD	Power supply for logic for LCD
8	VOUT	DC/DC voltage converter. Connect to 1Uf capacitor to VDD or VSS
9	C1+	Voltage booster circuit. Connect to 0.47uF-2.2uF cap to PIN10
10	C1-	Voltage booster circuit. Connect to 0.47uF-2.2uF cap to PIN9
A	LED+	Backlight Anode(3.0V)
K	LED-	Backlight Cathode(Ground)

Recommended LCD connector: LCD pins should be soldered directly onto thru-hole connection on PCB

Backlight connector: Backlight pins should be soldered directly onto thru-hole connection on PCB

4 Mechanical Drawing

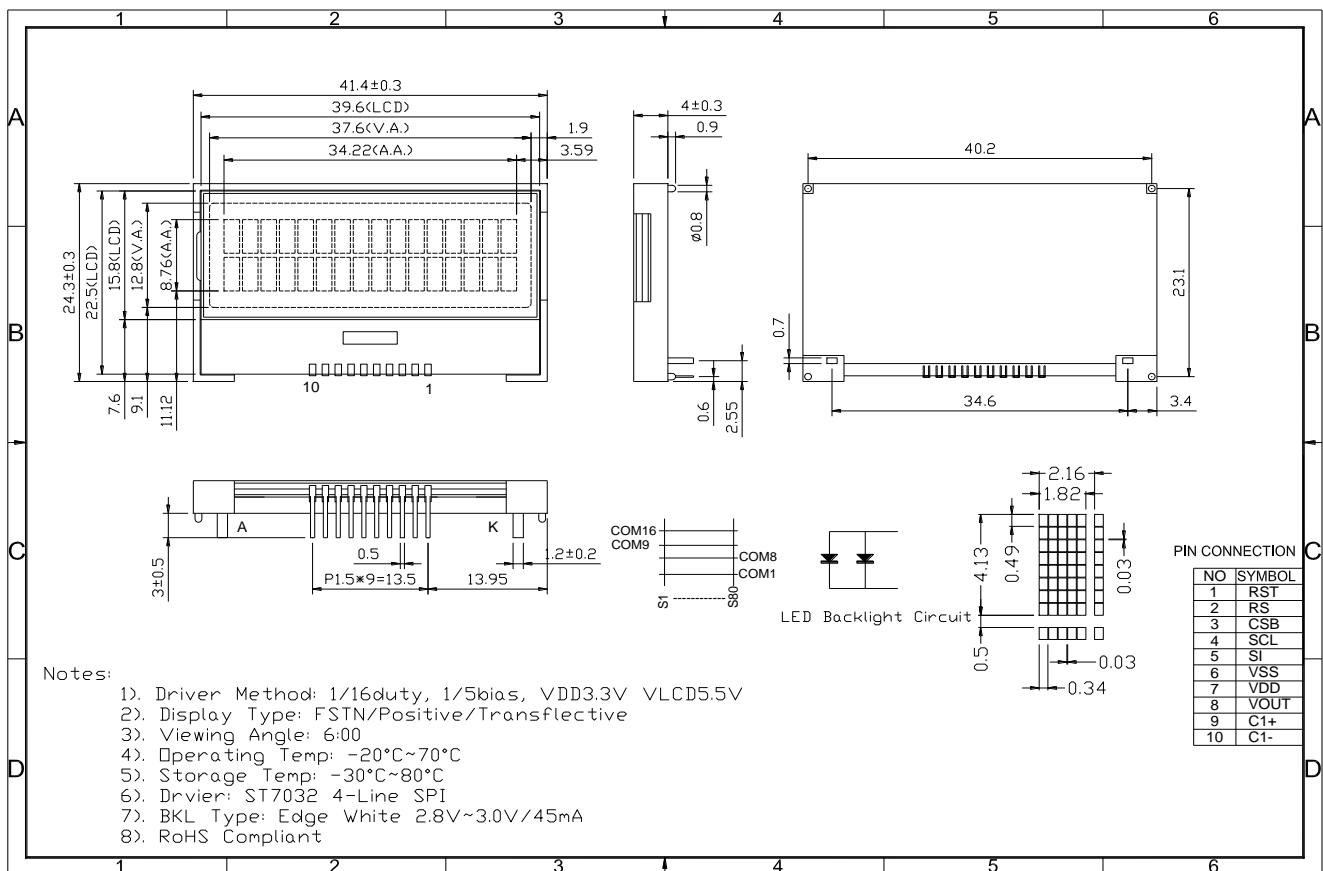

5 Electrical Characteristics

Item	Symbol	Condition	Min	Typ.	Max	Unit
Supply Voltage For Logic	VDD		2.7	3.0	3.3	V
Digital Operation Current	IDD	-	-	0.3	0.5	mA
Low Level Input Voltage	V _{IL}		0	-	0.6	V
High Level Input Voltage	V _{IH}		2.2	-	VDD	V
Low Level Output Voltage	V _{OL}		-		0.4	V
High Level Output Voltage	V _{OH}		2.4		-	V
Backlight Forward Voltage	V _{LED}		2.8		3.3	V
Backlight Forward Current	I _{LED}			30	40	mA
Operating Temperature	TOP	Absolute Max	-20		70	°C
Storage Temperature	TST	Absolute Max	-30		80	°C

6 Optical Characteristics

Item	Symbol	Min	Typ	Max	Unit
View Angles-Top -- Bottom	AV		60		°
View Angles-Left -- Right	AH		70		°
Response Time (25 °C)	Tr + Tf		350	550	us
Contrast Ratio	CR	3	5		
Luminance	L _v				cd/m ²

7 Timing Characteristics

SPI interface

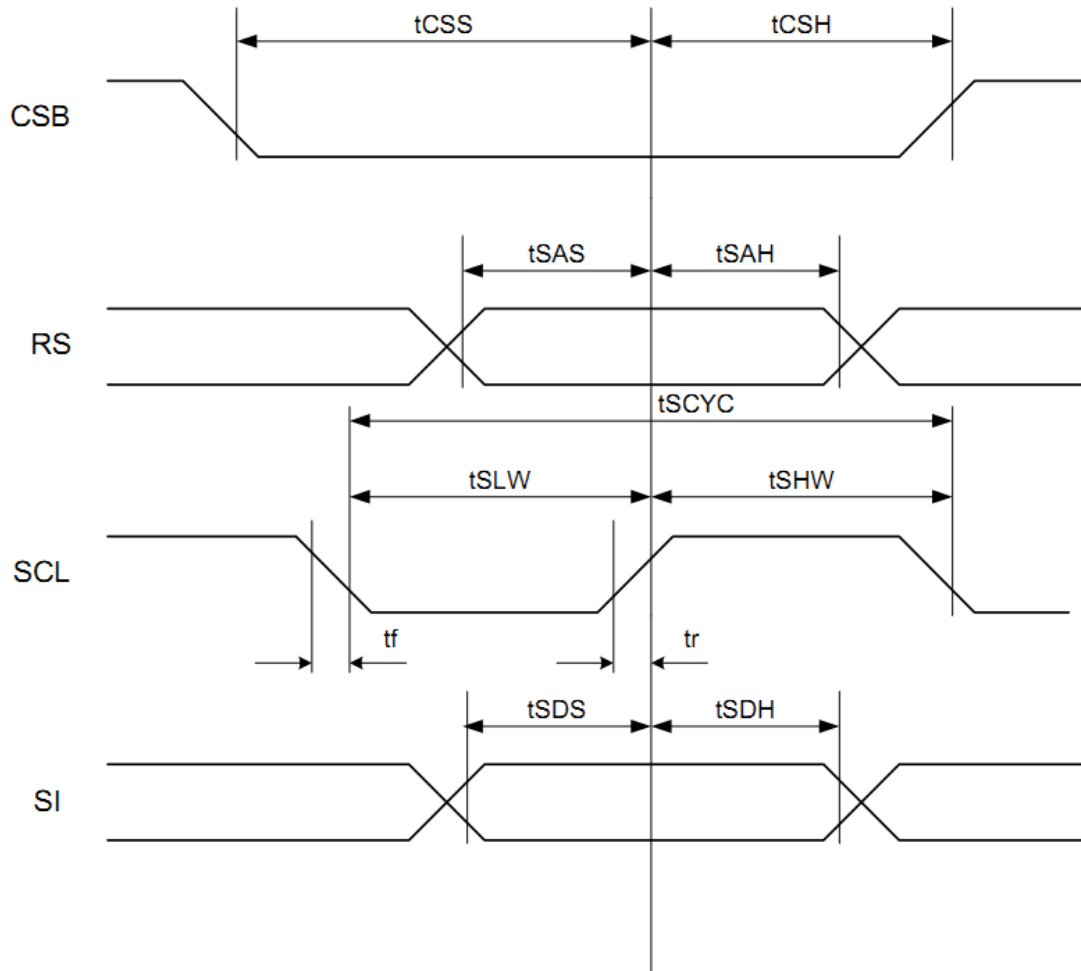

(Ta = 25°C)

Item	Signal	Symbol	Condition	VDD=2.7 to 4.5V Rating		VDD=4.5 to 5.5V Rating		Units
				Min.	Max.	Min.	Max.	
Serial Clock Period	SCL	tscyc	—	200	-	100	-	ns
SCL "H" pulse width		tshw	—	20	-	20	-	
SCL "L" pulse width		tslw	—	160	-	120	-	
SCL Rise/Fall time	SCL	tr,tf	—	-	20	-	20	ns
Address setup time	RS	tsas	—	10	-	10	-	ns
Address hold time		tsah	—	250	-	150	-	
Data setup time	SI	tsds	—	10	-	10	-	ns
Data hold time		tsdh	—	10	-	20	-	
CS-SCL time	CS	tcss	—	20	-	20	-	ns
		tcsH	—	350	-	200	-	

8 Table of Commands

Instruction table at “Normal mode”

Instruction	Instruction Code										Description	Instruction Execution Time		
	RS	R/W	DB7	DB6	DB5	DB4	DB3	DB2	DB1	DB0		OSC=380KHz	OSC=540kHz	OSC=700KHz
Clear Display	0	0	0	0	0	0	0	0	0	1	Write "20H" to DDRAM. and set DDRAM address to "00H" from AC	1.08 ms	0.76 ms	0.59 ms
Return Home	0	0	0	0	0	0	0	0	1	x	Set DDRAM address to "00H" from AC and return cursor to its original position if shifted. The contents of DDRAM are not changed.	1.08 ms	0.76 ms	0.59 ms
Entry Mode Set	0	0	0	0	0	0	0	1	I/D	S	Sets cursor move direction and specifies display shift. These operations are performed during data write and read.	26.3 us	18.5 us	14.3 us
Display ON/OFF	0	0	0	0	0	0	1	D	C	B	D=1:entire display on C=1:cursor on B=1:cursor position on	26.3 us	18.5 us	14.3 us
Cursor or Display Shift	0	0	0	0	0	1	S/C	R/L	x	x	S/C and R/L: Set cursor moving and display shift control bit, and the direction, without changing DDRAM data.	26.3 us	18.5 us	14.3 us
Function Set	0	0	0	0	1	DL	N	x	x	x	DL: interface data is 8/4 bits N: number of line is 2/1	26.3 us	18.5 us	14.3 us
Set CGRAM	0	0	0	1	AC5	AC4	AC3	AC2	AC1	AC0	Set CGRAM address in address counter	26.3 us	18.5 us	14.3 us
Set DDRAM address	0	0	1	AC6	AC5	AC4	AC3	AC2	AC1	AC0	Set DDRAM address in address counter	26.3 us	18.5 us	14.3 us
Read Busy flag and address	0	1	BF	AC6	AC5	AC4	AC3	AC2	AC1	AC0	Whether during internal operation or not can be known by reading BF. The contents of address counter can also be read.	0	0	0
Write data to RAM	1	0	D7	D6	D5	D4	D3	D2	D1	D0	Write data into internal RAM (DDRAM/CGRAM)	26.3 us	18.5 us	14.3 us
Read data from RAM	1	1	D7	D6	D5	D4	D3	D2	D1	D0	Read data from internal RAM (DDRAM/CGRAM)	26.3 us	18.5 us	14.3 us

Instruction table at “Extension mode”

Instruction	Instruction Code										Description	Instruction Execution Time		
	RS	R/W	DB7	DB6	DB5	DB4	DB3	DB2	DB1	DB0		OSC=380KHz	OSC=540kHz	OSC=700KHz
Clear Display	0	0	0	0	0	0	0	0	0	1	Write "20H" to DDRAM. and set DDRAM address to "00H" from AC	1.08 ms	0.76 ms	0.59 ms
Return Home	0	0	0	0	0	0	0	0	1	x	Set DDRAM address to "00H" from AC and return cursor to its original position if shifted. The contents of DDRAM are not changed.	1.08 ms	0.76 ms	0.59 ms
Entry Mode Set	0	0	0	0	0	0	0	1	I/D	S	Sets cursor move direction and specifies display shift. These operations are performed during data write and read.	26.3 us	18.5 us	14.3 us
Display ON/OFF	0	0	0	0	0	0	1	D	C	B	D=1:entire display on C=1:cursor on B=1:cursor position on	26.3 us	18.5 us	14.3 us
Function Set	0	0	0	0	1	DL	N	DH	*0	IS	DL: interface data is 8/4 bits N: number of line is 2/1 DH: double height font IS: instruction table select	26.3 us	18.5 us	14.3 us
Set DDRAM address	0	0	1	AC6	AC5	AC4	AC3	AC2	AC1	AC0	Set DDRAM address in address counter	26.3 us	18.5 us	14.3 us
Read Busy flag and address	0	1	BF	AC6	AC5	AC4	AC3	AC2	AC1	AC0	Whether during internal operation or not can be known by reading BF. The contents of address counter can also be read.	0	0	0
Write data to RAM	1	0	D7	D6	D5	D4	D3	D2	D1	D0	Write data into internal RAM (DDRAM/CGRAM/ICONRAM)	26.3 us	18.5 us	14.3 us
Read data from RAM	1	1	D7	D6	D5	D4	D3	D2	D1	D0	Read data from internal RAM (DDRAM/CGRAM/ICONRAM)	26.3 us	18.5 us	14.3 us

Note: this bit is for test command, and must always set to “0”

Instruction table 0 (IS=0)														
Cursor or Display Shift	0	0	0	0	0	1	S/C	R/L	x	x	S/C and R/L: Set cursor moving and display shift control bit, and the direction, without changing DDRAM data.	26.3 us	18.5 us	14.3 us
Set CGRAM	0	0	0	1	AC5	AC4	AC3	AC2	AC1	AC0	Set CGRAM address in address counter	26.3 us	18.5 us	14.3 us

Instruction table 1 (IS=1)														
Internal OSC frequency	0	0	0	0	0	1	BS	F2	F1	F0	BS=1:1/4 bias BS=0:1/5 bias F2-0: adjust internal OSC frequency for FR frequency.	26.3 us	18.5 us	14.3 us
Set ICON address	0	0	0	1	0	0	AC3	AC2	AC1	AC0	Set ICON address in address counter.	26.3 us	18.5 us	14.3 us
Power/ICON control/Contrast set	0	0	0	1	0	1	Ion	Bon	C5	C4	Ion: ICON display on/off Bon: set booster circuit on/off C5,C4: Contrast set for internal follower mode.	26.3 us	18.5 us	14.3 us
Follower control	0	0	0	1	1	0	Fon	Rab2	Rab1	Rab0	Fon: set follower circuit on/off Rab2-0: select follower amplified ratio.	26.3 us	18.5 us	14.3 us
Contrast set	0	0	0	1	1	1	C3	C2	C1	C0	Contrast set for internal follower mode.	26.3 us	18.5 us	14.3 us

9 Built-in Font Tables

b7-b4 b3-b0	0000	0001	0010	0011	0100	0101	0110	0111	1000	1001	1010	1011	1100	1101	1110	1111
0000																
0001																
0010																
0011																
0100																
0101																
0110																
0111																
1000																
1001																
1010																
1011																
1100																
1101																
1110																
1111																

10 Driver/Controller Information

Built-in ST7032 Controller

<https://drive.google.com/file/d/0BxCL-uXywP6weERkRVZ4NkF6SzQ/view?usp=sharing>

11 Reliability

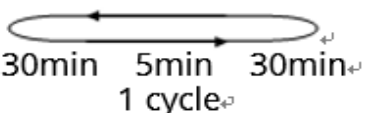
Test Item	Content of Test	Test Condition	Note
High Temperature Storage	Endurance test applying the high storage temperature for a long time.	80°C 200hrs	2
Low Temperature Storage	Endurance test applying the high storage temperature for a long time.	-30°C 200hrs	1,2
High Temperature Operation	Endurance test applying the electric stress (Voltage & Current) and the thermal stress to the element for a long time.	70°C 200hrs	-
Low Temperature Operation	Endurance test applying the electric stress under low temperature for a long time.	-20 °C 200hrs	1
High Temperature/ Humidity Operation	The module should be allowed to stand at 60°C,90%RH max, for 96hrs under no-load condition excluding the polarizer. Then taking it out and drying it at normal temperature.	60°C,90%RH 96hrs	1,2
Thermal Shock Resistance	The sample should be allowed stand the following 10 cycles of operation 	-20°C/70°C 10 cycles	-
Vibration Test	Endurance test applying the vibration during transportation and using	Total fixed amplitude: 15mm; Vibration: 10~55Hz; One cycle 60 seconds to 3 directions of X, Y, Z, for each 16 minutes.	3
Static Electricity Test	Endurance test apply the electric stress to the terminal.	VS=800V, RS=1.5kΩ, CS=100pF, 1 time.	-

Note1: No dew condensation to be observed.

Note2: The function test shall be conducted after 4 hours storage at the normal. Temperature and humidity after remove from the rest chamber.

Note3: Test performed on product itself, not inside a container.

12 Warranty and Conditions

<http://www.displaymodule.com/pages/faq>