

**DM-COG2002-713**  
**2002 COG CHARACTER LCD WITH I2C**  
**MPU INTERFACE**

## Contents

[Revision History](#)

[Main Features](#)

[Pin Description](#)

[Mechanical Drawing](#)

[Electrical Characteristics](#)

[Optical Characteristics](#)

[Table of Commands](#)

[Timing Characteristics](#)

[Initializing by Instruction](#)

[Example Initialization Program](#)

[Driver/Controller Information](#)

[Reliability](#)

[Warranty and Conditions](#)

## 1 Revision History

Date	Changes
2015-03-13	First release

## 2 Main Features

Item	Specification	Unit
Number of Characters	20 characters x 2 lines	
LCD Type	FSTN Positive	
Driver Mode	Transflective	-
Controller IC	ST7036I	-
Interface	I2C MPU Interface	-
Power Supply	3.3	V
View Direction	6:00	-
Duty	1/16 duty, 1/5 bias	
Backlight	White LED	-
Weight	15.1	g

### 3 Pin Description

Pin No.	Symbol	Function Description
1	VOUT	DC/DC voltage converter. Connect a capacitor between this terminal and VIN when the built-in booster is used.
2	CAP1N	For voltage booster circuit(VDD-VSS) External capacitor about 0.1u~4.7uf
3	CAP1P	
4	VDD	Power Supply (3.0/5.0V)
5	VSS	GND
6	SDA	In I2C interface DB7 (SDA) is input data. SDA and SCL must connect to I2C bus (I2C bus is to connect a resistor between SDA/SCL and the power of I2C bus )
7	SCL	In I2C interface DB6 (SCL) is clock input. SDA and SCL must connect to I2C bus (I2C bus is to connect a resistor between SDA/SCL and the power of I2C bus ).
8	RST	RESET

VDD=3.0V

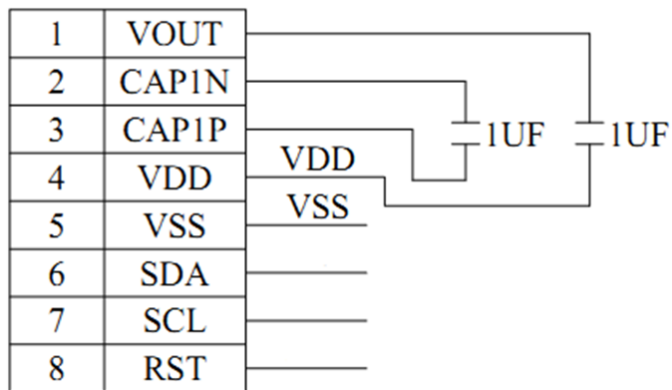

VDD=5.0V

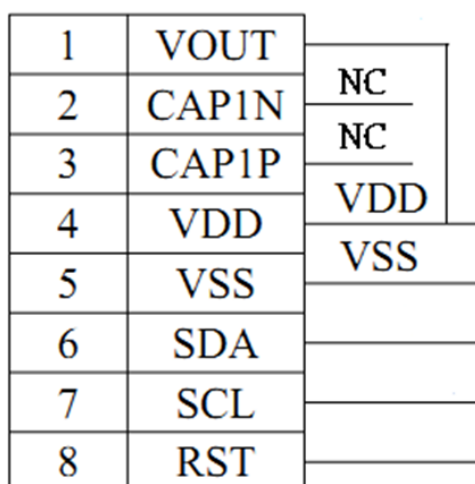

## 4 Mechanical Drawing

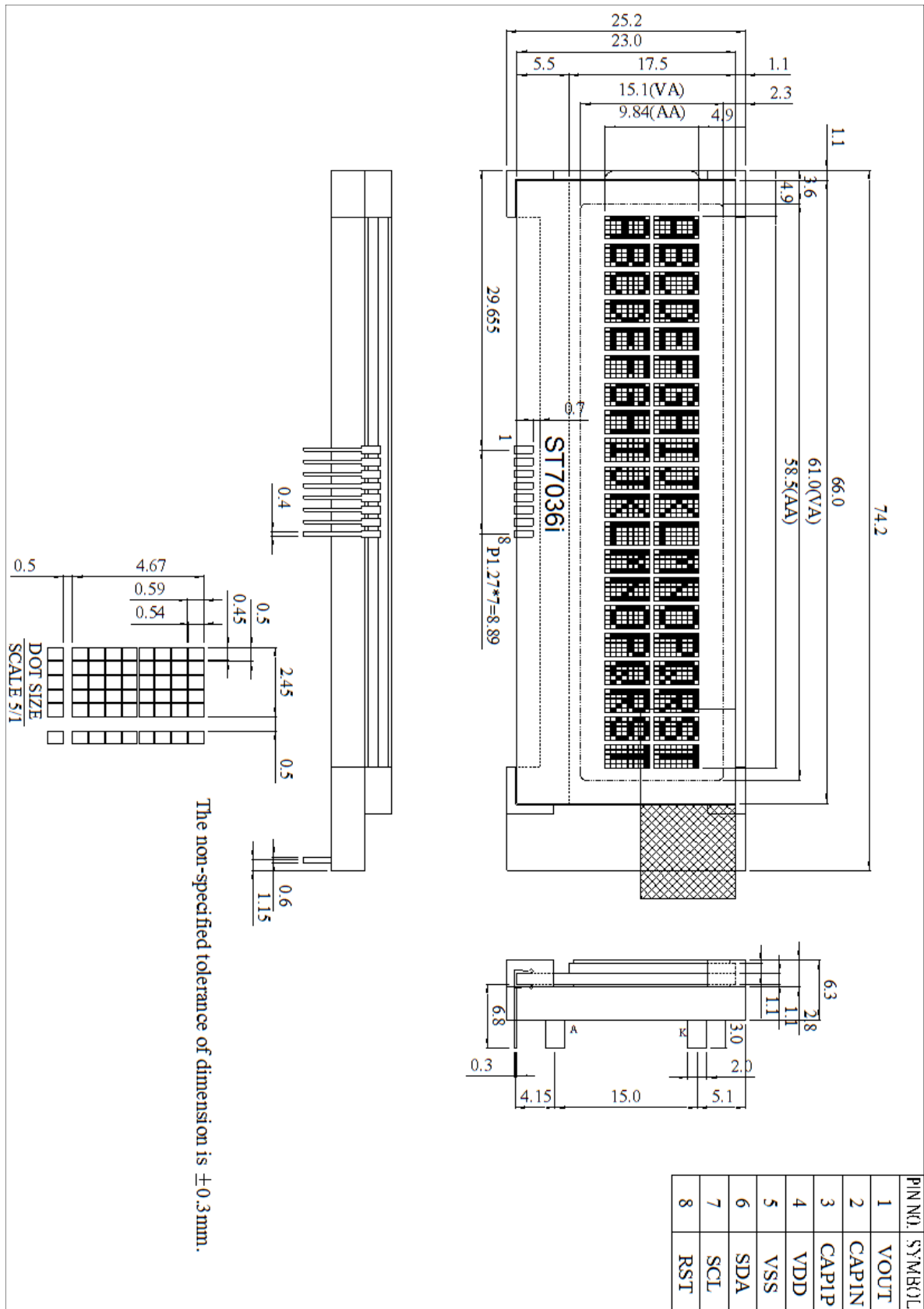

## 5 Electrical Characteristics

Item	Symbol	Condition	Min	Typ.	Max	Unit
Supply Voltage For Logic	VDD		3	3.3	5	V
Digital Operation Current	IDD	-	-	0.2		mA
Low Level Input Voltage	V <sub>IL</sub>		-	-	0.2VDD	V
High Level Input Voltage	V <sub>IH</sub>		0.7VDD	-	VDD	V
Low Level Output Voltage	V <sub>OL</sub>		-		0.8	V
High Level Output Voltage	V <sub>OH</sub>		0.7VDD		-	V
Backlight Forward Voltage	V <sub>LED</sub>		3.4	3.5	3.6	V
Backlight Forward Current	I <sub>LED</sub>			32	40	mA
Operating Temperature	TOP	Absolute Max	-20		70	°C
Storage Temperature	TST	Absolute Max	-30		80	°C

## 6 Optical Characteristics

Item	Symbol	Min	Typ	Max	Unit	Note
View Angles-Top	AH	0		30	°	
View Angles-Bottom	AH	0		60	°	
View Angles-Right	AV	0		45	°	
View Angles-Left	AV	0		45	°	
Response Time (25°C)	Tr + Tf		450	650	us	
Contrast Ratio	CR		5			

## 7 Table of Commands

Instruction	Instruction Code										Description	Instruction Execution Time		
	RS	R/W	DB7	DB6	DB5	DB4	DB3	DB2	DB1	DB0		OSC=380kHz	OSC=540kHz	OSC=700kHz
Clear Display	0	0	0	0	0	0	0	0	0	1	Write "20H" to DDRAM. and set DDRAM address to "00H" from AC	1.08 ms	0.76 ms	0.59 ms
Return Home	0	0	0	0	0	0	0	0	1	X	Set DDRAM address to "00H" from AC and return cursor to its original position if shifted. The contents of DDRAM are not changed.	1.08 ms	0.76 ms	0.59 ms
Entry Mode Set	0	0	0	0	0	0	0	1	I/D	S	Sets cursor move direction and specifies display shift. These operations are performed during data write and read.	26.3 μs	18.5 μs	14.3 μs
Display ON/OFF	0	0	0	0	0	0	1	D	C	B	D=1:entire display on C=1:cursor on B=1:cursor position on	26.3 μs	18.5 μs	14.3 μs
Cursor or Display Shift	0	0	0	0	0	1	S/C	R/L	X	X	S/C and R/L: Set cursor moving and display shift control bit, and the direction, without changing DDRAM data.	26.3 μs	18.5 μs	14.3 μs
Function Set	0	0	0	0	1	DL	N	X	X	X	DL: interface data is 8/4 bits N: number of line is 2/1	26.3 μs	18.5 μs	14.3 μs
Set CGRAM	0	0	0	1	AC5	AC4	AC3	AC2	AC1	AC0	Set CGRAM address in address counter	26.3 μs	18.5 μs	14.3 μs
Set DDRAM Address	0	0	1	AC6	AC5	AC4	AC3	AC2	AC1	AC0	Set DDRAM address in address counter	26.3 μs	18.5 μs	14.3 μs
Read Busy Flag and Address	0	1	BF	AC6	AC5	AC4	AC3	AC2	AC1	AC0	Whether during internal operation or not can be known by reading BF. The contents of address counter can also be read.	0	0	0
Write Data to RAM	1	0	D7	D6	D5	D4	D3	D2	D1	D0	Write data into internal RAM (DDRAM/CGRAM)	26.3 μs	18.5 μs	14.3 μs
Read Data from RAM	1	1	D7	D6	D5	D4	D3	D2	D1	D0	Read data from internal RAM (DDRAM/CGRAM)	26.3 μs	18.5 μs	14.3 μs

Instruction	Instruction Code										Description	Instruction Execution Time		
	RS	R/W	DB7	DB6	DB5	DB4	DB3	DB2	DB1	DB0		OSC=380kHz	OSC=540kHz	OSC=700kHz
Clear Display	0	0	0	0	0	0	0	0	0	1	Write "20H" to DDRAM, and set DDRAM address to "00H" from AC	1.08 ms	0.76 ms	0.59 ms
Return Home	0	0	0	0	0	0	0	0	1	x	Set DDRAM address to "00H" from AC and return cursor to its original position if shifted. The contents of DDRAM are not changed.	1.08 ms	0.76 ms	0.59 ms
Entry Mode Set	0	0	0	0	0	0	0	1	I/D	S	Sets cursor move direction and specifies display shift. These operations are performed during data write and read.	26.3 μs	18.5 μs	14.3 μs
Display ON/OFF	0	0	0	0	0	0	1	D	C	B	D=1:entire display on C=1:cursor on B=1:cursor position on	26.3 μs	18.5 μs	14.3 μs
Function Set	0	0	0	0	1	DL	N	DH	IS2	IS1	DL: interface data is 8/4 bits N: number of line is 2/1 DH: double height font IS[2:1]: instruction table select	26.3 μs	18.5 μs	14.3 μs
Set DDRAM Address	0	0	1	AC6	AC5	AC4	AC3	AC2	AC1	AC0	Set DDRAM address in address counter	26.3 μs	18.5 μs	14.3 μs
Read Busy Flag and Address	0	1	BF	AC6	AC5	AC4	AC3	AC2	AC1	AC0	Whether during internal operation or not can be known by reading BF. The contents of address counter can also be read.	0	0	0
Write Data to RAM	1	0	D7	D6	D5	D4	D3	D2	D1	D0	Write data into internal RAM (DDRAM/CGRAM/ICONRAM)	26.3 μs	18.5 μs	14.3 μs
Read Data from RAM	1	1	D7	D6	D5	D4	D3	D2	D1	D0	Read data from internal RAM (DDRAM/CGRAM/ICONRAM)	26.3 μs	18.5 μs	14.3 μs



Instruction table 0(IS[2:1]=[0,0])														
Cursor or Display Shift	0	0	0	0	0	1	S/C	R/L	X	X	S/C and R/L: Set cursor moving and display shift control bit, and the direction, without changing DDRAM data.	26.3 $\mu$ s	18.5 $\mu$ s	14.3 $\mu$ s
Set CGRAM	0	0	0	1	AC5	AC4	AC3	AC2	AC1	AC0	Set CGRAM address in address counter	26.3 $\mu$ s	18.5 $\mu$ s	14.3 $\mu$ s

Instruction table 1(IS[2:1]=[0,1])														
Bias Set	0	0	0	0	0	1	BS	1	0	FX	BS=1:1/4 bias BS=0:1/5 bias FX: fixed on high in 3-line application and fixed on low in other applications.	26.3 $\mu$ s	18.5 $\mu$ s	14.3 $\mu$ s
Set ICON Address	0	0	0	1	0	0	AC3	AC2	AC1	AC0	Set ICON address in address counter.	26.3 $\mu$ s	18.5 $\mu$ s	14.3 $\mu$ s
Power/ICON Control/ Contrast Set	0	0	0	1	0	1	Ion	Bon	C5	C4	Ion: ICON display on/off Bon: set booster circuit on/off C5,C4: Contrast set for internal follower mode.	26.3 $\mu$ s	18.5 $\mu$ s	14.3 $\mu$ s
Follower Control	0	0	0	1	1	0	Fon	Rab 2	Rab 1	Rab 0	Fon: set follower circuit on/off Rab2-0: select follower amplified ratio.	26.3 $\mu$ s	18.5 $\mu$ s	14.3 $\mu$ s
Contrast Set	0	0	0	1	1	1	C3	C2	C1	C0	Contrast set for internal follower mode.	26.3 $\mu$ s	18.5 $\mu$ s	14.3 $\mu$ s

Instruction table 2(IS[2:1]=[1,0])														
Double Height Position Select	0	0	0	0	0	1	UD	X	x	x	UD: Double height position select	26.3 $\mu$ s	18.5 $\mu$ s	14.3 $\mu$ s
Reserved	0	0	0	1	X	X	X	X	X	X	Do not use (reserved for test)	26.3 $\mu$ s	18.5 $\mu$ s	14.3 $\mu$ s

## 8 Timing Characteristics

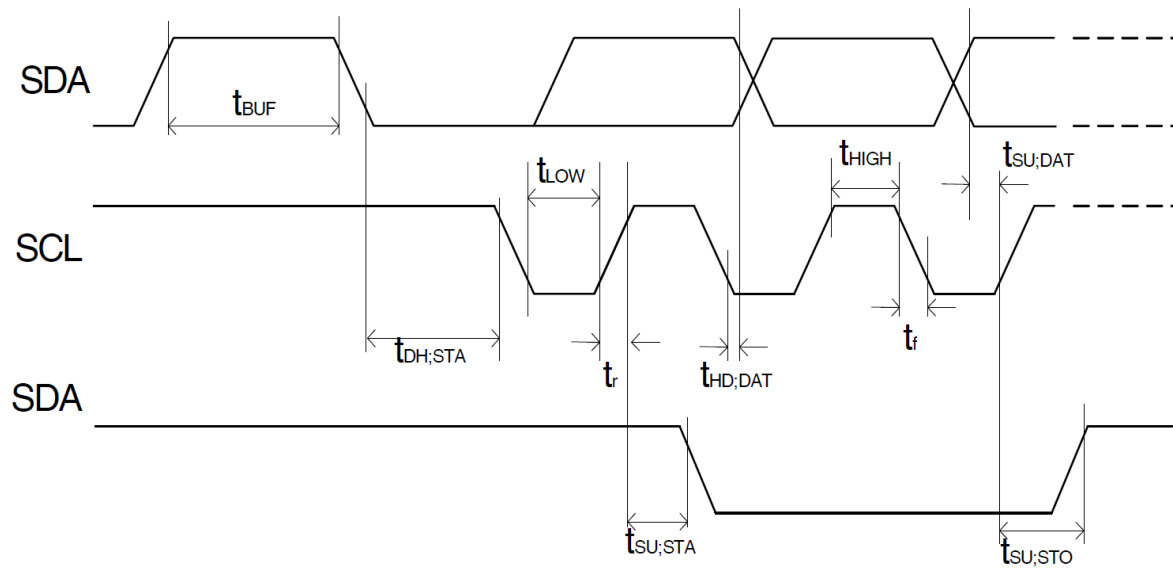

Symbol	Parameter	Min.	Typ.	Max.	Unit
$f_{SCLK}$	SCL clock frequency	DC	-	300	KHz
$t_{LOW}$	SCL clock low period	12.5	-	-	us
$t_{HIGH}$	SCL clock high period	0.6	-	-	ns
$t_{SU:DAT}$	Data set-up time	1800	-	-	us
$t_{HD:DAT}$	Data hold time	0	-	-	ns
$t_r$	SCL, SDA rise time	$20+0.1C_b$	-	300	ns
$t_f$	SCL, SDA fall time	$20+0.1C_b$	-	300	ns
$C_b$	Capacitive load represent by each bus line	-	-	400	pf
$t_{SU:STA}$	Setup time for a repeated START condition	0.6	-	-	us
$t_{HD:STA}$	Start condition hold time	1.8	-	-	us
$t_{SU:STO}$	Setup time for STOP condition	0.6	-	-	us
$t_{BUF}$	Bus free time between a Stop and START condition	1.3	-	-	us

## 9 Initializing by Instruction

### 8-bit Interface

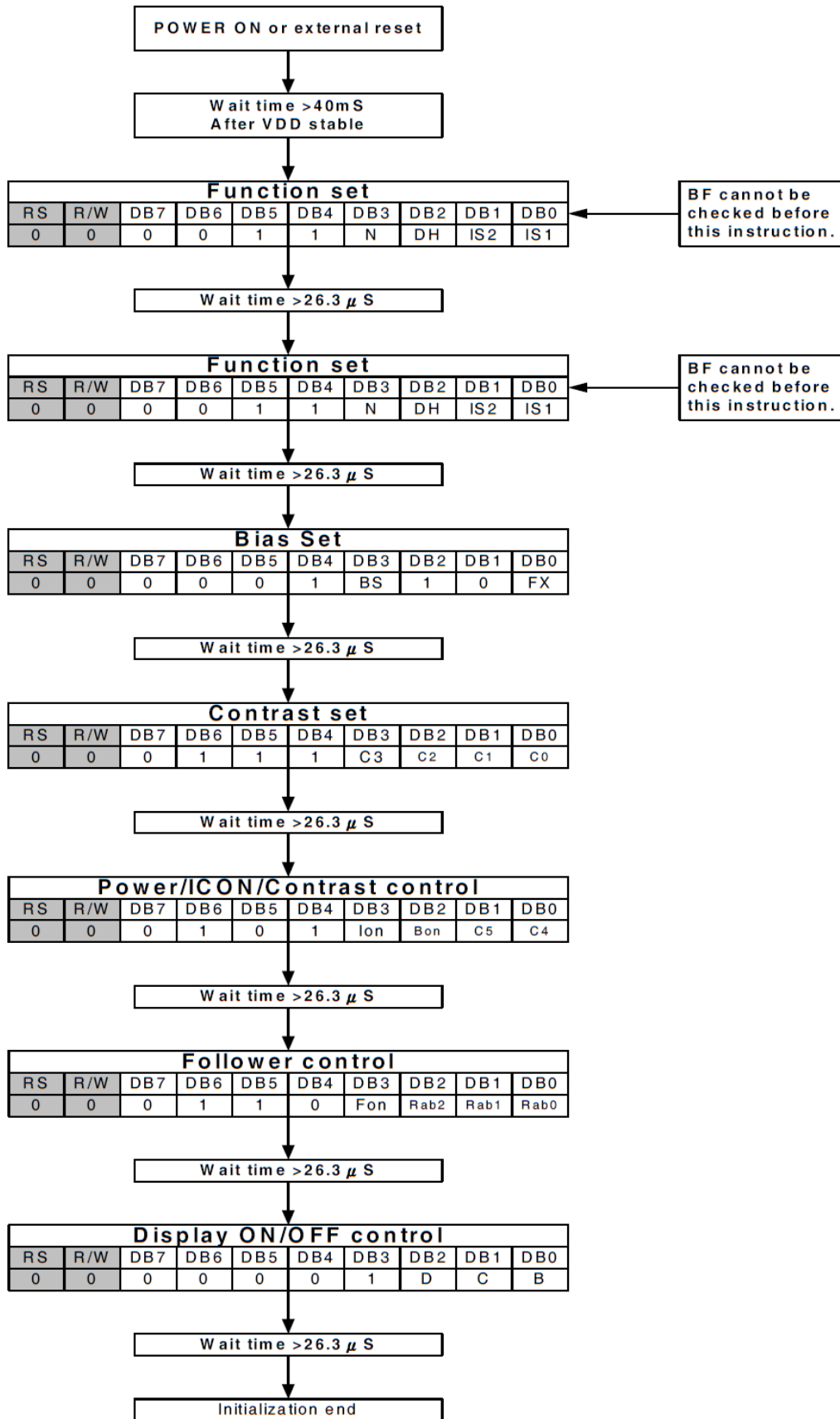

## 4-bit Interface

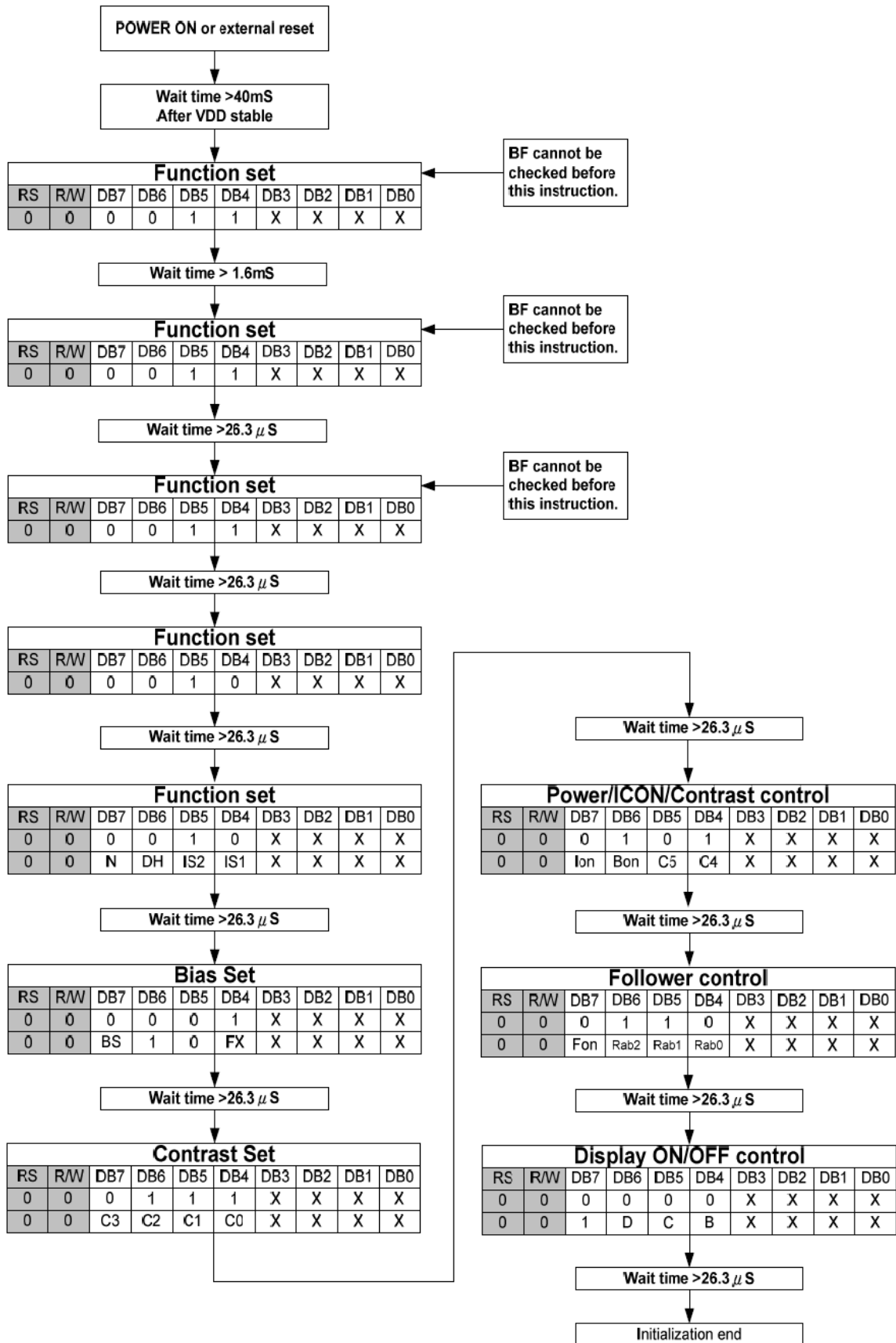

## Serial or I2C Interface

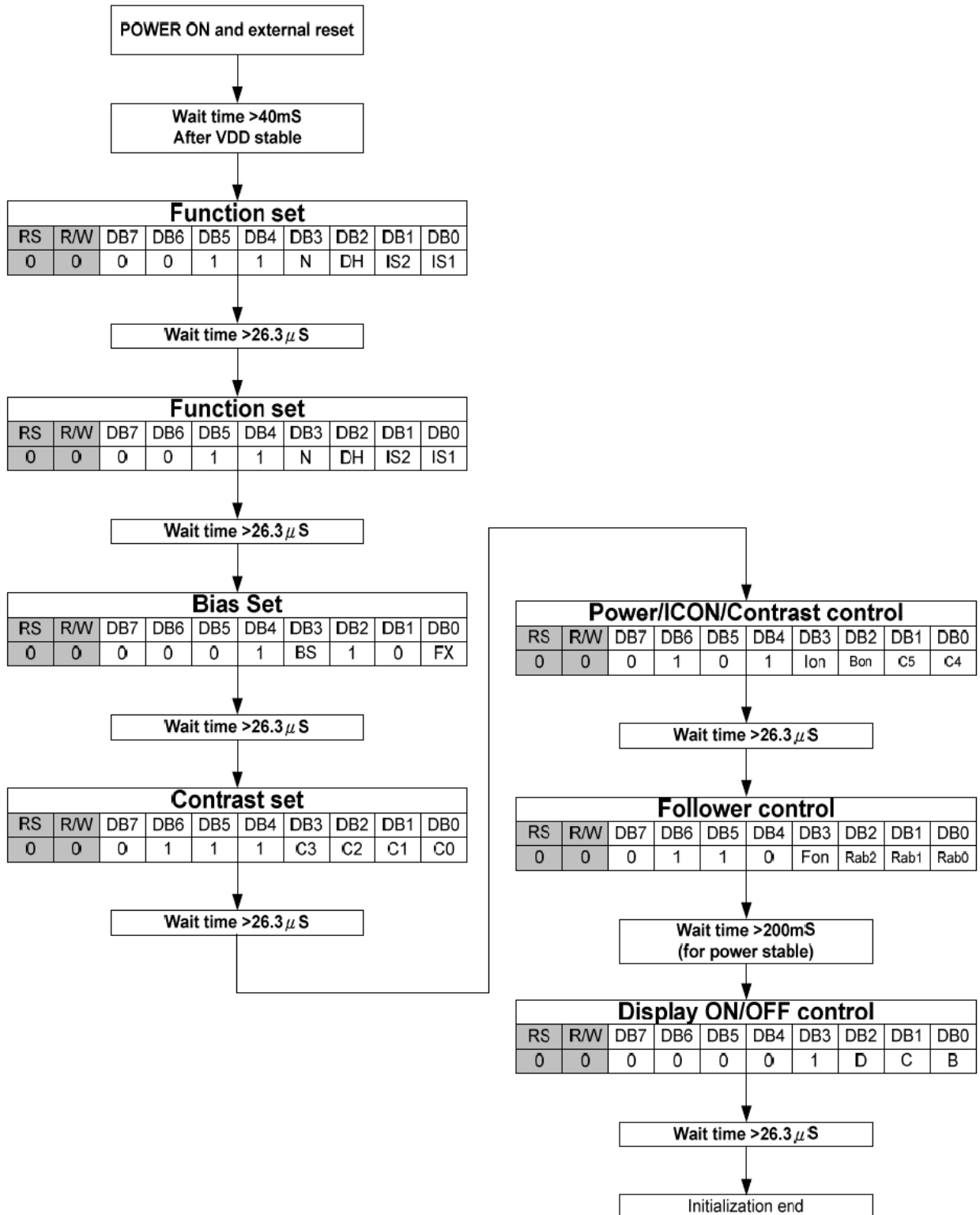

## 10 Example Initialization Program

### INITIALIZE: (3V)

```
MOV   I2C_CONTROL,#00H   ;WRITE COMMAND
MOV   I2C_DATA,#38H     ;Function Set
LCALL WRITE_CODE
MOV   I2C_CONTROL,#00H   ;WRITE COMMAND
MOV   I2C_DATA,#39H     ;Function Set
LCALL WRITE_CODE
MOV   I2C_DATA,#14H     ;Internal OSC frequency
LCALL WRITE_CODE
MOV   I2C_DATA,#74H     ;Contrast set
LCALL WRITE_CODE
MOV   I2C_DATA,#54H     ;Power/ICON control/Contrast set
LCALL WRITE_CODE
MOV   I2C_DATA,#6FH     ;Follower control
LCALL WRITE_CODE
MOV   I2C_DATA,#0CH     ;Display ON/OFF
LCALL WRITE_CODE
MOV   I2C_DATA,#01H     ;Clear Display
LCALL WRITE_CODE
```

### INITIALIZE: (5V)

```
MOV   I2C_CONTROL,#00H   ;WRITE COMMAND
MOV   I2C_DATA,#38H     ;Function Set
LCALL WRITE_CODE
MOV   I2C_CONTROL,#00H   ;WRITE COMMAND
MOV   I2C_DATA,#39H     ;Function Set
LCALL WRITE_CODE
MOV   I2C_DATA,#14H     ;Internal OSC frequency
LCALL WRITE_CODE
MOV   I2C_DATA,#79H     ;Contrast set
LCALL WRITE_CODE
MOV   I2C_DATA,#50H     ;Power/ICON control/Contrast set
LCALL WRITE_CODE
MOV   I2C_DATA,#6CH     ;Follower control
LCALL WRITE_CODE
MOV   I2C_DATA,#0CH     ;Display ON/OFF
LCALL WRITE_CODE
MOV   I2C_DATA,#01H     ;Clear Display
LCALL WRITE_CODE
```

## 11 Driver/Controller Information

Built-in ST7036I Controller

[https://drive.google.com/file/d/0B\\_HGldxxTS9ITjRHcEt1M1RrbWc/view?usp=sharing](https://drive.google.com/file/d/0B_HGldxxTS9ITjRHcEt1M1RrbWc/view?usp=sharing)

## 12 Reliability

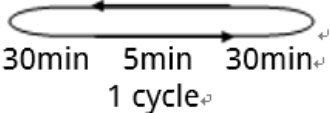
Test Item	Content of Test	Test Condition	Note
High Temperature Storage	Endurance test applying the high storage temperature for a long time.	80°C 200hrs	2
Low Temperature Storage	Endurance test applying the high storage temperature for a long time.	-30°C 200hrs	1,2
High Temperature Operation	Endurance test applying the electric stress (Voltage & Current) and the thermal stress to the element for a long time.	70°C 200hrs	-
Low Temperature Operation	Endurance test applying the electric stress under low temperature for a long time.	-20 °C 200hrs	1
High Temperature/ Humidity Operation	The module should be allowed to stand at 60°C,90%RH max, for 96hrs under no-load condition excluding the polarizer. Then taking it out and drying it at normal temperature.	60°C,90%RH 96hrs	1,2
Thermal Shock Resistance	The sample should be allowed stand the following 10 cycles of operation 	-20°C/70°C 10 cycles	-
Vibration Test	Endurance test applying the vibration during transportation and using	Total fixed amplitude: 15mm; Vibration: 10~55Hz; One cycle 60 seconds to 3 directions of X, Y, Z, for each 16 minutes.	3
Static Electricity Test	Endurance test apply the electric stress to the terminal.	VS=800V, RS=1.5kΩ, CS=100pF, 1 time.	-

Note1: No dew condensation to be observed.

Note2: The function test shall be conducted after 4 hours storage at the normal. Temperature and humidity after remove from the rest chamber.

Note3: The packing have to including into the vibration testing.

## 13 Warranty and Conditions

<http://www.displaymodule.com/pages/faq>