

AR Optical Waveguide Module

ARM-105

Product display

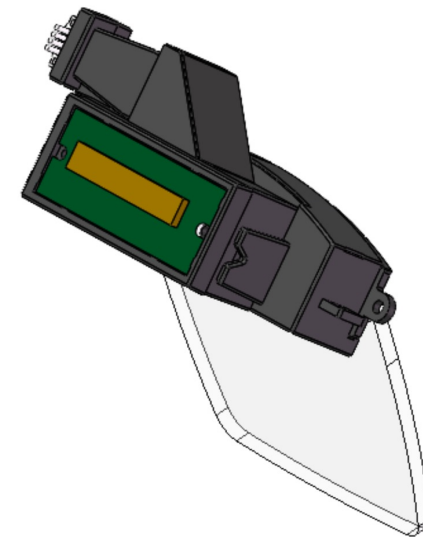
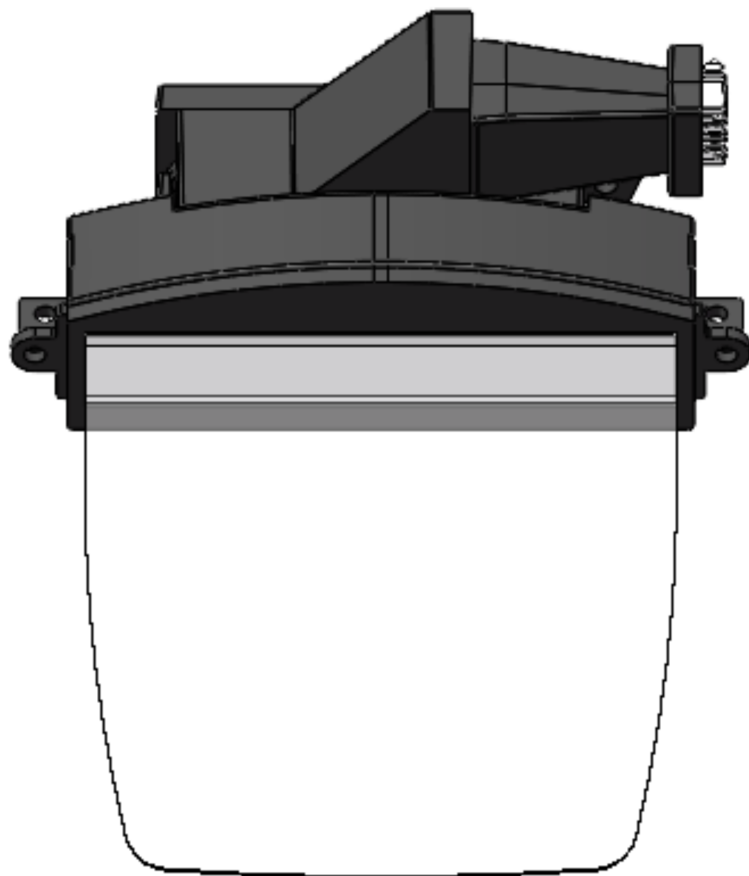

ARM-102 Optical Parameters Table

Parameter	Specification
Field of View	40°= 35.2°(H)×20.2°(V)
Focal Length	21.5 mm
F/#	0.51
Image Source	0.55" LCOS 1920 x 1080 RGB 6.4um/pixel
Eye Movement Distortion	< 10' @max field
Brightness	1000 nits
Contrast Ratio	200:1 (FOFO)
Exit Pupil Distance	22 mm
Eye Movement Range	12mm Height x 10 mm Width
Transmittance	> 85%

Optical module development instructions

- LCOS model: Raontech RDP551F
- LCOS driver chip: RDC200A (One chip can drive two screens)
- Display input signal: 4-lane MIPI or LVDS
- LCOS connector model: I-PEX 20586 (0.5mm Pitch FPC Connector)
- LED backlight connector model: SM04B-SURS-TF_0.8MM

Reference materials provided by the development kit

- 1.LCOS RDP551F datasheet
- 2.Datasheet for LCOS driver chip RDC200A
- 3.Datasheet for LED backlight driver IC (recommended ISL97901 or LM3435)
- 4.RDC200A System Design Guide
- 5.PCB Layout Guide
- 6.Reference schematic diagram
- 7.AW82 optical engine 3D drawings
- 8.Driver program for RDC200A

Driver workflow

1. Power up various power supplies on schedule (I2C).
2. Reset the RDC200A chip.
3. Start inputting MIPI or LVDS signals.
4. Enable the LED driver IC.
5. Initialize and illuminate the LED driver IC with the desired configuration.

Note: The program for RDC200A is stored in Flash memory and automatically loads and runs after reset. Generally, no additional configuration is required.

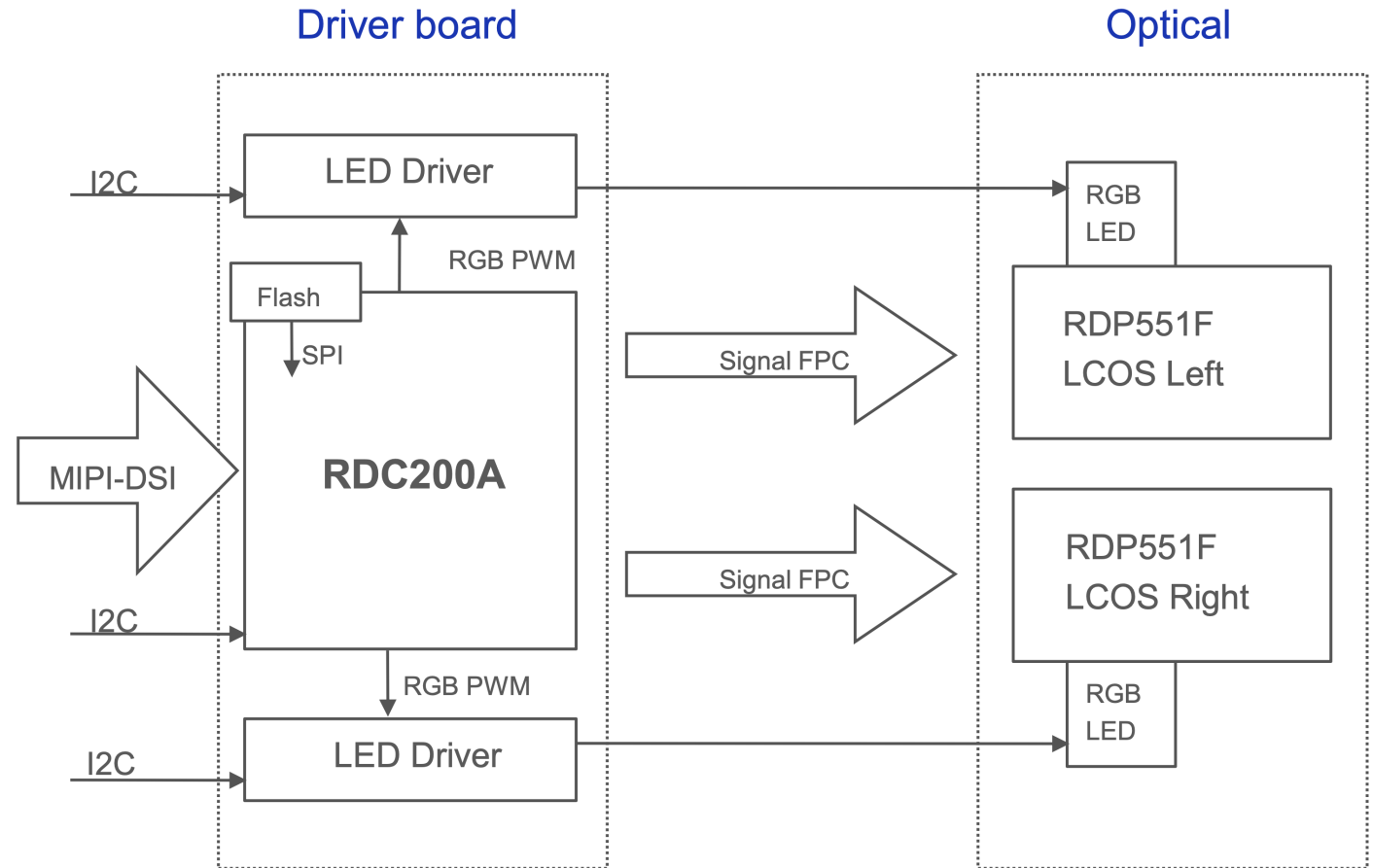

Stereo Vision Driver Architecture Diagram

LED Specifications

Parameter	Maximum Value	Unit
Power Dissipation	R:560	mW
	G:680	
	B:680	
Pulse Current (1/10 Duty,0.1ms pulse)	R:300	mA
	G:300	
	B:300	
Forward Current	R:150	mA
	G:150	
	B:150	
Reverse Voltage	5	V
Junction Temperature	100°C	
Operating Temperature	-40°C to +85°C	
Storage Temperature	-40°C to +90°C	
Soldering Temperature	255°C for 10 Seconds	
ESD (Classification acc AEC Q101)	ESDHEM	R:2000V
		G:1000V
		B:1000V
	ESD	200V

LED Backlight Connector Schematic Diagram

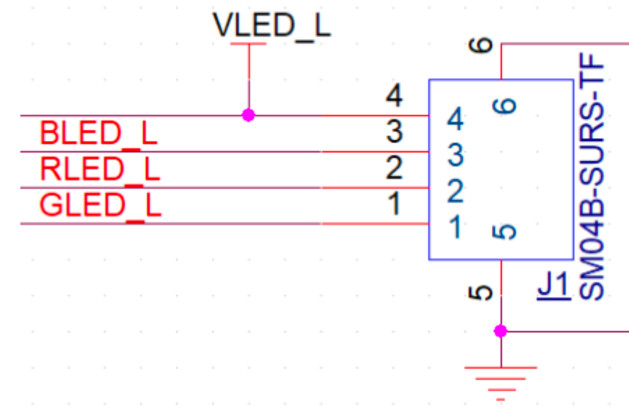

LED Backlight Connector PCB

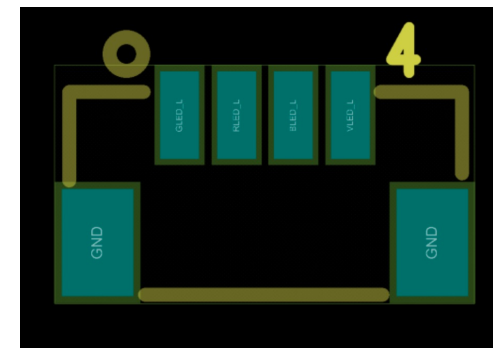

LED Specifications

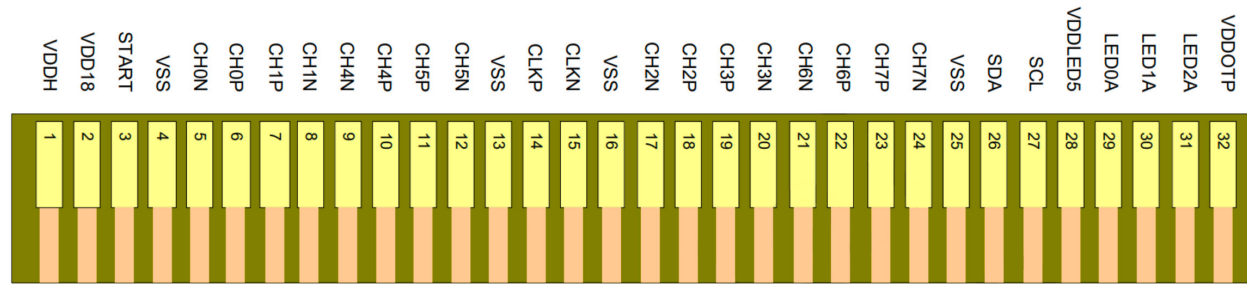

FPC

[Top View]

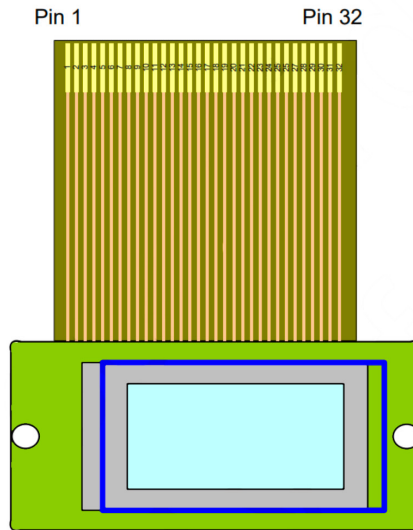

[Bottom View]

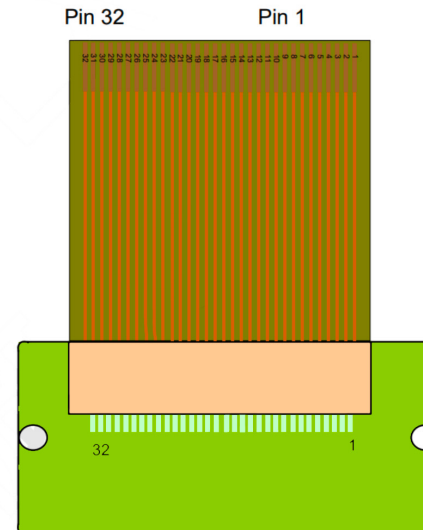
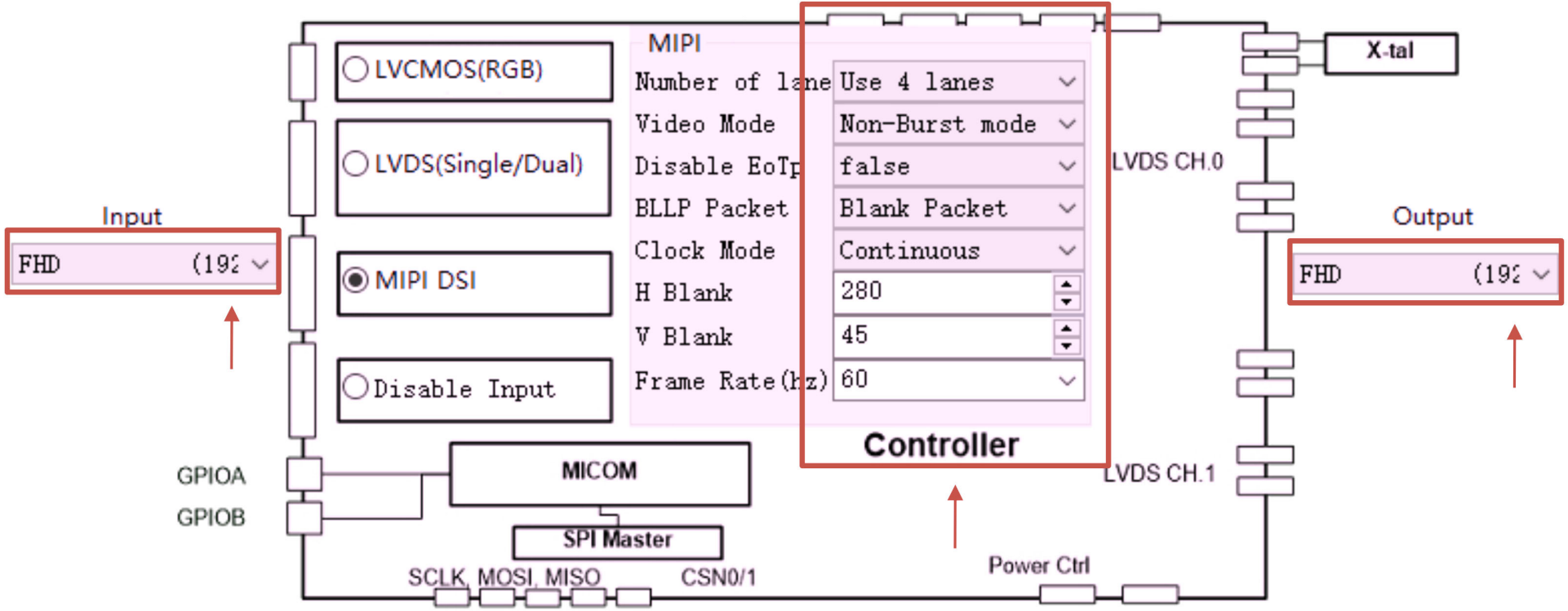

Figure 4. FPC Pin Configuration

Controller InOut Select



MIPI input parameter settings

LED Backlight Brightness Initialization and Adjustment

Taking the LM3435 driver IC as an example

(The parameters are communicated through the I2C interface, the 8-bit device address of the chip is 0x50 or 0x52)

According to the following memory address, write corresponding parameters to LM 3435

```
0x00~0x03 =  
{  
    0x00, 0x15, 0x15, 0x15  
}
```

The register addresses for controlling the current of the RGB backlight are 0x01, 0x02, and 0x03 (0x00 is a register composed of the two least significant bits of R/G/B and is generally not used). Changing the values of these three registers will immediately adjust the brightness of the corresponding LEDs.

In most cases, the values of these three registers are the same, resulting in a pure white backlight. However, due to variations in the brightness curves of the three types of LED chips (R, G, and B), there may be inconsistent white balance at certain brightness levels, requiring slight adjustments to the corresponding registers.

Based on the reference schematic provided by Lingxi, the register 0x01 corresponds to the blue light, 0x02 corresponds to the red light, and 0x03 corresponds to the green light.

Optical Mechanism

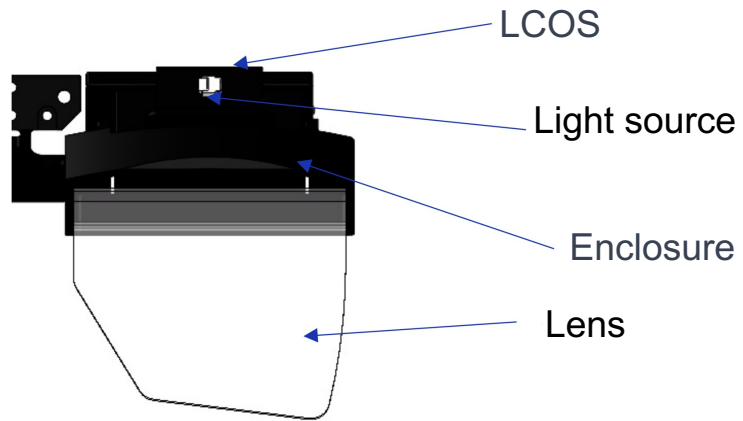

Optical Display Area

(Display center, designed to be directly aligned with the human eye (refer to the diagram for details))

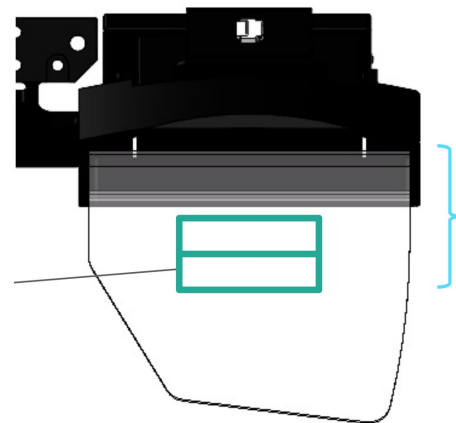

MIPI Video Timing Table

1. The light guide LOE (Light Outcoupling Efficiency) structure of the left and right optical modules is symmetrically designed.
2. The recommended distance between the eyeball and LOE is not greater than 22mm.
3. The recommended design value for the distance between the display centers of the left and right eyes is 64mm (corresponding to the interpupillary distance of the human eye).

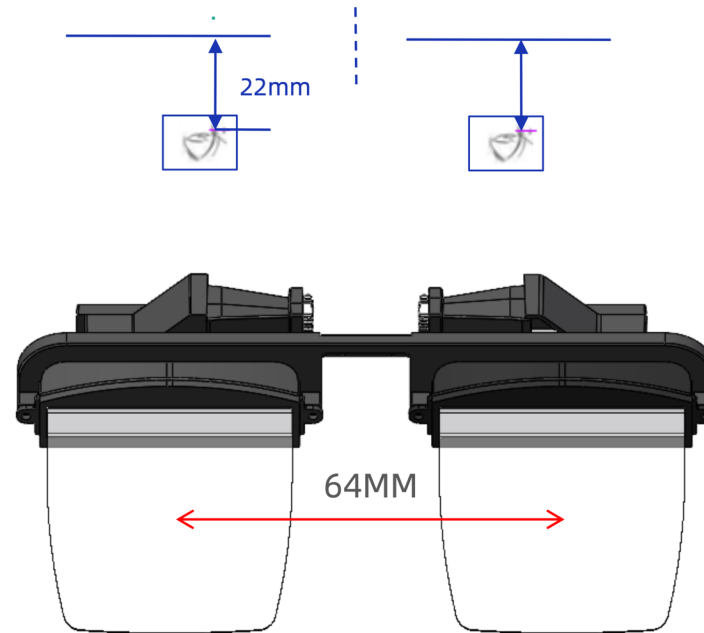

Structural Reference

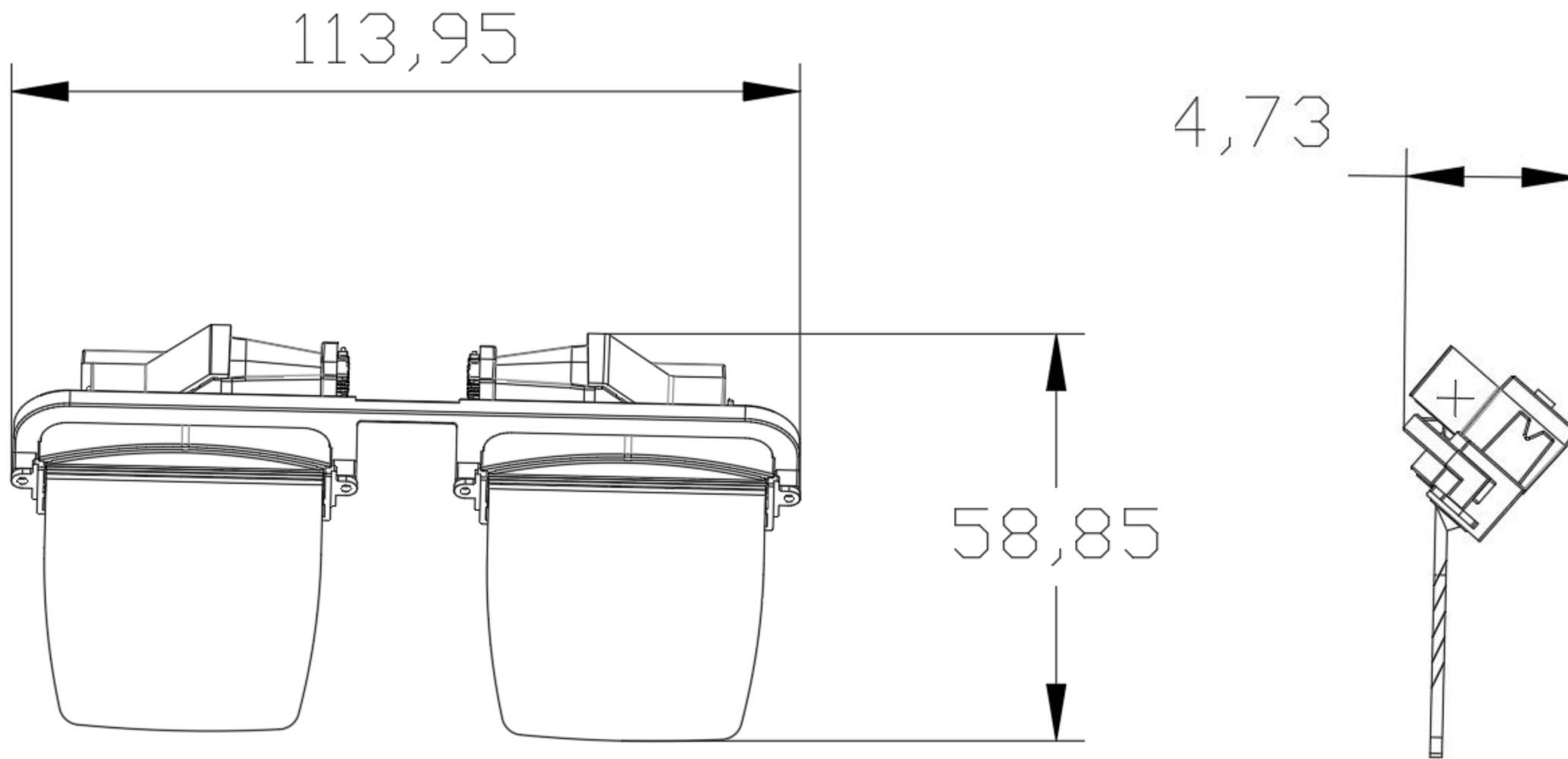

Hole Position Description

Recommended for use under conditions of -10°C to 70°C / 45% to 70% RH.

Service Life

- 1.The theoretical service life of the entire unit: Over 12,000 hours (operating condition: 10 mW/mm²).
- 2.Aging test of the entire unit (240 hours of continuous operation): 100% of the samples passed.

Extreme Environment Usage Conditions

Extreme High Temperature Operation: 70°C, 6 hours - The screen displays normally without any abnormal images or flickering. The driver board controls are functioning properly.

Extreme Low Temperature Operation: -20°C, 6 hours - The screen displays normally without any abnormal images or flickering. The driver board controls are functioning properly.

Extreme High Temperature Storage: 100°C - It functions normally after returning to room temperature without any abnormalities.

Extreme Low Temperature Storage: -40°C - It functions normally after returning to room temperature without any abnormalities.