

## TT-3 Turntable Manual

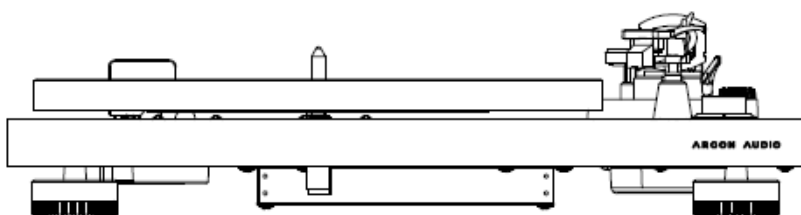
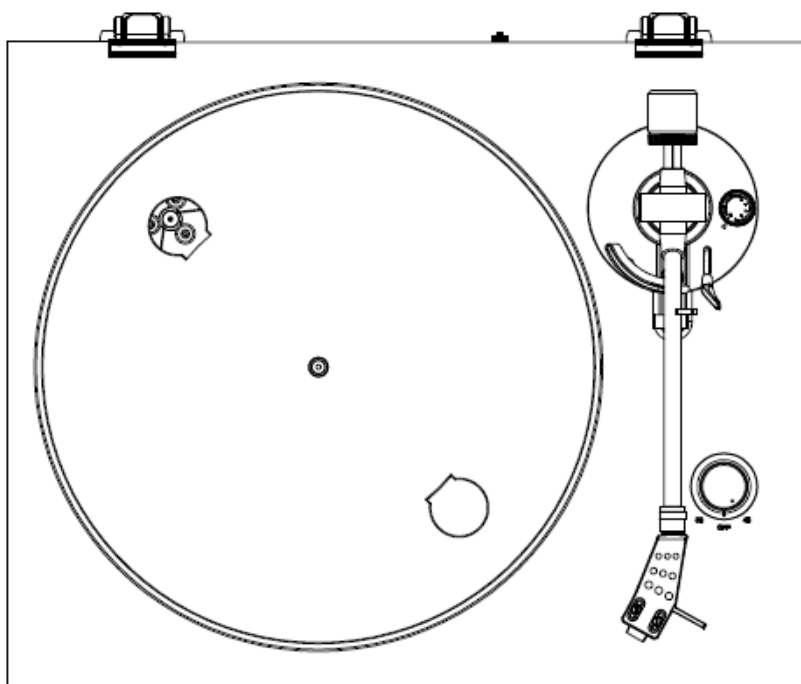

## Dear Customer

Argon Audio is a Danish audio specialist with almost 20 years of experience. At Argon Audio, we know that our customers work hard for their money and we respect that. As such, our mission has always been to bring our customers the most value for money we possibly could.

We produce our products and sell directly to you to ensure that you get the highest quality product for your money. None of Argon Audio's products go through the usual chain of distributors, meaning we can offer the best value for money products on the market today.

Argon Audio's products are sold throughout Europe in over 100 physical shops, but also directly to you from Argon Audio's own web shop.

**Congratulations with your TT-3, may it bring years of enjoyment.**



ARGON AUDIO

## Components, features and connections

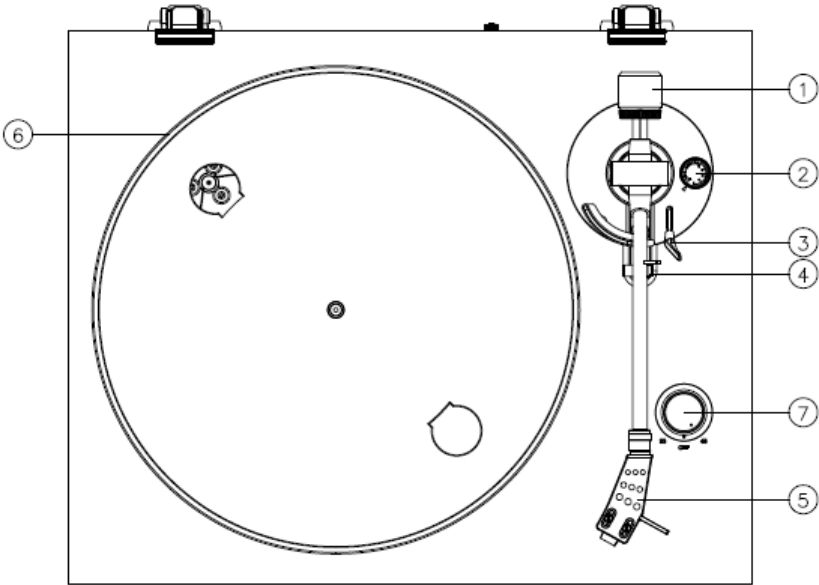

### 1. Counterweight

The counterweight is used for precise adjustment of the stylus pressure on the vinyl, to properly balance the tonearm.

### 2. Anti-Skating Control

Use this to set the anti-skating function of the tonearm.

### 3. Tonearm Lever

Use this lever to lower and raise the tonearm.

### 4. Tonearm Lock (arm rest)

Use this to lock the tonearm in place when not in use.

### 5. Headshell

This holds the stylus (“needle”) in place and provides protection by means of its removable stylus protection cap (not shown)

### 6. Platter:

Put the slip mat onto this platter before placing record disc.

## 7. 33/45 RPM Switch (33/off/45):

Select 33 or 45 rpm for playing a vinyl, switch to “OFF” to pause the playing. Switch to 33 or 45 again, to continue the playing from the pause point.

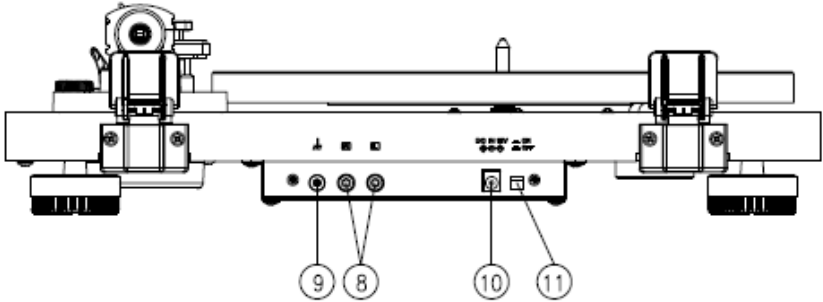

## 8. Signal Connectors

Plug in the RCA cable, and connect the cable to audio amplifier.

## 9. Ground Terminal

Connect a ground wire.

## 10. Power supply jack:

Plug-in DV12/0.5A switching adaptor for power supply.

## 11. Power Switch

## Turntable Platter and Belt Setup

1. Install the drive belt over the inner ring under the platter and make sure it won't fall off during the setup.

2. Place the platter through the turntable spindle, then rotate the platter until you see the drive motor pulley through the window at the top left corner.



3. Carefully grab the drive belt and put it around the slot of motor pulley.

4. Connect the power adapter to the turntable and power on the turntable. Set the speed to either 33 or 45. If the platter does not spin, try the steps listed above again.

5. Remember to place the rubber slip mat on the platter before playing records.

## Cartridge downforce adjustment

1. Gently push and turn the Counterweight onto the rear of the tonearm (with the scale facing toward the front of the turntable).
2. Remove the cartridge protection cap.
3. Lower the tonearm lift and position the cartridge in the space between tonearm rest and platter.
4. Carefully rotate the **Counterweight** until the tonearm balances out. The tonearm should return to the balanced position if it is moved up or down. This adjustment must be done carefully.
5. Once the tonearm is correctly balanced return it to its rest. Hold the **Counterweight** without moving it, and gently rotate the **Down force Scale** ring (the part with numbers on it) to 0. Check whether the arm still balances out.
6. Rotate the counterweight counter clockwise (seen from the front) to adjust the down force according to the cartridge manufacturer's recommendations.

**NOTE:** The recommended downforce for the factory fitted cartridge is 1.75g.

## Anti-skating adjustment

Turn the Anti-skating Control to the same value as the adjusted downforce. The recommended downforce for the factory fitted cartridge is 1.75g.

## Mains connection

An external switching power adaptor (DC12V 0.5A) is supplied with this turntable. Connect the turntable to a mains voltage of 110V/60Hz or 230V/50Hz.

## Amplifier connection

There is a RCA output on the rear panel of the turntable. Connect the RCA plug to this output, and then to the PHONO INPUT of your amplifier. Red plug into R channel input, White plug into L channel input. If your amplifier does not have an input suitable for phono cartridges, you will require a separate phono amplifier stage for MM or MC cartridges such as the Argon Audio PHONO1, which can then be connected between the record player and a free line level input of the amplifier. The ground wire of the tonearm lead should be connected to the earth terminal on your amplifier (if provided).

## Playing a record

- 1) Place the record on the turntable. If it is a 45 rpm, you need to place the adaptor on the record spindle.
- 2) Switch on the power.
- 3) Pull up the arm lifter, and then release the arm lock clip.
- 4) Place the cartridge vertically over the first track of the record.
- 5) Rotate the RPM knob to the speed you want to play, which will cause the platter to start turning.
- 6) Lower the arm lifter. The stylus will touch the record and start playing music.
- 7) When the record is done, lift the tone arm up, lead it back to the arm rest and lock it.
- 8) To pause the playing, lift the tone arm by pull up the arm lifter, and then turn the speed knob to "OFF".

## Replacing the cartridge

- 1) Unscrew the headshell from the tonearm
- 2) Unscrew the cartridge from the headshell, and disconnect the 4 wires to take off the cartridge as below:
  - White wire: Left channel, Positive pole
  - Blue: Left channel, Negative pole
  - Red: Right channel, Positive pole
  - Green: Left channel, Negative pole
- 3) Tightly screw the new cartridge to the headshell, and connect the wires correctly using the information above.
- 4) Remember to adjust the counter weight stylus pressure and anti-skate value according to the new cartridge specifications.
- 5) The full sound quality of the Argon Audio TT-3 can only be achieved if the cartridge is correctly adjusted. If you are not well acquainted with the adjustment of cartridges you are advised to call upon the willing help of your Argon Audio dealer to accomplish this task for you.

## Specifications

These specifications are based on the factory mounted cartridge of Ortofon OM5E

Drive Method	Belt drive
Motor	DC motor
Speed	33-1/3 rpm, 45 rpm
Rotation Speed Variation	±2%
Wow And Flutter	0.2%
Platter	Aluminum die-cast (Diameter 30 cm)
Output Level	4 mV
Signal To Noise Ratio	67 dB or higher (A-weighted, 20 kHz, LPF)
Tonearm	Static balance straight tonearm
Effective Arm Length	223.5 mm
Overhang	19 mm
Acceptable Cartridge Weight	15.5-19 g (including headshell)
Cartridge Type	MM type
Output Voltage	4 mV (at 1 kHz, 5 cm / sec)
Stylus Pressure	1.75 ± 0.25 g
Cartridge Weight	5.0 g
Headshell Weight	10 g (including screws, nuts and wires)
Output Terminal	RCA: 1 (PHONO)
Power Consumption	1.5 W
Dimension (W×H×D)	420mm * 121mm * 355mm
Weight	5 kg.